

# nature LOO<sup>®</sup>

## Classic 850 Installation & Maintenance Manual

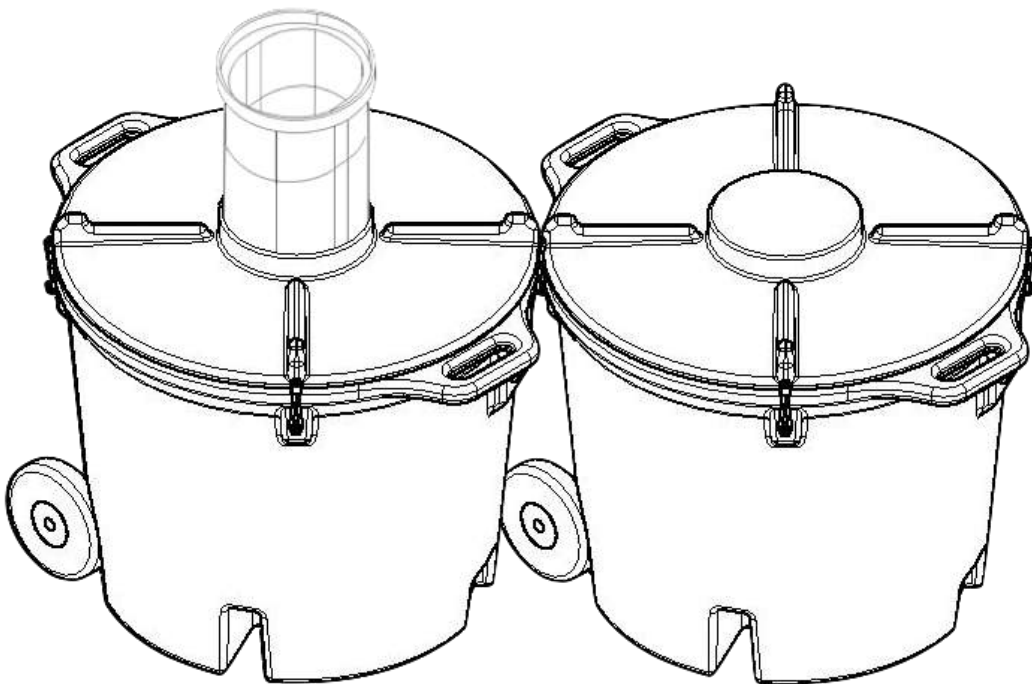

- Thank you for purchasing the Classic 850. Please read this manual carefully before installation.
- “Nature Loo” is a brand of Ecoflo Wastewater Management Pty Ltd.
- Visit our website at [www.ecoflo.com.au](http://www.ecoflo.com.au)

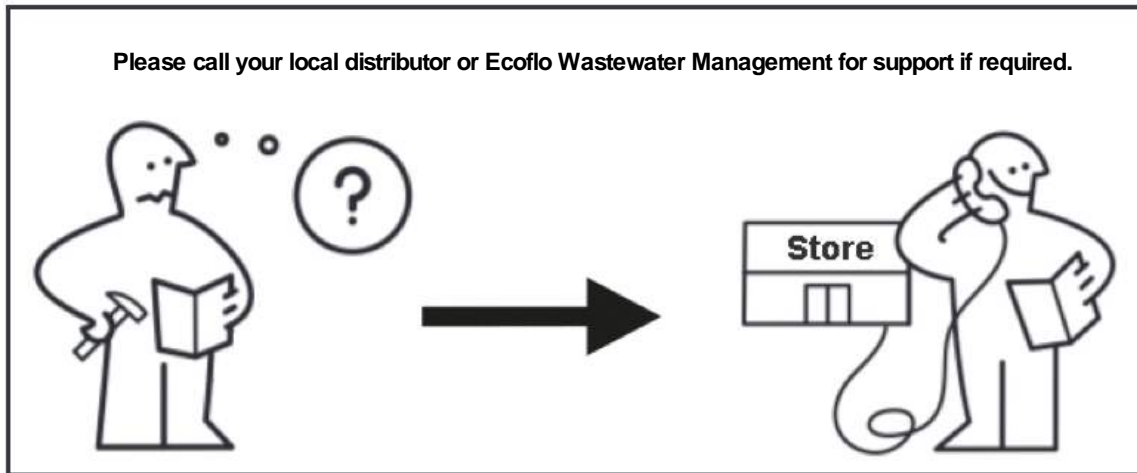

## Ecoflo Wastewater Management Pty Ltd

6 Hurricane St,  
Banyo QLD 4014  
[www.ecoflo.com.au](http://www.ecoflo.com.au)  
[www.natureloo.com.au](http://www.natureloo.com.au)

Phone: 1300 138 182  
Phone: 07 3889 6144  
Email: [info@ecoflo.com.au](mailto:info@ecoflo.com.au)



**Proudly Designed and Assembled in Australia  
by Ecoflo Wastewater Management**



# Table of Content

<b>WHAT'S IN THE BOX?</b> .....	<b>3</b>
<b>CLASSIC 850 SCHEMATICS</b> .....	<b>4</b>
<b>INSTALLATION</b> .....	<b>5</b>
<i>Step 1: Positioning the Pedestal Diagram</i> .....	5
<i>Step 2: Positioning the Waste Chute</i> .....	6
<i>Step 3: Installing the Waste Chute</i> .....	7
<i>Step 4: Installing the Toilet Pedestal - refer to Pedestal Installation Manual</i> .....	8
<i>Step 5: Installing the Wheels to the Composting Chamber</i> .....	8
<i>Step 6: Installing the Compost Chamber</i> .....	9
<i>Step 7: Connecting the Vent Pipe and Fan to the 'In-service' Chamber</i> .....	10
<b>POWERING YOUR FAN</b> .....	<b>12</b>
<i>Mains Power</i> .....	12
<i>Solar Power</i> .....	12
<b>EXCESS LIQUID ABSORPTION TRENCH</b> .....	<b>13</b>
<b>COMPOSTING ACCELERATORS</b> .....	<b>14</b>
<b>CARE &amp; MAINTENANCE</b> .....	<b>15</b>
<b>ROTATION OF CHAMBERS</b> .....	<b>16</b>
<b>TROUBLE SHOOTING</b> .....	<b>17</b>
<b>PRODUCT &amp; COMPONENT WARRANTY</b> .....	<b>19</b>
<b>MAINTENANCE SCHEDULE</b> .....	<b>20</b>
<b>APPENDIX 1</b> .....	<b>21</b>





# CLASSIC 850 SCHEMATICS

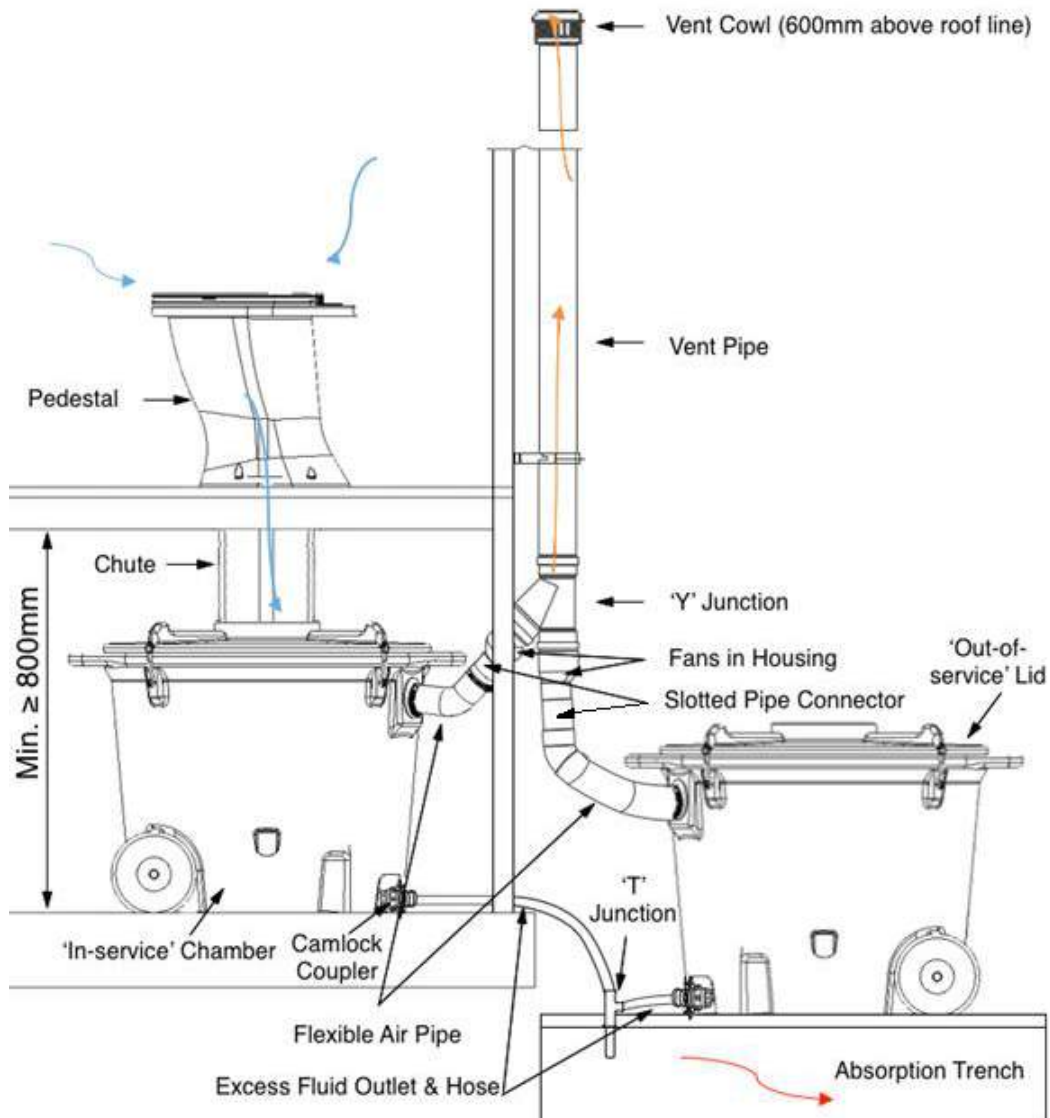

Ensure there is a minimum clearance of **800mm** beneath the toilet room floor for the Nature Loo composting chambers.

***If you are planning to excavate an area under the house for the compost chambers, please ensure the area is well-drained and any retaining walls are built to the satisfaction of the local authority.***



# INSTALLATION

## Step 1: Positioning the Pedestal Diagram

Locate the approximate area where you want the pedestal to go before cutting the hole.

The usual position for pedestals is centred between side walls.

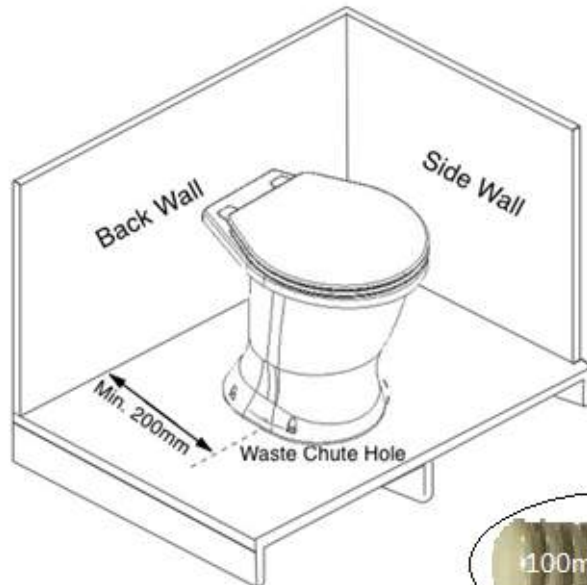

Options:

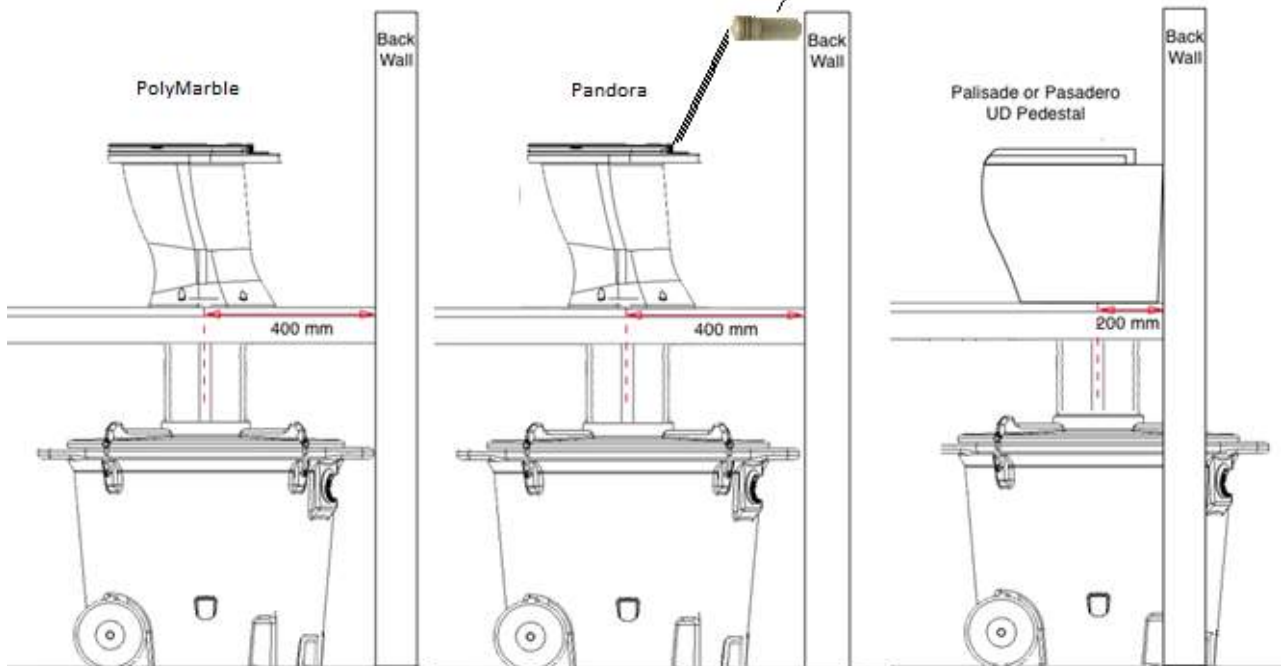

Note : If you require the 'In-service' chamber to be fully under cover, the distance between the back wall to the centre of the waste chute should be **400mm**.

At 400mm from the wall, the Seat & Seat Cover will be unsupported when in open. Ideally a support of approximately 80-100mm long, mounted on the wall will suffice. \*See suggestion above.

## Step 2: Positioning the Waste Chute



Based on the Classic 850 Schematic, the pedestal is connected to the composting chamber, below the floor, by the waste chute. A **240mm hole** must be cut in the toilet room floor to accommodate the waste chute.

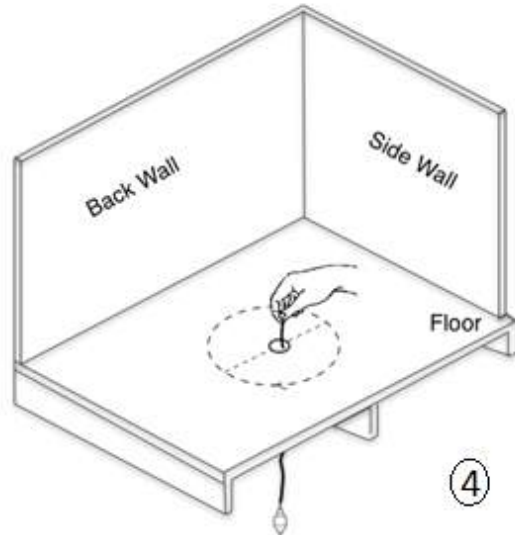
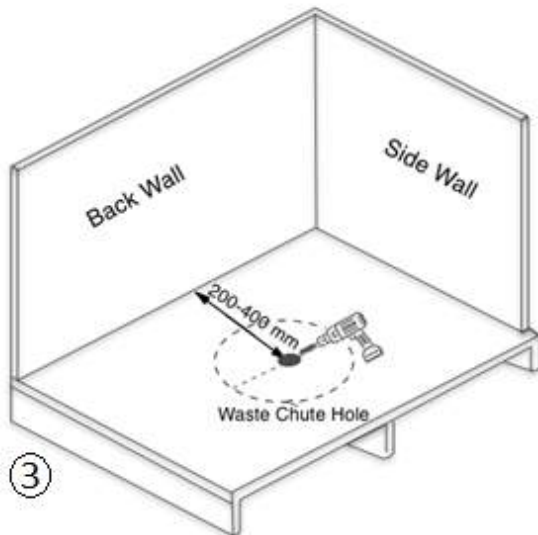
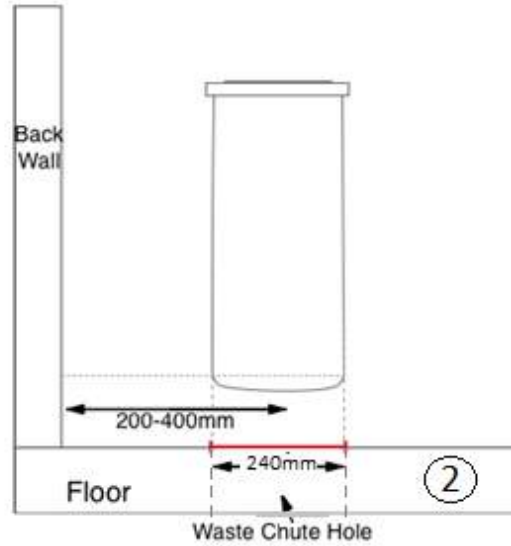
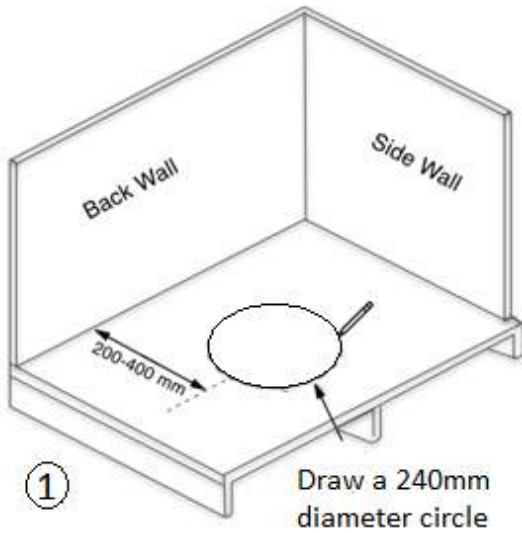

Go to the under-floor area and look for the hole you have drilled, and the dangling string.

Check to see if there is a floor joist, water pipe or electrical wiring under the area you are going to cut.

### Example:

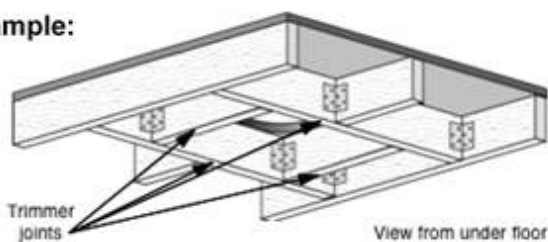

NOTE: If there is a joist in the way, either reposition the waste hole OR install trimmer joists to each end of the cut joist, and fix all connections with galvanised framing anchors with 4 nails each leg. (see diagram)



### Step 3: Installing the Waste Chute

First ensure the pad or ground level on which the 'In-service' chamber will reside is at its final level beneath the toilet room.

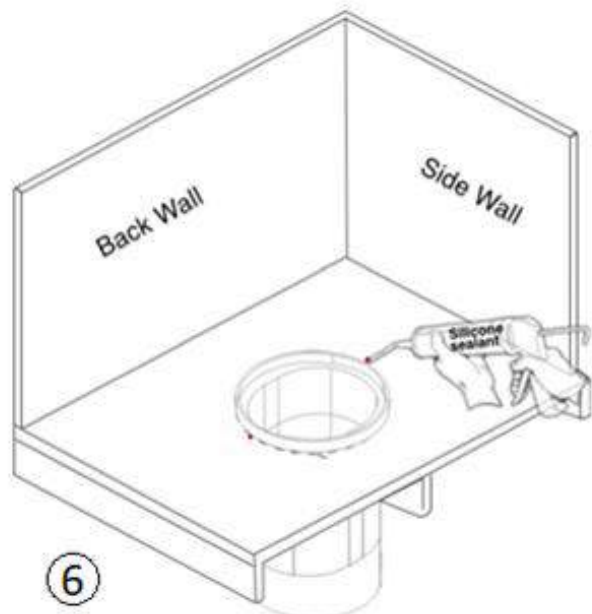
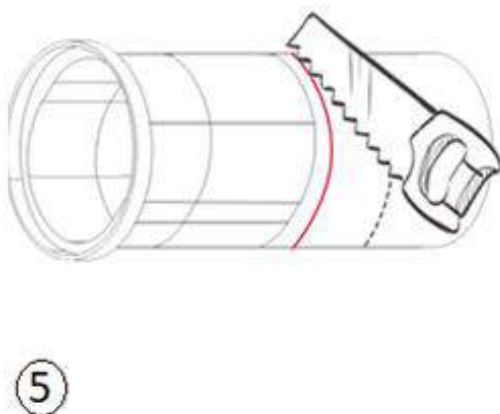
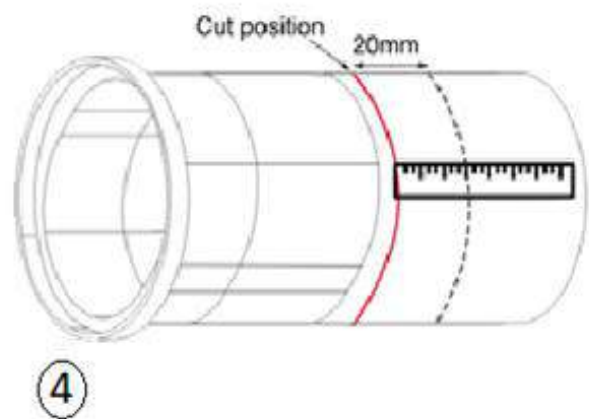
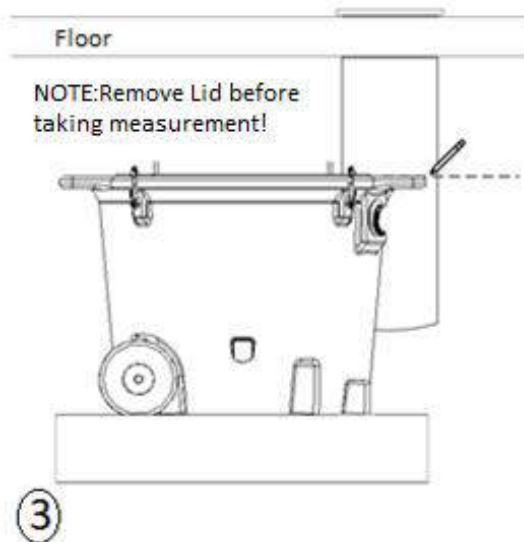
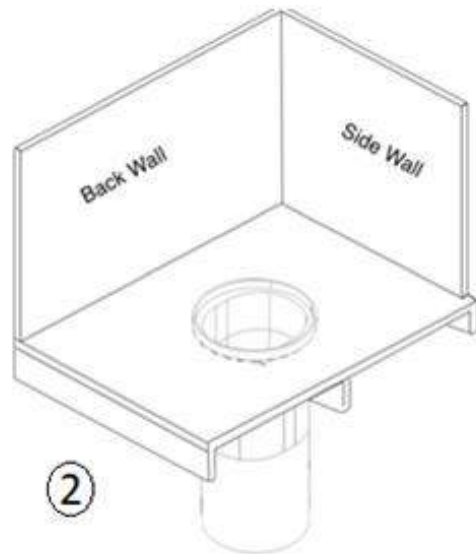
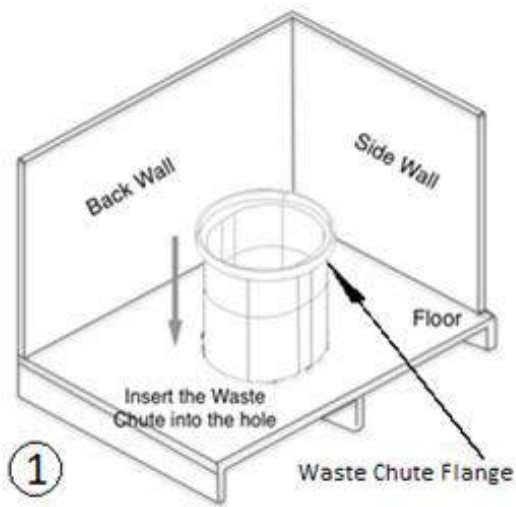



## Extra Length Required for Under-floor Areas

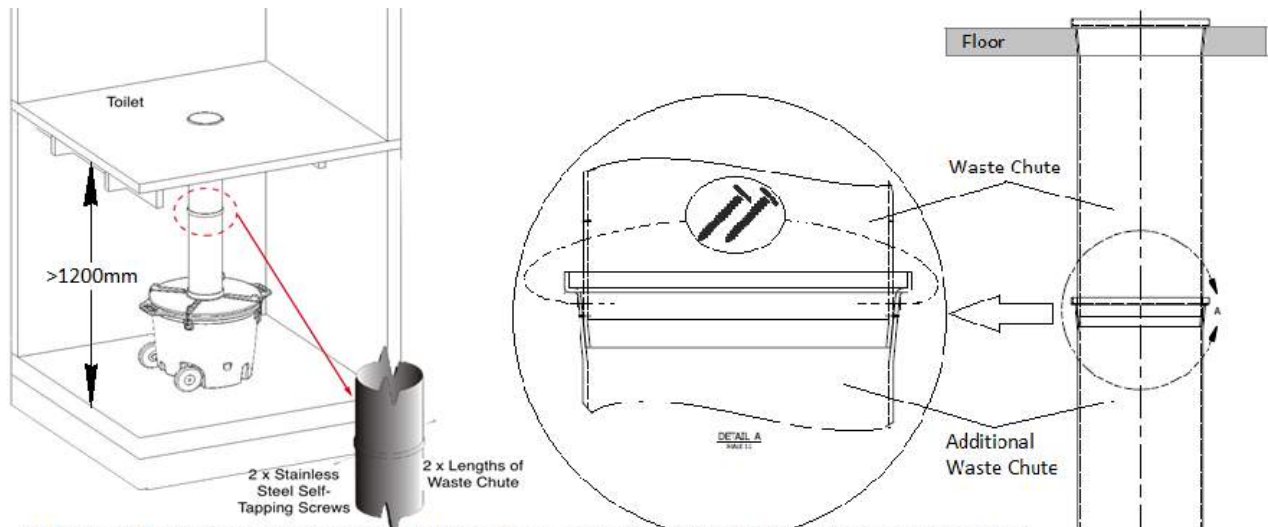

If the Underfloor height exceeds 1200mm (floor-to-floor), you will require additional lengths of chute, fixed together with small Stainless steel self-tapping screws below the flange of the Additional Waste Chute. As the Chute joints are Tapered, the top Waste Chute must be inserted through the toilet room floor first with Additional Waste Chutes added from below.

## Step 4: Installing the Toilet Pedestal (refer to Pedestal Installation Manual)

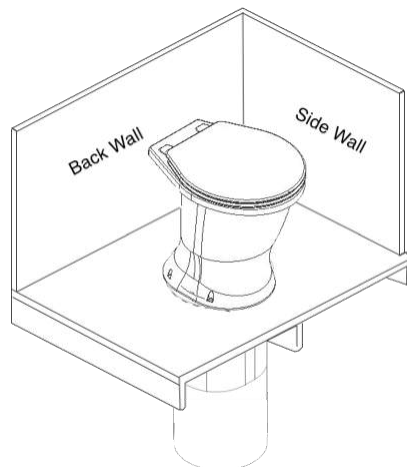

## Step 5: Installing the Wheels to the Composting Chamber

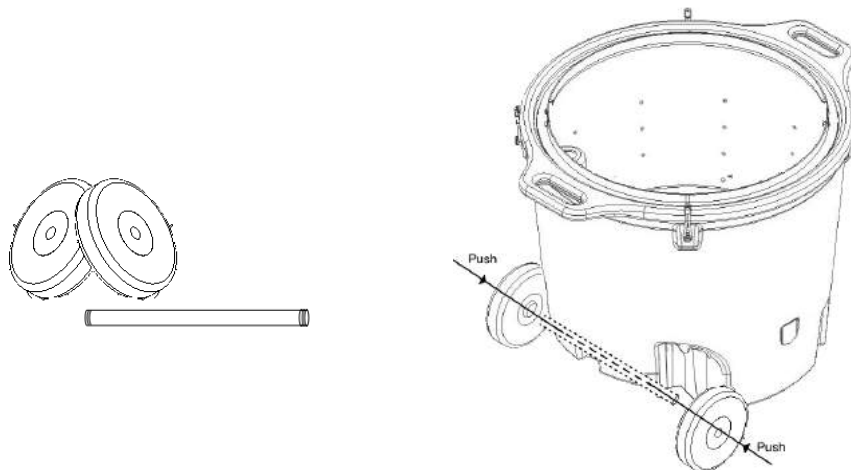

## Step 6: Installing the Compost Chamber

Slide the 'In-service' compost chamber lid (with Pre-Cut Hole) up onto the waste chute from underneath (A brush seal is supplied & fitted to the 'In-service' lid and acts as a seal to prevent any odour emitting from the chamber.)

1. Add 50mm Bulking Agent to the Chamber



2. Use the x4 M6x25 Bolts, Nuts & Washers to connect the Compost Mixer to the Mixer Ring.

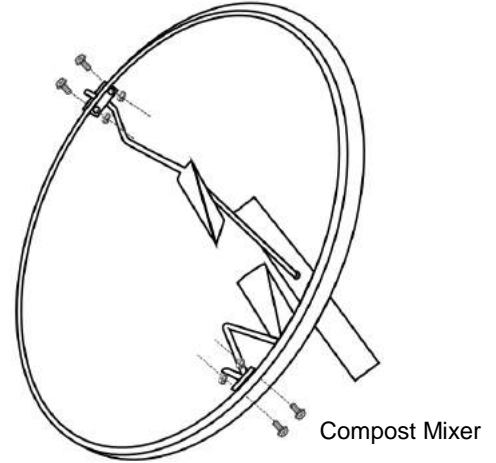

3. Put the Compost Mixer into the Chamber.

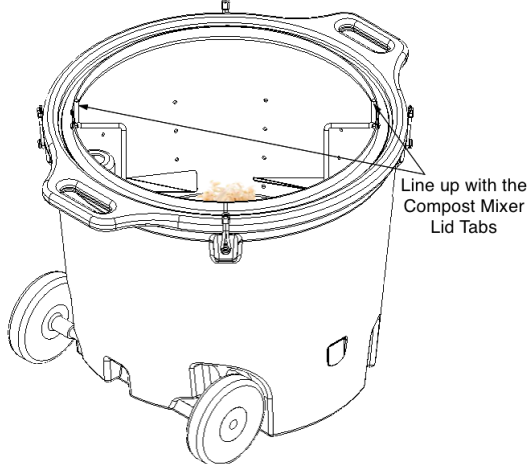

4. Close the Bunji Loops

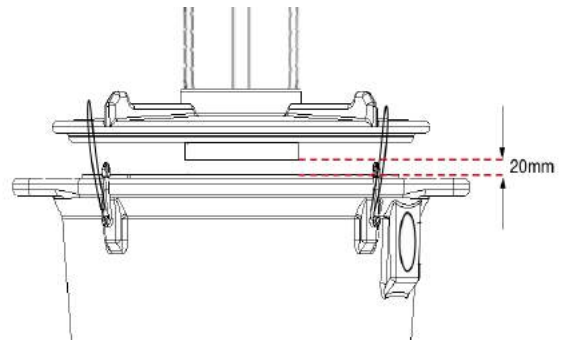

### OPTIONAL

To assist composting in colder climates, we recommend the purchase of an optional heater pad which is permanently fixed inside the chamber. The Pad will be factory installed. The Heater Pad runs on 12 Volt Power. (Refer to the supplementary manual.)

Note : The Heater Pad should not be submerged – Check your 'Excess Fluid Outlet' for blockages regularly



## Step 7: Connecting the Vent Pipe and Fan to the 'In-service' Chamber

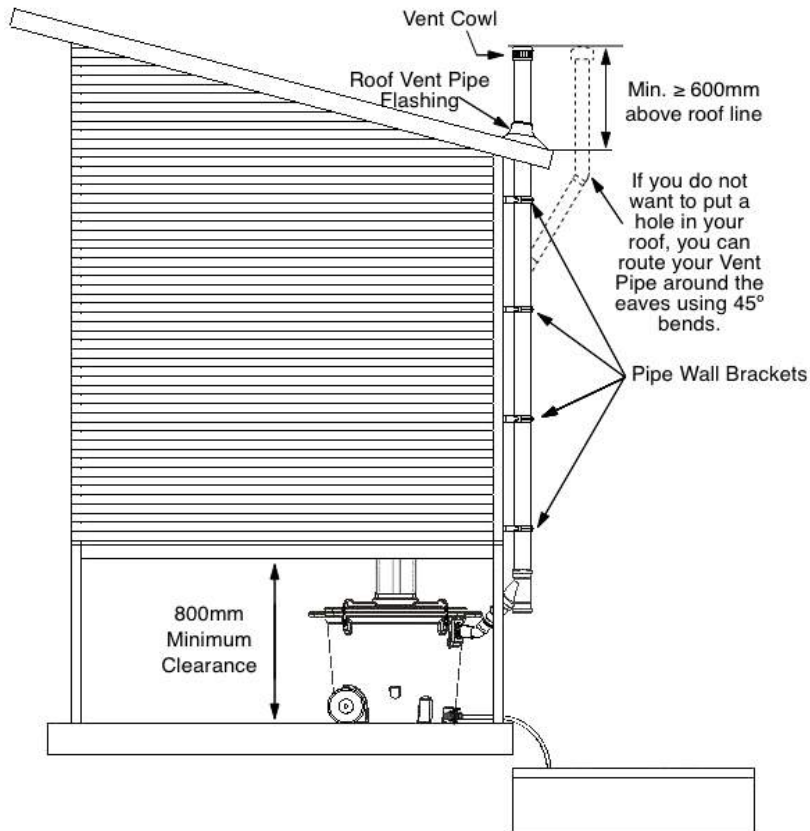

The fan runs 24 hours a day to continuously circulate air through the compost heap. Air is drawn down the toilet pedestal through the compost chamber and out the vent pipe.

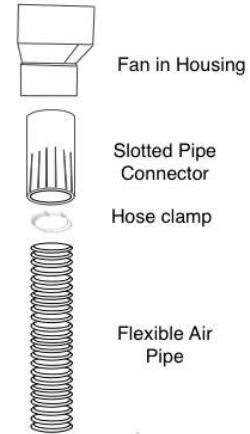

## Fan & Vent Cap Installation Details

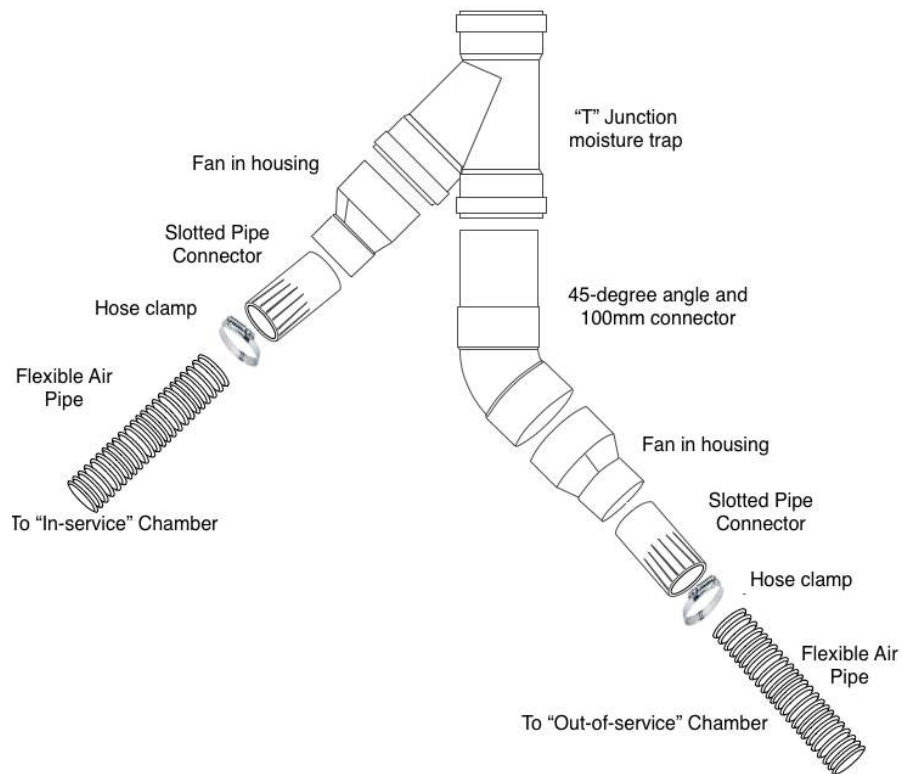

**Ensure the fan is kept out of the weather to increase its longevity. Do not glue the fan housing to the 'Y' piece so the fan can be replaced, if required.**



**Connect the Flexible Air Hoses to the Chambers by:**

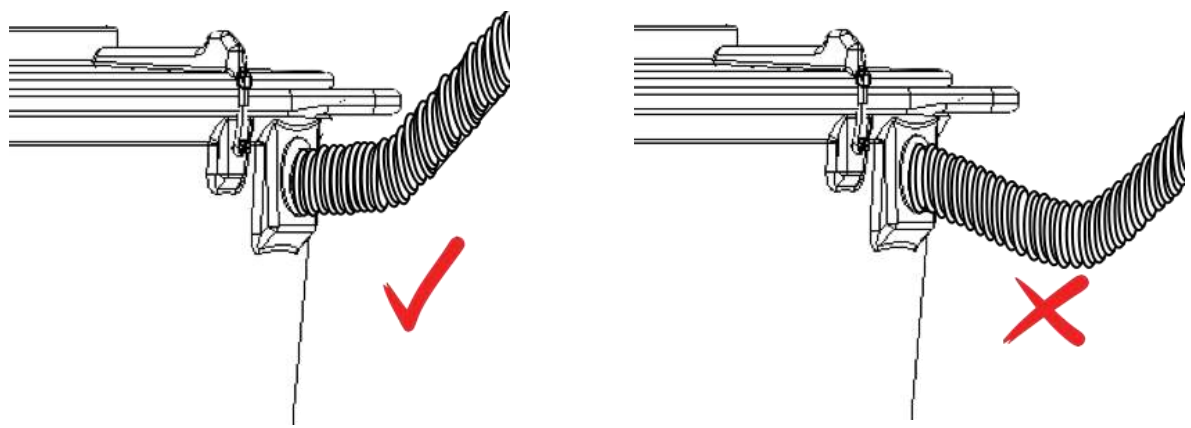
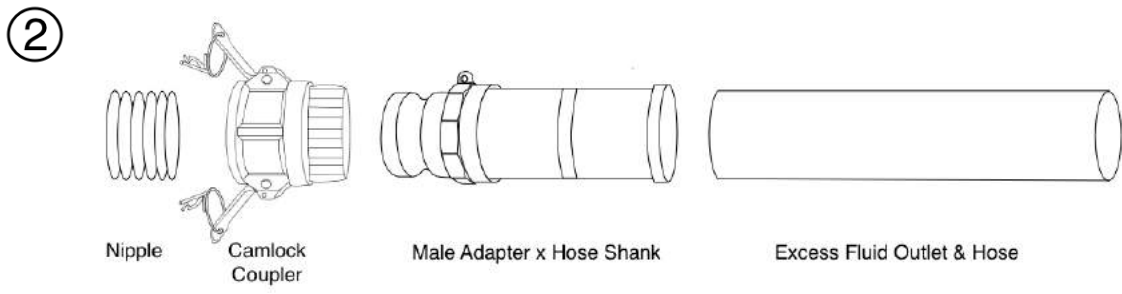
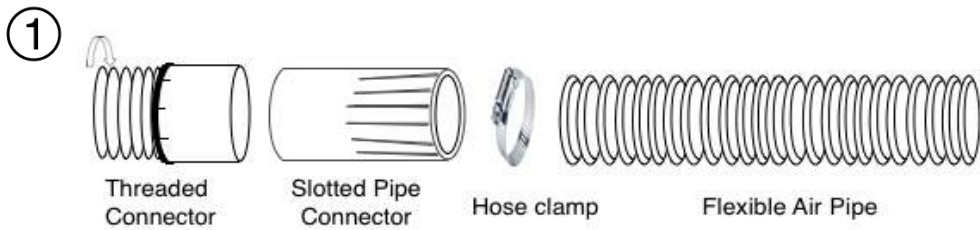
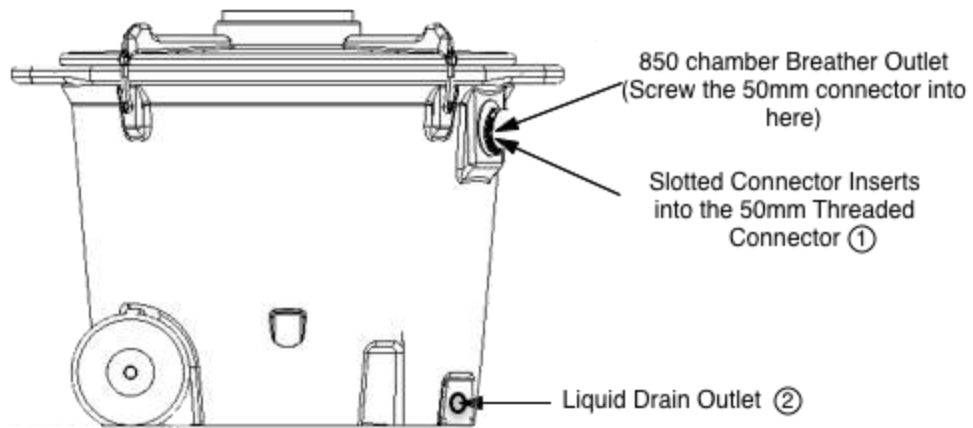

# POWERING YOUR FAN

(Please Read the **Fan Warranty Information**; on the following page, **Before Connecting** the 12 Volt Fans to Power)



## Mains Power

A 240/12 volt regulated transformer is included to run the fan from mains power. Connect the fans to the transformer as follows:

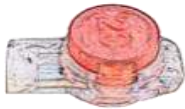

1. Do not depress the crimp connector before you are ready to secure the wire ends together.
2. NOTE : This is a SINGLE-USE item! Once triggered it cannot be reused.

**NOTE :** Allow a **minimum of 5mm** of exposed wire inserted into crimp connectors.



3. Insert the red (positive) wire from both fans into any hole in the first crimp connector.
4. Insert the wire from the transformer with the white line (positive) or the black extension cable into another hole within this first crimp connector.
5. Press down firmly until the top clicks down into place and is depressed so it cannot be removed.
6. Repeat the above instructions with the remaining crimp connectors (matching the blue (negative) wire with the solid black transformer wire or the red wire extension then the transformer cable.

*“Ensure the transformer is in a cool, dry and airy location.”*

We recommend a spare fan is kept on hand at all times, particularly after a year of use.

Go to [Ecoflo Online Store](#) or call 1300 138 182 for replacement or spare fans.



## Solar Power – refer to Solar Panel Installation Manual



### **Fan Warranty Information**

With proper installation and care the fans will provide several years of reliable service. **However, experience has shown, improper installation may result in the failure or greatly reduced life of this product.**

Powering the fans by unregulated power sources such as some solar-based systems or other sources in excess of a regulated 12 volts will reduce the life of these fans and may result in immediate failure. **If you are considering connection to a source other than a transformer or solar panel as supplied by Ecoflo, you should read the warranty conditions below.**

#### Limited warranty conditions – 12-volt fan:

The 12-volt fans supplied with your Classic 850 come with a three-month manufacturer's warranty. **Ecoflo triples the term of this warranty in addition to the manufacturer to 12 months from date of purchase and will replace any fan that fails during the warranty period but only under the following conditions:**

- The fan must be connected and powered by either a 12-volt transformer or solar panel supplied or otherwise recommended by Ecoflo. Connecting your fan directly to a power source other than one supplied or specified by us may result in immediate damage to the fan and will void all warranties.
- The fan must be installed as specified in the owner's manual supplied with the toilet and must not be modified or altered in any way.
- In the event of failure during the warranty period, the faulty fan must be returned to Ecoflo who will ship a replacement by regular mail service on the next business day providing the above conditions have been met.

## **EXCESS LIQUID ABSORPTION TRENCH**

***An Absorption Trench Kit is available – Please see Appendix 1.***

*Alternatively; If your council allows, you may wish to construct your own Absorption Trench. The Liquid Drain Hose should run into either a length of 50mm PVC pipe; drilled to allow liquid to escape, OR a length of slotted Ag pipe buried in the absorption trench as shown in the diagram. Both chambers should be connected.*

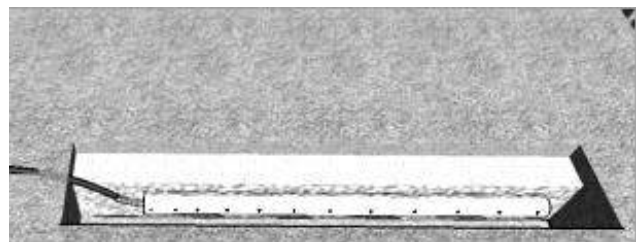
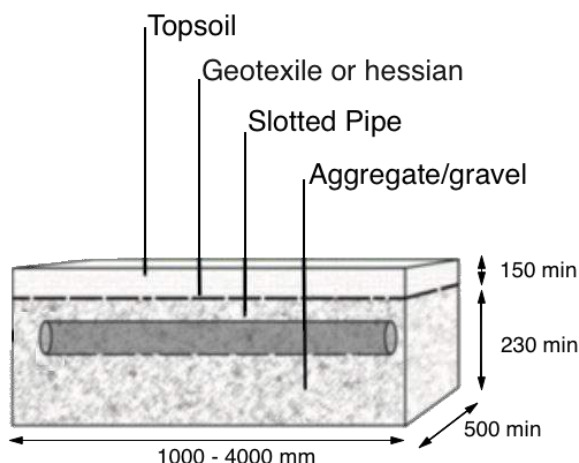

## COMPOSTING ACCELERATORS



Whilst Nature Loo users report successful composting without the use of any additives, we strongly recommend the use of the following in order to optimise composting, particularly when the toilet is in permanent use by more than two people.

- **Bulking Agent**

Should be added on a regular basis, preferably a handful after each solid use. Alternatively, if this is not possible add the equivalent of this on a daily or weekly basis. The bulking agent can be added through the pedestal.



Refer to our website for suitable bulking agents.



***We Do Not recommend the use of :***

- ***sawdust as it creates an anaerobic condition within the chamber.***
- ***Cypress, cedar or eucalypt wood shavings due to their antimicrobial properties.***

- **Nature Flush Enzymes**

A 125ml bottle of enzyme concentrate is supplied with the toilet. Please refer to the label for instructions and spray into the waste chute. A spray flask is provided. Any staining of the pedestal can also be removed with the spray.



- **Nature Quick Microbes**

Should be used each time a chamber is changed to kick start the process in the new chamber.



**Contact [Ecoflo](#) for further supplies when required.**

- **Compost Mixer**

Turn the Compost Mixer **Anti Clockwise** 3-5 times a week to aerate the pile and knock down the 'cone'.



# CARE & MAINTENANCE

## Daily or Weekly

- Clean restroom & toilet fixtures using only biodegradable cleaners.
- Add 1 cup of bulking agent to toilet after every solid use.
- Turn the Compost Mixer Anti Clockwise 3-5 times a week or possibly more often once the chamber becomes full.



Check Ecoflo Online Store for [Consumables](#).

## Monthly

- Inspect the 'In-service' chamber, depends on usage, prepare another 'In-service' chamber for use once the chamber becomes full (refer to **Rotation of Chambers**).
- Check vent pipe & remove any foreign matter.
- Check the fan is operating.





## ROTATION OF CHAMBERS

- **Your first rotation of the chambers**

 <b>CAUTION</b>	<i>It is important to observe safety procedures when dealing with fresh human waste. Please ensure you wear protective clothing (gloves and old clothes). Do not attempt to move the chambers on your own.</i>
--	--

The Nature Loo composting toilet chambers will need to be changed on a regular basis. A sufficient number of chambers must be purchased to allow the 'Out-of-service' chamber a **minimum 5 months**; depending on climate, from the time they are disconnected from the waste chute.

1. Prepare a new 'In-service' chamber for use (refer to **Step 6: Installing the Compost Chamber**).
2. Pour a small bucket of bulking agent (clean mulch) down the pedestal to cover up the waste pile.

- **Extra Chamber/s**

An 'Out of Service' chamber should be put in a warm sheltered position with the Air Intake Cap attached to the lid and one to the base. (Image below)

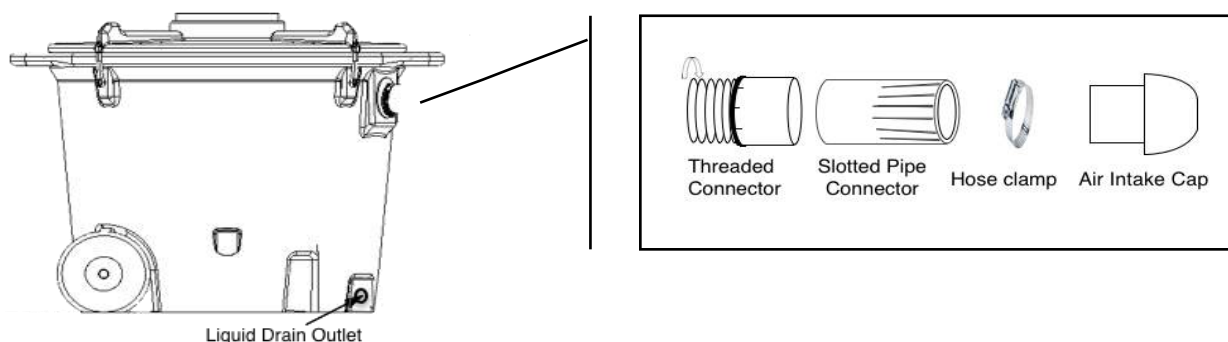

- **Removal of Compost**

The pile should have reduced in size to about 20% of its original size and contain a maximum of 75% moisture. This 'humus' must then be disposed of as per the local health department regulations. This normally means digging the humus into the soil and covering with at least 100mm of soil.

- **Returning a Chamber to Service**

1. Ensure all hose and vent connections are clear.
2. Prepare the 'In-service' chamber for use (refer to **Step 6: Installing the Compost Chamber**).

*If the 'Out-of-service' chamber is to be placed away from the house, you will need to dig a small second trench (20 x 20 x 20cms) to allow residual liquid to exit the chamber. Connect the second liquid drain hose from the chamber to the trench and turn the valve to the open position.*



# TROUBLE SHOOTING

Please read this section before using your toilet.



Find more Trouble Shooting and FAQ information online at [ecoflo.com.au/FAQ](http://ecoflo.com.au/FAQ), or call us on 1300 138 182.

Nature Loo toilets have proven themselves to be one of the easiest systems to manage. However, being a natural process, reliant on a number of factors beyond our control, it can occasionally need some help to maintain an appropriate balance.

## **The 'In-service' chamber is filling too quickly:**

This may be caused by a number of factors:

- 1) **The temperature is too low** for effective composting.  
With the Classic 850 you can improve this problem by wrapping the chamber in insulating material (including the base), OR use a chamber with a heating element option (page 9).
- 2) **Insufficient air flow.** ' This can be caused by a broken fan or the chamber being too full. Check the fan is operating and the level of the pile is not too high. This problem could also be caused by a blocked insect screen in the cowl.
- 3) **The pile being too wet.**  
This could be the result of the outlet of the liquid chamber being blocked and causing the upper chamber to flood. (This would also cause the fan to malfunction). Check the drain hose is not blocked and flush with a hose if necessary. You may need to change chambers if the blockage is in the chamber and thoroughly flush out the contents of the liquid chamber.
- 4) **Antibiotics and disinfectants will slow down or stop the process.** Restart the composting by reintroducing microorganisms. In many of these situations Nature Flush Enzymes will help solve inefficient composting by breaking down the solids and thereby speeding up decomposition.

## **The 'Out-of-service' chamber is composting too slowly:**

This may happen due to one or more of the problems described above. At this point the most effective course of action is to aerate the pile by turning it over with the Compost Mixer. You could also add 500ml of Nature Flush Enzymes from a domestic spray bottle as you turn the material and add a quantity of Nature Quick Microbes.

You should consider locating the chamber where it has a greater exposure to direct sun light. However, if you find the pile is drying out too quickly put the chamber in a shadier position.

If you find none of the above measures are effective, it means the local climatic conditions are less than ideal. This can happen in cold or humid conditions and you will need to purchase an additional chamber in order to provide an extended composting period.

If you need to change your 'In-service' chamber and the 'Out-of-service' chamber is not yet composted dispose of the waste as normal and order a new chamber from [Ecoflo](http://Ecoflo).

If the 'half-life' is too great, we suggest ordering a chamber with a Heating Pad for the winter months. Please consider the power requirements (12volt 100Watt 8.5Amps) when using the Heating Pad option off-grid.

## **The odour from the 'Out-of-service' chamber is unpleasant:**

If the 'Out-of-service' chamber is not connected to the vent pipe it may smell immediately after it has been taken 'Out-of-service'. Odours can be greatly reduced or eliminated by *covering the top of the pile with straw or dry grass clippings*. You may wish to do this before disconnecting the chamber.



**The odour from the 'In-service' chamber is unpleasant:**

If this is not caused by a *failed Fan* or *associated Screen* or a blockage in the *Vent Pipe* or *Liquid Drain Hose* or *Fitting*. Please see the "**'In-service' chamber is filling too quickly**" section for how to resolve this problem.

**The power has failed resulting in toilet room odours:**

Cover the pedestal with cling film until the power is restored. To avoid a recurrence of this problem, have us send you our uninterrupted power source (UPS). The UPS will cut in with power from a 7-amp hour battery whenever the mains power goes down.

Helpful Hints from our customers :

- Paint the Vent Stack black to produce an upward air flow.
- Add a wind assisted turbo vent to the Vent Stack.



**Please make sure you use protective clothing and gloves  
when handling any human waste.**



# PRODUCT & COMPONENT WARRANTY

Ecoflo will furnish new parts to a customer whose toilet fails within the allotted warranty period for the particular component, provided that our inspection shows such failure is due to defective material or workmanship. Any part supplied is warranted for the balance of the original warranty period. The warranty period for a part begins from the date the original product was dispatched (plus 10 working days for transportation).

## **Warranty Period:**

Any electrical component including solar	1 year
Any rotomoulded component	10 years
Any fibreglass/polymarble component	3/5 years
Toilet seats	1 year
Any other component	1 year

## **This warranty does not cover:**

- Damage resulting from neglect, abuse, accident or alteration; or damage caused by fire, flood, acts of god or other causality.
- Damage resulting from failure of the purchaser to follow normal installation and operating procedures outlined in the manual or in any other printed instructions supplied with the system.
- Labour and service charges incurred in the removal and replacement of any parts found defective under this warranty.

Items subject to a dispute, where photographic evidence is inconclusive, must be sent prepaid to Ecoflo. The cost will be reimbursed by Ecoflo should the claim be found valid.

**In addition to the above,** Ecoflo will only replace a fan that fails during the warranty period under the following conditions:

- The fan has only ever been connected and powered by either a 12 volt transformer plugged into mains power or a solar system supplied by Ecoflo. Connecting your fan directly to a power source other than one supplied or specified by Ecoflo may result in damage to the fan and void the warranty.
- The fan and transformer must not be modified/altered in any way.
- The faulty fan is returned to Ecoflo for inspection, if required.

Providing the above conditions have been met replacement fans are shipped the same or following day free of charge by regular post.



# MAINTENANCE SCHEDULE

*Please place this maintenance schedule close to your 'In-service' Chamber and complete the table as you rotate your chambers.*

**Model:** Nature Loo Classic 850

**Date First Put into Service:** \_\_\_\_/\_\_\_\_/\_\_\_\_

*The 'Out-of-service' chamber must compost for a minimum of 5 months from the date it was first rotated 'Out-of-service'.*

**Date chambers were last rotated:**



***Wear protective clothing including gloves and eyewear when servicing, rotating or emptying chambers.***

# APPENDIX 1

## INSTALLING EVERTRENCH LINERS FOR SULLAGE - WASTE WATER DISPOSAL

AS/NZS 1547:2012 provides basic information for the design and construction of many on-site waste-water disposal systems. This manual also includes information offered by EVERHARD, which has found to be of value. EVERTRENCH injection moulded polypropylene Arched Liners is used for "Conventional" evapotranspiration-seepage (ETS) and evapotranspiration-adsorption (ETA) layouts described in the standard.

**All waste-water poses a health hazard. All layouts for Wastewater disposal land application areas must be designed by competent and authorised persons, taking the following factors into account:**

- The Volume of wastewater, based on household size and appliances.
- The rate of absorption of the surrounding soil.
- Limits imposed by site conditions, such as slope, contours, prevailing wind and permanent shade etc..

**Before beginning design and construction of wastewater disposal system, check State and local authorities for requirements for your area. Conventional trenches and beds may not be permitted.**

Plants should be selected from approved lists for disposal areas, to minimise root intrusion problems.

**Method 1: Trenches:** These are generally used in sites where soil is permeable enough to allow projected amounts of wastewater to drain freely into the trench floor. Trench should be wide enough for the EVERTRENCH Liner and deep enough for the selected Liner to be not less than 150mm below the surface.

1. Excavate the trench along a level site contour, with the floor not less than 50mm deeper than the invert of the pipe from the Septic Tank or sullage distributor, with at least 150mm cover over the top of the Liner.
2. The trench floor should be level, evenly raked, and have no low spots which would allow "ponding".
3. Allow at least 75mm overlap for each length of EVERTRENCH Liner.
4. Fit Three Brace Bars into each Standard EVERTRENCH Liner, the first 220mm from the inlet end, then equally spaced along the excavation.
5. Cut the pipe entry hole in one Trench Liner End Cap, and fit the Caps to the Liner. Connect piping from the Septic Tank or Sullage Distributor.
6. Lay geotextile fabric over the full length of Trench Liner.
7. Place a 150mm layer of 20 - 45mm aggregate material along both sides of the Trench Liner, and at both ends to secure the End Caps. Rake level.
8. Cover the installation with a layer of topsoil, less permeable than the parent soil to help prevent stormwater entering the trench. Leave a slight mound for natural compaction. Turf may be laid over the trench area.

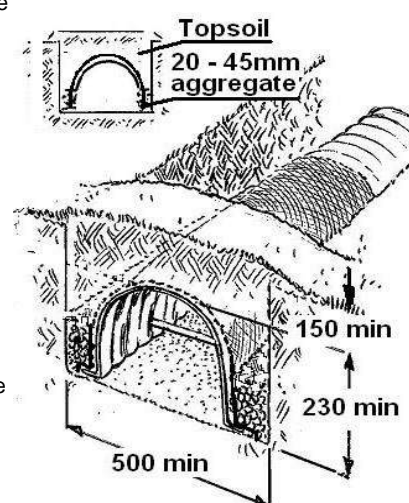

**DO NOT COMPACT the trench area or expose it to traffic.**

**Method 2: Beds:** These are generally used where soil conditions do not allow the planned volume of wastewater to drain freely from normal trench systems. Evapotranspiration beds encourage treated wastewater to be taken up by plant roots over a wide area, as well as draining into the soil, offering additional safety for seepage systems. Beds consist of standard width trenches, deeper than normal, with the area above the selected Trench Liner of much greater width, and filled with material allowing easier penetration of roots and transfer of moisture. Bed designs may vary widely, depending on soil conditions.

1. Excavate a bed area between 1000mm and 4000mm wide, at least 300mm deep along a level site contour.
2. Excavate a central trench along the full length of the prepared bed, to take a selected Liner. The top of the Liner should be level with the bottom of the prepared bed, and the trench floor not less than 50mm below the pipe from the Septic Tank or sullage distributor. The floor should be level, evenly raked, with no low spots.
3. Allow at least 75mm overlap for each length of EVERTRENCH Liner.
4. Fit Three Brace Bars into each Standard EVERTRENCH Liner, the first 220mm from the inlet end, and then equally spaced along the excavation.
5. Cut the pipe entry hole in one Trench Liner End Cap, and fit the Caps to the Liner. Connect piping from the Septic Tank or Sullage Distributor.
6. Lay geotextile fabric over the full length of the Liner.
7. Place a 150mm layer of 20 - 45mm aggregate material along both sides of the Trench Liner, and at both ends to secure the End Caps, and rake level.
8. Cover the Liner and the floor of the excavated bed with 100mm of coarse sand, then with sandy loam.
9. Lay a final 150mm layer of topsoil less permeable than the parent soil, to help prevent stormwater entering the bed.
10. Leave a mound for natural compaction. Turf may be laid over the area.

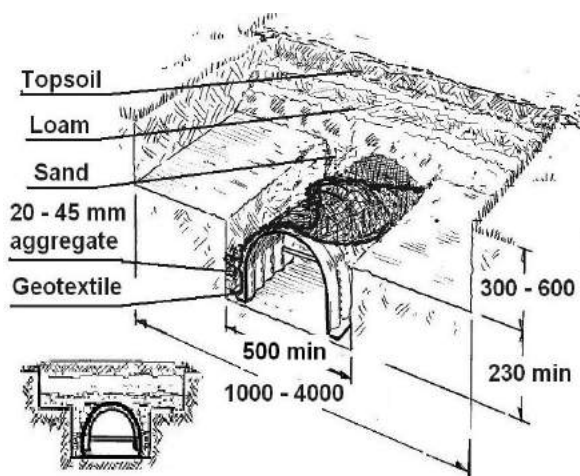

**DO NOT COMPACT the bed area or expose it to traffic**

**EVERHARD INDUSTRIES Pty Ltd recommends a non-woven needle punched Geotextile designed for waste-water disposal land applications**