

TALARIA

AUSTRALIA + NEW ZEALAND



OWNERS MANUAL

TALARIA

STING

Model: STING

An Important Message from Talaria

Dear Customer,

Congratulations and thank you for purchasing the 2022 Talaria STING electric motorcycle; we welcome you to the community of Talaria Electric Motorcycle riders. This manual is designed to provide you with a better understanding of the operation, inspection, and basic maintenance requirements of this electric motorcycle.

Talaria continually seeks advancements in product and quality. Therefore, this manual contains the most current product information available at the time of printing. Because of this, your motorcycle may differ from the information supplied in this Owner's Manual. No legal claims can be made on the basis of data in this manual. When it comes time to sell your Talaria STING, please ensure that this manual stays with the electric motorcycle; it is by law, an important part of the vehicle. If you have any questions concerning the operation or maintenance of your electric motorcycle, please contact the local Talaria dealers.

CAUTION: Please use only Talaria approved parts and accessories for your Talaria Electric Motorcycle. Parts and accessories for your Talaria Electric Motorcycle have been checked and tested for safety and suitability. Talaria is unable to accept any liability whatsoever for parts and accessories which have not been approved.

Vehicle Range

The range of an electric vehicle is defined as the distance the vehicle travels on a single full charge of the battery pack. Your range results are a direct reflection of your riding habits. The more conservatively you ride, the better range you can expect from your Talaria STING electric motorcycle.

Some of the factors which effect range include: speed, acceleration, number of starts and stops, ambient air temperature, as well as changes in elevation. The combination of these factors, as you travel from one point to another, defines your trip profile. In addition, tire pressure and payload are important considerations.

We suggest that you ride conservatively when you first get your Talaria STING electric motorcycle, and get to know your motorcycle and your riding environment. Once you become familiar with the range versus performance of your electric motorcycle, then you can adjust your riding characteristics if you so desire. This applies to riders which are at the edge of the performance envelope.

TALARIA

The Talaria STING electric dirt bike was born to bring cutting edge performance to all riders. It features a CAD designed, light weight frame, a powerful electric motor delivering instant torque, transferred through an intelligent gear drive whilst operating extremely quietly. Its compact, well-balanced structure is very easy to maneuver and requires minimal maintenance. All these features make STING an ideal off-road bike - enjoy the passion and thrill of off-road electric adventures.

POWER PACK. STING is powered by an impressive 60V 38Ah lithium-ion power pack, which is 2280 watt-hours, and easily swappable. The power packs can be exchanged with another fully charged power pack in seconds for limitless range. With electric automobile grade LG 21700 lithium-ion battery cells, state of the art programmed BMS, and optimized internal structure, this battery pack is enabled to ensure the bike brings you safe, hi performance off-road riding.

FRAME. Cutting-edge engineered frame is pure purpose built, light weight and compact. Using 6061 aluminum alloy, and superior forging process by 6000 tons of pressure, the frame is qualified to assure you a safe, fun and fearless riding experience through even the toughest terrains.

CONTROLLER. With the best available hardware, superb layout, and ingenious programming, the 6000w controller is enabled to have an extraordinary ability for transient current impact resistance, ultra strong anti - interference, high-precision EABS voltage and discharge current control, error inspection, high and low temperature protection, anti-runaway, and smart energy regeneration. This guarantees to bring the rider a powerful, exciting, and safe riding experience with a respectable range.

POWERTRAIN. The customized combination powertrain design is just perfect for the light weight electric MX bike. The high efficiency brushless permanent magnet synchronous mid-drive motor, with top-class magnet material and advanced processing, is available to output 34N.m peak torque, as well as to have 284N.m peak torque to the rear wheel. With exquisitely crafted high accuracy gears, the gearbox runs even quieter and is much more durable than any belt drive systems. It's time to say goodbye to that broken belt anxiety.

DASH. The dash features a high-contrast OLED display, this will offer riders a clear data display with low power consumption. With CAN communication, the dash is available to have data transfer with the battery pack's BMS and the motor controller. The display menu provides a range of information, which include top/average speed, range, battery data, riding mode, error codes, regen level and more. The dash is also adjustable to allow different settings for different wheel size, sprocket size, motor regen levels, and change between KM/H and MPH to enhance the compatibility of the bike.

THROTTLE. The Sting uses a unique gear twist structure design, the core parts of the throttle can be well protected, even if the throttle tube suffers some impact damage, the throttle is still workable. And with the automobile level encoder, the throttle can enable the rider to control the acceleration with ease. It's a specialized product and fantastic for an electric off-road bike.



TABLE OF CONTENTS



- 01** Safety Information
- 03** Components
- 05** Components Functions
- 07** Starting and Operating
- 09** Charging and Batter Pack Information
- 012** Pre-Riding Inspection
- 014** Regular Inspection and Maintenance
- 016** Technical Specifications
- 018** Errors and Solutions
- 027** Circuit Diagram



SAFETY INFORMATION

General Safety Precautions

This is a performance electric motorcycle and should be treated with extreme caution.

- Proper safety gear, including a regionally approved helmet, eye protection, riding boots, gloves and protective clothing should be worn while riding to reduce the risk of potential injury. We highly recommend the use of full height riding boots. It is not recommended to ride without the correct protective clothing.
- Read all additional warnings and product instructions in this owner's manual, as well as safety labels, before operating your electric motorcycle.
- Never permit a guest to ride your electric motorcycle without proper instruction.
- Never use alcohol or mind-altering drugs before operating your electric motorcycle.
- Persons unwilling or unable to take responsibility for their actions should not use this electric motorcycle. You assume all responsibility while operating your motorcycle. The seller assumes no liability for misuse or operator negligence.
- Prior to each use the rider must check everything carefully, and the charge level of the batter pack as indicated on the battery pack display or dash display charge indicator.
- Your safety depends in part on the good mechanical condition of the motorcycle. Be sure to follow the maintenance schedule and adjustment requirements contained in this manual. Be sure you understand the importance of checking all items thoroughly before riding.
- Modifications to this electric motorcycle may render the vehicle unsafe and may cause severe personal injury. Talaria cannot be held liable for non-approved modifications.
- Be very careful when loading or adding accessories to your motorcycle. Large, bulky, or heavy items may adversely affect the handling and performance of your electric motorcycle. Overloading may ever cause the safety hazards and vehicle damages.

Important Operating Information

Several operating considerations are listed below:

- Always turn the key switch to the OFF position when not actively riding. It is very easy to forget that the electric motorcycle is powered up because it is silent. An accident can occur if the electric motorcycle is left powered up while getting on or off the electric motorcycle.
- Use the rear brake when you are stopped on an incline. Do not hold the motorcycle using partial throttle or damage to the motor may occur.

- If you plan on riding again the next day or the battery pack's stage of charge is less than 30%, plug the battery pack or your electric motorcycle into an AC power source to recharge it. Always use the supplied charging cable as it has been designed for use with your electric motorcycle's electrical components.
- While unplugged with the key in the OFF position, the electric motorcycle's electronics will consume a very small amount of power and the battery pack will drain extremely slowly. If the electric motorcycle has been unused for more than 30 days, turn the circuit switch off, as well as unplug the battery cable. For every 3-month, charge the battery one time to about 60% power, and store the battery pack in a dry and ventilated place.

CAUTION. Only charge the Talaria battery pack with the approved Talaria accessory charger.

Vehicle Identification Number (VIN) & Motor Number

- The VIN is a 17-digit number stamped on the head tube of the frame. Do not alter or remove this number as it is the legal identifier for your electric motorcycle.
- The motor number is stamped on the motor enclosure.



COMPONENTS

Please refer to the illustration to identify the components and be familiar with the electric motorcycle.

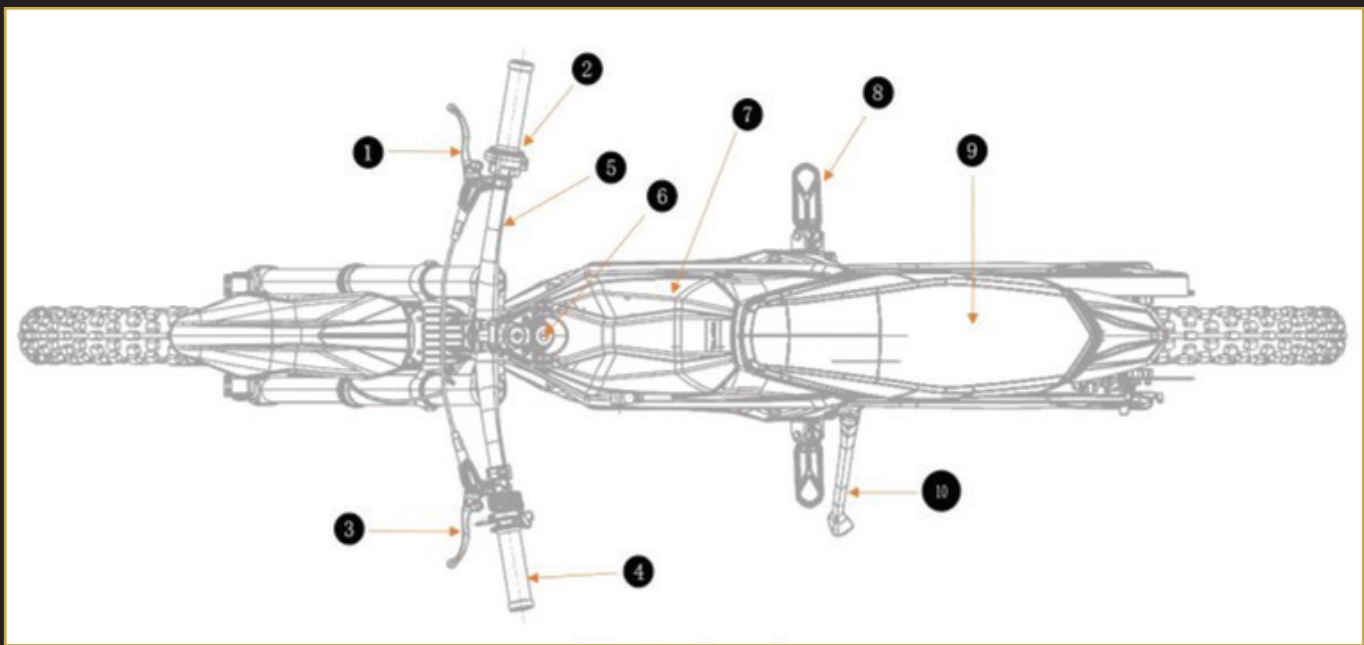

Illustration 1

1-1 Front Brake Lever

1-2 Rear Brake Lever

1-3 Throttle Control

1-4 Handle Grips

1-5 Handlebar

1-6 Key Switch

1-7 Battery Pack Holder Cover

1-8 Footpeg

1-9 Seat

1-10 Side Kickstand

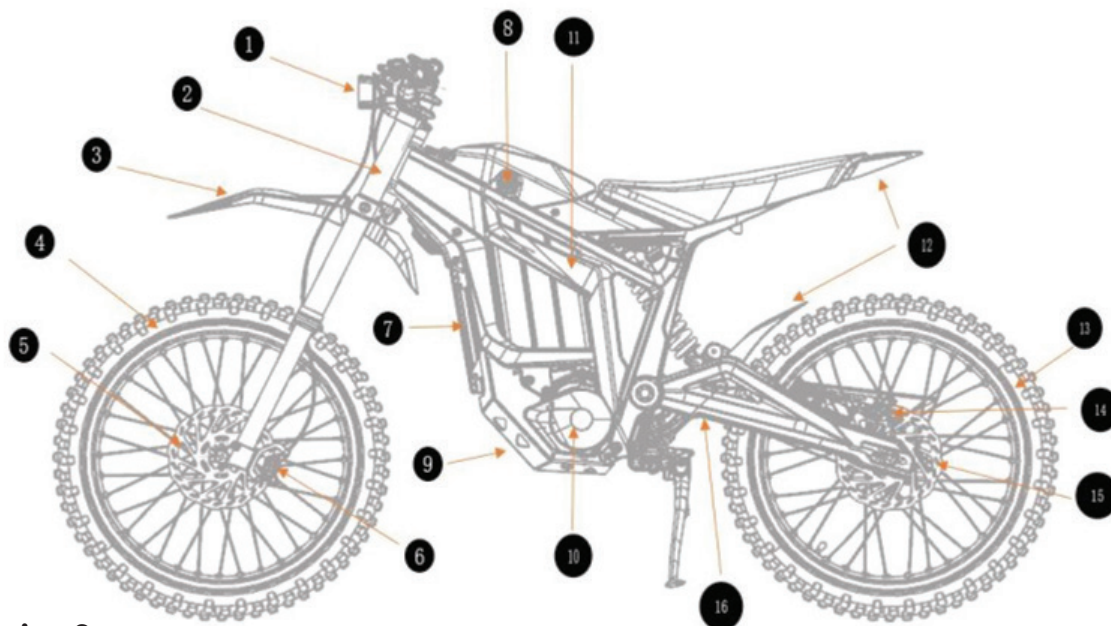

Illustration 2

- | | | |
|-----------------------------|--------------------------------------------|-----------------------------|
| 1-1 Headlight | 2-7 Controller | 2-13 Rear-Wheel |
| 2-2 Front Fork | 2-8 Battery Pack Charging Interface | 2-14 Rear Brake Pump |
| 2-3 Front Fender | 2-9 Motor Protector | 2-15 Rear Brake Disc |
| 2-4 Front Wheel | 2-10 Gearbox Cover | 2-16 Rear Fork |
| 2-5 Front Brake Disc | 2-11 Chassis | |
| 2-6 Front Brake Pump | 2-12 Rear Fenders | |

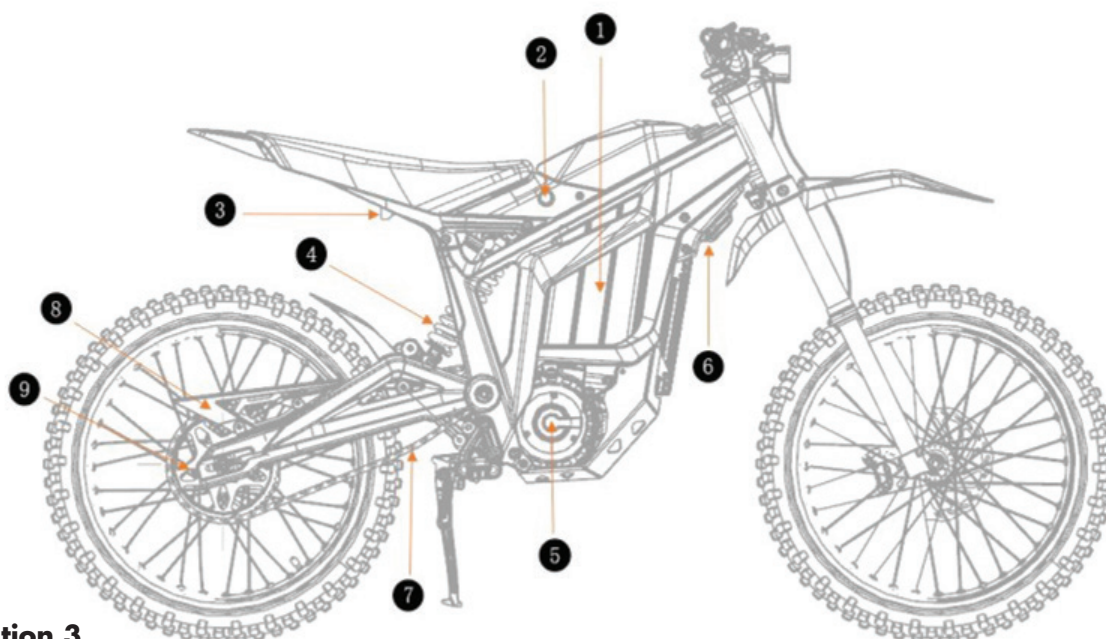

Illustration 3

- | | | |
|-------------------------------------|--------------------------------|-------------------------|
| 3-1 Battery Pack | 3-4 Rear Shock Absorber | 3-7 O-Ring Chain |
| 3-2 Battery Pack Holder Lock | 3-5 Motor Assy | 3-8 Chain Guide |
| 3-3 Tail Light | 3-6 Horn | 3-9 Sprocket |



COMPONENT FUNCTIONS

4-1 Setting Button (Not available while riding)

4-2 Status Display (including WAIT/READY/ECO/SPORT/ERROR).

4-3 Real-Time Speed

4-4 Battery Display

4-5 Single Range

4-6 Re-Gen Levels Indicator (1,2,3,4, re-gen levels can be set).

4-7 Button M (when the electric motorcycle is switched on and stationary, hold down the setting button for a while to enter into the dash setting. Once the dash setting is finished, press button M to confirm and save the dash setting. Besides this, button M is also used to switch the riding modes between ECO and SPORT).

4-8 & 4-9 Selection Buttons (Up/down) (When the electric motorcycle is switched on and stationary, hold down the setting button for a while to enter into the dash setting. Then, you can use the selection buttons to select the setting by up and down. Besides this, regularly, the selection buttons are also used to select the re-gen levels).

4-10 EXIT (exit any settings).

4-11 Riding DATA (Including average energy consumption, maximum speed, average speed, startup running, time, mileage).

4-12 Switch for KM/H and MPH.

4-13 Wheel Diameter Setting (17" or 19").

4-14 Gear Ration Setting.

4-15 Battery Pack Information (Battery voltage, capacity, cycle index).

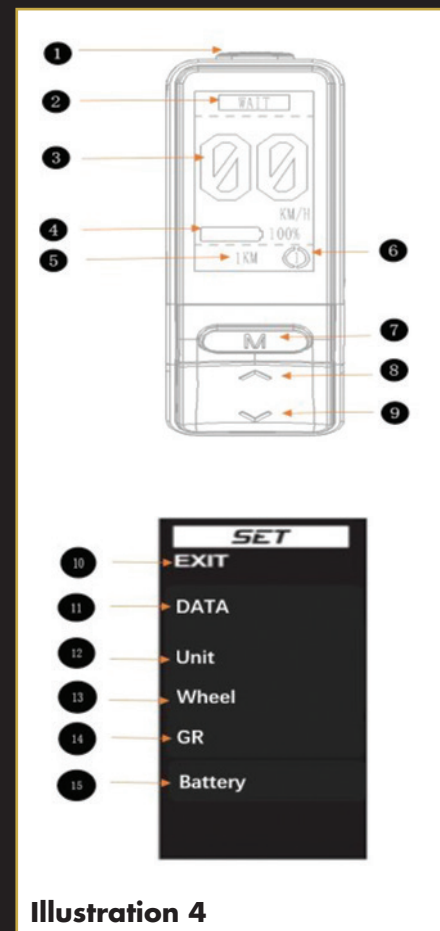

Illustration 4

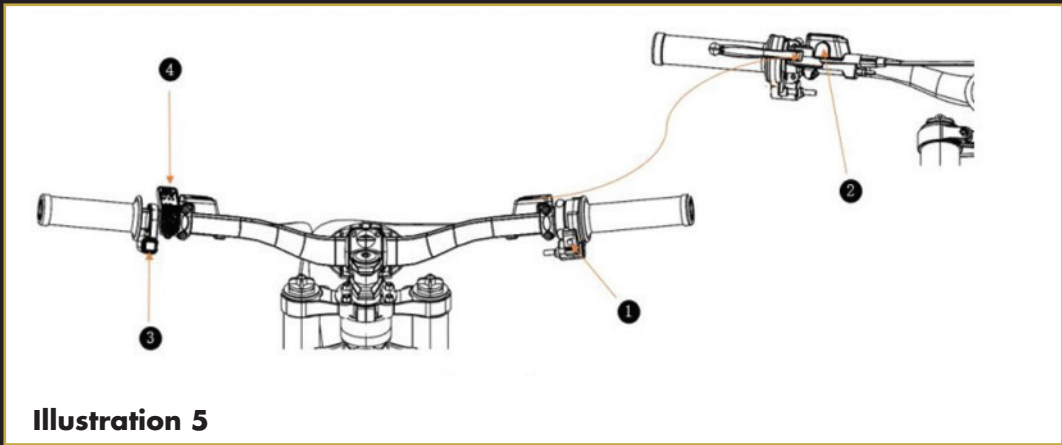

Illustration 5

5-1 Start Button. For the consideration of safety, after the electric motorcycle is switched on, it will not move when you throttle the electric motorcycle. On the dash, displayed is WAIT. Once you are ready to ride, press this start button, it will display READY on the dash, then you can throttle the electric motorcycle to ride.

5-2 Brake Fluid Level Indicator

5-3 Horn Button

5-4 Dash

SPECIAL NOTICE.

- When you select "ECO" mode, the power output and speed acceleration are not so active. It is suitable for fresh riders, as well as the riders who want a longer range.
- When you select the "SPORT" mode, the power and speed acceleration is active. It is suitable for motor cross riding. In this case, for your safety, please make sure you are skilled, and well geared up.
- To avoid battery pack overcharge, the re-gen function will work only after the batter SOC (state of Charge) is less than 90%.

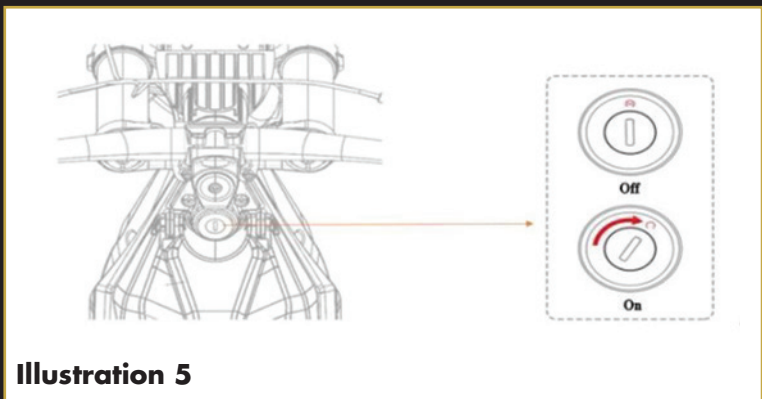

Illustration 5



STARTING AND OPERATING

Starting

Pre-starting inspection is required.

- Before starting, firstly, please make sure the circuit breaker, which is inside of the battery pack holder, is switched on. Secondly, well lock the battery back holder cover, and unplug the key to turn the key switch on, and then check whether all other switches, dash and horn work well. Finally, hold down the front and rear brake lever to check whether the brakes work correctly.
- Motor Starting: After the checking, fold up the side kickstand (WAIT is displayed on the dash), and when the rider is ready, press the start button to start the motor. READY will then be displayed on the dash. This means the electric motorcycle is ready to go, and the rider can throttle the electric motorcycle to ride. This electric motorcycle has the power-off protection device on the side kickstand. Unless the side kickstand is folded up, the motor will not start.

Throttle Control

- When the throttle is in the closed position, there's no power to energize the motor. Twist the throttle in a counter-clockwise rotation to energize the motor and accelerate the electric motorcycle. Twist the throttle in a clockwise rotation to decelerate the electric motorcycle. Release the throttle, and it will snap back to the closed position to de-energize the motor.

WARNING. Please twist the throttle properly. Progressive twist of the throttle could cause damages to the throttle and lose control of the electric motorcycle. In this case, may lead to serious injury or death.

Braking

- On the right handlebar is the hand operated brake lever. The brake lever controls the front brake when the lever is squeezed. On the left handlebar is the hand operated brake lever control the rear brake when the lever is squeezed.
- When braking, the throttle should be in the closed position. If you only apply front brake or rear brake, this could possibly cause sideslips, and lead to serious injury or even death. Therefore, we strongly recommend you apply both front and rear brakes together.

WARNING. If you apply the front or rear brake hard enough, it is possible to lock the wheels. This could cause you to lose control of the electric motorcycle and could lead to serious injury or even death. Progressive use of the brakes should bring the electric motorcycle to a complete stop without locking the wheels. Your Talaria STING electric motorcycle is a light-weight performance product and therefore practice is strongly recommended to perfect safe emergency stops.

Riding Cautions

- When you ride the electric motorcycle, if there are no emergency circumstances, it is strongly suggested you do not make quick accelerations and decelerations. With less quick accelerations and decelerations, it will protect your electric motorcycle and keep it in a good condition, keep you away from hazards, reduce power consumption, and increase the range and life-time of the electric motorcycle.
- When you ride the electric motorcycle on rainy and snowy days, the ground is wet and slippery. In this case, we strongly suggest you pay more attention to the riding environment around you, and keep a clear mind for fast reactions in case of any emergency circumstances. After your electric motorcycle is washed or the wading riding, the braking effect may be temporarily reduced. For your safety, this case, we suggest you slow down the speed, and gently squeeze the brake levers to apply the brake for some time until the brakes work normally.
- We suggest you ride the electric motorcycle carefully and slowly in light rain and snow. However, we strongly suggest you do not ride the electric motorcycle in heavy rain and snow.
- We suggest you ride the electric motorcycle carefully and slowly on the ground with puddles. If any puddles submerge the hub of the wheel, this may cause the motor and brake to work incorrectly. We don't suggest you ride this electric motorcycle in the puddles for a long time. If the electronic parts are submerged for a long time, this may cause damage to the electronic parts and lead to serious hazards.

CAUTION.

- The side kickstand is only designed to support the electric motorcycle. We suggest you do not sit on the electric motorcycle with the side kickstand unfolded. Otherwise, the side kickstand may be damaged.
- We suggest you do not park the electric motorcycle on the soft ground or any slopes, otherwise, your electric motorcycle may tip over easily.
- We strongly suggest you do not expose your electronic motorcycle to the rain for long periods of time or use the high-pressure washer to flush your electronic motorcycle as the positions may have electronic parts. Otherwise, it is possible to cause failure to the electronic parts.

Parking

- For your safety, please ride slowly when parking, observe carefully before parking, and choose the correct place to park your electric motorcycle.
- Squeeze the brake levers to apply the brakes to stop your electric motorcycle, release the throttle to snap back to the closed position, and then switch off the key switch and unplug the key.
- After you dismount your electric motorcycle, please stand at the left side, and unfold the side kickstand to support the electric motorcycle. Before leaving, please make sure all the locks are well locked, and unplug the key to take with you.

Warning.

Please do not twist the throttle unless you are sitting and ready to ride the electric motorcycle. After you have stopped the electric motorcycle, and before you release the brake levers, please switch off the key switch, otherwise, may cause unexpected hazards.



CHARGING AND BATTERY PACK INFORMATION

The Talaria battery pack leverages proven battery cell chemistry, configuration, and enhanced reliability. With the high-performance lithium-ion battery cells inside of the battery pack, it's well designed to operate under normal temperatures and environmental conditions based on 60V voltage. The battery pack should not be used outside of the range of -20°C to 30°C. The performance and lifetime of the battery pack will have a reduction if the battery pack is used outside of the range of -20°C to 50°C. The battery pack should not be charged below 0°C.

CAUTION.

- The battery pack should not be charged below 0°C. Users should wait for the temperature to be equal or above 0°C, and then, can charge the battery pack. The battery pack may otherwise become damaged.
- When the temperature is low, it is normal that the performance of the battery pack will have a reduction, and lead to a relatively shorter range. Once the temperature reaches regularity, the performance of the battery pack and the range will be recovered automatically.
- The battery pack has a self-protection function, and it will work to protect the battery pack from any damages by over charge and discharge. Frequently over discharge will cause the performance of the battery pack to have a reduction. When the battery power is low, please charge the battery pack as soon as possible.
- The battery pack has no memory function and can be charged frequently. Charging the battery pack frequently will keep it in good condition.
- If the battery pack is not used for a prolonged period, please charge the battery pack once every 3 months to about 60% power, switch off the circuit breaker, unplug the discharge connector, and store the battery pack in a dry and ventilated place. If the battery pack is not charged for a long time, the low voltage self-protection function will be activated automatically. You will then need to re-activate the battery pack to use again.
- Once the battery pack is fully charged, the voltage should be in the range of 66.5V to 67.2V. If the voltage is out of this range, the battery pack will not be fully charged and this may cause problems. Please contact the local dealer for a solution.

CAUTION.

If the motor and controller is overheated, or the battery pack is low in power, the self-protection function will act to reduce the output or even shut down the electric motorcycle. However, this is not a failure or error. Once the motor and controller has cooled down, or the battery pack is charged, the performance of the electric motorcycle will recover to usual.

Charging and Charger Information

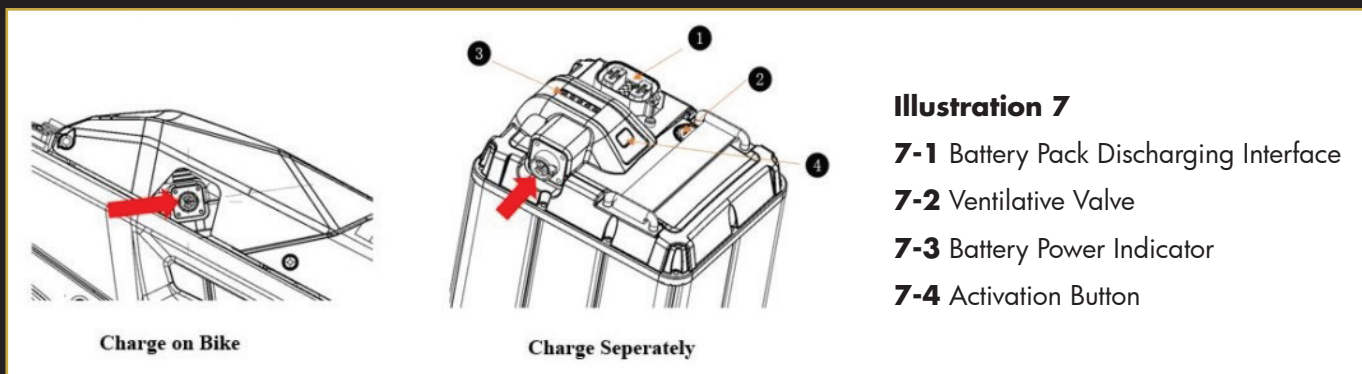

- Only charge the Talaria battery pack with the approved Talaria accessory charger. Any other unapproved chargers may cause damages to the battery pack, and lead to serious hazards.
- Check the charger to make sure the input voltage marked on the charger is correct for the local power supply voltage (AC 110V / AC 220V).
- **Caution:** When you charge the battery pack, firstly please connect the DC input connector with the battery pack charging interface. Then, connect the AC power cord with the power supply socket. Once the battery pack is fully charged, please disconnect the AC power cord. Once the indicator is extinguished, disconnect the DC input connector.
- When the battery pack is charging, the red indicator will twinkle. Once the battery pack is fully charged, the green indicator will remain on. Usually, it will take about 4 hours to fully charge the battery pack.
- Once the battery pack is fully charged, the charging will shut down automatically. However, in consideration of safety, we suggest you disconnect the AC power cord from the power supply socket within 6 hours after the battery pack is fully charged.
- Unqualified or unskilled people should not disassemble the battery pack, as damage may be caused to the battery pack leading to serious hazards.
- When the battery pack is inactive, you can activate it via the activation button on the battery pack or by connecting the charger.

CAUTION.

- Please ensure children are not able to reach the battery pack while charging.
- Once the battery pack has finished discharging, it will have a high internal temperature. Please do not charge the battery pack immediately. Before charging, it is suggested to cool down the battery pack in a well-ventilated place for 30 minutes.
- We suggest allowing the battery pack to rest for 10 minutes before use, after being charged.
- Please ensure the battery pack is not covered while charging. The charger is designed for use in-doors, and the charger should be used and stored in a dry, ventilated place.
- If there is a strange smell, the temperature becomes too high while charging, or another issue arises that prevents the battery from being fully charged, please stop charging immediately and send the battery pack to the qualified maintenance store for checking.

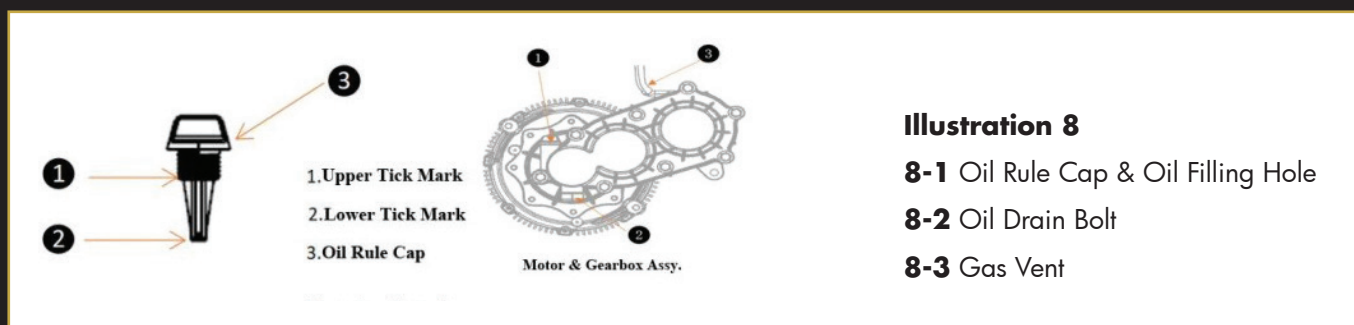

Usage and maintenance of gearbox and controller

- Regularly check whether the gearbox fixing screws are loose, and the lubricating oil level is between the upper and lower tick marks. Please do not ride electric motorcycle if the gearbox is short of or without lubricating oil as this may cause damage to the gearbox. After the running-in period, replace the lubricating oil every 1000KM (lubricating oil grade: CL-5 85W/90). To replace the lubricating oil, firstly loosen the oil rule cap screw on the gearbox, and then loosen the oil drain bolt to drain out the used lubricating oil. If there is no used lubricating oil draining out, please clean the dirt on the magnetic core of oil drain bolt, and then fix it back on the gearbox, and fill 120-150ml of lubricating oil into the gearbox through the oil filling hole.
- Regularly check whether the connection wires between motor and controller are loose, and whether the insulation of the wires is in good condition.
- Regularly check whether the fuse is loose or melted.
- It is not recommended to ride your electric motorcycle in deep puddles. This may cause the motor to work incorrectly.
- It is not recommended to use a high-pressure washer to flush the motor and controller.



PRE-RIDING INSPECTION

Tire Inspection

- Please check the tire pressure is correct before riding.

CAUTION.

- Abnormal tire pressure, tire damages, and tire wear will cause serious potential safety hazards.
- When the tire pressure is low, the tire will be easily worn, and cause the steering to be inflexible, as well as lead to low speed and less range.
- When the tire pressure is high, riding will be uncomfortable, the tires will be easily worn, and can even cause a blowout and lead to serious injury. According to the tire depression, when tires contact the ground, you can identify if the pressure is appropriate. The suggested tire pressure is 225kpa and the rear tire is 225kpa (low tire pressure will lead to slow speed and less range).

NOTE.

- The suggested tire pressure is based on the manufacturer's test result. It is only for your reference. When you ride the electric motorcycle, you can adjust the tire pressure according to your weight, ground condition, and local weather conditions, etc.
- We suggest regularly checking the tires for cracks and abnormal wear before riding.
- We suggest regularly checking there are no nails, sharp-edged pebbles, or broken glass stabbed in to the tire before riding.
- We suggest replacing the tires when the tire tread is worn out for equal or more than 2/3.
- We suggest checking the spokes of the wheels are not loose before riding.

CAUTION.

- The run-in period for the electric motorcycle is 300KM. First maintenance needs to be done after the run-in period, and then completed every 1000KM.

Inspection of dash, horn, brakes, and replacement of gearbox lubricating oil

- Switch on the key switch to inspect whether all the indicators are well displayed on the dash.
- Press the horn button to inspect the horn works properly.
- Squeeze the left and right brake levers to inspect the front and rear brakes work well.
- Replace the gearbox lubrication oil after the run-in period (lubricating oil grade: CL-5 85W/90).

Inspection of handlebar and seat

- Please check handlebars and seat are in the proper position and well fixed.
- If you find any problems during the inspection, please read the related content of this manual or contact the local dealer for solution.

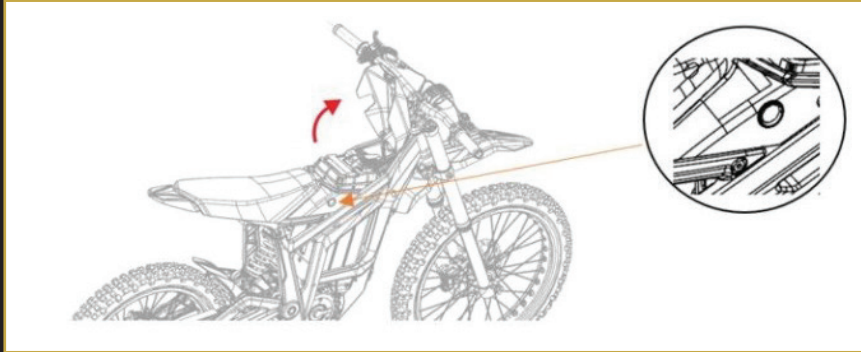

Battery Pack Pull Out

- Switch off the key switch and take key to unlock the battery pack holder cover. The battery pack will then be in sight.
- Switch off the circuit breaker, unplug the battery pack discharge connector, and then pull out the battery pack by lifting upward.

Battery Pack Installation

- Use the key to unlock the battery pack holder cover.
- Install the battery pack by pulling downward, however please pay attention to the direction (battery pack charging interface should be on the left side). After the battery pack is installed properly, plug in the battery pack discharging connector, and switch on the circuit breaker. Finally, lock the battery pack holder cover, and take out the key.

WARNING.

- Before pulling out or installing the battery pack, please switch off the circuit breaker.
- The battery pack discharge connector should be correctly plugged in. Otherwise, the battery will not be identified, causing the electric motorcycle failure to run.



REGULAR INSPECTION AND MAINTENANCE

- For your safety, as well as to increase the lifetime of the electric motorcycle and enjoy safe and comfortable riding, it is strongly recommended to carry out inspections and maintenance on your electric motorcycle regularly. If your electric motorcycle is not used for a prolonged period, regular inspections and maintenances are still required.
- The first inspection and maintenance need to be conducted after the 300KM run-in period.
- Follow this manual and ensure full care and safety when conducting inspection and maintenance.
- When you conduct inspection and maintenance, it is recommended to park your electric motorcycle on flat ground.
- If the emergent inspection and maintenance is required to do during riding, pay attention to the surrounding environment and situation and find a safe place to finish the inspection and maintenance.
- If any problems are found by inspection, please ride your electric motorcycle after solving the problems.
- If there are any problems you are unable to find a solution to yourself, please contact the local dealer.

CAUTION.

- Both front and rear brakes are disc brakes. Once the brake pads have severe wear and tear, they should be replaced.
- For daily use, please keep the disc brake clean. In order to ensure the silt and oil contamination does not adhere to the disc brakes, we suggest you clean the disc brakes after every off-road ride, and regularly clean the disc brakes after non-off-road riding.

Inspection of Operating Components

- Please inspect the front fork for any faults, such as bends, deformation, damages, loose parts, oil leaking, and so on, before riding. Hold the handlebar to compress the front fork to see if there is any noise caused by the faults of front fork. If there are any faults found during inspection, please contact the local dealer for maintenance.
- Inspection of the rear shock absorber.
- Inspection of the brake levers. Inspect when the free travel of brake lever is in range of 15mm to 30mm. if the free travel is out of this range, please adjust.
- Inspect the brake performance. Ride the electric motorcycle slowly on safe ground, squeeze the front rear brake levers to check the brakes perform properly. If there is abnormal brake performance, please check if the brake pads need to be cleaned, replaced, or brake oil needs to be added. If there are still problems, please contact the local dealer for solution.

Inspection of Tires, Wheels System, Transmission, etc.

- Please inspect the tire pressure by the tire pressure meter before riding.
- Inspect the tire for cracks, damages, abnormal wear, and sharp objects on the tires before riding.
- Please check if any spokes are loose before riding.
- Please inspect the tension of the chain, and make sure the chain is tensioned sufficiently before riding.
- As tires will be in contact with the ground during riding, nails, sharp-edged pebbles, and broken glass can easily stab into the tires causing damage, and lead to serious hazards. Therefore, when riding the electric motorcycle, we suggest paying attention to the ground situation, and avoid riding the motorcycle on ground covered in such objects. Before every ride, we suggest you inspect the tire for cracks, damages, abnormal wear, or nails, sharp-edged pebbles, and broken glass before every ride.
- Please check the tire tread before riding. If the tire tread is worn out equal or more than 2/3, the tire will need to be replaced with new tire(s).

Inspection of Battery Pack

- The electric motorcycle is equipped with 3-Element Lithium-ion battery pack. Once the battery pack is fully charged, please measure the voltage of the positive and negative poles using a multimeter. The proper voltage for a fully charged battery pack should be in the range of 66.5V to 67.2V. Battery pack will not be fully charged or may incur damages otherwise. Please contact the local dealer for a professional inspection and maintenance.

CAUTION.

- Please switch off the circuit breaker before pulling out battery pack.
- If battery pack is hard to push back downward once installed, please pull out the battery pack to check if there is an obstruction.

Fuse Replacement

- If the dash, horn, or lights of the electric motorcycle do not work after the circuit breaker and key switch are turned on, it is possible the fuse has melted. In this case, please switch off the circuit breaker, and replace the fuse.
- Unlock the battery pack holder cover and pull-out battery pack. You will then find the fuse box at the front of the circuit breaker. Open the fuse box.
- Remove the melted fuse and replace with a spare fuse. Ensure the fuse box is closed well, install the battery pack, and lock the battery pack holder cover.

CAUTION.

- Please make sure the spare fuse is properly fixed. If the spare fuse is loose, serious fault or hazards may occur.
- The spare fuse should be the correct recommended type and spec, otherwise, the fuse will not be melted to work out the protection when it is necessary.
- If the spare fuse is melted in a short time after it's replaced, please contact the local dealer to check for any other possible reasons and fix the problem.
- The fuse box should not be flushed by water.



TECHNICAL SPECS OF STING

Motor Type	Pmsm (Permanent Magnet Synchronous Motor)
Mounting Position	Middle Of The Frame
Motor Weight	7.0kg
Motor External Diameter	Φ180mm
Motor Axial Length	120mm
Motor Peak Efficiency	92%
Motor Cooling Method	Air-Cooled
Controller Type	Foc
Controller Weight	2kg
Controller Dimension	248mm X 128mm X 50mm
Controller Peak Efficiency	92%
Highest Work Temperature	100°C
Norminal Voltage	60v (Dc)
Peak Power	3000w
Norminal Torque	≥5.7n.m
Peak Torque	34n.m
Torque On Rear Wheel	284n.m 944t Sprocket)
Gear Ratio	8.35 944t Sprocket
1st Transmission Mode	Gearbox
2nd Transmission Mode	Chain
Battery Pack	60v / 38.4ah
Battery Pack Measurement	170 x 140 x 380
Battery Pack Weight	12.85kg
Battery Cell	21700 Lithium-Ion Cell
Dash	Yes
Re-Gen Adjust Method	4-Level Adjustment
Chasiss Material	No. 6061 T4 & T6 Aluminum Alloy

Chassis Process Method	Forged By 6000 Tons Pressure
Led Headlight	Yes
Front Fork	Hydraulic Front Fork
Rear Absorber	Mono Spring Shock Absorber
Wheel Type & Size	Wire Wheels, Front/Rear 19inches
Tire Size	Fr.: 70/100-19; Rr.: 80/100-19
Tire Brand	Cst Brand Tire
Top Speed	≥70km/H (With 44t Sprocket)
Max. Range	≥70km @ 40km/H
N.W.	63kg (Battery Pack Included)
Vehicle Dimention	1850mm x 770mm x 1075mm
Seat Height	870mm
Wheelbase	1225mm
Handle Bar Length	760mm
Min. Ground Clearance	280mm

Notice: Talaria continually seeks advancements in product design and quality. Therefore, above specs are based on current product information available at the time of printing. Because of this, your motorcycle may differ from the above specs. Please note this.





ERRORS AND SOLUTIONS

Switch on the key switch, motor does not work

Possible Reasons	Solutions
Discharge wire loose.	Properly fix the discharge wire connection.
Throttle control connector falls off.	Properly plug the connector.
Motor wires loose or fall off.	Reconnect the motor wires properly.
The brake lever does not return or the brake sensor fails.	Inspect the brake lever and brake sensor. Solve the problem by repairing or replacing the relative parts.

Failure of throttle control or reach to top speed

Possible Reasons	Solutions
Low battery voltage	Fully charge the battery
Failure of throttle control	Contact the local dealer to replace the throttle control

About Short Range

Possible Reasons	Solutions
Low tire pressure.	Inflate the tire to the proper pressure.
Battery pack is not fully charged.	Fully charge the battery pack.
Charger failure.	Repair or replace the charger.
Battery pack has aged through long time use or damage.	Replace with new battery pack.
The ground with many slopes, and ride against the wind.	It's normal that the range will reduce in such riding conditions.
Frequently twist the throttle for quick acceleration and deceleration, or overloading.	A good riding habit can help you to get a longer range for one charge.

Charger does not charge the battery pack

Possible Reasons	Solutions
The plug of the charger is loose or falls off.	Please properly connect the charger plug with the battery pack charging interface.
Failure of the charger.	Repair the charger. If it is not repairable, replace a new charger.

Abnormal noise and vibration found during riding

Possible Reasons	Solutions
The tension of the chain is not properly adjusted	Please adjust the tension correctly via the tensioner.

Other errors

- When you have any errors not mentioned above or you cannot identify, please contact the local dealer to offer a professional inspection and maintenance.

TALARIA STING TL3000 ERROR CODES & SOLUTIONS

ITEM	ERROR CODES (MX VERSION)	ERROR CODES (L1E VERSION)	DESCRIPTION	ERROR ANALYSIS	SOLUTIONS	REMARKS
1	E01	00001	Protection IC error.	The inner communication of the chip is disconnected.	Re-start the bike.	If the error code is still showing on the dash, please send the bike to the nearest dealer to inspect and repair.
2	E02	00002	Battery cell connection wire disconnected.	The connect wire for cells are not well welded, cause the welding spot loose, fall off, or connection wire poor contact.	Re-start the bike.	If the error code is still showing on the dash, please send the bike to the nearest dealer to inspect and repair.
3	E03	00003	Voltage of battery cells are not balanced.	The difference of battery cells is more than 500mV, this error code will display on the dash.	Re-start the bike.	If the error code is still showing on the dash, please send the bike to the nearest dealer to inspect and repair.
4	E04	00004	Battery capacity measurement error.	Don't have this error for STING's battery. Just a default setting error.		
5	E05	00005	Storage error.	Record devices detected failure.	Re-start the bike.	If the error code is still showing on the dash, please send the bike to the nearest dealer to inspect and repair.
6	E06	00006	Time display error.	Time device detected failure.	Re-start the bike.	If the error code is still showing on the dash, please send the bike to the nearest dealer to inspect and repair.
7	E07	00007	Discharge MOS error.	Discharge circuit detected failure.	Re-start the bike.	If the error code is still showing on the dash, please send the bike to the nearest dealer to inspect and repair.
8	E08	00008	Charge MOS error.	Charge circuit detected failure.	Re-start the bike.	If the error code is still showing on the dash, please send the bike to the nearest dealer to inspect and repair.
9	E09	00009	Over charge error.	1. Charging voltage is higher than single battery cell's over charge protection voltage 4250mV. 2. Misinformation of BMS .	Re-start the bike.	When this error code display on dash, will not affect the riding, but cannot charge. After the re-start, if the error code still display on dash, please send the bike to the nearest dealer to inspect and repair.

ITEM	ERROR CODES (MX VERSION)	ERROR CODES (L1E VERSION)	DESCRIPTION	ERROR ANALYSIS	SOLUTIONS	REMARKS
10	E10	0000A	Level 1 over discharge error.	The low battery voltage has caused the error codes display on dash.	Users need to charge the battery immediately.	
11	E11	0000B	Level 2 over discharge error.			
12	E12	0000C	Level 1 over discharge current error.	Battery discharge current is higher than the level 1 over current value, and caused the over current protection function start to work.	Stop the over current discharge or reduce the discharge current for 1 minute, the error will disappear automatically.	If the error code is still showing on the dash, please send the bike to the nearest dealer to inspect and repair.
13	E13	0000D	Level 2 over discharge current error.	Battery discharge current is higher than the level 2 over current value, and caused the over current protection function start to work.	Stop the over current discharge or control the discharge current $\leq 110A$, or check whether there's the short circuit? If yes, eliminate the short circuit.	If the error code is still showing on the dash, please send the bike to the nearest dealer to inspect and repair.
14	E14	0000E	Over charge current error.	Charging current is higher than the protection charge current value.	Check to see if the charger is the correct one to match the battery.	If the battery is charged by Talaria stock charger and still shows over charge current error, please send the bike to the nearest dealer to inspect and repair.
15	E15	0000F	Software start failure error.	With load electric capacity to connect the battery, if the load electric capacity is too much, will cause the software start failure.	Please follow the owner's manual to turn on the powertrain and start the riding.	
16	E16	00010	Pre-charge time-out error.	1. BMS failure. 2. Failure of the charger or the charger is not match with the battery.	1. If it's caused by BMS failure, need to replace the BMS. 2. If it's caused by the charger failure or unmatched charger, please replace the new correct charger.	If the solution cannot solve the error, please send the bike to the nearest dealer to inspect and repair.
17	E17	00020	MOS temperature sensor failure error.	MOS Temperature sensor failure.	Re-start the bike.	If the solution cannot solve the error, please send the bike to the nearest dealer to inspect and repair.
18	E18	00030	Battery cell temperature sensor failure error.	Battery cell temperature sensor failure.	Re-start the bike.	If the solution cannot solve the error, please send the bike to the nearest dealer to inspect and repair.

ITEM	ERROR CODES (MX VERSION)	ERROR CODES (L1E VERSION)	DESCRIPTION	ERROR ANALYSIS	SOLUTIONS	REMARKS
19	E19	00040	Battery discharge overheated error.	When the battery pack is discharging, the battery pack inner temperature is overheated.	Stop to riding the bike until the discharge overheat protection unlocked.	It's strongly suggested to use the bike as per the owner's manual.
20	E20	00050	Battery charge overheated error.	The high battery cell temperature caused this error.	Stop to charging the battery until the charge overheat protection unlocked.	It's strongly suggested to use the bike as per the owner's manual.
21	E21	00060	Battery discharge low temperature error.	When the battery pack discharges in very low temperature, the battery will carry out the protection function for low temperature.	Stop to riding the bike until the low temperature protection unlocked.	It's strongly suggested to use the bike as per the owner's manual.
22	E22	00070	Battery charge low temperature error.	When the battery pack is charged in very low temperature, the battery will carry out the protection function for low temperature.	Stop to charging the battery until the low temperature protection unlocked.	It's strongly suggested to use the bike as per the owner's manual.
23	E23	00080	Battery discharge, MOS overheated error.	It's caused by the overheated MOS when the battery pack is discharging.	Stop to riding the bike until the overheat protection unlocked.	It's strongly suggested to use the bike as per the owner's manual.
24	E24	00090	Battery charge, MOS overheated error.	It's caused by the overheated MOS when the battery pack is charging.	Stop to charging the battery until the discharge overheat protection unlocked.	It's strongly suggested to use the bike as per the owner's manual.
25	E25	000A0	Soft-start circuit overheated error.	If the temperature is high when use the soft-start, will cause the discharge MOS not work, and lead the entire soft-start circuit to be overheated.	Stop to riding the bike until the overheat protection unlocked.	
26	E26	000B0	Storage error.	It's caused by the faulty operation during the production.	Send the bike to the nearest dealer to repair.	
27	E27	000C0	Discharge fuse failure error.	Don't have this error for STING's battery. Just a default setting error.		
28	E28	000D0	Charge fuse failure error.	Don't have this error for STING's battery. Just a default setting error.		

ITEM	ERROR CODES (MX VERSION)	ERROR CODES (L1E VERSION)	DESCRIPTION	ERROR ANALYSIS	SOLUTIONS	REMARKS
29	E29	000E0	Level 3 over current error.	Short circuit in the external circuit causes this error.	Inspect and eliminate the short circuit.	If you don't have the professional tools, or you can find the short circuit, please send the bike to the nearest dealer to inspect and repair.
30	E30	000F0	Level 4 over current error.	Short circuit in the external circuit causes this error.	Inspect and eliminate the short circuit.	If you don't have the professional tools, or you can find the short circuit, please send the bike to the nearest dealer to inspect and repair.
31	E31	00100	Setting error.	It's caused by any improper operations during the production.	Send the bike to the nearest dealer to repair.	
32	E33	00300	Controller phase wire over current error.	Controller phase wire current is equal or greater than the protection value.	1. Turn off the bike, and switch off the circuit breaker. Then, check the whether the motor phase wire terminal got loose, or broken. And then, check whether the motor outlet phase sequence corresponds to the U / V / W on the controller. Finally, check whether the magnetic encoder output wire corresponds to the yellow, green and blue wires on the harness assy. 2. Check whether anything stuck the rear wheel.	If the solution cannot solve the error, please send the bike to the nearest dealer to inspect and repair.
33	E34	00400	Controller busbar over current error.	Controller busbar current is equal or greater than the protection value.	1. Turn off the bike, and switch off the circuit breaker. Then, check the whether the motor phase wire terminal got loose, or broken. And then, check whether the motor outlet phase sequence corresponds to the U / V / W on the controller. Finally, check whether the magnetic encoder output wire corresponds to the yellow, green and blue wires on the harness assy. 2. Check whether anything stuck the rear wheel.	If the solution cannot solve the error, please send the bike to the nearest dealer to inspect and repair.

ITEM	ERROR CODES (MX VERSION)	ERROR CODES (L1E VERSION)	DESCRIPTION	ERROR ANALYSIS	SOLUTIONS	REMARKS
34	E35	00500	Controller MOS error.	Controller MOS welding loose or MOS is broken.	Replace the controller assy.	
35	E36	00600	Tip-over sensor error.	Tip-over sensor got a poor contact, or tip-over sensor broken.	Turn off the bike, and stand the bike to be upright. Then, re-start the bike. The error will be eliminated.	If the solution cannot solve the error, please send the bike to the nearest dealer to inspect and repair.
36	E37	00700	Throttle error.	1. Throttle connection loose. 2. The throttle didn't return back to the proper position before start. 3. The throttle is broken.	1. Check the throttle connection is loose or broken. 2. Make sure the throttle return to the proper position before the start. 3. If the throttle connection is no problem, and throttle return to the proper position, still have the throttle error. Then, just replace a new throttle.	
37	E38	00800	Low battery protection error.	When the battery is low, the low battery protection will run automatically.	Charge the battery.	
38	E39	00900	Over voltage protection error	When the voltage of the battery is equal or greater than the protection value, the over voltage protection will run automatically.	Please use Talaria's stock charger to charge the battery.	If the solution cannot solve the error, please send the bike to the nearest dealer to inspect and repair.
39	E40	00A00	Magnetic encoder error.	Magnetic encoder got a poor contact or it's broken.	1. Check whether the magnetic encoder got a poor contact? If yes, repair it. 2. If the magnetic encoder is well contacted, it means it's broken. Please replace a new magnetic encoder.	If the solution cannot solve the error, please send the bike to the nearest dealer to inspect and repair.
40	E41	00B00	Motor phase wire failure error.	Motor phase wire loose or incorrect connection caused the error	Turn off the bike, and switch off the circuit breaker. Then, check the whether the motor phase wire terminal got loose, or broken. And then, check whether the motor outlet phase sequence corresponds to the U / V / W on the controller. Finally, check whether the magnetic encoder output wire corresponds to the yellow, green and blue wires on the harness assy.	If the solution cannot solve the error, please send the bike to the nearest dealer to inspect and repair.

ITEM	ERROR CODES (MX VERSION)	ERROR CODES (L1E VERSION)	DESCRIPTION	ERROR ANALYSIS	SOLUTIONS	REMARKS
41	E42	00C00	Motor overheat error.	Long time peak power riding will cause the motor to be overheated, or motor inner temperature sensor got a poor contact, or motor inner temperature sensor to be broken.	1. Stop riding until the motor's temperature return to normal. 2. Check whether the magnetic encoder is loose or broken. If it's broken, need to replace with new one.	
42	E43	00D00	Motor temperature sensor error.	Long time peak power riding will cause the motor to be overheated, or motor inner temperature sensor got a poor contact, or motor inner temperature sensor to be broken.	1. Stop riding until the motor's temperature return to normal. 2. Check whether the magnetic encoder is loose or broken. If it's broken, need to replace with new one.	
43	E44	00E00	Controller overheat error.	Long time peak power riding will cause the controller to be overheated	Stop riding until the controller return to the normal temperature.	If the solution cannot solve the error, please send the bike to the nearest dealer to inspect and repair.
44	E45	00F00	Controller temperature sensor error.	Long time peak power riding will cause the controller to be overheated, or controller temperature sensor got a poor contact, or controller temperature sensor to be broken.	Stop riding until the controller return to the normal temperature.	If the solution cannot solve the error, please send the bike to the nearest dealer to inspect and repair.
45	E46	01000	Current sensor error.	Current sensor failure.	Please send the bike to the nearest dealer to inspect and repair.	
46	E47	02000	Motor lack of phase error.	1. Circuit breaker is not switched on. 2. Motor phase wires (U/V/W) loose or incorrect connection.	1. Switch on the circuit breaker, and restart the bike. 2. Turn off the bike, and switch off the circuit breaker. Then, check the whether the motor phase wire terminal got loose, or broken. And then, check whether the motor outlet phase sequence corresponds to the U / V / W on the controller. Finally, check whether the magnetic encoder output wire corresponds to the yellow, green and blue wires on the harness assy.	If the solution cannot solve the error, please send the bike to the nearest dealer to inspect and repair.

ITEM	ERROR CODES (MX VERSION)	ERROR CODES (L1E VERSION)	DESCRIPTION	ERROR ANALYSIS	SOLUTIONS	REMARKS
47	E48	03000	Motor locked-rotor protection error.	During the riding, if the rear wheel is stuck, and cannot rotate, or the motor, gearbox, brake, chain are stuck, will cause the discharge current load to be equal or greater than the protection value. Then, cause the error.	<p>1. Turn off the bike, as well as to switch off the circuit breaker. Then, put the bike on a lifer, to check whether the rear wheel can rotate normally, if anything stuck the rear wheel, please eliminate it. And please also check whether there're things stuck the motor, gearbox, chain and brake. If yes, please eliminate it.</p> <p>2. Choose the right road condition to ride the bike.</p>	If the solution cannot solve the error, please send the bike to the nearest dealer to inspect and repair.
48	E49	04000	Communication Error.	CAN communication wire loose, fall off or hardware failure.	Turn off the bike, as well as to switch off the circuit breaker. Then, check the all the CAN connections on the bike to see whether there's the loose or breaks. (Dash connection, controller connection, battery pack communication connection. These 3 positions have CAN connections). If there's the loose or breaks, just repair them, and re-start the bike, the error will be solved.	If the solution cannot solve the error, please send the bike to the nearest dealer to inspect and repair.



CIRCUIT DIAGRAM

