

# Grundfos solar surface pump

Installation and operating instructions





# Grundfos solar surface pump

---

Pump end .....	4
Motor .....	18
Appendix .....	51

Original installation and operating instructions.

## CONTENTS

## 1. Pump end

	Page
<b>2. Limited warranty</b>	<b>4</b>
<b>3. Symbols used in this document</b>	<b>4</b>
<b>4. Introduction</b>	<b>5</b>
<b>5. Shipment inspection</b>	<b>5</b>
5.1 Lifting instructions	5
5.2 Ensure you have the right pump	5
5.3 Checking the condition of the pump	5
5.4 Electrical requirements	5
<b>6. Identification</b>	<b>6</b>
6.1 Nameplate data	6
6.2 Type keys	6
<b>7. Application</b>	<b>9</b>
<b>8. Operating conditions</b>	<b>9</b>
8.1 Liquid temperatures	9
8.2 Minimum inlet pressures	9
8.3 Maximum inlet pressures	9
8.4 Maximum operating pressures	9
<b>9. Installation</b>	<b>10</b>
9.1 Pump location	10
9.2 Foundation	10
9.3 Pump mounting	11
9.4 Suction pipe	11
9.5 Discharge pipe	11
9.6 Flange forces and torques	12
9.7 Minimum continuous duty flow rates [gpm (m <sup>3</sup> /hr)]	12
9.8 Check valves	12
9.9 Temperature rise	12
9.10 Electrical connection	12
9.11 Position of terminal box	13
9.12 Field wiring	13
<b>10. Commissioning and start-up</b>	<b>13</b>
10.1 Priming	13
10.2 Operating parameters	13
10.3 Frost protection	13
<b>11. Maintaining the pump</b>	<b>14</b>
<b>12. Maintaining the motor</b>	<b>14</b>
12.1 Motor inspection	14
<b>13. Replacing the motor</b>	<b>14</b>
13.1 Disassembly	14
13.2 Assembly	14
<b>14. Parts list</b>	<b>15</b>
14.1 Spare parts	15
<b>15. Diagnosing specific problems</b>	<b>16</b>

## 2. Limited warranty

Products manufactured by GRUNDFOS PUMPS CORPORATION (Grundfos) are warranted to the original user only to be free of defects in material and workmanship for a period of 24 months from date of installation, but not more than 30 months from date of manufacture. Grundfos' liability under this warranty shall be limited to repairing or replacing at Grundfos' option, without charge, F.O.B. Grundfos' factory or authorized service station, any product of Grundfos' manufacture. Grundfos will not be liable for any costs of removal, installation, transportation, or any other charges which may arise in connection with a warranty claim. Products which are sold but not manufactured by Grundfos are subject to the warranty provided by the manufacturer of said products and not by Grundfos' warranty. Grundfos will not be liable for damage or wear to products caused by abnormal operating conditions, accident, abuse, misuse, unauthorized alteration or repair, or if the product was not installed in accordance with Grundfos' printed installation and operating instructions.

To obtain service under this warranty, the defective product must be returned to the distributor or dealer of Grundfos' products from which it was purchased together with proof of purchase and installation date, failure date, and supporting installation data. Unless otherwise provided, the distributor or dealer will contact Grundfos or an authorized service station for instructions. Any defective product to be returned to Grundfos or a service station must be sent freight prepaid; documentation supporting the warranty claim and/or a Return Material Authorization must be included if so instructed.

GRUNDFOS WILL NOT BE LIABLE FOR ANY INCIDENTAL OR CONSEQUENTIAL DAMAGES, LOSSES, OR EXPENSES ARISING FROM INSTALLATION, USE, OR ANY OTHER CAUSES. THERE ARE NO EXPRESS OR IMPLIED WARRANTIES, INCLUDING MERCHANTABILITY OR FITNESS FOR A PARTICULAR PURPOSE, WHICH EXTEND BEYOND THOSE WARRANTIES DESCRIBED OR REFERRED TO ABOVE.

Some jurisdictions do not allow the exclusion or limitation of incidental or consequential damages and some jurisdictions do not allow limit actions on how long implied warranties may last. Therefore, the above limitations or exclusions may not apply to you. This warranty gives you specific legal rights and you may also have other rights which vary from jurisdiction to jurisdiction.

## 3. Symbols used in this document

**Warning**

*If these safety instructions are not observed, it may result in personal injury.*

**Warning**

*If these instructions are not observed, it may lead to electric shock with consequent risk of serious personal injury or death.*

**Caution**

*If these safety instructions are not observed, it may result in malfunction or damage to the equipment.*

**Note**

*Notes or instructions that make the job easier and ensure safe operation.*

## 4. Introduction



### Warning

**Prior to installation, read these installation and operating instructions. Installation and operation must comply with local regulations and accepted codes of good practice.**

The CR range is based on the inline multistage centrifugal pump first pioneered by Grundfos. CR is available in four basic materials and over one million configurations. CR is suitable for pumping water and water-like liquids in industry, petrochemical, water treatment, commercial buildings, and many other applications. Some of the outstanding characteristics of CR are:

- superior efficiency
- reliability
- easy maintenance
- compact size and small footprint
- quiet operation.

## 5. Shipment inspection

Examine the components carefully to make sure no damage has occurred to the pump during shipment. Care should be taken to ensure the pump is NOT dropped or mishandled.

### 5.1 Lifting instructions

#### Caution

**Do not use the lifting eyes of the motor for lifting the entire pump and motor assembly.**

Lift pump assembly with lifting straps that pass through the motor stool. Ensure that the load is not applied to the pump shaft.

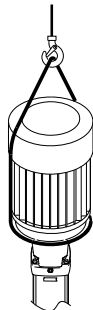

Fig. 1 Correct lifting of a CR pump

### 5.2 Ensure you have the right pump

Check the pump nameplate to make sure that it is the one you ordered.

- **CR:** Centrifugal pump with standard cast iron and AISI 304 stainless steel construction
- **CRI:** Centrifugal pump; all parts in contact with the pumped liquid are AISI 304 stainless steel
- **CRN:** Centrifugal pump; all parts in contact with the pumped liquid are AISI 316 stainless steel

### 5.3 Checking the condition of the pump

The packing in which your pump arrived is specially designed for your pump to prevent damage during shipment. As a precaution, leave the pump in the packing until you are ready to install it. Examine the pump for any damage that may have occurred during shipping. Examine any other parts of the shipment as well for any visible damage.

#### Note

**If the shipment consists of a complete unit (motor attached to pump end), the position of the coupling connecting the pump shaft to the motor shaft is set to factory specifications. No adjustment is required. If the shipment is a pump end without motor, follow the adjustment procedures in section 13. Replacing the motor.**

### Pump without motor (CR, CRI, CRN 1s, 1, 3, 5, 10, 15, and 20 only):

If you purchased a pump end without motor, the shaft seal has been set from factory. Do not loosen the three set screws on the shaft seal when attaching the motor.

## 5.4 Electrical requirements



### Warning

**Electrical work: All electrical work should be performed by a qualified electrician in accordance with the current national, state, and local codes and regulations.**

### Warning

**Shock hazard: A faulty motor or faulty wiring can cause electric shock that could be fatal, whether the motor is touched directly or the current is conducted through standing water. For this reason, safe installation and operation require proper grounding of the pump to the power supply ground (earth) terminal.**



**In all installations, connect the above-ground metal plumbing to the power supply ground terminal as described in Article 250-80 of the National Electrical Code.**

Verify the power supply to make sure that the voltage, phases and frequency match those of the pump. The proper operating voltage and other electrical information appear on the motor nameplate. These motors are designed to run on - 10 %/+ 10 % of the rated nameplate voltage. For dual-voltage motors, the motor should be internally connected to operate on the voltage closest to the 10 % rating, i.e., a 208V motor should be wired according to the 208V wiring diagram. The wiring diagram can be found on either a plate attached to the motor or on a label inside the terminal box cover.

#### Caution

**Do not operate the pump if voltage variations are greater than - 10 %/+ 10 %.**

TM04 0339 0608

## 6. Identification

### 6.1 Nameplate data

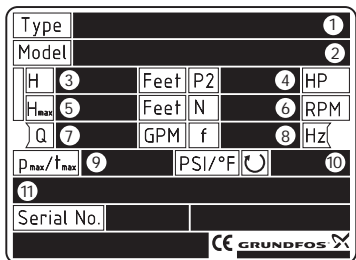

Fig. 1 Example of nameplate CR, CRI, CRN, CRT

Pos.	Description
1	Type designation
2	Model, material number, production number
3	Head in feet at rated flow
4	Rated motor Hp
5	Head at zero flow
6	Rated rpm
7	Rated flow
8	Rated frequency
9	Maximum pressure and maximum liquid temperature
10	Direction of rotation
11	Production country

Specification of the model line in nameplates:

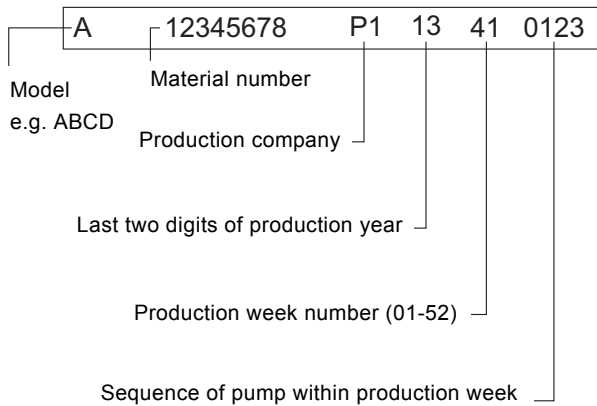

Fig. 2 Key to model line in nameplates

### 6.2 Type keys

#### Type key

CR, CRI, CRN 1s, 1, 3, 5, 10, 15, and 20

#### Example

Type range: **CR 3 -10 A FGJ A E HQQE**

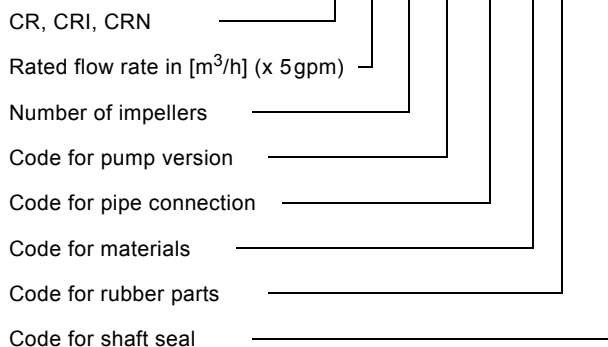

TM04 3895 2609

TM04 3904 3913

**6.2.1 Codes**

Example	A	-G	-A	-E	-H	QQ	E
<b>Pump version</b>							
A	Basic version						
B	Oversize motor						
E	Certificate/approval						
F	CR pump for high temperatures (air-cooled top assembly)						
H	Horizontal version						
HS	High-pressure pump with high speed MLE motor						
I	Different pressure rating						
J	Pump with different max speed						
K	Pump with low NPSH						
M	Magnetic drive						
N	Fitted with sensor						
P	Undersize motor						
R	Horizontal version with bearing bracket						
SF	High pressure pump						
T	Over size motor (two flange sizes bigger)						
X	**Special version						
<b>Pipe connection</b>							
A	Oval flange Rp thread						
B	Oval flange NPT thread						
CA	FlexiClamp (CRI(E), CRN(E) 1, 3, 5, 10, 15, 20)						
CX	Triclamp (CRI(E), CRN(E) 1, 3, 5, 10, 15, 20)						
F	DIN flange						
G	ANSI flange						
J	JIS flange						
N	Changed diameter of ports						
P	PJE coupling						
X	Special version						
<b>Materials</b>							
A	Basic version						
D	Carbon-graphite filled PTFE (bearings)						
G	Wetted parts AISI 316						
GI	All parts stainless steel, wetted parts AISI 316						
I	Wetted parts AISI 304						
II	All parts stainless steel, wetted parts AISI 304						
K	Bronze (bearings)						
S	SiC bearings + PTFE neck rings						
X	Special version						
<b>Code for rubber parts</b>							
E	EPDM						
F	FXM						
K	FFKM						
V	FKM						

Example	A	-G	-A	-E	-H	QQ	E
<b>Shaft seal</b>							
A	O-ring seal with fixed driver						
B	Rubber bellows seal						
E	Cartridge seal with O-ring						
H	Balanced cartridge seal with O-ring						
K	Metal bellows cartridge seal						
O	Double seal, back-to-back						
P	Double seal, tandem						
X	Special version						
B	Carbon, synthetic resin-impregnated						
H	Cemented tungsten carbide, embedded (hybrid)						
Q	Silicon carbide						
U	Cemented tungsten carbide						
X	Other ceramics						
E	EPDM						
F	FXM						
K	FFKM						
V	FKM						

\*\* If a pump incorporates more than two pump versions, the code for the pump version is X. X also indicates special pump versions not.



## 7. Application

Compare the pump's nameplate data or its performance curve with the application in which you plan to install it. Make sure the application falls within the following limits.

Type	Application/liquid
CR	Hot and chilled water, boiler feed, condensate return, glycols and solar thermal liquids.
CRI/CRN	Deionized, demineralized and distilled water. Brackish water and other liquids unsuitable for contact with iron or copper alloys. (Consult manufacturer for specific liquid compatibilities.)

## 8. Operating conditions

### 8.1 Liquid temperatures

Pump	Liquid temperature
CR, CRI, CRN 1s, 3, 5, 10, 15, and 20	-4 to +248 °F (-20 to +120 °C)

All motors are designed for continuous duty in +104 °F (+40 °C) ambient air conditions. For higher ambient temperature conditions, consult Grundfos.

### 8.2 Minimum inlet pressures

All CR, CRI, CRN	NPSHR + 2 feet (0.6 m)
------------------	------------------------

### 8.3 Maximum inlet pressures

Pump type	Stages		Max. [psi (bar)]
	60 Hz	50 Hz	
CR, CRI, CRN 1	2 to 36	2 to 36	145 (10)
	27		217 (15)
CR, CRI, CRN 3	2 to 15	2 to 29	145 (10)
	17 to 25	31 to 36	217 (15)
CR, CRI, CRN 5	2 to 9	3 to 16	145 (10)
	10 to 24	18 to 36	217 (15)
CR, CRI, CRN 10	1 to 5	1 to 6	116 (8)
	6 to 18	7 to 22	145 (10)
CR, CRI, CRN 15	1 to 2	1 to 3	116 (8)
	3 to 12	4 to 17	145 (10)

## 8.4 Maximum operating pressures

at +248 °F (120 °C)

Pump type/ connection	Stages		Max. [psi (bar)]
	60 Hz	50 Hz	
<b>CR, CRI, CRN 1</b>			
Oval flange	1 to 17	1 to 23	232 (16)
FGJ, PJE	1 to 27	1 to 36	362 (25)
<b>CR, CRI, CRN 3</b>			
Oval flange	1 to 17	1 to 23	232 (16)
FGJ, PJE	1 to 27	1 to 36	362 (25)
<b>CR, CRI, CRN 5</b>			
Oval flange	1 to 16	1 to 22	232 (16)
FGJ, PJE	1 to 24	1 to 36	362 (25)
<b>CR, CRI 10</b>			
Oval flange CR	1 to 6		145 (10)
Oval flange, CRI	1 to 10	1 to 16	232 (16)
FGJ, GJ, PJE	1 to 10	1 to 16	232 (16)
FGJ, GJ, PJE	12 to 17	17 to 22	362 (25)
<b>CRN 10</b>			
All	1 to 17	1 to 22	362 (25)
<b>CR, CRI 15</b>			
Oval flange	1 to 5	1 to 7	145 (10)
FGJ, GJ, PJE	1 to 8	1 to 10	232 (16)
FGJ, GJ, PJE	9 to 12	12 to 17	362 (25)
<b>CRN 15</b>			
All	1 to 12	1 to 17	362 (25)

Consult Grundfos in case of other operating conditions.

## 9. Installation



**Warning**  
Do not turn on the power supply until the pump is properly installed.

### 9.1 Pump location

Locate the pump in a dry, well-ventilated, frost-free area which is not subject to extreme variation in temperature.

Make sure the pump is mounted at least 6" (150 mm) clear of any obstruction or hot surfaces.

The motor requires an adequate air supply to prevent overheating and adequate vertical space to remove the motor for repair.

In open systems requiring suction lift, locate the pump as close to the liquid source as possible to reduce friction loss in pipes.

### 9.2 Foundation

Use concrete or similar foundation material to provide a secure, stable mounting base for the pump.

See table below for bolt hole center line dimensions for the various pump types.

Secure the pump to the foundation using all four bolts and shim pump base to assure the pump is vertical and all four pads on the base are properly supported (uneven surfaces can result in pump base breakage when mounting bolts are tightened).

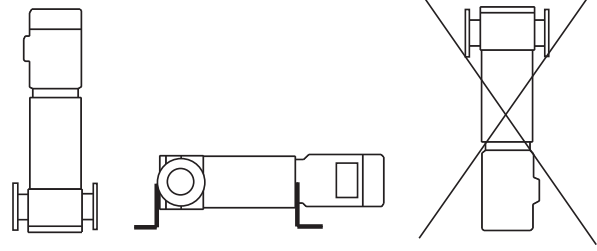

**Fig. 3** Pump position

The pump can be installed vertically or horizontally. See fig. 3. Ensure that an adequate supply of cool air reaches the motor cooling fan. The motor must never fall below the horizontal plane. Arrows on the pump base show the direction of flow of liquid through the pump.

To minimize possible noise from the pump, it is advisable to fit expansion joints on either side of the pump and anti-vibration mountings between the foundation and the pump.

**Note** *Make sure the vent plug is located in the uppermost position.*

Fit isolating valves on either side of the pump to avoid draining the system if the pump needs to be cleaned, repaired or replaced.

TM04 3906 0409

### Base and bolt hole center line dimensions

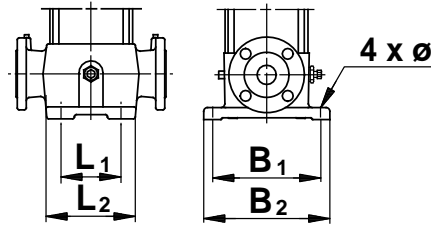

TM00 2256 3393

Pump type	L1		L2		B1		B2		Ø	
	[inches]	[mm]	[inches]	[mm]	[inches]	[mm]	[inches]	[mm]	[inches]	[mm]
CR 1s, 1, 3, 5	3.94	100	5.69	145	7.06	180	8.69	220	0.5	13
CRI, CRN 1s 1, 3, 5	3.94	100	5.88	150	7.06	180	8.69	220	0.5	13
CR 10, 15	5.13	130	6.94	176	8.44	215	10.06	256	0.56	13.5
CRN 10, 15	5.13	130	7.88	200	8.44	215	9.75	248	0.5	13

### 9.3 Pump mounting



**Warning**  
**CR, CRI, CRN pumps are shipped with covered suction and discharge ports. Remove the covers before the pipes are connected to the pump.**

#### 9.3.1 Recommended installation torques

Pump type	Recommended foundation torque		Recommended flange torque	
	[ft-lbs]	[Nm]	[ft-lbs]	[Nm]
CR, CRI, CRN 1s/1/3/5	30	40	37-44	50-60
CR, CRI, CRN 10/15	37	50	44-52	60-70

### 9.4 Suction pipe

The suction pipe should be adequately sized and run as straight and short as possible to keep friction losses to a minimum (minimum of four pipe diameters straight run prior to the suction flange). Avoid using unnecessary fittings, valves or accessory items. Use butterfly or gate valves in the suction line only when it is necessary to isolate a pump because of a flooded suction condition. This would occur if the water source is above the pump. See fig. 4 and fig. 5. Flush piping prior to pump installation to remove loose debris.

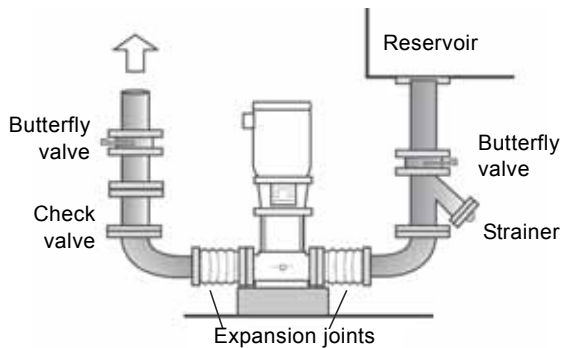

TMO5 9273 3613

**Fig. 4** Flooded suction

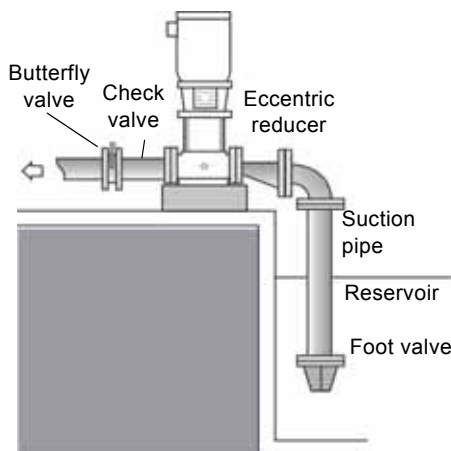

TMO5 9274 3613

**Fig. 5** Suction lift\*

\* The suction pipe should have a fitting on it for priming.

### 9.4.1 Suction pipe sizes

The following recommended suction pipe sizes are the smallest sizes which should be used with any specific CR pump type. The suction pipe size should be verified with each installation to ensure good pipe practices are being observed and excess friction losses are not encountered. High temperatures may require larger diameter pipes to reduce friction and improve NPHSA.

Pump type	Min. suction pipe size		
	[inch]	[mm]	
CR, CRI, CRN 1s, 1, 3	1	25	Nominal diameter acc. to ANSI schedule 40
CR, CRI, CRN 5	1.25	32	Nominal diameter acc. to ANSI schedule 40
CR, CRI, CRN 10, 15	2	50	Nominal diameter acc. to ANSI schedule 40

### 9.5 Discharge pipe

We suggest to install a check valve and an isolating valve in the discharge pipe. Pipe, valves and fittings should be at least the same diameter as the discharge pipe or sized in accordance with good piping practices to reduce excessive liquid velocities and friction losses in pipes.

**Caution** *The pressure rating of pipes, valves and fittings must be equal to or greater than the maximum system pressure.*

Before installing the pump, pressure check the discharge piping to at least the maximum pressure the pump is capable of generating or as required by codes or local regulations.

Whenever possible, avoid high pressure loss fittings, such as elbows or branch tees directly on either side of the pump. The piping should be adequately supported to reduce thermal and mechanical stresses on the pump.

According to good installation practices, clean the system thoroughly and flush it of all foreign materials and sediment prior to pump installation. Furthermore, never install the pump at the lowest point of the system due to the natural accumulation of dirt and sediment. If there is excessive sediment or suspended particles, we recommend that a strainer or filter is used. Grundfos recommends that pressure gauges are installed on suction and discharge flanges or in pipes to monitor pump and system performance.

### 9.6 Flange forces and torques

If not all loads reach the maximum permissible value stated in the tables after fig. 6, one of these values may exceed the normal limit. Contact Grundfos for further information.

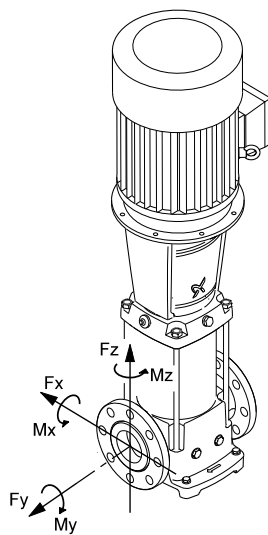

Y-direction: Direction of chamber stack  
 Z-direction: 90 ° from inlet/outlet  
 X-direction: Inlet/outlet

TM04 0346 1613

Fig. 6 Flange forces and torques

Flange	CR, CRI, CRN	Force [F]					
		Y-direction		Z-direction		X-direction	
		[lb]	[N]	[lb]	[N]	[lb]	[N]
1.25" (32 mm)	1s to 5	171	760	263	1170	175	778
2.00" (50 mm)	10, 15	303	1348	371	1650	337	1499

Flange	CR, CRI, CRN	Torque [M]					
		Y-direction		Z-direction		X-direction	
		[lb-ft]	[Nm]	[lb-ft]	[Nm]	[lb-ft]	[Nm]
1.25" (32 mm)	1s to 5	605	820	715	969	900	1220
2.00" (50 mm)	10, 15	738	1001	848	1150	1,033	1401

### 9.7 Minimum continuous duty flow rates [gpm (m<sup>3</sup>/hr)]

Pump type	min. °F to			
	176 °F (min. °C to 80 °C)	at 210 °F (at 99 °C)	at 248 °F (at 120 °C)	at 356 °F (at 180 °C)
CR, CRI, CRN 1s	0.5 (0.11)	0.7 (0.16)	1.2 (0.27)	1.2 (0.27)
CR, CRI, CRN 1	0.9 (0.2)	1.3 (0.3)	2.3 (0.52)	2.3 (0.52)
CR, CRI, CRN 3	1.6 (0.36)	2.4 (0.55)	4 (0.91)	4 (0.91)
CR, CRI, CRN 5	3 (0.68)	4.5 (1.02)	7.5 (1.7)	7.5 (1.7)
CR, CRI, CRN 10	5.5 (1.25)	8.3 (1.89)	14 (3.18)	14 (3.18)
CR, CRI, CRN 15	9.5 (2.16)	14 (3.18)	24 (5.45)	24 (5.45)

### 9.8 Check valves

A check valve may be required on the discharge side of the pump to prevent the pump's inlet pressure from being exceeded.

When a pump with no check valve is stopped because there is no demand on the system (all valves are closed), the high system pressure on the discharge side of the pump will "find" its way back to the inlet of the pump.

### 9.9 Temperature rise

It may sometimes be necessary to stop the flow through a pump during operation.

When the flow is stopped, the power to the pump is transferred to the pumped liquid as head, causing a temperature rise in the liquid.

The result is risk of overheating and consequent damage to the pump. The risk depends on the temperature of the pumped liquid and for how long the pump is operating without flow. See the following temperature rise table.

Pump type	Time for temperature rise of 18 °F (10 °C)	
	Seconds	Minutes
CR 1s, 1, 3	210	3.5
CR 5	240	4.0
CR 10	210	3.5
CR 15	150	2.5

### Conditions/reservations

The listed times are subject to the following conditions/reservations:

- No exchange of heat with the surroundings.
- The pumped liquid is water with a specific heat capacity of 1.0 Btu/lb. °F (4.18 kJ/kg °C).
- Pump parts (chambers, impellers and shaft) have the same heat capacity as water.
- The water in the base and the pump head is not included.

These reservations should give sufficient safety margin against excessive temperature rise.

The maximum temperature must not exceed the pump maximum temperature rating.

### 9.10 Electrical connection

#### Warning

*The safe operation of this pump requires that it is grounded in accordance with the National Electrical Code and local codes and regulations. Connect the ground conductor to the grounding screw in the terminal box and then to the ACCEPTABLE grounding point. All electrical work must be performed by a qualified electrician in accordance with the latest edition of the National Electrical Code and local codes and regulations.*



### 9.11 Position of terminal box

The motor terminal box can be turned to any of four positions in steps of 90°.

To rotate the terminal box, remove the four bolts securing the motor to the pump but do not remove the coupling. Turn the motor to the desired position; replace and securely tighten the four bolts. See fig. 7.

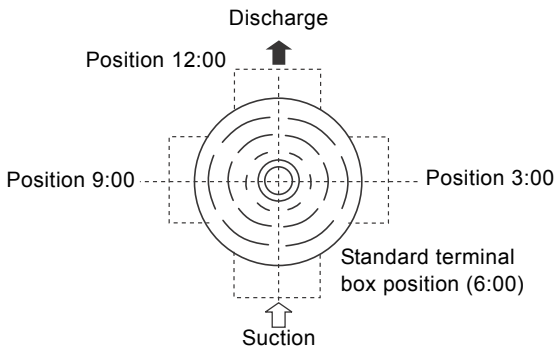

Fig. 7 Motor terminal box positions (top view)

### 9.12 Field wiring

Lead sizes should be based on the current carrying properties of conductors required by the latest edition of the National Electrical Code or local regulations.

## 10. Commissioning and start-up

### 10.1 Priming

To prime the pump in a closed system or an open system where the water source is above the pump, close the pump isolating valve(s) and open the priming plug on the pump head. See fig. 8, fig. 8, and fig. 9.

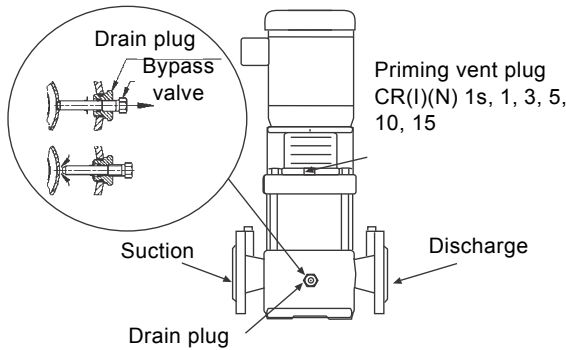

Fig. 8 Position of plugs and valve

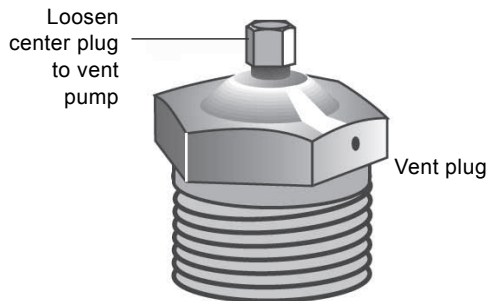

Fig. 9 Vent plug

Gradually open the isolating valve in the suction line until a steady stream of airless water runs out of the priming hole. Close the plug and tighten securely. Completely open the isolating valves.

In open systems where the water level is below the pump inlet, the suction pipe and pump must be filled with liquid and vented before starting the pump. Close the discharge isolating valve and remove the priming plug. Pour water through the priming hole until the suction pipe and pump are completely filled with liquid. If the suction pipe does not slope downwards away from the pump, the air must be purged while priming the pump. Replace the priming plug and tighten securely.

Follow these steps:

1. Switch off the power supply.
2. Check to make sure the pump has been filled and vented.
3. Remove the coupling guard and rotate the pump shaft by hand to make sure it turns freely.
4. Verify that the electrical connections are in accordance with the wiring diagram on the motor.

**For CR, CRI, CRN 1s to 5 it is advisable to open the bypass valve during start-up. See fig. 8.**

**Note**

**The bypass valve connects the suction and discharge sides of the pump, thus making the filling procedure easier. Close the bypass valve when operation is stable.**

**Motors should not be run unloaded or uncoupled from the pump at any time; damage to the motor bearings will occur.**

**Caution**

**Do not start the pump before priming or venting the pump. See fig. 15. Never let the pump run dry.**

### 10.2 Operating parameters

CR multi-stage centrifugal pumps installed in accordance with these instructions and sized for correct performance will operate efficiently and provide years of service. The pumps are water-lubricated and do not require any external lubrication or inspection. The motors may require periodic lubrication as described in section 12. *Maintaining the motor.*

Under no circumstances should the pump be operated for any prolonged periods of time without flow through the pump. This can result in motor and pump damage due to overheating. A properly sized relief valve should be installed to allow sufficient liquid to circulate through the pump to provide adequate cooling and lubrication of the pump bearings and seals.

### 10.3 Frost protection

If the pump is installed in an area where frost could occur, the pump and system should be drained during freezing temperatures to avoid damage. To drain the pump, close the isolating valves, remove the priming plug and drain plug at the base of the pump. Do not replace the plugs until the pump is to be used again. Always replace the drain plug with the original or an exact replacement. Do not replace with a standard plug. Internal recirculation will occur, reducing the output pressure and flow.

TM04 3923 0409

TM04 3922 3613

TM04 3920 3613

## 11. Maintaining the pump

Depending on the conditions and operating time, make the following checks at regular intervals:

- Check that the pump meets the required performance and is operating smoothly and quietly.
- Check that there are no leaks, particularly at the shaft seal.
- Check that the motor is not overheating.
- Remove and clean all strainers or filters in the system.
- Check that the tripping function of the motor overload protection works.
- Check the operation of all controls.
- If the pump is not operated for unusually long periods, maintain the pump in accordance with these instructions. In addition, if the pump is not drained, the pump shaft should be manually rotated or run for short periods of time at monthly intervals.
- In severe duty applications, pump life may be extended by performing one of the following actions:
  - Drain the pump after each use.
  - Flush the pump with water or other liquid that is compatible with the pump materials and process liquid.
  - Disassemble the pump and thoroughly rinse or wash components in contact with the pumped liquid with water or other liquid that is compatible with the pump materials and process liquid.

If the pump fails to operate or there is a loss of performance, see to *section 15. Diagnosing specific problems*.

## 12. Maintaining the motor

### Warning



**Before starting work on the motor, make sure that all power supplies to the motor have been switched off and that they cannot be accidentally switched on. Electric shock can cause serious or fatal injury. Only qualified personnel should attempt installation, operation, and maintenance of this equipment.**

### 12.1 Motor inspection

Inspect the motor approximately every 500 hours of operation or every three months, whichever occurs first. Keep the motor clean and the ventilation openings clear.

Go through the following steps during each inspection:

1. Check that the motor is clean. Check that the interior and exterior of the motor are free of dirt, oil, grease, water, etc. Oily residue, paper, pulp, textile lint, etc. can accumulate and block motor ventilation. If the motor is not properly ventilated, overheating can occur and cause early motor failure.
2. Check all electrical connections to be sure that they are tightened securely.

## 13. Replacing the motor

**Motors used on CR pumps are specifically selected to our rigid specifications.**

**Replacement motors must be of the same frame size, should be equipped with the same or better bearings and have the same service factor. Failure to follow these recommendations may result in premature motor failure.**

### Caution

If the motor is damaged due to bearing failure, burning or electrical failure, observe the following instructions as to how to remove the motor and how to mount the replacement motor.



### Warning

**Before starting work on the motor, make sure that the mains switch has been switched off. It must be ensured that the power supply cannot be accidentally switched on.**

### 13.1 Disassembly

Proceed as follows:

1. Disconnect the power supply leads from the motor. Remove the coupling guards.

### Note

**For CR 1, 3, 5, 10, 15: Do not loosen the three hexagon socket head cap screws securing the shaft seal.**

2. Use the proper metric hexagon key to loosen the four cap screws in the coupling. Remove coupling halves completely.
3. Use the correct size spanner to loosen and remove the four mounting bolts joining motor and pump.
4. Lift the motor straight up until the shaft has cleared the motor stool.

### 13.2 Assembly

Proceed as follows:

1. Remove key from motor shaft, if present, and discard.
2. Thoroughly clean the surfaces of the motor and pump mounting flanges. The motor and shaft must be clean of all oil or grease and other contaminants where the coupling attaches. Place the motor on top of the pump.
3. Turn the terminal box to the desired position by rotating the motor.
4. Insert the four mounting bolts, then tighten diagonally and evenly:
  - for 0.38" (10 mm) bolts (1/2 - 2 hp), torque = 17 ft-lb (23 Nm)
  - for 0.50" (13 mm) bolts (3-40 hp), torque = 30 ft-lb (41 Nm)
  - for 0.63" (16 mm) bolts (50-100 hp), torque = 59 ft-lb (80 Nm)
  - follow instructions for particular pump model in sections 13.2.2 CR 1s, 1, 3, and 5.

### 13.2.1 Torque specifications

Torque specifications CR, CRI, CRN 1s, 1, 3, 5, 10, 15, and 20 CRT 2, 4, 8, and 16		
Coupling screw size	Minimum torque	
	[ft-lb]	[Nm]
M6	10	14
M8	23	31
M10	46	62

### 13.2.2 CR 1s, 1, 3, and 5

1. Insert shaft pin into shaft hole.
2. Mount the coupling halves onto shaft and shaft pin.
3. Fit the coupling screws and leave loose. Check that the gaps on either side of the coupling are even and that the motor shaft keyway is centered in the coupling half as shown in fig. 6.
4. Tighten the screws to the correct torque. See section *13.2.1 Torque specifications*.

### 13.2.3 CR 10, 15

1. Insert shaft pin into shaft hole.
2. Insert plastic shaft seal spacer beneath shaft seal collar.
3. Mount the coupling halves onto shaft and shaft pin.
4. Fit the coupling screws and leave loose. Check that the gaps on either side of the coupling are even.
5. Tighten the screws to the correct torque. See section *13.2.1 Torque specifications*.
6. Remove plastic shaft seal spacer and hang it on inside of coupling guard.

## 14. Parts list

Grundfos offers an extensive parts list for each CR pump model. A parts list typically covers the following items:

- a diagram of pump parts which we recommend to have on hand for future maintenance
- a list of prepacked service kits covering the pump components most likely to be exposed to wear over time
- complete impeller stacks needed to replace the rotating assembly of each model.

These parts lists are available separately from the Grundfos literature warehouse or as a set with extensive service instructions in the Grundfos CR Service Manuals.



Fig. 10 Prepacked impeller stack kits



Fig. 11 Prepacked flange kits

### 14.1 Spare parts

Grundfos offers an extensive list of spare parts. For a current list of these parts, see Grundfos All Product Spare Parts/Service Kits Price List, part number L-SK-SL-002.

TM05 9272 3613

TM04 3916 1609

## 15. Diagnosing specific problems



### Warning

Before removing the terminal box cover and before removing/dismantling the pump, make sure that the power supply has been switched off and that it cannot be accidentally switched on.

Problem	Possible cause	Remedy
1. The pump does not run.	a) No power at motor.	Check voltage at motor terminal box. If no voltage at motor, check feeder panel for tripped circuits and reset circuit.
	b) Fuses are blown or circuit breakers are tripped.	Turn off power and remove fuses. Check for continuity with ohmmeter. Replace blown fuses or reset circuit breaker. If new fuses blow or circuit breaker trips, the electrical installation, motor and wires must be checked.
	c) Defective controls.	Check all safety and pressure switches for operation. Inspect contacts in control devices. Replace worn or defective parts or controls.
	d) Motor is defective.	Turn off power and disconnect wiring. Measure the lead to lead resistances with ohmmeter (RX-1). Measure lead to ground values with ohmmeter (RX-100K). Record measured values. If an open or grounded winding is found, remove motor and repair or replace.
	e) Pump is bound.	Turn off power and manually rotate pump shaft. If shaft does not rotate easily, check coupling setting and adjust as necessary. If shaft rotation is still tight, remove pump and inspect. Disassemble and repair.
2. The pump runs but at reduced capacity or does not deliver water.	a) Wrong rotation.	Check wiring for proper connections. Correct wiring.
	b) Pump is not primed or is airbound.	Turn pump off, close isolation valve(s), remove priming plug. Check fluid level. Refill the pump, replace plug and start the pump. Long suction lines must be filled before starting the pump.
	c) Strainers, check or foot valves are clogged.	Remove strainer, screen or valve and inspect. Clean and replace. Reprime pump.
	d) Suction lift too large.	Install compound pressure gauge at the suction side of the pump. Start pump and compare reading to performance data. Reduce suction lift by lowering pump, increase suction line size or removing high friction loss devices.
	e) Suction and/or discharge piping leaks.	Pump spins backwards when turned off. Air in suction pipe. Suction pipe, valves and fittings must be airtight. Repair any leaks and retighten all loose fittings.
	f) Pump worn.	Install pressure gauge, start pump, gradually close the discharge valve and read pressure at shutoff. Convert measured pressure (in psi) to head (in feet): (Measured psi x 2.31 ft/psi = ___ ft). Refer to the specific pump curve for shutoff head for that pump model. If head is close to curve, pump is probably OK. If not, remove pump and inspect.
	g) Pump impeller or guide vane is clogged.	Disassemble and inspect pump passageways. Remove any foreign materials found.
	h) Incorrect drain plug is installed.	If the proper drain plug is replaced with a standard plug, water will recirculate internally. Replace with proper plug.
	i) Improper coupling setting.	Check/reset the coupling; see page 18.



Problem	Possible cause	Remedy
3. Pump cycles too much	a) Pressure switch is not properly adjusted or is defective.	Check pressure setting on switch and operation. Check voltage across closed contacts. Readjust switch or replace if defective.
	b) Level control is not properly adjusted or is defective.	Check setting and operation. Readjust setting (refer to level control manufacturer's data). Replace if defective.
	c) Insufficient air charging or leaking tank or piping.	Pump air into tank or diaphragm chamber. Check diaphragm for leak. Check tank and piping for leaks with soap and water solution. Check air to water volume. Repair as necessary.
	d) Tank is too small.	Check tank size and air volume in tank. Tank volume should be approximately 10 gallons for each gpm of pump capacity. The normal air volume is 2/3 of the total tank volume at the pump cut-in pressure. Replace tank with one of correct size.
	e) Pump is oversized.	Install pressure gauges on or near pump suction and discharge ports. Start and run pump under normal conditions, record gauge readings. Convert psi to feet (Measured psi x 2.31 ft/psi = ____ ft) Refer to the specific pump curve for that model, ensure that total head is sufficient to limit pump delivery within its design flow range. Throttle pump discharge flow if necessary.
4. Fuses blow or circuit breakers or overload relays trip	a) Motor overloads are set too low.	Cycle pump and measure amperage. Increase heater size or adjust trip setting to a maximum of motor nameplate (full load) current.
	b) Motor is shorted or grounded.	Turn off power and disconnect wiring. Measure the lead-to-lead resistance with an ohmmeter (RX-1). Measure lead-to-ground values with an ohmmeter (RX-100K) or a megohm meter. Record values. If an open or grounded winding is found, remove the motor, repair and/or replace.
	c) Wiring or connections are faulty.	Check proper wiring and loose terminals. Tighten loose terminals. Replace damaged wire.
	d) Pump is bound.	Turn off power and manually rotate pump shaft. If shaft does not rotate easily, check coupling setting and adjust as necessary. If shaft rotation is still tight, remove pump and inspect. Disassemble and repair.

## 16. Motor

<b>17. Symbols used in this document</b>	<b>18</b>
<b>18. Abbreviations and definitions</b>	<b>18</b>
<b>19. General description</b>	<b>19</b>
19.1 Radio communication	19
19.2 Battery	19
<b>20. Identification</b>	<b>19</b>
20.1 Nameplate	20
20.2 Type key	21
<b>21. Mechanical installation</b>	<b>21</b>
21.1 Handling	21
21.2 Mounting	21
21.3 Cable entries	21
21.4 Ensuring motor cooling	21
21.5 Outdoor installation	22
21.6 Drain holes	22
<b>22. Electrical installation</b>	<b>22</b>
22.1 Protection against electric shock, indirect contact	22
22.2 Cable requirements	22
22.3 Power supply	23
22.4 Additional protection	23
22.5 Functional modules	23
<b>23. Basic CRFlex control connections</b>	<b>24</b>
23.1 Signal cables	27
23.2 Bus connection cable	27
<b>24. Operating conditions</b>	<b>27</b>
24.1 Maximum number of starts and stops	27
24.2 Ambient temperature	27
24.3 Installation altitude	27
24.4 Air humidity	28
24.5 Motor cooling	28
<b>25. Operating and control modes</b>	<b>28</b>
25.1 Overview	28
25.2 Operating mode	28
<b>26. User interfaces</b>	<b>28</b>
26.1 Standard control panel	29
26.2 Changing the position of the control panel	30
26.3 R100 remote control	31
26.4 Grundfos GO Remote	42
<b>27. Bus signal</b>	<b>44</b>
<b>28. Priority of settings</b>	<b>44</b>
<b>29. External setpoint signal</b>	<b>45</b>
29.1 Operation with sensor feedback	45
29.2 Constant-curve operation	46
<b>30. Grundfos Eye</b>	<b>47</b>
<b>31. Signal relays</b>	<b>48</b>
<b>32. Megging</b>	<b>49</b>
<b>33. Technical data, single-phase motors</b>	<b>49</b>
33.1 Supply voltage	49
33.2 Leakage current	49
<b>34. Inputs/outputs</b>	<b>49</b>
<b>35. Other technical data</b>	<b>50</b>
35.1 Sound pressure level	50
<b>36. Disposal</b>	<b>50</b>

## 17. Symbols used in this document



### Warning

*If these safety instructions are not observed, it may result in personal injury.*



### Warning

*If these instructions are not observed, it may lead to electric shock with consequent risk of serious personal injury or death.*



### Warning

*The surface of the product may be so hot that it may cause burns or personal injury.*



### Caution

*If these safety instructions are not observed, it may result in malfunction or damage to the equipment.*

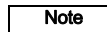

### Note

*Notes or instructions that make the job easier and ensure safe operation.*

## 18. Abbreviations and definitions

AI	Analog input.
AL	Alarm, out of range at lower limit.
AO	Analog output.
AU	Alarm, out of range at upper limit.
CIM	Communication interface module.
Current sinking	The ability to draw current into the terminal and guide it towards GND in the internal circuitry.
Current sourcing	The ability to push current out of the terminal and into an external load which must return it to GND.
DI	Digital input.
DO	Digital output.
ELCB	Earth leakage circuit breaker.
FM	Functional module.
GDS	Grundfos Digital Sensor. Factory-fitted sensor in some Grundfos pumps.
GENIbus	Proprietary Grundfos fieldbus standard.
GFCI	Ground fault circuit interrupter.
GND	Ground.
Grundfos Eye	Status indicator light.
LIVE	Low voltage with the risk of electric shock if the terminals are touched.
OC	Open collector: Configurable open-collector output.
PE	Protective earth.
PELV	Protective extra-low voltage. A voltage that cannot exceed ELV under normal conditions and under single-fault conditions, except earth faults in other circuits.
SELV	Safety extra-low voltage. A voltage that cannot exceed ELV under normal conditions and under single-fault conditions, including earth faults in other circuits.

## 19. General description

Grundfos MLE 80 and MLE 90 are frequency-controlled permanent-magnet motors suitable for single-phase AC or DC power supply. The motors incorporate a PI controller.

The motors can be connected to a signal from an external sensor and a setpoint signal enabling control in closed loop. The motors can also be used for an open-loop system in which the setpoint signal is used as a speed control signal.

The motors incorporate a control panel. See section 26. *User interfaces* for further information.

Detailed motor settings are made with the wireless Grundfos R100 remote control or Grundfos GO Remote. Furthermore, important operating parameters can be read via the R100 or Grundfos GO Remote.

The motors incorporate a functional module. See section 22.5 *Functional modules* for further information.

As an accessory option, the motors can be fitted with a Grundfos CIM module. A CIM module is an add-on communication interface module. The CIM module enables data transmission between the motor and an external system, for example a BMS or SCADA system. The CIM module communicates via fieldbus protocols.

### 19.1 Radio communication

This product incorporates a radio module for remote control.

This product can communicate with the Grundfos GO Remote and other MLE motors of the same type via the built-in radio module.

In some cases, an external antenna may be required.

Only Grundfos-approved external antennas may be connected to this product, and only by a Grundfos-approved installer.

### 19.2 Battery

A Li-ion battery is fitted in the FM 300 functional module.

The Li-ion battery of the FM 300 module complies with the Battery Directive (2006/66/EC). The battery does not contain mercury, lead and cadmium.

## 20. Identification

The motor can be identified by means of the nameplate on the terminal box.

### 20.1 Nameplate

The motor nameplate is located on the side of the terminal box. See fig. 1, pos. A.

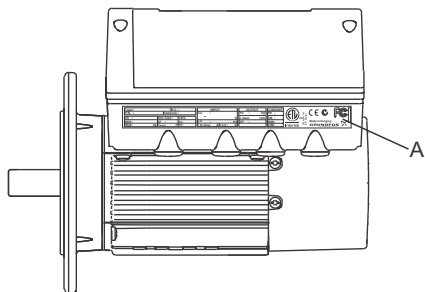

TM05 3489 3512

**Fig. 1** Nameplate location

Figure 2 shows the nameplate. The position numbers refer to the table below.

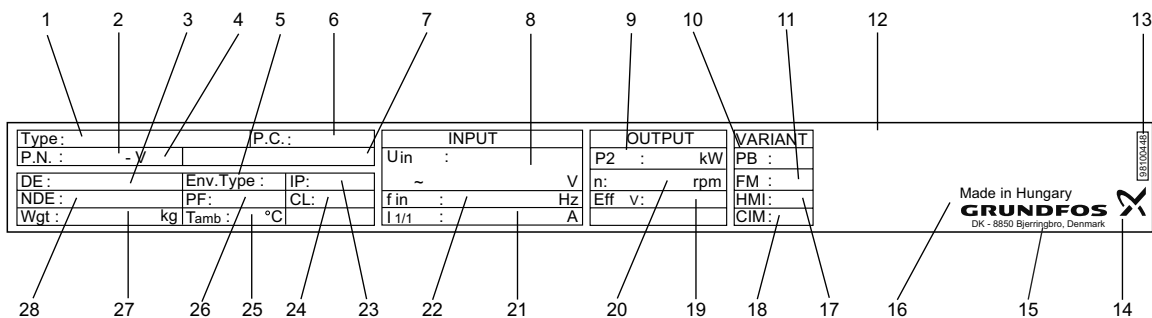

TM05 5246 3512

**Fig. 2** Nameplate, MLE motors

Pos.	Description
1	Type designation
2	Product number
3	Drive-end bearing
4	Environmental type
5	Production code (year and week)
6	Serial Number
7	Supply voltage [V]
8	Rated power output [kW] / [hp]
9	Power board type
10	Functional module type
11	CE mark and approvals
12	Part number of nameplate
13	Grundfos logo
14	Grundfos company address

Pos.	Description
15	Country of manufacture
16	Human Machine Interface type
17	CIM module type
18	Motor efficiency
19	Minimum and maximum motor speed [ $\text{min}^{-1}$ ] at full load
20	MGE: Maximum input current [A] MLE: Service factor current [A]
21	Mains frequency [Hz]
22	MGE: Enclosure class according to IEC 60034-5 MLE: Service factor
23	Service factor
24	Insulation class according to IEC 62114
25	Maximum ambient temperature [ $^{\circ}\text{C}$ ] / [F]
26	Power factor*
27	Weight [kg]
28	Non-drive-end bearing

\* Power factor  
 The power factor is defined as the ratio between active power and apparent power. This ratio is normally called  $\cos \varphi$ , but  $\cos \varphi$  is only defined for sinusoidal voltages and currents. When the mains power is supplied by a frequency converter, the current input is not sinusoidal. Therefore, the term power factor is used instead.  
**Reference:** See Common information, E-motor, section 3. *Frequency converter basics*.

## 20.2 Type key

Code	Example	ML	E	80	A	3-	14	56C	-H	A
ML	Motor Grundfos									
E	Electronic control									
80	Frame size according to IEC (center line height of motor shaft in mm, foot-mounted motor)									
90										
	<b>Length of stator core</b>									
					<b>Rated motor power P2 [HP]</b>					
A	1.18" (30 mm)				1.00					
C	2.36" (60 mm)				2.00					
3	3600 rpm									
	Shaft end diameter [mm]									
56C	<b>Flange version</b>									
	<b>Model designation</b>									
H	Single-phase									
I	Three-phase									
	<b>Version designation</b>									
A	First version									

## 21. Mechanical installation



**Warning**  
Installation and operation must comply with state, federal, and local regulations.

### 21.1 Handling



**Warning**  
Observe state, federal, and local regulations when setting limits for manual lifting or handling.



**Warning**  
Before lifting the motor, pay attention to the motor weight stated on the nameplate.

**Caution** Do not lift the motor by the terminal box.

When lifting the motor, always use the eyebolts, if fitted. Alternatively, lift the motor with both hands.

### 21.2 Mounting

The pump must be secured to a solid foundation by bolts through the holes in the flange or the base plate.

### 21.3 Cable entries

The motor has four M20 screwed cable entries fitted with blind plugs from factory.

The following cable glands are included:

- 2 X M20 cable gland, sensor/signal cables
- 1 X M20 cable gland, power supply cable.

## 21.4 Ensuring motor cooling

**Note**

In order to ensure sufficient cooling of the motor, the distance (D) between the end of the fan cover and a wall or other fixed objects must always be at least 2.00" (50 mm) mm, irrespective of motor size. See fig. 3.

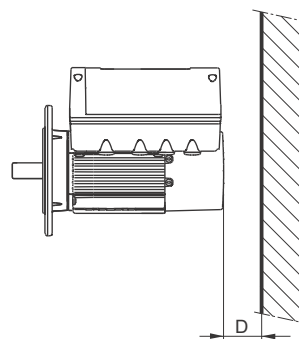

**Fig. 3** Minimum distance (D) from the motor to a wall or other fixed objects

TM05 5236 3512

## 21.5 Outdoor installation

When installed outdoors, the motor must be provided with a suitable cover to avoid condensation on the electronic components. See fig. 4.

**Note**

*When fitting a cover to the motor, observe the guideline in section 21.4 Ensuring motor cooling.*

The cover must be sufficiently large to ensure that the motor is not exposed to direct sunlight, rain or snow. Grundfos does not supply covers. We therefore recommend that you have a cover built for the specific application.

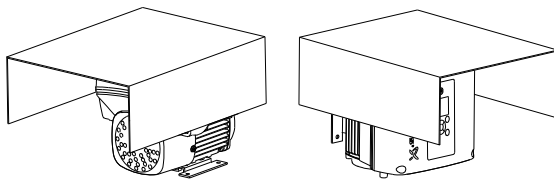

Fig. 4 Examples of covers (not supplied by Grundfos)

TM05 3496 3512

## 21.6 Drain holes

When the motor is installed in moist surroundings or areas with high air humidity, the bottom drain hole should be open. The enclosure class of the motor will then be lower. This helps prevent condensation in the motor as it will make the motor self-venting and allow water and humid air to escape.

The motor has a plugged drain hole on the drive side. The flange can be turned 90 ° to both sides or 180 °.

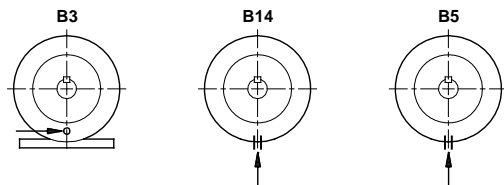

Fig. 5 Drain holes

TM02 9037 1604

## 22. Electrical installation

Carry out the electrical connection according to federal, state and local regulations.

Check that the supply voltage and frequency correspond to the values stated on the nameplate.

**Warning**

*Do not make any connections in the terminal box unless the power supply has been switched off for at least 5 minutes.*

*Make sure that the power supply cannot be accidentally switched on.*

*The motor must be grounded and protected against indirect contact in accordance with local regulations.*

*If the power supply cable is damaged, it must be replaced by the manufacturer, the manufacturer's service partner or a similarly qualified person.*

*The user or the installer is responsible for the installation of correct grounding and protection according to local regulations. All operations must be carried out by a qualified electrician.*

**Note**

### 22.1 Protection against electric shock, indirect contact

**Warning**

*The motor must be grounded and protected against indirect contact in accordance with state, federal, and local regulations.*

Ground conductors must always have a yellow/green (PE) or yellow/green/blue (PEN) color marking.

#### 22.1.1 Protection against mains voltage transients

The motor is protected against mains voltage transients in accordance with EN 61800-3.

#### 22.1.2 Motor protection

The motor requires no external motor protection. The motor incorporates thermal protection against slow overloading and blocking.

## 22.2 Cable requirements

### 22.2.1 Cable size

**Single-phase supply**

1.5 mm<sup>2</sup> / 12-14 AWG.

### 22.2.2 Conductors

**Type**

Stranded copper conductors only.

**Temperature rating**

Temperature rating for conductor insulation: 60 °C (140 °F).

Temperature rating for outer cable sheath: 75 °C (167 °F).

## 22.3 Power supply

### 22.3.1 Single-phase supply voltage

MLE Flex motors operate on the voltages below:

- 1 x 90-240 V - 10 %/+ 10 %, 50/60 Hz, PE or 30-300 VDC (power supply from a renewable-energy source).

Check that the supply voltage and frequency correspond to the values stated on the nameplate.

The wires in the motor terminal box must be as short as possible. Excepted from this is the separated earth conductor which must be so long that it is the last one to be disconnected in case the cable is inadvertently pulled out of the cable entry.

For maximum backup fuse, see section 33.1 *Supply voltage*.

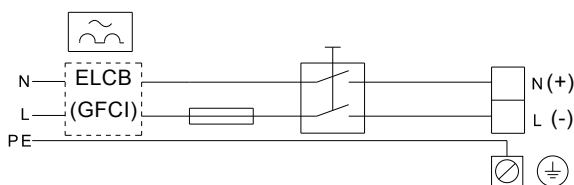

**Fig. 6** Example of a mains-connected motor with mains switch, backup fuse and additional protection

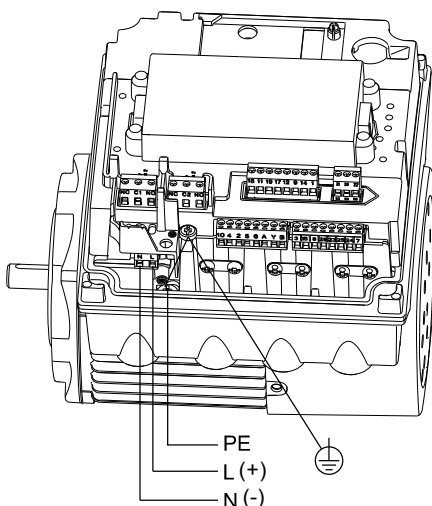
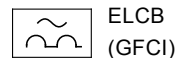

**Fig. 7** Mains connection, single-phase motors

## 22.4 Additional protection

### 22.4.1 Single-phase motors

If the motor is connected to an electric installation where an earth leakage circuit breaker (ELCB) or ground fault circuit interrupter (GFCI) is used as additional protection, this circuit breaker or interrupter must be marked with the following symbol:



ELCB  
(GFCI)

**Note**

***When an earth leakage circuit breaker or ground fault circuit interrupter is selected, the total leakage current of all the electrical equipment in the installation must be taken into account.***

The leakage current of the motor can be found in section 33.2 *Leakage current*.

### 22.4.2 Motors supplied from a renewable-energy source

This section only applies to motor variants designed for supply from a renewable-energy source (1 x 90-240 V - 10 %/+ 10 %, 50/60 Hz, PE or 30-300 VDC).

#### Overvoltage and undervoltage protection

Overvoltage and undervoltage may occur in case of unstable power supply or a faulty installation. The motor will be stopped if the voltage falls outside the permissible voltage range. The motor will automatically be restarted when the voltage is again within the permissible voltage range. Therefore, no additional protection relay is required.

**Note**

***The motor is protected against transients from the power supply according to EN 61800-3. In areas with high lightning intensity, we recommend external lightning protection.***

#### Overload protection

If the upper load limit is exceeded, the motor will automatically compensate for this by reducing the speed and stop if the overload condition persists.

The motor will remain stopped for 8 seconds. After this period, the motor will automatically attempt to restart. The overload protection prevents damage to the motor. Consequently, no additional motor protection is required.

#### Overtemperature protection

The electronic unit has a built-in temperature sensor as an additional protection. When the temperature rises above a certain level, the motor will automatically compensate for this by reducing the speed and stop if the temperature keeps rising.

The motor will remain stopped for 8 seconds. After this period, the motor will automatically attempt to restart.

#### Protection against phase unbalance

The motor must be connected to a power supply with a quality corresponding to IEC 60146-1-1, class C, to ensure correct motor operation at phase unbalance.

This also ensures long life of the components.

## 22.5 Functional modules

MLE Flex motors are supplied with the advanced functional module (FM 300)

TM05 4034 1912

TM05 3494 1512

### 23. Basic CRFlex control connections

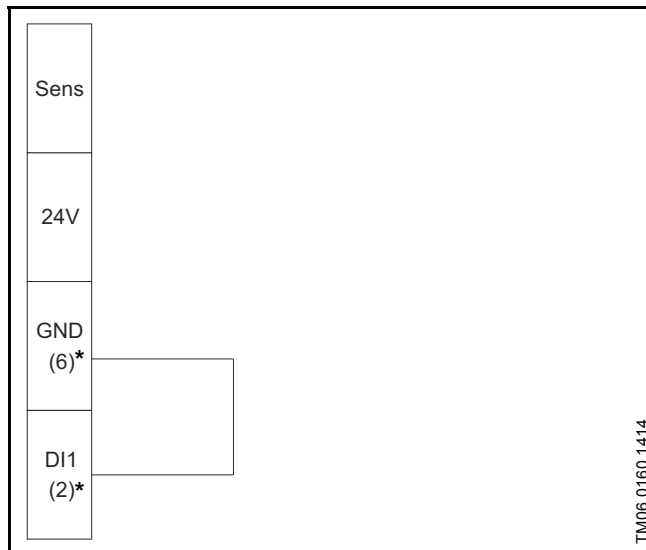

**Fig. 8** Jumper Wire

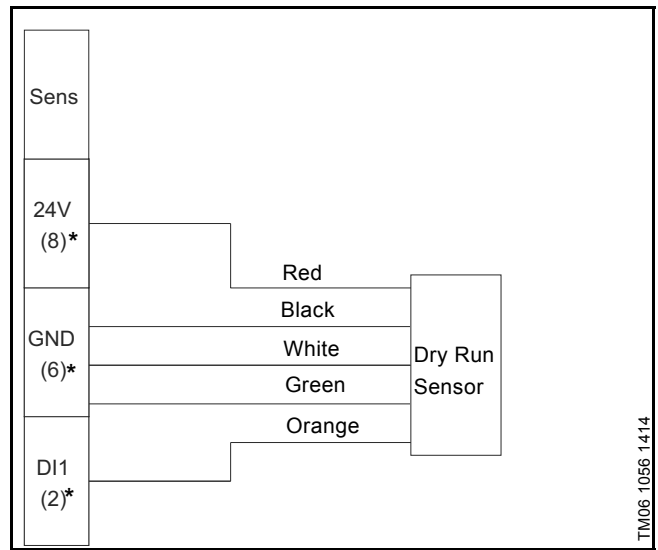

**Fig. 11** Dry run sensor

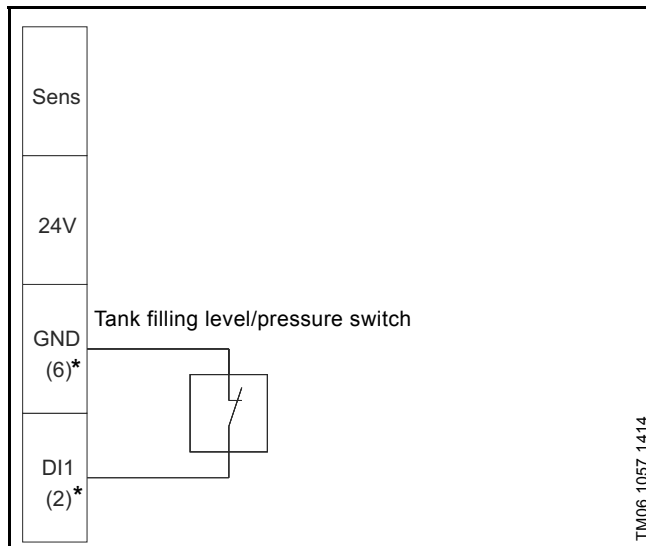

**Fig. 9** Level/Pressure switch

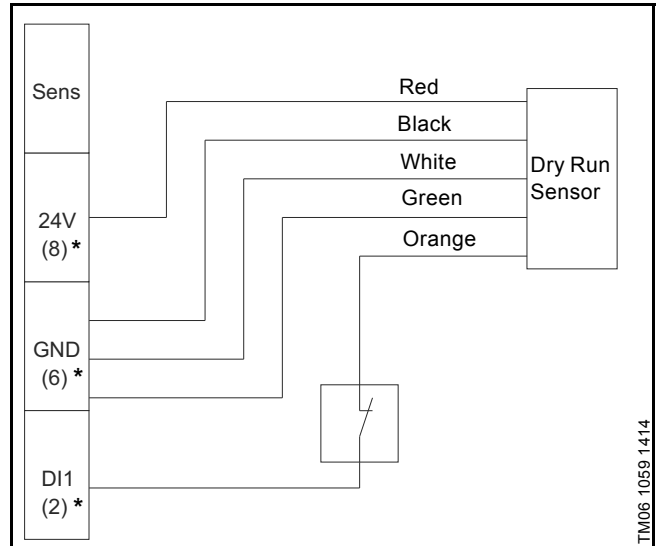

**Fig. 12** Dry run sensor with level/pressure switch

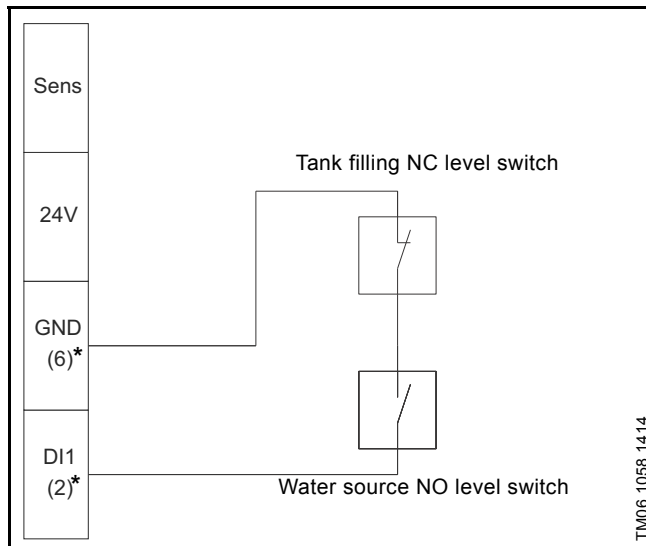

**Fig. 10** Multi switch configuration

**\* Note** Number in parenthesis ( ) denotes wire terminal.



### Advanced functional module (FM 300)

The FM 300 has a number of inputs and outputs enabling the motor to be used in advanced applications where many inputs and outputs are required.

The FM 300 has these connections:

- three analog inputs
- one analog output
- two dedicated digital inputs
- two configurable digital inputs or open-collector outputs
- Grundfos Digital Sensor input and output
- two Pt100/1000 inputs
- two signal relay outputs
- GENIbus connection.

See fig. 13.

***Digital input 1 is factory-set to be start/stop input where open circuit will result in stop. A jumper has been factory-fitted between terminals 2 and 6. Remove the jumper if digital input 1 is to be used as external start/stop or any other external function.***

Note

***As a precaution, the wires to be connected to the connection groups below must be separated from each other by reinforced insulation in their entire lengths.***

Note

#### Inputs and outputs

All inputs and outputs are internally separated from the mains-conducting parts by reinforced insulation and galvanically separated from other circuits.

All control terminals are supplied by safety extra-low voltage (SELV), thus ensuring protection against electric shock.

- Start/stop: (digital input 1) terminals 2 and 6
- pressure sensor: (analog input 1) terminals 4 and 8
- pressure switch: (digital input 3) terminals 10 and 6
- external analog signal input: (analog input 2) terminals 7 and 23
- genibus terminals a, y and b.

#### Signal relay outputs

##### – Signal relay 1:

LIVE:

Power supply voltages up to 250 VAC can be connected to this output.

SELV:

The output is galvanically separated from other circuits.

Therefore, the supply voltage or safety extra-low voltage can be connected to the output as desired.

##### – Signal relay 2:

SELV:

The output is galvanically separated from other circuits.

Therefore, the supply voltage or safety extra-low voltage can be connected to the output as desired.

#### Power supply (terminals N, PE, L).

A galvanically safe separation must fulfil the requirements for reinforced insulation including creepage distances and clearances specified in EN 61800-5-1.

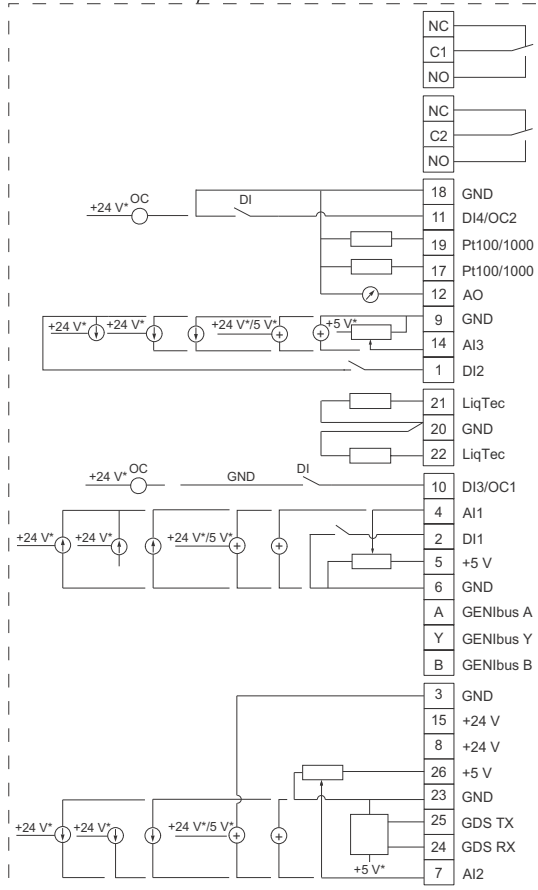
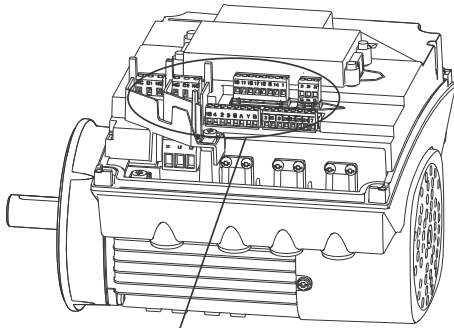

\* If an external supply source is used, there must be a connection to GND.

**Fig. 13** Connection terminals, FM 300

TM05 3509 3512

Terminal	Type	Function
NC	Normally closed contact	Signal relay 1 (LIVE or SELV)
C1	Common	
NO	Normally open contact	
NC	Normally closed contact	Signal relay 2 (SELV only)
C2	Common	
NO	Normally open contact	
18	GND	Ground
11	DI4/OC2	Digital input/output, configurable. Open collector: Max. 24 V resistive or inductive.
19	Pt100/1000 input 2	Pt100/1000 sensor input
17	Pt100/1000 input 1	Pt100/1000 sensor input
12	AO	Analogue output: 0-20 mA / 4-20 mA 0-10 V
9	GND	Ground
14	AI3	Analogue input: 0-20 mA / 4-20 mA 0-10 V
1	DI2	Digital input, configurable
10	DI3/OC1	Digital input/output, configurable. Open collector: Max. 24 V resistive or inductive.
4	AI1	Analogue input: 0-20 mA / 4-20 mA 0.5 - 3.5 V / 0-5 V / 0-10 V
2	DI1	Digital input, configurable
5	+5 V	Supply to potentiometer and sensor
6	GND	Ground
A	GENIbus, A	GENIbus, A (+)
Y	GENIbus, Y	GENIbus, GND
B	GENIbus, B	GENIbus, B (-)
3	GND	Ground
15	+24 V	Supply
8	+24 V	Supply
26	+5 V	Supply to potentiometer and sensor
23	GND	Ground
25	GDS TX	Grundfos Digital Sensor output
24	GDS RX	Grundfos Digital Sensor input
7	AI2	Analogue input: 0-20 mA / 4-20 mA 0.5 - 3.5 V / 0-5 V / 0-10 V

### 23.1 Signal cables

- Use screened cables with a cross-sectional area of min. 28 AWG (0.08 mm<sup>2</sup>) and max. 16 AWG (1.50 mm<sup>2</sup>) for external on/off switch, digital inputs, setpoint and sensor signals.
- Connect the screens of the cables to frame at both ends with good connection. The screens must be as close as possible to the terminals. See fig. 14.

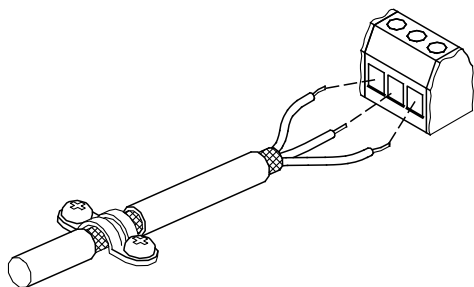

Fig. 14 Stripped cable with screen and wire connections

- Screws for frame connections must always be tightened whether a cable is fitted or not.
- The wires in the motor terminal box must be as short as possible.

### 23.2 Bus connection cable

#### 23.2.1 New installations

For the bus connection, use a screened 3-core cable with a cross-sectional area of min. 28 AWG (0.08 mm<sup>2</sup>) and max. 16 AWG (1.50 mm<sup>2</sup>).

- If the motor is connected to a unit with a cable clamp which is identical to the one on the motor, connect the screen to this cable clamp.
- If the unit has no cable clamp as shown in fig. 15, leave the screen unconnected at this end.

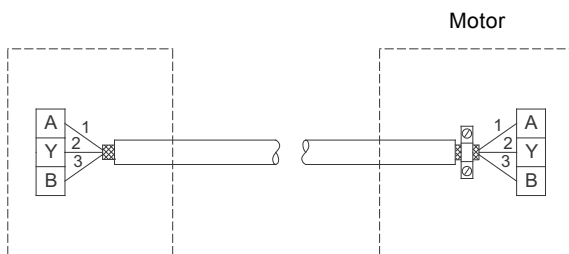

Fig. 15 Connection with screened 3-core cable

#### 23.2.2 Replacing an existing motor

- If a screened 2-core cable is used in the existing installation, connect it as shown in fig. 16.

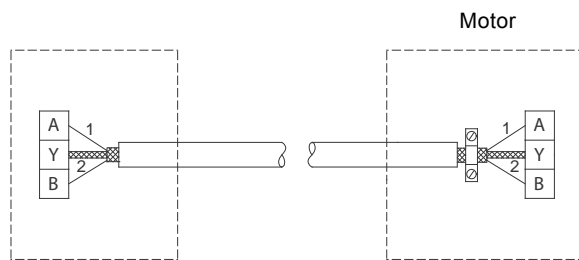

Fig. 16 Connection with screened 2-core cable

- If a screened 3-core cable is used in the existing installation, follow the instructions in section 23.2.1 *New installations*.

### 24. Operating conditions

#### 24.1 Maximum number of starts and stops

The number of starts and stops via the power supply must not exceed four times per hour.

When switched on via the power supply, the motor will start after approx. 5 seconds.

If a higher number of starts and stops is desired, use the input for external start/stop when starting/stopping the motor.

When started via an external on/off switch, the motor will start immediately.

#### 24.2 Ambient temperature

##### 24.2.1 Ambient temperature during storage and transportation

Minimum -22 °F (-30 °C)

Maximum 140 °F (60 °C).

##### 24.2.2 Ambient temperature during operation

Minimum -4 °F (-20 °F)

Maximum +122 °F (50 °C).

The motor can operate with the rated power output (P<sub>2</sub>) at +122 °F (50 °C), but continuous operation at higher temperatures will reduce the expected product life. If the motor is to operate at ambient temperatures between +122 °F (50 °C) and 140 °F (60 °C), an oversized motor must be selected. Contact Grundfos for further information.

#### 24.3 Installation altitude

**Caution** *The motor must not be installed more than 6560 ft (2000 m) above sea level.*

Installation altitude is the height above sea level of the installation site.

- Motors installed up to 3280 ft (1000 m) above sea level can be loaded 100 %.
- Motors installed more than 3280 ft (1000 m) above sea level must not be fully loaded due to the low density and consequent low cooling effect of the air. See fig. 17.

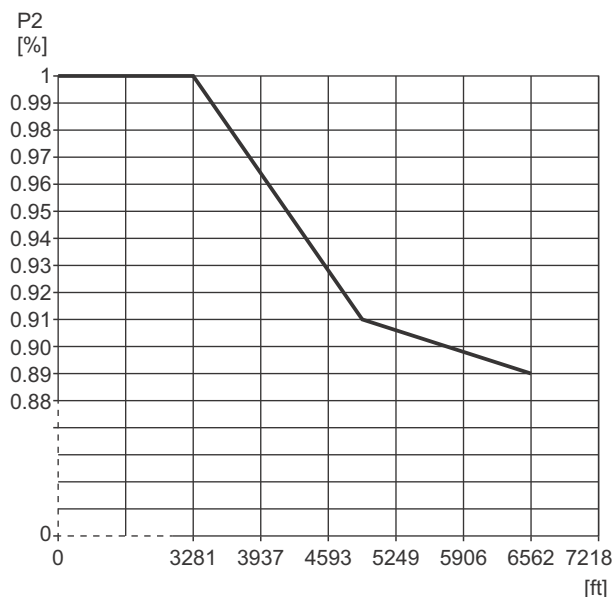

Fig. 17 Derating of motor output power (P<sub>2</sub>) in relation to altitude above sea level

## 24.4 Air humidity

Maximum air humidity: 95 %.

If the air humidity is constantly high and above 85 %, the drain holes in the drive-end flange should be open. See section 21.6 *Drain holes*.

## 24.5 Motor cooling

To ensure cooling of motor and electronics, the following must be observed:

- Position the motor in such a way that adequate cooling is ensured. See section 21.4 *Ensuring motor cooling*.
- The temperature of the cooling air must not exceed +122 °F (50 °C).
- Keep cooling fins and fan blades clean.

## 25. Operating and control modes

Grundfos E-pumps are set and controlled according to operating and control modes.

### 25.1 Overview

#### Operating modes

- Normal
- Stop
- Min.
- Max.
- Manual

#### Control modes

- Constant pressure
- Constant differential pressure
- Constant temperature
- Constant differential temperature
- Constant flow rate
- Constant level
- Constant curve
- Constant other value

#### Example

If the pump is fitted with a pressure sensor, the control mode must be set to constant pressure. If the pump is for instance fitted with a temperature sensor, the control mode should be constant temperature.

## 25.2 Operating mode

When the operating mode is set to "Normal", the control mode can be set to constant curve or any other control mode.

Other operating modes:

- Stop  
The pump has been stopped.
- Min.  
The pump is operating at its minimum speed.
- Max.  
The pump is operating at its maximum speed.
- Manual  
The pump is operating at a manually set speed.

Figure 18 illustrates the min. and max. curves.

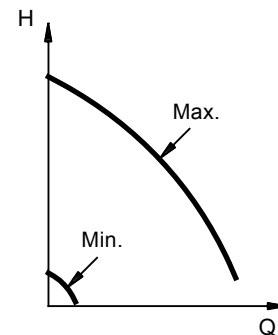

Fig. 18 Min. and max. curves

The max. curve can for instance be used in connection with the venting procedure during installation.

The min. curve can be used in periods in which a minimum flow is required.

If the power supply to the pump is disconnected, the setting of operating mode will be stored.

## 26. User interfaces



#### Warning

**The product may be so hot that only the buttons should be touched to avoid burns.**

Motor settings can be made by means of the following user interfaces:

#### Control panels

The MLE Flex motor incorporates the standard control panel. See section 26.1 *Standard control panel*.

#### Remote controls

- Grundfos R100 remote control.  
See section 26.3 *R100 remote control*.
- Grundfos GO Remote.  
See section 26.4 *Grundfos GO Remote*.

If the power supply to the motor is switched off, the motor settings will be stored.

## 26.1 Standard control panel

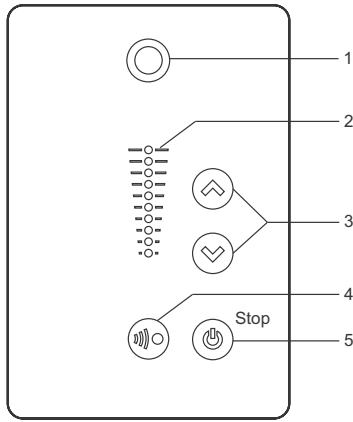

Fig. 19 Standard control panel

Pos.	Symbol	Description
1		Grundfos Eye Shows the operating status of the motor. See section 30. <i>Grundfos Eye</i> for further information.
2	-	Light fields for indication of setpoint.
3		Changes the setpoint.
4		Enables radio communication with the Grundfos GO Remote and with other MLE motors of the same type.
5		Makes the motor ready for operation/starts and stops. <b>Start:</b> If the button is pressed when the motor is stopped, the motor will only start if no other functions with higher priority have been enabled. See section 28. <i>Priority of settings</i> . <b>Stop:</b> If the button is pressed when the motor is running, the motor will always be stopped. When the motor is stopped, the "Stop" text next to the button will illuminate.

### 26.1.1 Setpoint setting

Set the desired setpoint of the motor by pressing or . The green light fields on the control panel will indicate the setpoint set.

#### Motor in controlled-operation mode

The following example applies to a pump in an application where a pressure sensor gives a feedback to the pump. The sensor is set up manually, and the pump does not automatically register a connected sensor.

Figure 20 shows that the light fields 5 and 6 are activated, indicating a desired setpoint of 43 psi (3 bar) with a sensor measuring range from 0 to 87 psi (0 to 6 bar). The setting range is equal to the sensor measuring range.

TM05 4848 3512

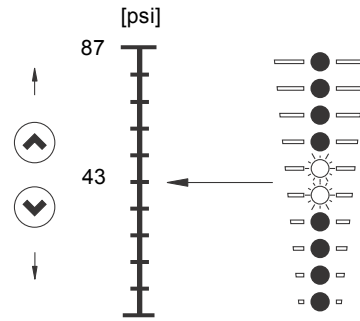

Fig. 20 Setpoint set to 43 psi (3 bar), pressure-control mode

#### Motor in uncontrolled-operation mode

In uncontrolled-operation mode, the motor output will lie between max. and min. speed. See fig. 21.

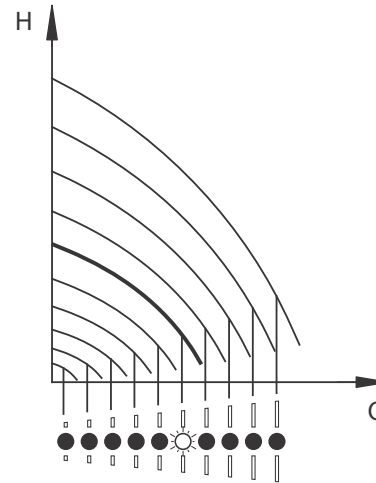

Fig. 21 Motor in uncontrolled-operation mode

#### Setting to max. speed

Press continuously to change over to the max. speed (top light field flashes). When the top light field is on, press for 3 seconds until the light field starts flashing.

To change back, press continuously until the desired setpoint is indicated.

**Example:** Motor set to max. speed.

Figure 22 shows that the top light field is flashing, indicating max. speed.

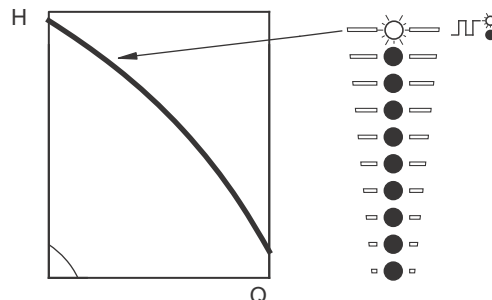

Fig. 22 Max. speed duty

TM06 1116 1714

TM05 4895 2812

TM05 4896 2812

### Setting to min. speed

Press continuously to change over to the min. speed (bottom light field flashes). When the bottom light field is on, press for 3 seconds until the light field starts flashing.

To change back, press continuously until the desired setpoint is indicated.

**Example:** Motor set to min. speed.

Figure 23 shows that the bottom light field is flashing, indicating min. speed.

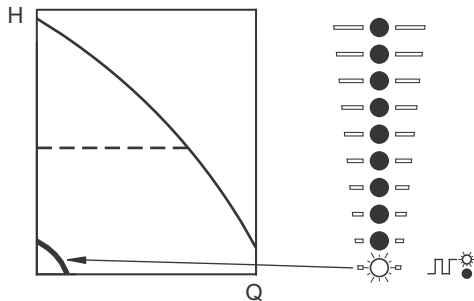

Fig. 23 Min. speed duty

### 26.1.2 Start/stop of motor

Stop the motor by pressing . When the motor is stopped, the "Stop" text next to the button will illuminate. The motor can also be stopped by continuously pressing until none of the light fields are on.

Start the motor by pressing or by continuously pressing until the desired setpoint is indicated.

If the motor has been stopped by pressing , it can only be given free to operation by pressing again.

If the motor has been stopped by pressing , it can only be restarted by pressing .

The motor can also be stopped with the R100, Grundfos GO Remote or via a digital input set to "External stop". See section 28. *Priority of settings.*

### 26.1.3 Resetting of alarms and warnings

A fault indication can be reset in one of the following ways:

- Via the digital input if it has been set to "Alarm resetting".
- Briefly press or on the motor. This will not change the setting of the motor.

A fault indication cannot be reset by pressing or if the buttons have been locked.

- Switch off the power supply until the indicator lights are off.
- Switch the external start/stop input off and then on again.
- With the R100. See section *Alarm*, page 33.
- With the Grundfos GO Remote.

## 26.2 Changing the position of the control panel

It is possible to turn the control panel 180°. Follow the instructions below.

1. Loosen the four screws (TX25) holding the terminal box cover.

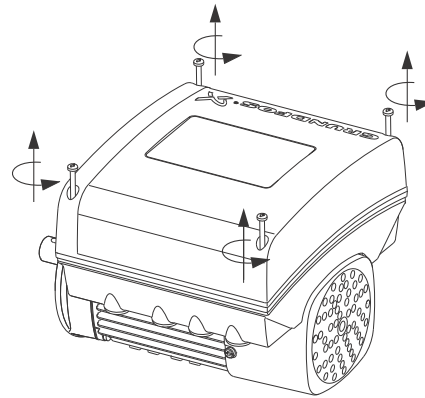

Fig. 24 Loosening the screws

2. Remove the terminal box cover.

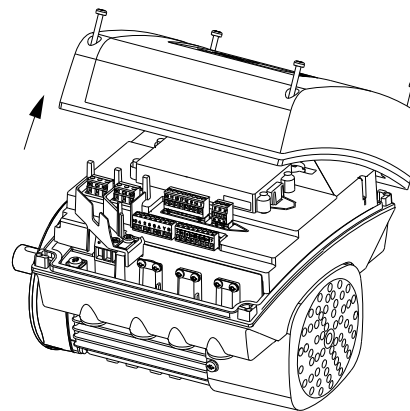

Fig. 25 Removing the terminal box cover

3. Press and hold in the two locking tabs (pos. A) while gently lifting the plastic cover (pos. B).

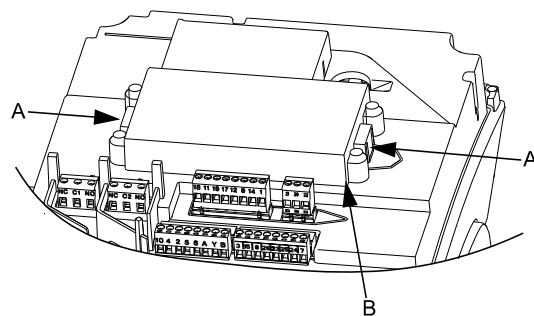

Fig. 26 Lifting the plastic cover

TM05 4897 2812

TM05 5351 3612

TM05 5352 3612

TM05 5353 3612

4. Turn the plastic cover 180 °.

**Note** Do not twist the cable more than 90 °.

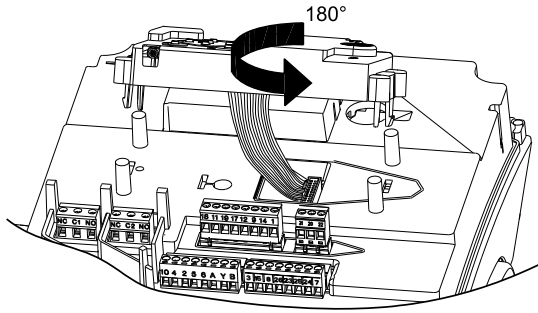

TM05 5354 3612

**Fig. 27** Turning the plastic cover

5. Re-position the plastic cover correctly on the four rubber pins (pos. C). Make sure that the locking tabs (pos. A) are placed correctly.

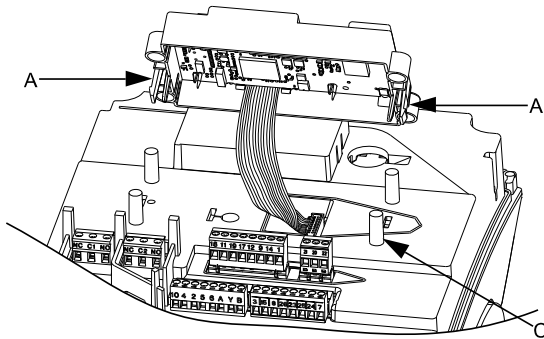

TM05 5355 3612

**Fig. 28** Re-positioning the plastic cover

6. Fit the terminal box cover, and make sure that it is also turned 180 ° so that the buttons on the control panel are aligned with the buttons on the plastic cover. Tighten the four screws (TX25) with 3.7 ft-lb (5 Nm).

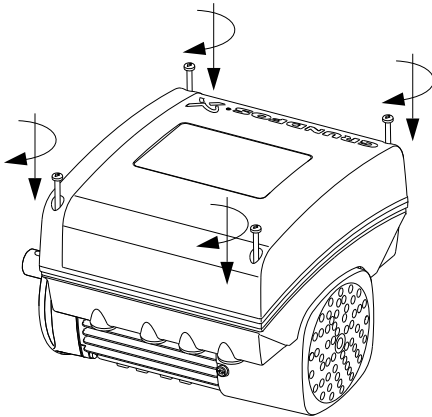

TM05 5356 3612

**Fig. 29** Fitting the terminal box cover

### 26.3 R100 remote control

The motor is designed for wireless communication with the Grundfos R100 remote control.

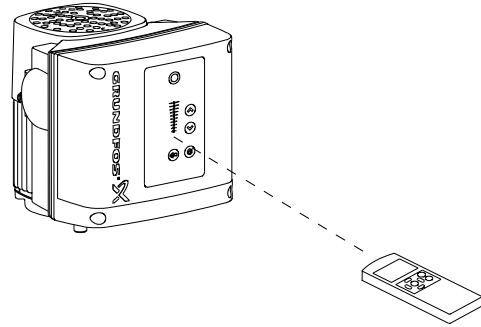

TM05 3933 1712

**Fig. 30** R100 communicating with the motor via infrared light

During communication, the R100 must be pointed at the control panel. When the R100 communicates with the motor, the indicator light in the middle of the Grundfos Eye will flash green. See page 47.

The R100 offers additional possibilities of setting and status displays for the motor.

The displays are divided into four parallel menus:

- 0. GENERAL (see operating instructions for the R100)
- 1. OPERATION
- 2. STATUS
- 3. INSTALLATION.

See section 26.3.1 R100 menu structure.

## 26.3.1 R100 menu structure

## 0. GENERAL

- Switch off R100
- Return to start
- Delete all changes
- Store settings
- Call up settings
- Store status data
- Call up status data

## 1. OPERATION

- *Setpoint*
- *Operating mode*
- *Manual speed*
- *Alarm*
- *Warning*
- *Alarm log 1 to 5*
- *Warning log 1 to 5*

## 2. STATUS

- *Actual setpoint and external setpoint*
- *Operating mode*
- *Actual controlled value*
- *Analog input 1, 2 and 3*
- *Pt100/1000 input 1 and 2*
- *Speed*
- *Power input and power consumption*
- *Operating hours*
- *Replace motor bearings*
- *Motor current*

## 3. INSTALLATION

- *Control mode*
- *Controller*
- *Signal relay 1 and 2*
- *Buttons on motor*
- *Number*
- *Radio communication*
- *Digital input 1 and 2, Function*
- *Digital input/output 3 and 4, State*
- *Digital input/output 3 and 4, Function*
- *Analog input 1, 2 and 3, Function*
- *Analog input 1, 2 and 3, Measured parameter*
- *Analog input 1, 2 and 3*
- *Pt100/1000 input 1 and 2, Function*
- *Pt100/1000 input 1 and 2, Measured parameter*
- *Operating range*
- *Ramps*
- *Direction of rotation*
- *Motor bearing monitoring*
- *Motor bearings*
- *Standstill heating*



### 26.3.2 OPERATION menu

When communication between the R100 and the motor has been established, the first display in this menu will appear.

#### Setpoint

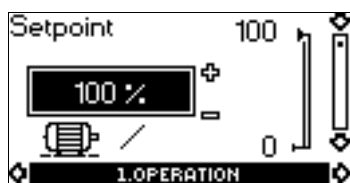

Set the desired setpoint in this display.

- ▶ Setpoint set
- Actual setpoint
- Actual value

#### Open-loop operation

If the motor has been set to open-loop operation, the setpoint is set in % of the maximum possible speed of the motor.

The setting range will lie between min. speed and max. speed, for instance between 12 and 67 % of the maximum possible speed. See the example in fig. 31.

#### Closed-loop operation

If the motor has been set to closed-loop operation, the setpoint is set in the measuring unit used by the sensor.

The setting range lies between the set minimum and maximum sensor values.

If the motor is connected to an external setpoint signal, the value in this display will be the maximum value of the external setpoint signal. See section 27. *Bus signal*.

If the motor is controlled via external signals or a bus, this will be indicated in the display if setpoint setting is attempted.

In this case, the number of possible settings will be reduced.

See section 28. *Priority of settings*.

#### Operating mode

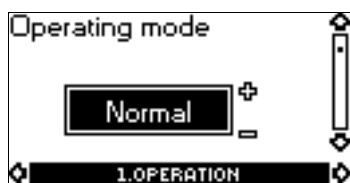

Select one of the following operating modes:

- Stop
- Min. (min. speed)
- Normal (duty)
- Max. (max. speed)
- Manual (operation).

The operating modes can be selected without changing the setpoint setting.

#### Manual speed



In this display, the motor speed can be set in %. When the operating mode has been set to "Manual", the motor will run at the set speed.

#### Alarm

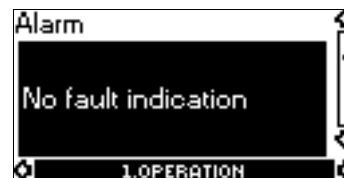

In case of an alarm, the cause will appear in the display together with a fault code.

#### Possible alarms:

Alarm	Fault code
External fault	3
Too many restarts	4
Forced pumping	29
Overvoltage	32
Undervoltage	40
Overload	49
Blocked pump	51
Dry running	56, 57
Too high motor temperature	65
Electronics temperature too high	66
Internal communication fault	76
Internal fault	83, 85
Sensor signal outside signal range	88
Temperature sensor 1 outside signal range	91
Internal fault	163
LiqTec sensor fault	164
Signal outside range, analog input 1	165
Signal outside range, analog input 2	166
Signal outside range, analog input 3	167
Temperature sensor 2 outside signal range	175
Limit 1 exceeded	190
Limit 2 exceeded	191

A fault indication can be reset in this display by pressing [OK] if the cause of the fault has disappeared.

## Warning

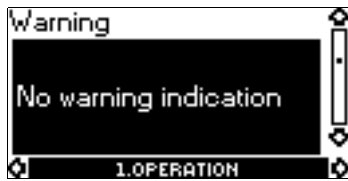

In case of a warning, the cause will appear in this display together with a fault code.

Possible warnings:

Warning	Fault code
No contact to pump	10
Replace motor bearings	30
Too high motor temperature	65
Electronics temperature too high	66
Internal fault	83, 85, 163
Sensor signal outside signal range	88
Temperature sensor 1 outside signal range	91
Sensor supply fault, 5 V	161
Sensor supply fault, 24 V	162
LiqTec sensor fault	164
Signal outside range, analog input 1	165
Signal outside range, analog input 2	166
Signal outside range, analog input 3	167
Temperature sensor 2 outside signal range	175
Limit 1 exceeded	190
Limit 2 exceeded	191

A warning indication will disappear automatically once the fault has been remedied.

## Alarm log 1 to 5



In case of "alarm" faults, the last five alarm indications will appear in the alarm log. "Alarm log 1" shows the latest fault, "Alarm log 2" shows the latest fault but one, etc.

The example above gives this information:

- The alarm indication "Other fault".
- The fault code "(73)".
- The number of minutes the motor has been connected to the power supply after the fault occurred.

## Warning log 1 to 5

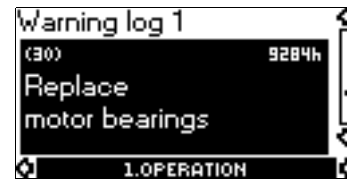

In case of "warning" faults, the last five warning indications will appear in the warning log. "Warning log 1" shows the latest fault, "Warning log 2" shows the latest fault but one, etc.

The example above gives this information:

- The warning indication "Replace motor bearings".
- The fault code "(30)".
- The number of minutes the motor has been connected to the power supply after the fault occurred.

## 26.3.3 STATUS menu

The displays appearing in this menu are status displays only. It is not possible to change or set values.

The displayed values are the values that applied when the last communication between the motor and the R100 took place. If a status value is to be updated, point the R100 at the control panel and press [OK].

If a parameter, for example speed, should be called up continuously, press [OK] constantly during the period in which the parameter in question should be monitored.

The tolerance of the displayed value is stated under each display. The tolerances are stated as a guide in % of the maximum values of the parameters.

## Actual setpoint and external setpoint

## Without sensor

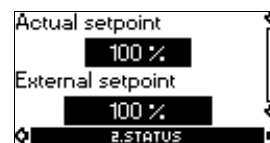

Tolerance: ± 2 %.

## With pressure sensor

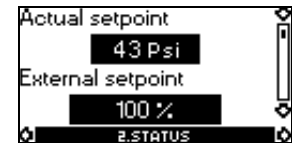

Tolerance: ± 2 %.

This display shows the actual setpoint and the external setpoint in % of the range from minimum value of sensor measuring range to the setpoint set.

At a min. speed of 12 %, a set setpoint of 65 % and an external setpoint of 70 %, the actual setpoint will be  $0.70 \times (65 - 12) + 12 = 49 \%$ .

## Operating mode

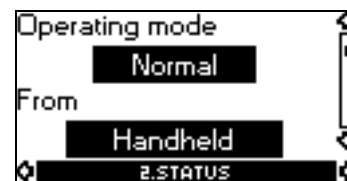

This display shows the actual operating mode (Stop, Min., Normal (duty), Max. or Manual (operation)). Furthermore, it shows where this operating mode was selected (Handheld, Motor, Bus, External or Start/stop button).

**Actual controlled value**

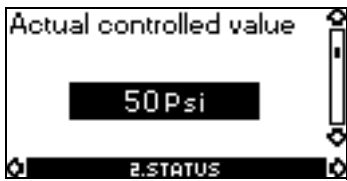

The actual controlled value will appear in this display if a sensor has been connected and the function of the analog input has been set to "Feedback sensor".

See section *Analog input 1, 2 and 3, Function*, page 39.

**Analog input 1, 2 and 3**

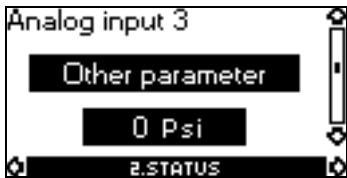
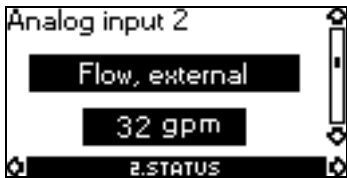

These displays show the measured parameter and the corresponding value.

The number of available displays depends on the functional module fitted in the motor. See below.

Function (terminal)	FM 300
Analog input 1 (4)	•
Analog input 2 (7)	•
Analog input 3 (14)	•

**Pt100/1000 input 1 and 2**

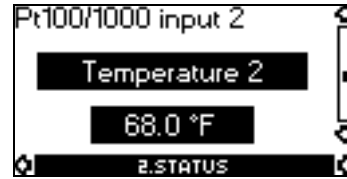
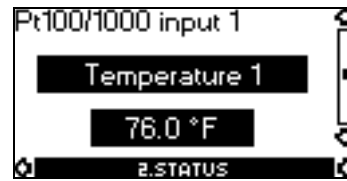

These displays show the measured parameter and the corresponding value. The measured temperatures will appear in these displays if Pt100 or Pt1000 sensors have been connected. The number of available displays depends on the functional module fitted in the motor. See below.

Function (terminal)	FM 300
Pt100/1000 input 1 (17)	•
Pt100/1000 input 2 (19)	•

**Speed**

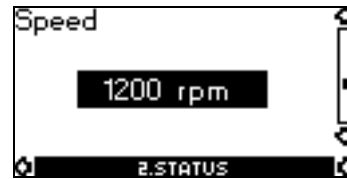

Tolerance: ± 5 %.

This display shows the actual speed.

**Power input and power consumption**

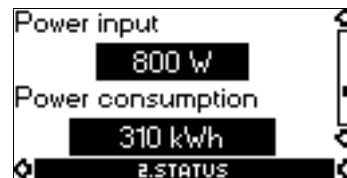

Tolerance: ± 10 %

- "Power input" indicates the actual power consumption.
- "Power consumption" indicates an accumulated value which cannot be reset.

## Operating hours



Tolerance:  $\pm 2\%$

The value of operating hours is an accumulated value and cannot be reset.

## Replace motor bearings



This display shows when to replace the motor bearings. The controller monitors the operating pattern of the motor and calculates the period between bearing replacements.

Displayable values:

- in 2 years
- in 1 year
- in 6 months
- in 3 months
- in 1 month
- in 1 week
- Now!

## Motor current

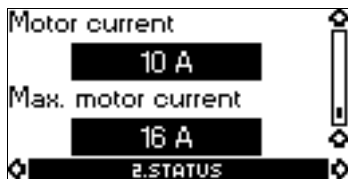

Tolerance:  $\pm 5\%$

- "Motor current" indicates the actual motor input current from the frequency converter.
- "Max. motor current" indicates the maximum motor current limit.

## 26.3.4 INSTALLATION menu

### Control mode



Select one of the following control modes:

- Closed loop
- Open loop.

#### Note

*If the motor is connected to a bus (see section 27. Bus signal), it is not possible to select the control mode via the R100.*

### Controller

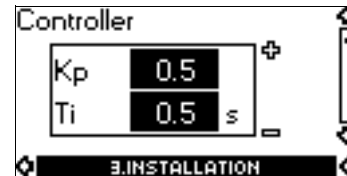

In this display, the gain ( $K_p$ ) and the integral-action time ( $T_i$ ) of the built-in PI controller can be set if the factory setting is not the optimum setting:

- Set the gain ( $K_p$ ) within the range from 0.1 to 20.
- Set the integral-action time ( $T_i$ ) within the range from 0.1 to 3600 s.  
If 3600 s is selected, the controller will function as a P controller.

### Inverse control

It is possible to set the controller to inverse control (if the setpoint is increased, the speed will be reduced). In the case of inverse control, the gain ( $K_p$ ) must be set within the range from -0.1 to -20.

## Signal relay 1 and 2



The signal relays can be configured to be activated by one of the following incidents:



- Ready
- Operation
- Alarm
- Warning
- Limit 2 exceeded
- Limit 1 exceeded
- Running
- Not active.

The number of available displays depends on the functional module fitted in the motor. See below.

Function (terminal)	FM 300
Signal relay 1 (NC, C1, NO)	•
Signal relay 2 (NC, C2, NO)	•

### Buttons on motor



The buttons  and  on the motor can be set to the following:

- Active
- Not active.

### Number



A number between 1 and 64 can be allocated to the motor or can be changed. In the case of bus communication, a number must be allocated to each motor.

## Radio communication



In this display, wireless radio communication can be enabled or disabled. The wireless, infrared communication will not be affected by the settings made in this display.

Possible settings:

- Active
- Not active.

### Digital input 1 and 2, Function

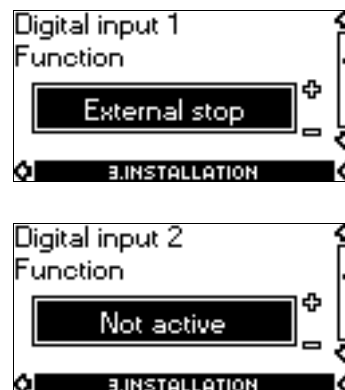

The digital inputs 1 and 2 can be set to various functions.

Select one of these functions:

- "Not active":  
When set to "Not active", the input has no function.
- "External fault":  
When the input is activated, a timer will be started. If the input is activated for more than 5 seconds, the motor will be stopped and a fault will be indicated. If the connection is disconnected for more than 5 seconds, the fault condition will cease and the motor will start if automatic restarting has been selected via PC Tool.
- "Alarm resetting":  
When the input is activated, a possible fault indication will be reset.
- "Reversing":  
When the input is activated, the direction of rotation of the motor will be reversed compared to the setting made in *Direction of rotation*, page 41.
- "External stop":  
When the input is deactivated (open circuit), the motor will stop.
- "Max." (max. speed):  
When the input is activated, the motor will run at the set max. speed.
- "Min." (min. speed):  
When the input is activated, the motor will run at the set min. speed.

The priority of the selected functions in relation to each other appears from section 28. *Priority of settings*.

A stop command will always have the highest priority.

The number of available displays depends on the functional module fitted in the motor. See below.

Function (terminal)	FM 300
Digital input 1, Function (2 and 6)	•
Digital input 2, Function (1 and 9)	•

**Digital input/output 3 and 4, State**



The digital input/output 3 and 4 can be set to act as digital input or digital output.

Possible settings:

- Digital input
- Digital output.

The number of available displays depends on the functional module fitted in the motor. See below.

Function (terminal)	FM 300
Digital input/output 3, State (10 and 6)	•
Digital input/output 4, State (11 and 18)	•

**Digital input/output 3 and 4, Function**



The digital input/output 3 and 4 can be set to these functions:

**Possible functions, digital input/output 3**

Set to digital input	Set to digital output
<ul style="list-style-type: none"> <li>• Not active</li> <li>• External fault</li> <li>• Alarm resetting</li> <li>• Reversing</li> <li>• External stop</li> <li>• Max.</li> <li>• Min.</li> </ul>	<ul style="list-style-type: none"> <li>• Ready</li> <li>• Operation</li> <li>• Alarm</li> <li>• Warning</li> <li>• Limit 2 exceeded</li> <li>• Limit 1 exceeded</li> <li>• Running</li> <li>• Not active</li> </ul>

**Possible functions, digital input/output 4**

Set to digital input	Set to digital output
<ul style="list-style-type: none"> <li>• Not active</li> <li>• External fault</li> <li>• Alarm resetting</li> <li>• Reversing</li> <li>• External stop</li> <li>• Max.</li> <li>• Min.</li> </ul>	<ul style="list-style-type: none"> <li>• Ready</li> <li>• Operation</li> <li>• Alarm</li> <li>• Warning</li> <li>• Limit 2 exceeded</li> <li>• Limit 1 exceeded</li> <li>• Running</li> <li>• Not active</li> </ul>

The number of available displays depends on the functional module fitted in the motor. See below.

Function (terminal)	FM 300
Digital input/output 3, Function (10 and 6)	•
Digital input/output 4, Function (11 and 18)	•

Analog input 1, 2 and 3, Function

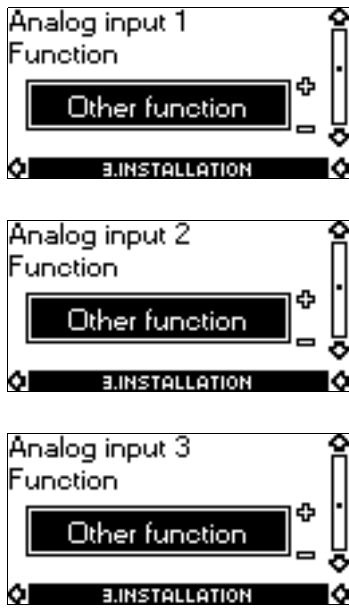

The analog inputs can be set to these functions:

- Not active
- Feedback sensor
- Ext. setpoint infl.  
For further description, see section 27. *Bus signal*.
- Other function.

The number of available displays depends on the functional module fitted in the motor. See below.

Function (terminal)	FM 300
Analog input 1, Function (4)	•
Analog input 2, Function (7)	•
Analog input 3, Function (14)	•

Analog input 1, 2 and 3, Measured parameter

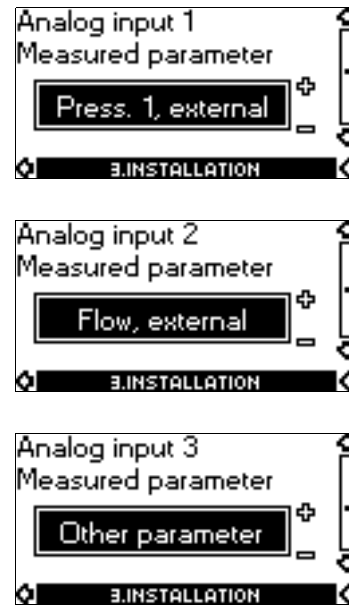

The analog inputs can be set to these measured parameters:

- Inlet pressure
- Diff. press., inlet
- Discharge press.
- Diff. press., outlet
- Diff. press., pump
- Press. 1, external
- Press. 2, external
- Diff. press., external
- Feed tank level
- Storage tank level
- Flow, pump
- Flow, external
- Liquid temp.
- Diff. temp., external
- Temperature 1
- Temperature 2
- Ambient temp.
- Other parameter.

The number of available displays depends on the functional module fitted in the motor. See below.

Function (terminal)	FM 300
Analog input 1, Measured parameter (4)	•
Analog input 2, Measured parameter (7)	•
Analog input 3, Measured parameter (14)	•

Analog input 1, 2 and 3

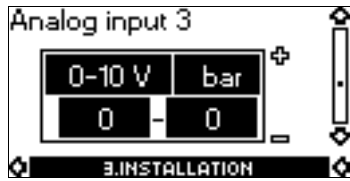
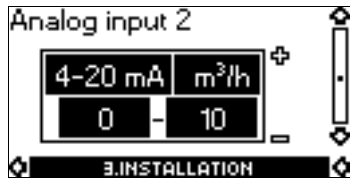

Select the following:

- Signal type (0.5 - 3.5 V, 0-5 V, 0-10 V, 0-20 mA or 4-20 mA). The FM 100 analog input only supports voltage signals.
- Measuring units for the measured parameters. Available measuring units:

Parameter	Possible units
Pressure	bar, m, kPa, psi, ft
Flow rate	m <sup>3</sup> /h, l/s, yd <sup>3</sup> /h, gpm
Temperature	°C, °F
Other	%

- Sensor measuring range.

**Note** The setting of the sensor is only relevant in the case of closed-loop operation.

The number of available displays depends on the functional module fitted in the motor. See below.

Function (terminal)	FM 300
Analog input 1 (4)	•
Analog input 2 (7)	•
Analog input 3 (14)	•

Pt100/1000 input 1 and 2, Function



The Pt100/1000 inputs can be set to these functions:

- Not active
- Feedback sensor
- Ext. setpoint infl. For further description, see section 27. *Bus signal*.
- Other function.

The number of available displays depends on the functional module fitted in the motor. See below.

Function (terminal)	FM 300
Pt100/1000 input 1, Function (17 and 18)	•
Pt100/1000 input 2, Function (19 and 18)	•

Pt100/1000 input 1 and 2, Measured parameter

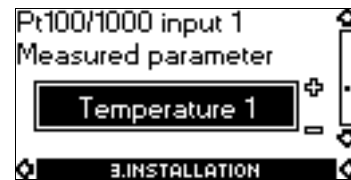

The Pt100/1000 inputs can be set to these measured parameters:

- Liquid temp.
- Temperature 1
- Temperature 2
- Ambient temp.
- DE bearing temp.
- NDE bearing temp.

The number of available displays depends on the functional module fitted in the motor. See below.

Function (terminal)	FM 100	FM 200	FM 300
Pt100/1000 input 1, Measured parameter (17 and 18)	-	-	•
Pt100/1000 input 2, Measured parameter (19 and 18)	-	-	•



## Operating range

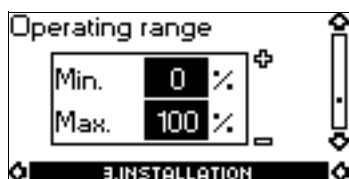

Set the operating range as follows:

- Set the min. speed within the range from fixed min. speed to user-set max. speed.
- Set the max. speed within the range from user-set min. speed to fixed max. speed.

The range between the user-set min. and max. speeds is the operating range. See fig. 31.

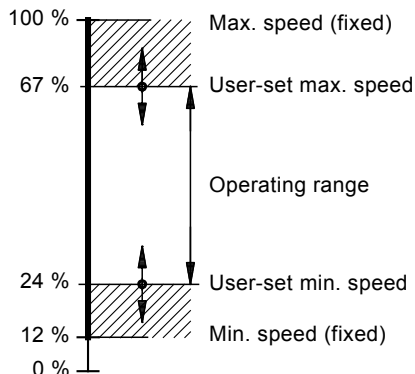
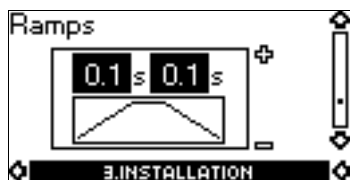

Fig. 31 Example of min. and max. settings

## Ramps



The setting of ramps is only relevant in the case of open-loop operation.

The ramps determine how quickly the motor can accelerate and decelerate, respectively, during start/stop or setpoint changes.

The following can be set:

- acceleration time, 0.1 to 300 s
- deceleration time, 0.1 to 300 s.

The times apply to the acceleration from stop to rated speed and the deceleration from rated speed to stop, respectively.

At short deceleration times, the deceleration of the motor may depend on load and inertia as there is no possibility of actively braking the motor.

If the power supply is switched off, the deceleration of the motor will only depend on load and inertia.

## Direction of rotation

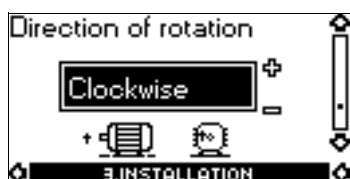

Select the desired direction of rotation of the motor when seen from the drive end:

- Clockwise
- Anti-clockwise.

The displayed direction of rotation will apply when the digital input for reversing is not active. See section *Digital input 1 and 2, Function*, page 37.

## Motor bearing monitoring



The motor bearing monitoring function can be set to these values:

- Active
- Not active.

When the function is set to "Active", a counter in the controller will start counting the mileage of the bearings.

*The counter will continue counting even if the function is changed to "Not active", but a warning will not be given when it is time for replacement.*

### Note

*When the function is changed to "Active" again, the accumulated mileage will again be used to calculate the replacement time.*

## Motor bearings



This function can be set to these values:

- Replaced
- Nothing done.

When the bearing monitoring function is active, the controller will give a warning indication when the motor bearings are due to be replaced. See section *Alarm*, page 33.

When the motor bearings have been replaced, confirm this action in the above display by pressing [OK].

## Standstill heating



The standstill heating function can be set to these values:

- Active
- Not active.

When the function is set to "Active", an AC voltage will be applied to the motor windings. The applied voltage will ensure that sufficient heat is generated to avoid condensation in the motor.

## 26.4 Grundfos GO Remote

The motor is designed for wireless radio or infrared communication with the Grundfos GO Remote.

The Grundfos GO Remote enables setting of functions and gives access to status overviews, technical product information and actual operating parameters.

The Grundfos GO Remote offers three different mobile interfaces (MI). See fig. 32:

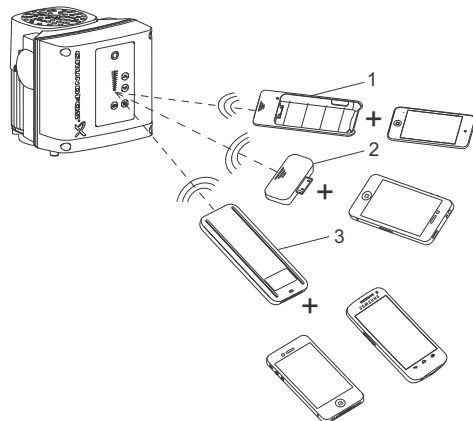

TM05 5383 3612

**Fig. 32** Grundfos GO Remote communicating with the motor via radio or infrared light

Pos.	Description
1	Grundfos MI 201 for Apple iPod
2	Grundfos MI 202 for Apple iPhone
3	Grundfos MI 301 for Android and iOS (Bluetooth communication is required).



### 26.4.1 Communication

When the Grundfos GO Remote communicates with the motor, the indicator light in the middle of the Grundfos Eye will flash green. See section 30. *Grundfos Eye*.

Communication must be established using one of these communication types:

- radio communication
- infrared communication.

#### Radio communication

Radio communication can take place at distances up to 30 metres. It is necessary to enable communication by pressing  or  on the motor control panel.

#### Infrared communication

When communicating via infrared light, the Grundfos GO Remote must be pointed at the motor control panel.

### 26.4.2 Navigation

Navigation can be done from the dashboard. See fig. 33.

## Dashboard

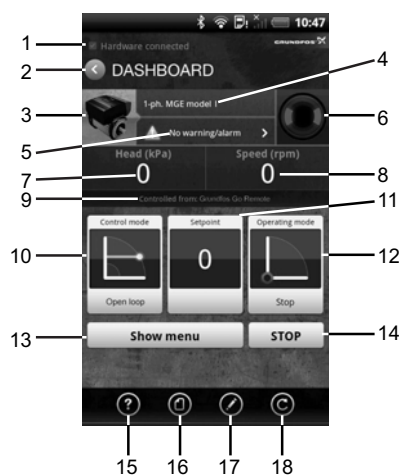

TM05 5609 3912

Fig. 33 Example of dashboard

Pos.	Description	Action
1	Connection indicator	This text appears when the Grundfos GO Remote app has connected to an MI 201, MI 202 or MI 301. If the hardware is not connected, it will not be possible to communicate with a Grundfos product.
2	Back button	Returns to the previous display.
3	Product information	Provides technical information about the product.
4	Product name	Name of the product communicating with the Grundfos GO Remote.
5	Alarms and warnings	Shows alarms and warnings.
6	Grundfos Eye	Shows the operating condition of the product.
7	Primary status value	Shows the primary status value.
8	Secondary status value	Shows the secondary status value.
9	Control source	Shows by which interface the product is controlled.
10	Control mode	Shows the control mode of the product.
11	Actual setpoint value	Shows the actual setpoint value.
12	Operating mode	Shows the operating mode.
13	Show menu	Gives access to other menus.
14	Stop	Stops the product.
<b>Tool bar</b>		
15	Help	The help function describes the menus making it easy for the user to change settings, etc.
16	Documentation	Gives access to installation and operating instructions and quick guides.
17	Report	Enables the creation of user-defined reports.
18	Update	Enables update of the Grundfos GO Remote app.

## 27. Bus signal

The motor enables serial communication via an RS-485 input. The communication is carried out according to the Grundfos GENIbus protocol and enables connection to a building management system or another external control system.

Via a bus signal, it is possible to remote-set motor operating parameters, such as setpoint and operating mode. At the same time, the motor can, via the bus, provide status information about important parameters, such as actual value of control parameter, input power and fault indications.

Contact Grundfos for further information.

Note
------

***If a bus signal is used, the number of settings available via the R100 or Grundfos GO Remote will be reduced.***

## 28. Priority of settings

The motor can always be set to operation at max. speed or to stop with the R100 or Grundfos GO Remote.

If two or more functions are enabled at the same time, the motor will operate according to the function with the highest priority.

**Example:** If, via the digital input, the motor has been set to max. speed, the motor control panel, the R100 or Grundfos GO Remote can only set the motor to "Manual" or "Stop".

The priority of the settings appears from the table below:

Priority	Start/stop button	R100, Grundfos GO Remote or control panel on motor	Digital input	Bus comm.
1	Stop			
2		Stop*		
3		Manual		
4		Max. speed*		
5			Stop	
6				Stop
7				Max. speed
8				Min. speed
9				Start
10			Max. speed	
11		Min. speed		
12			Min. speed	
13			Start	
14		Start		

\* "Stop" and "Max. speed" settings made with the R100, Grundfos GO Remote or on the motor control panel can be overruled by another operating-mode command sent from bus, for example "Start". If the bus communication is interrupted, the motor will resume its previous operating mode, for example "Stop", selected with the R100, Grundfos GO Remote or on the motor control panel.

## 29. External setpoint signal

It is possible to remotely set the setpoint by connecting an analog signal to the analog input terminals. The external signal may be (0.5 - 3.5 V, 0-5 V, 0-10 V, 0-20 mA, 4-20 mA).

### 29.1 Operation with sensor feedback

If fitted with a sensor, the pump can operate according to the control modes below:

- Constant pressure
- Constant differential pressure
- Constant temperature
- Constant differential temperature
- Constant flow rate
- Constant level
- Constant other value

If operation with sensor feedback is selected, the setpoint can be set externally within the range from the lower value of the sensor measuring range to the setpoint.

#### Example

Setpoint is to be the upper limit of the pressure sensor range. Operating mode is to be normal.

Control mode is to be constant pressure.

Operating range to be 25 % to 100 %.

Analog input as follows: (Grundfos GO)



(Analog input 2) Terminals 7 and 23

External setpoint function as follows: (Grundfos GO)

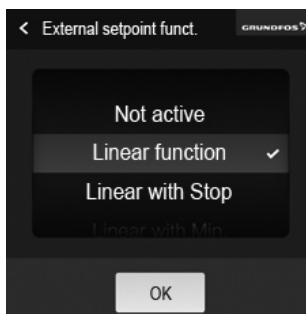

See Fig. 34

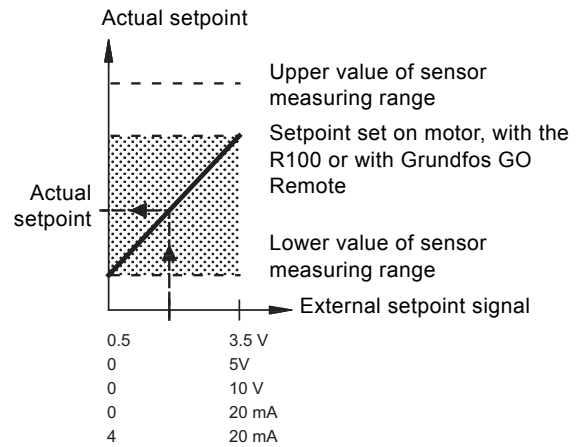

**Fig. 34** Relation between the actual setpoint and the external setpoint signal in operation with sensor feedback

**Example:** At a  $sensor_{min}$  value of 0 psi, a setpoint set of 50 psi and an external setpoint of 80 % (an 8 V analog signal if using an analog signal of 0-10 V), the actual setpoint will be as follows:

$$\begin{aligned}
 \text{Actual setpoint} &= (\text{setpoint} - \text{sensor}_{min}) \times \% \text{ external setpoint} + \text{sensor}_{min} \\
 &= (50 - 0) \times 80 \% + 0 \\
 &= 40 \text{ psi}
 \end{aligned}$$

TM05 9660 1013

TM05 9661 1013

TM05 5278 3512

### 29.2 Constant-curve operation

If constant-curve operation is selected, the setpoint can be set externally within the range from the min. speed to the setpoint.

Example

Setpoint is to be 100 %

Operating mode is to be normal

Control mode is to be constant curve

Operating range to be 25 % to 100 %

Analog input as follows: (Grundfos GO)



(Analog input 2) Terminals 7 and 23

External setpoint function as follows: (Grundfos GO)

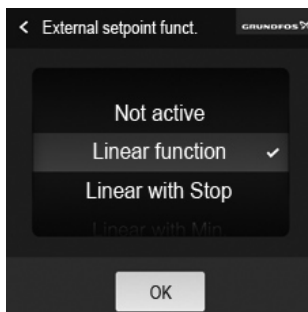

See Fig. 35

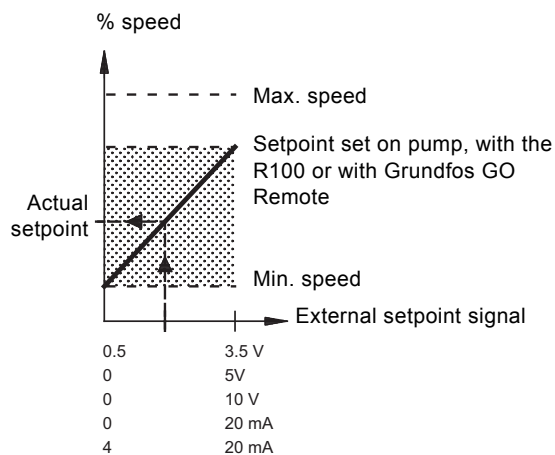

**Fig. 35** Relation between the actual setpoint and the external setpoint signal in constant-curve operation

**Example:** At a set setpoint of 65 % of  $n_{max}$ , and an external setpoint of 70 %, the actual setpoint is  $0.70 \times (65 - 12) + 12 = 49$  %.

TM05 9662 1013

TM05 9661 1013

TM05 5278 3512

### 30. Grundfos Eye

The operating condition of the motor is indicated by the Grundfos Eye on the motor control panel. See fig. 36, pos. A.

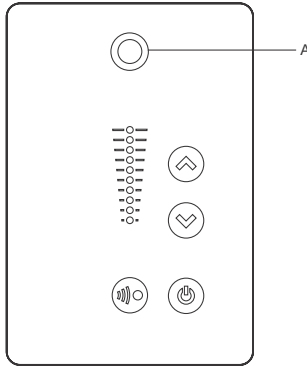

TM05 6993 1414

Fig. 36 Grundfos Eye





























































Grundfos Eye	Indication	Description
	No lights on.	<b>Power off.</b> Motor not running.
	Two opposite green indicator lights rotating in the direction of rotation of the motor when seen from the non-drive end.	<b>Power on.</b> Motor running.
	Two opposite green indicator lights permanently on.	<b>Power on.</b> Motor not running.
	One yellow indicator light rotating in the direction of rotation of the motor when seen from the non-drive end.	<b>Warning.</b> Motor running.
	One yellow indicator light permanently on.	<b>Warning.</b> Motor stopped.
	Two opposite red indicator lights flashing simultaneously.	<b>Alarm.</b> Motor stopped.
	The green indicator light in the middle flashes quickly four times.	<b>Remote control with the Grundfos GO Remote via radio</b> The motor is trying to communicate with the Grundfos GO Remote. The motor in question is highlighted in the Grundfos GO Remote display to inform the user of the location of the motor.
	The green indicator light in the middle flashes continuously.	When the motor in question is selected in the Grundfos GO Remote menu, the green indicator light in the middle will flash continuously. Press  on the motor control panel to allow remote control and data exchange via the Grundfos GO Remote.
	The green indicator light in the middle is permanently on.	<b>Remote control with the Grundfos GO Remote via radio</b> The motor is communicating with the Grundfos GO Remote via radio connection.
	The green indicator light in the middle flashes quickly while the R100 or Grundfos Go Remote is exchanging data with the motor. It will take a few seconds.	<b>Remote control with the R100 or Grundfos GO Remote via infrared light</b> The motor is receiving data from the R100 or Grundfos GO Remote via infrared communication.

### 31. Signal relays

The motor has two outputs for potential-free signals via two internal relays.

The signal outputs can be set to "Operation", "Running", "Ready", "Alarm" and "Warning".

The functions of the two signal relays appear from the table below:

Description	Grundfos Eye	Contact position for signal relays when activated					Operating mode
		Operation	Running	Ready	Alarm	Warning	
Power off.	 Off						-
Motor running in "Normal" mode in open or closed loop.	 Green, rotating						Normal, Min. or Max.
Motor running in "Manual" mode.	 Green, rotating						Manual
Motor in operating mode "Stop".	 Green, steady						Stop
Warning, but the motor is running.	 Yellow, rotating						Normal, Min. or Max.
Warning, but the motor is running in "Manual" mode.	 Yellow, rotating						Manual
Warning, but the motor was stopped via "Stop" command.	 Yellow, steady						Stop
Alarm, but the motor is running.	 Red, rotating						Normal, Min. or Max.
Alarm, but the motor is running in "Manual" mode.	 Red, rotating						Manual
Motor stopped due to an alarm.	 Red, flashing						Stop



## 32. Megging

**Caution**

*Megging of an installation incorporating MLE motors is not allowed, as the built-in electronics may be damaged.*

## 33. Technical data, single-phase motors

### 33.1 Supply voltage

Single-phase motors are available for the voltages below.

- 1 x 90-240 V - 10 %/+ 10 %, 50/60 Hz, PE or 30-300 VDC (power supply from a renewable-energy source).

Check that the supply voltage and frequency correspond to the values stated on the nameplate.

#### Recommended fuse size

Motor size [HP]	Min. [A]	Max. [A]
1.00	6	10
2.00	10	16

Standard as well as quick-blow or slow-blow fuses may be used.

### 33.2 Leakage current

Earth leakage current < 3.5 mA (AC supply).

Earth leakage current < 10 mA (DC supply).

The leakage currents are measured in accordance with EN 61800-5-1:2007.

## 34. Inputs/outputs

### Ground reference (GND)

All voltages refer to GND.

All currents return to GND.

### Absolute maximum voltage and current limits

Exceeding the following electrical limits may result in severely reduced operating reliability and motor life:

Relay 1:

Maximum contact load: 250 VAC, 2 A or 30 VDC, 2 A.

Relay 2:

Maximum contact load: 30 VDC, 2 A.

GENI terminals: -5.5 to 9.0 VDC or < 25 mADC.

Other input/output terminals: -0.5 to 26 VDC or < 15 mADC.

### Digital inputs (DI)

Internal pull-up current > 10 mA at  $V_i = 0$  VDC.

Internal pull-up to 5 VDC (currentless for  $V_i > 5$  VDC).

Certain low logic level:  $V_i < 1.5$  VDC.

Certain high logic level:  $V_i > 3.0$  VDC.

Hysteresis: No.

Screened cable: 20-16 AWG (0.5 - 1.5 mm<sup>2</sup>).

Maximum cable length: 1640 ft (500 m)

### Open-collector digital outputs (OC)

Current sinking capability: 75 mADC, no current sourcing.

Load types: Resistive or/and inductive.

Low-state output voltage at 75 mADC: Max. 1.2 VDC.

Low-state output voltage at 10 mADC: Max. 0.6 VDC.

Overcurrent protection: Yes.

Screened cable: 20-16 AWG (0.5 - 1.5 mm<sup>2</sup>).

Maximum cable length: 1640 ft (500 m)

### Analog inputs (AI)

Voltage signal ranges:

- 0.5 - 3.5 VDC, AL AU.
- 0-5 VDC, AU.
- 0-10 VDC, AU.

Voltage signal:  $R_i > 100$  k $\Omega$  at 77 °F (+25 °C).

Leak currents may occur at high operating temperatures. Keep the source impedance low.

Current signal ranges:

- 0-20 mADC, AU.
- 4-20 mADC, AL AU.

Current signal:  $R_i = 292$   $\Omega$ .

Current overload protection: Yes. Change to voltage signal.

Measurement tolerance: - 0/+ 3 % of full scale (max.-point coverage).

Screened cable: 20-16 AWG (0.5 - 1.5 mm<sup>2</sup>).

Maximum cable length: 1640 ft (500 m) (excl. potentiometer).

Potentiometer connected to +5 V, GND, any AI:

Use maximum 10 k $\Omega$ .

Maximum cable length: 328 ft (100 m).

### Analog output (AO)

Current sourcing capability only.

Voltage signal:

- Range: 0-10 VDC.
- Minimum load between AO and GND: 1 k $\Omega$ .
- Short-circuit protection: Yes.

Current signal:

- Ranges: 0-20 and 4-20 mADC.
- Maximum load between AO and GND: 500  $\Omega$ .
- Open-circuit protection: Yes.

Tolerance: - 0/+ 4 % of full scale (max.-point coverage).

Screened cable: 20-16 AWG (0.5 - 1.5 mm<sup>2</sup>).

Maximum cable length: 1640 ft (500 m)

**Pt100/1000 inputs (PT)**

Temperature range:

- Minimum -22 °F (-30 °C) (88 Ω/882 Ω).
- Maximum 356 °F (+180 °C) (168 Ω/1685 Ω).

Measurement tolerance: ± 2.7 °F (1.5 °C).

Measurement resolution: < 0.54 °F (0.3 °C).

Automatic range detection (Pt100 or Pt1000): Yes.

Sensor fault alarm: Yes.

Screened cable: 20-16 AWG (0.5 - 1.5 mm<sup>2</sup>).

Use Pt100 for short wires.

Use Pt1000 for long wires.

**LiqTec sensor inputs\***

Use Grundfos LiqTec sensor only.

Screened cable: 20-16 AWG (0.5 - 1.5 mm<sup>2</sup>).

**Power supplies (+5 V, +24 V)****+5 V:**

- Output voltage: 5 VDC - 5 %/+ 5 %.
- Maximum current: 50 mADC (sourcing only).
- Overload protection: Yes.

**+24 V:**

- Output voltage: 24 VDC - 5 %/+ 5 %.
- Maximum current: 60 mADC (sourcing only).
- Overload protection: Yes.

**Digital outputs (relays)**

Potential-free changeover contacts.

Minimum contact load when in use: 5 VDC, 10 mA.

Screened cable: 20-12 AWG (0.5 - 2.5 mm<sup>2</sup>).

Maximum cable length: 1640 ft (500 m)

**Bus input**

Grundfos GENIbus protocol, RS-485.

Screened 3-core cable: 20-16 AWG (0.5 - 1.5 mm<sup>2</sup>).

Maximum cable length: 1640 ft (500 m)

**35. Other technical data****EMC (electromagnetic compatibility)**

EN 61800-3.

Residential areas, unlimited distribution, corresponding to CISPR 11, class B, group 1.

Industrial areas, unlimited distribution, corresponding to CISPR 11, class A, group 1.

Contact Grundfos for further information.

**Enclosure class**

Standard: NEMA 3 TEFC.

**Insulation class**

F.

**Torques**

Terminal	Thread size	Max. torque ft-lb [Nm]
L1, L2, L3, L, N	M4	1.73 (2.35)
NC, C1, C2, NO	M2.5	0.37 (0.5)
1 to 26 and A, Y, B	M2	0.37 (0.5)

**35.1 Sound pressure level**

Motor [hp (kW)]	Max. speed stated on nameplate [rpm]	Speed [rpm]	Sound pressure level ISO 3743 [dB(A)]	
			1-phase motors	3-phase motors
0.33 - 1.00 (0.25 - 0.75)	2000	1500	38	38
		2000	42	42
	4000	3000	53	53
		4000	58	58
	5900	4000	58	58
		5900	68	68
1.5 (1.1)	2000	1500		38
		2000		42
	4000	3000	53	53
		4000	58	58
	5900	4000	58	58
		5900	68	68
2.0 (1.5)	2000	1500		
		2000		
	4000	3000	57	57
		4000	64	64
	5900	4000	58	58
		5900	68	68
3.0 (2.2)	2000	1500		
		2000		
	4000	3000		57
		4000		64
	5900	4000		58
		5900		68

The grey fields indicate that the motor is not yet available in this MLE motor range, but is available in the previous MLE motor range.

**36. Disposal**

This product or parts of it must be disposed of in an environmentally sound way:

1. Use the public or private waste collection service.
2. If this is not possible, contact the nearest Grundfos company or service workshop.

The waste battery should be disposed of through the national collection programs. If in doubt, contact your local Grundfos company.

Subject to alterations.

## 1. Installation in the USA and Canada

### 1.1 Radio communication

#### For USA

This device complies with part 15 of the FCC rules and RSS210 of IC rules.

Operation is subject to the following two conditions:

- This device may not cause interference.
- This device must accept any interference, including interference that may cause undesired operation of the device.

#### Pour le Canada

#### Communication radio

Ce dispositif est conforme à la partie 15 des règles de la FCC et aux normes RSS210 de l'IC.

Son fonctionnement est soumis aux deux conditions suivantes:

- Ce dispositif ne doit pas provoquer de brouillage préjudiciable.
- Il doit accepter tout brouillage reçu, y compris le brouillage pouvant entraîner un mauvais fonctionnement.

### 1.2 Identification numbers

#### For USA

Grundfos Holding A/S

Contains FCC ID: OG3-RADIOM01-2G4.

#### For Canada

Grundfos Holding A/S

Model: RADIOMODULE 2G4

Contains IC: 10447A-RA2G4M01.

#### Pour le Canada

#### Numéros d'identification

Grundfos Holding A/S

Modèle: RADIOMODULE 2G4

Contient IC: 10447A-RA2G4M01.

### 1.3 Electrical connection

#### 1.3.1 Conductors

See section 6.2 *Cable requirements*, page 7.

#### 1.3.2 Torques

Maximum tightening torques for the terminals can be found in section *Torques*, page 50.

#### 1.3.3 Line reactors

Maximum line reactor size must not exceed 1.5 mH.

#### 1.3.4 Fuse size/circuit breaker

If a short-circuit occurs, the pump can be used on a mains supply delivering not more than 5000 RMS symmetrical amperes, 600 V maximum.

Motor size	Fuse size	Circuit breaker type/model
1.00 to 2.00 HP	25 A	25 A / inverse time

#### Fuses

When the motor is protected by fuses, they must be rated for 480 V. Maximum sizes are stated in the table above.

Motors up to and including 2.00 HP require class K5 UR fuses.

#### Circuit breaker

When the pump is protected by a circuit breaker, this must be rated for a maximum voltage of 480 V. The circuit breaker must be of the "inverse time" type.

The interrupting rating (RMS symmetrical amperes) must not be less than the values stated in the table above.

#### 1.3.5 Overload protection

Degree of overload protection provided internally by the drive, in percent of full-load current: 102 %.







**GRUNDFOS Kansas City**

17100 West 118th Terrace  
Olathe, Kansas 66061  
Phone: (913) 227-3400  
Fax: (913) 227-3500

[www.grundfos.us](http://www.grundfos.us)

**GRUNDFOS Canada**

2941 Brighton Road  
Oakville, Ontario L6H 6C9 Canada  
Phone: +1-905 829 9533  
Telefax: +1-905 829 9512

[www.grundfos.ca](http://www.grundfos.ca)

**GRUNDFOS México**

Boulevard TLC No. 15  
Parque Industrial Stiva Aeropuerto  
C.P. 66600 Apodaca, N.L. México  
Phone: 011-52-81-8144 4000  
Fax: 011-52-81-8144 4010

[www.grundfos.mx](http://www.grundfos.mx)

<b>98620964</b> 0514
ECM: 1128447

© Copyright Grundfos Holding A/S

The name Grundfos, the Grundfos logo, and be think innovate are registered trademarks owned by Grundfos Holding A/S or Grundfos A/S, Denmark. All rights reserved worldwide.