

CM Booster Self-Priming

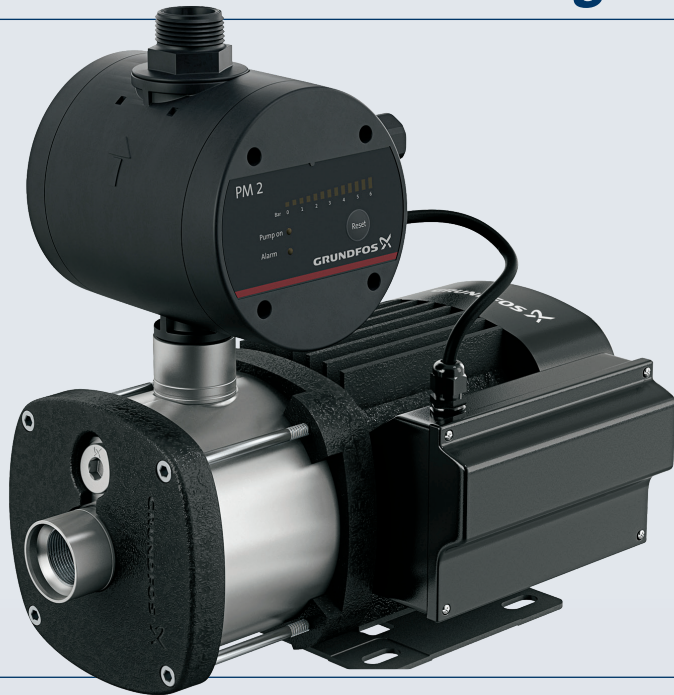

The Grundfos CM Booster Self-Priming is a compact booster pump designed for domestic and light industrial use. The booster unit consists of a robust multistage centrifugal pump and a generator friendly PM1 or PM2 pressure manager. The pressure manager allows the pump to start and stop automatically according to demand and protects the pump from dry running. The CM Booster Self-Priming is the perfect solution if you are struggling with insufficient mains pressure, and can also be used with above or below ground water sources.



Features

Self-priming

With a suction lift of up to 8 metres (self-priming up to 4 metres) the CM Booster Self-Priming is ideal for pressurising water from above or below ground water sources.

Robust design

All wetted parts are made from high quality, corrosion resistant stainless steel to ensure the longest life possible.

User-friendly interface

The pump features a user-friendly interface with LED indicators displaying power status, pump running, alarm indication and pressure indication (excluding CMB-SP 1-36).

Protective functions

The pump incorporates a range of protective features such as; dry run protection, thermal overload protection, cycling alarm and maximum continuous operation time - 30 mins (excluding CMB-SP 1-36) to protect the pump and ensure a long life.

Adaptability

The CM Booster Self-Priming can be adapted to the individual installation thanks to the adjustable start pressure.

Easy installation

The booster unit is a compact solution, which makes it suitable for most installations. Simply connect the inlet and outlet, and you have a fully operational booster unit.

Integrated non-return valve

Non-return valve for backflow prevention.

Applications

- Mains boosting
- Household water supply
- Boosting from above ground water tanks
- Boosting from below ground water sources e.g. below ground tank/dam
- Light industrial use



CM Booster Self-Priming

Performance

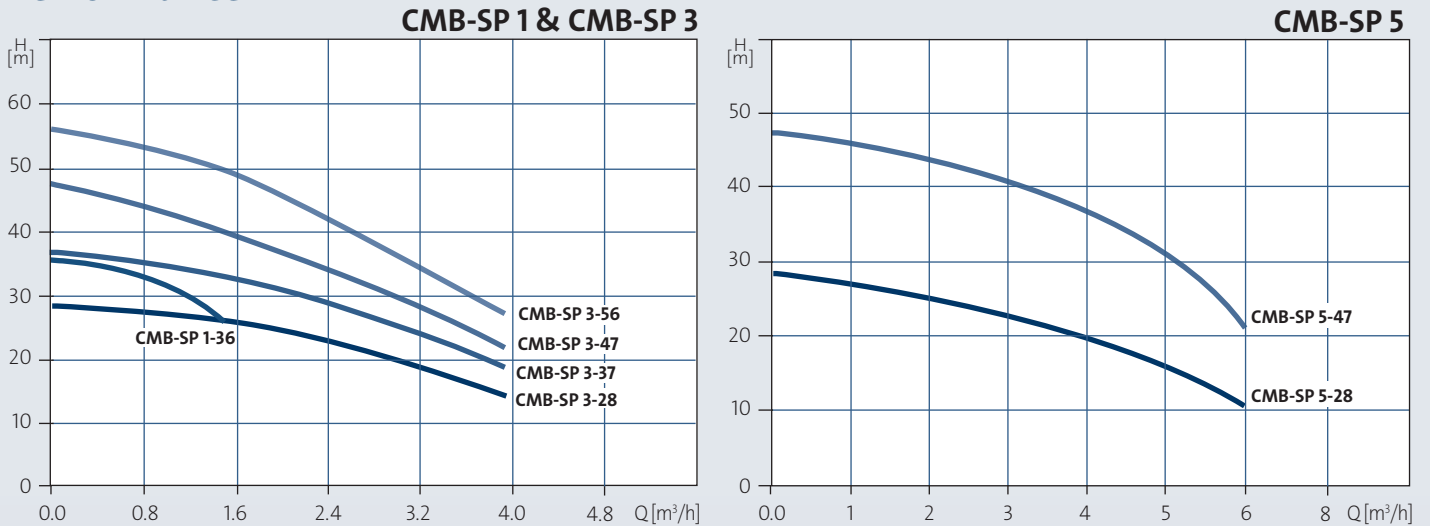

Operating Conditions

System pressure

Max. 10 bar

Liquid temperature

0 °C to +60 °C

Ambient temperature

Max. +55 °C

Relative air humidity

Max. 95 %

Dimensions

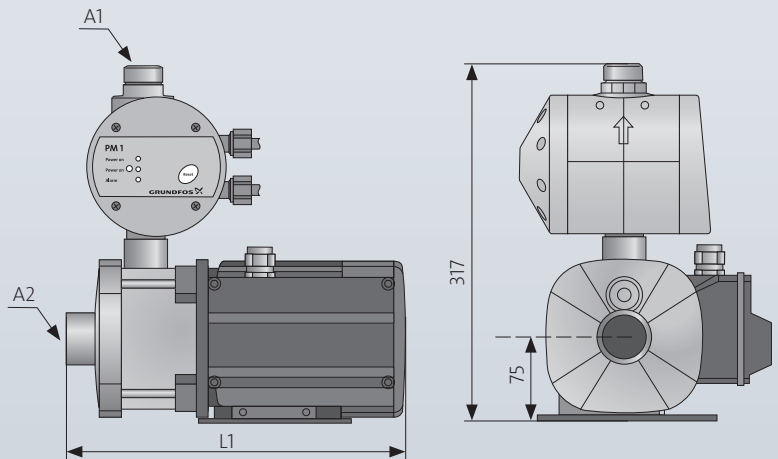

Technical Data

Mains voltage

1 x 240 V, 50 Hz

Enclosure class

IP55

Insulation class

F

Sound pressure level

50-60 dB

Start/stop frequency

Max. 100 per hour

Approvals and markings

CE

Model	Part Number	Power (kW)	Dimensions			Weight (kg)
			A1	A2	L1 (mm)	
CMB-SP 1-36	98507562	0.5	1" F	1" F	377	14.1
CMB-SP 3-28	98507627	0.5	1" F	1" F	377	13.7
CMB-SP 3-37	98507628	0.5	1" F	1" F	377	14.1
CMB-SP 3-47	98507629	0.5	1" F	1" F	413	14.4
CMB-SP 3-56	98507630	0.67	1" F	1" F	453	16.4
CMB-SP 5-28	98507635	0.5	1" F	1 1/4" F	377	13.7
CMB-SP 5-47	98507636	0.9	1" F	1 1/4" F	453	16.9