



GREEN

INSTALLATION & USERS GUIDE

IMPORTANT



This product must be installed by a licensed electrician. This product must be installed according to the AS3000 – Australian Wiring Standards.

DANGER



Danger to life due to high voltage AC

Always ensure all electricity sources are appropriately isolated when installing this piece of equipment.

DANGER

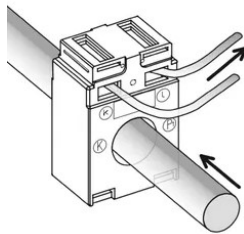

Electric Shock Risk with CT's

CT's must be fitted to insulated cables only. Ensure CT is terminated into the device before clamping onto cables.

Inside the package

- 1 x CATCH Diverter
- 1 x Current Transformers
- 1 x Mounting Plate

Specifications

Operational Voltage	230VAC
Operational Frequency	50Hz
Maximum AC Load	4.8kW (20A)
Load Types	Resistive Only
Control Method	Zero Cross
Diversion Start	100W
Max A/C Cable Size	6mm ²
CT lead length	1m
IP Rating	IP2X
Operating Temperature range	-20°C to +45°C
Battery Compatible	Yes
Size	100W x 110H x 50D (mm)
Standards Conformity	AS/NZS3100, AS/NZS CISPR 32:2015

CATCH DIVERTER Installation

IMPORTANT:

- Maximum load allowed to be connected to HW terminal is 4.8kW.
- Cable sizing must be chosen based on the AS3000 wiring standard.
- The Diverter must be protected from weather. The recommended installation location is inside the meter box.

CLEARANCE

The clearance specifications below are recommended clearances. If the clearances cannot be achieved the diverter will de rate if needed to accommodate the installation environment.

IMPORTANT		<p>Case temperature can reach 60°C.</p> <p>Ensure the diverter is not placed next to anything that can be affected by moderate temperatures.</p>
------------------	--	---

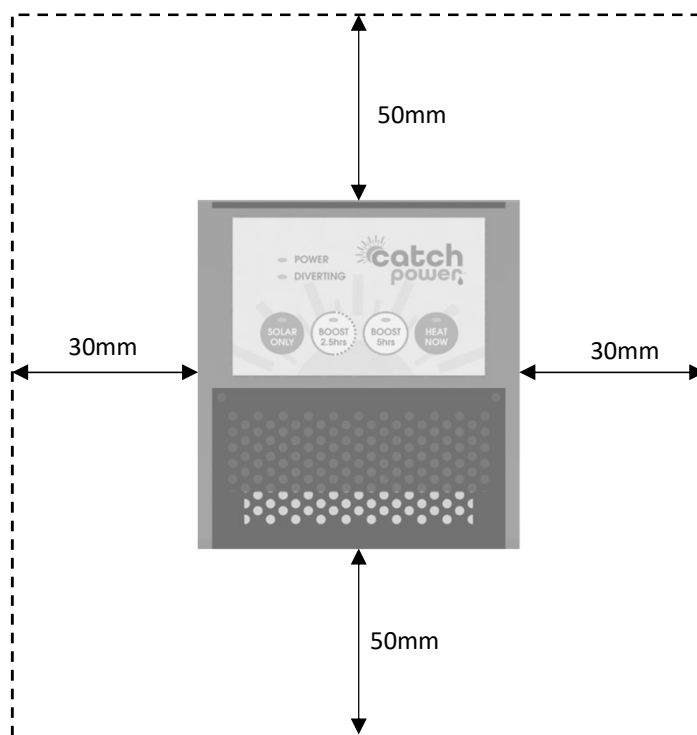

1 – INSTALL MOUNTING PLATE

The clearance specifications above are recommended clearances. If the clearances cannot be achieved the diverter will derate if needed to accommodate the installation environment.

1.1 – Detach mounting plate from unit.

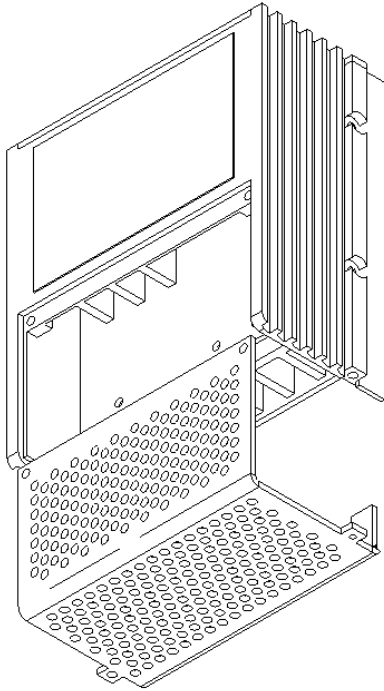

Remove the 4 screws from the bottom guard and remove the guard.

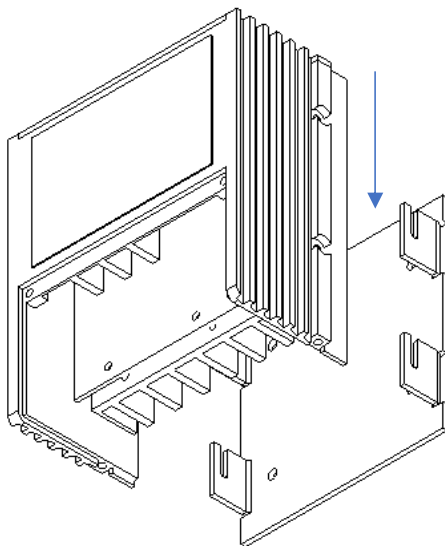

Slide the mounting plate down towards the bottom of the unit then pull it out as shown.

1.2 - Fix the mounting plate to a flat surface using the four bolt holes on the plate.

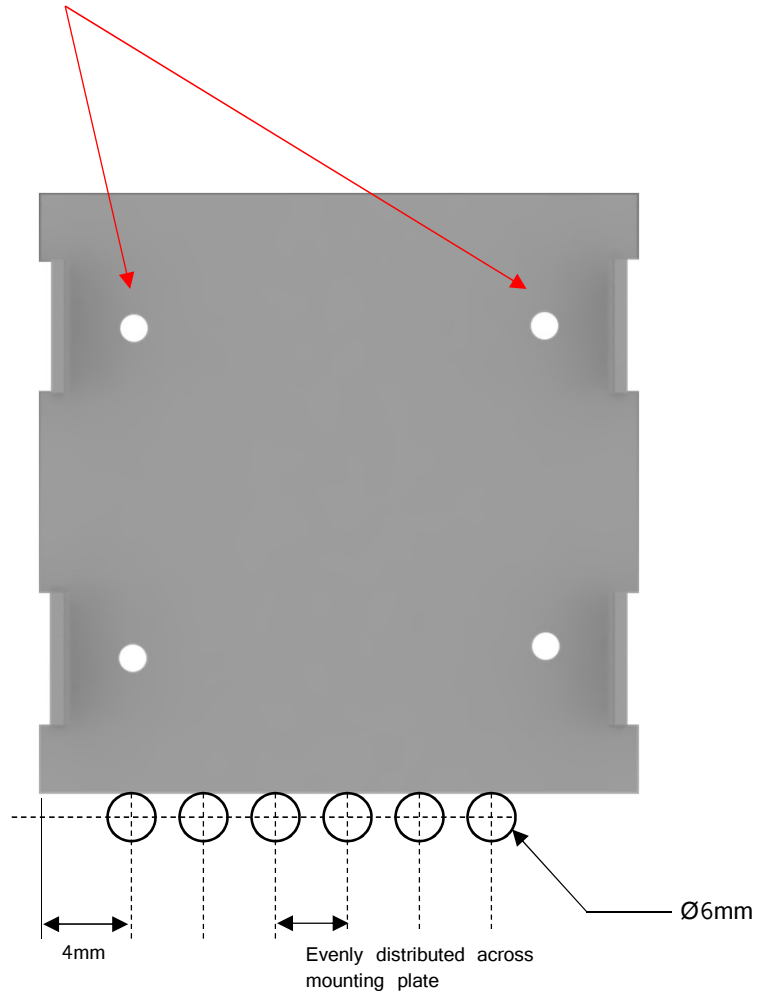

1.3 - Drill cable entry holes based on dimensions shown.

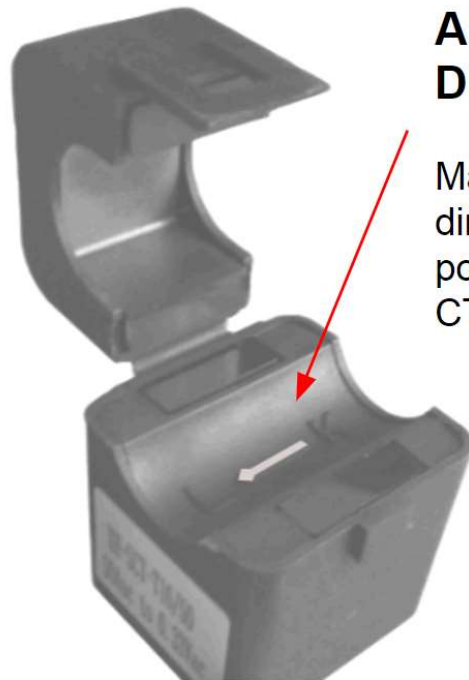

ALL CT's ARE DIRECTIONAL.

Make sure you know which direction the arrow is pointing before placing the CT.

BEFORE YOU BEGIN:

- The arrows next to the CT's in the wiring diagram represent the arrows on the inside of the CT's.
- Matching the CT's to the correct phase is critically important special care must be taken to ensure this happens.
- NEVER disconnect CT's from diverter while they are wrapped around a current carrying conductor.
- If Controlled Load Off Peak is not available leave the Off Peak connection empty.
- Multiple wires can be put through the CT, as long as all currents are in the same direction.
- **Some electrical jurisdictions do not allow switches in the Off Peak circuit, if this is your case then do not connect the off peak circuit.**

2 – Attach Device to Mounting Plate and complete wiring

Wire the device into the domestic installation as shown.

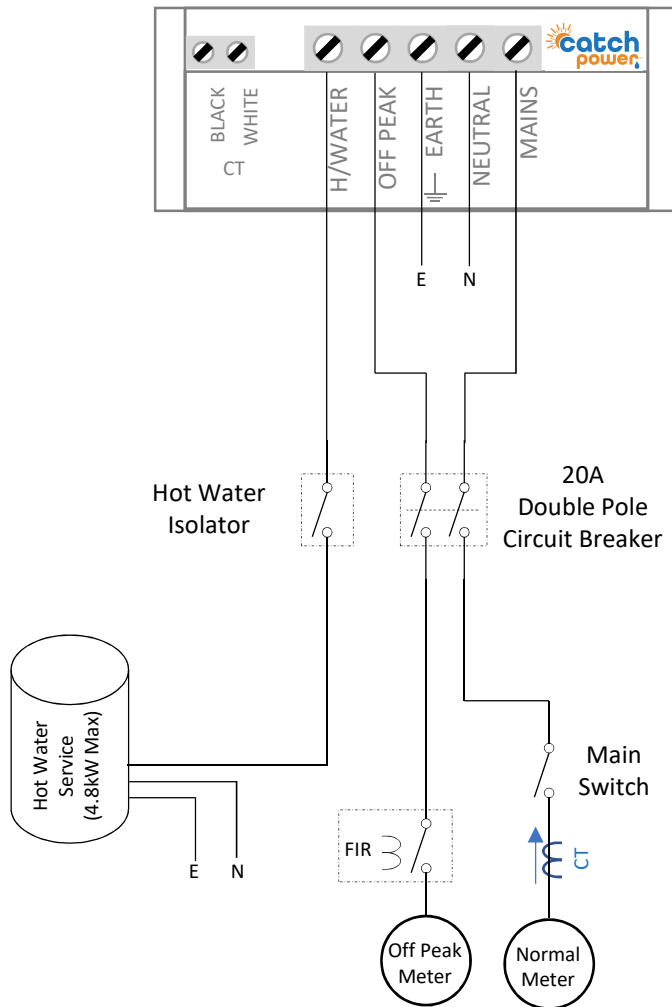

- All electrical work must be carried out in accordance with AS3000.
- Hot water isolator is not required if 20A double pole breaker clearly label as hot water.
- **Off Peak MUST be on the same phase as the MAINS terminal.**

2.1 – Cable termination into the device

It is important to ensure cable termination is neat and tidy into the terminal blocks to ensure there is no risk of active conductors migrating to earthing screws.

The recommended cable profile is show below.

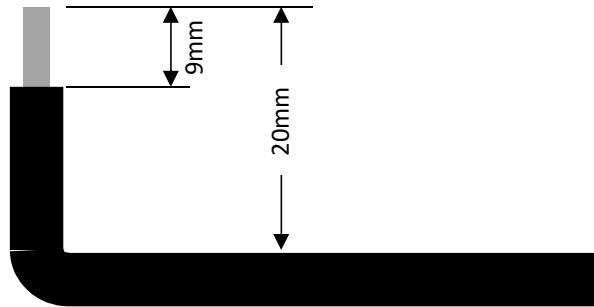

- Ensure cables are position so that no long term load is applied to terminal blocks.
- Ensure all terminal block screws are screwed in tight, even the ones that are not used.

2.2 – Connect the current transformer

IMPORTANT



It is vitally important the CT's are pointing in the right direction.

DANGER

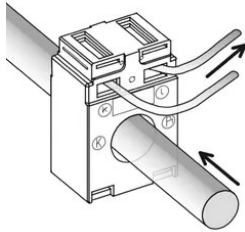

Electric Shock Risk with CT's

CT's must be fitted to insulated cables only. Ensure CT is terminated into the device before clamping onto cables.

Mains

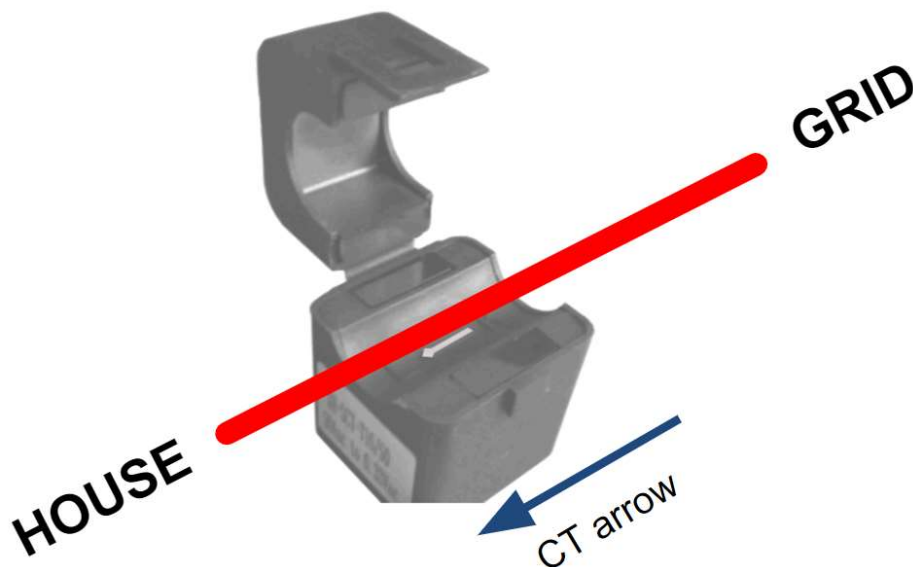

** CT arrow points in same direction as current flow

2.3 – Replace Bottom Guard

- Replace the bottom guard ensuring all cables are not touching the guard.
- Replace all screws ensuring the tooth washers are used for the screws exposed at the top of the guard.

3 – How to Control Catch

Catch has been designed with simplicity in mind. The interface has only 4 buttons.

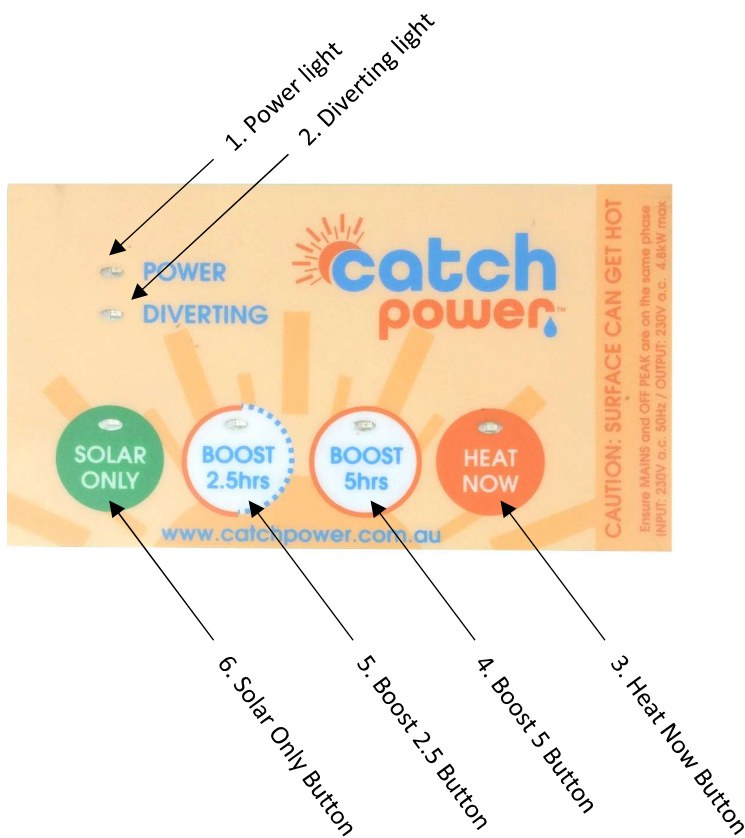

1. Power light

The power light indicates the unit has power to it and is ready to operate. Most of the time this led will be solid green.

If you see the power led flashing on and off it means the unit is restricting power delivery to the hot water because it is getting hot.

The device getting hot is not an indication of a problem, the small form factor means there will be times the unit needs to slow down because it is getting hot.

1. Diverting light

The diverting light indicates how much energy is being sent to the hot water service. The faster the diverting light is flashing the more energy is being sent to the hot water.

If the diverting light is solid green it means the unit is as at 100%, which means Catch is sending as much power as the hot water element can handle.

If the diverting light is off and you see a very short pulse of light every few seconds it means the hot water service has hit temperature and the hot water thermostat has shut the element off.

Understanding the CATCH buttons

Each button on the control console represents a different mode of operation. You change modes by gently pressing on the round circle that represents each button. Catch will let you know if it has changed modes by the green LED lighting up on the button you have just pressed.

3. Heat Now Button

The Heat Now mode is entered into by pressing the Heat now button.

The Heat Now mode is used to get your hot water heated as soon as you press the button. In this mode the device will first check to see if it can you power from the Off Peak line. If the off peak is not installed or is not available then it will use normal mains power.

Once the hot water service hits thermal cut off CATCH will move out of Heat now mode and go back into Boost 5hrs mode.

Heat Now Lock mode can be entered by pressing the Heat Now button a second time. Catch will tell you it is in Heat Now Lock mode by flashing the led on the Heat Now Button on and off.

When Catch is in Heat Now Lock mode CATCH stay in Heat Now mode until you manually change it to another mode.

4. Boost 5 Button

The Boost 5Hrs mode means Catch will attempt to use 5hs of Off Peak energy each day as well as the excess solar energy to heat hot water.

5. Boost 2.5 Button

The Boost 2.5Hrs mode means Catch will attempt to use 2.55hs of Off Peak energy each day as well as the excess solar energy to heat hot water.

6. Solar Only Button

The Solar Only mode means Catch will not use any Off Peak energy to heat hot water. The only energy that will be sent to the hot water service is solar energy that would have otherwise been exported to the grid.