



RACE - R PRO GP



SHARK HELMETS

FOR 30 YEARS, SHARK HAS BEEN COMMITTED TO:

- + INNOVATION
- + PERFORMANCE
- + SAFETY

TO THE BENEFIT OF ALL RIDERS.



<https://us.shark-helmets.com>

RACE-R PRO GP

30TH ANNIVERSARY SPOILER DOT/22-05



RACE-R PRO GP
RED 30TH ANNIVERSARY
SPOILER DOT/2205
HE8572D RRK

STICKERS INCLUDED
IN THE BOX



RACE-R PRO GP

30TH ANNIVERSARY SPOILER DOT/22-05



RACE-R PRO GP
BLACK 30TH ANNIVERSARY
SPOILER DOT/2205
HE8572D KKP

STICKERS INCLUDED
IN THE BOX

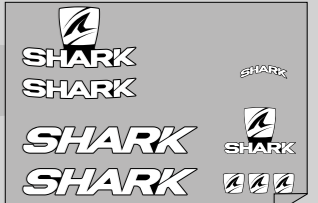

RACE-R PRO GP

30TH ANNIVERSARY SPOILER DOT/22-05



RACE-R PRO GP
WHITE 30TH ANNIVERSARY
SPOILER DOT/2205
HE8572D WWK

STICKERS INCLUDED
IN THE BOX

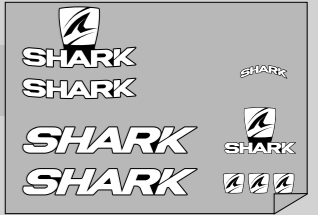



RACE-R PRO GP

RACING #1 SPOILER DOT/22-05



RACE-R PRO GP
RACING #1
SPOILER DOT/2205
HE8571D KMA

STICKERS INCLUDED
IN THE BOX

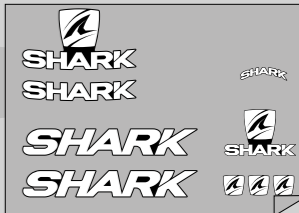

RACE-R PRO GP

LORENZO WINTER TEST



RACE-R PRO GP
LORENZO WINTER TEST
SPOILER DOT/2205
HE8570D KAB

STICKERS INCLUDED
IN THE BOX

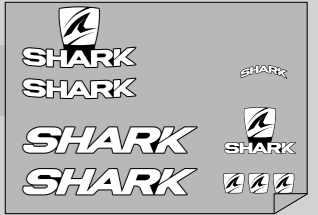

RACE-R PRO GP

LORENZO WINTER TEST



RACE-R PRO GP
LORENZO WINTER TEST
SPOILER DOT/2205
HE8570D KAR

STICKERS INCLUDED
IN THE BOX

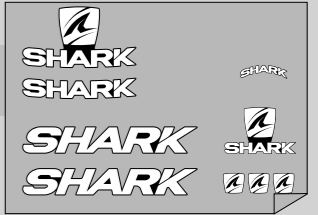

RACE-R PRO GP

MATTE REDDING WINTER TEST



RACE-R PRO GP
MATTE REDDING WINTER TEST
SPOILER DOT/2205
HE8574D KKR

STICKERS INCLUDED
IN THE BOX

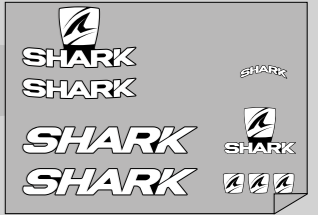

RACE-R PRO GP

RACE-R PRO GP

The Race-R PRO GP is the latest version of the iconic Race-R PRO model, flagship of SHARK's Racing line, which has been an integral part of over 200 victories at world speed championships*. Built for the track, this high-end, widely recognizable version has been fitted with an aerodynamic spoiler designed specifically for racing.

The high-performance aerodynamic profile, achieved through close collaboration between SHARK's Research & Development teams and our MotoGP racers, is the successful result of state-of-the-art testing based on CFD (Computational Fluid Dynamics) simulations.

Objective: surface analysis and optimized fluid flows along the helmet, yielding the highest level of aerodynamic efficiency at top speeds.

Tested under arduous racing conditions and approved by our best riders, this helmet represents the perfect blend of a unique design, safety, uncompromising aerodynamics, technological innovations, highest-grade finishes and a premium packaging.

RACE-R PRO GP: A TECHNICALLY-SOPHISTICATED AERODYNAMIC PROFILE

• Aerodynamic spoiler:

The Race-R Pro GP has been equipped with a spoiler designed to optimize aerodynamic performance when traveling at very high speed**. This aerodynamically-refined profile has been enhanced by applying breakthrough technologies in the field of CFD (Computational Fluid Dynamics). Developed in a wind tunnel through collaboration with our most demanding racers, this spoiler produces less aerodynamic drag, eliminates undesirable vibration effects and offers the rider greater stability along with a tweaked top speed.

• Chin guard profile designed for racing:

This design serves to reduce the exposed surface area of the helmet in back of the fairing.
Objective: Lower the aerodynamic drag.

RACE-R PRO GP: COMFORT, STABILITY AND ERGONOMICS



1 Two-tone, high-tech «Alveotech» lining fabric featuring the Sanitized® label.
This Sanitized® treatment ensures antimicrobial efficiency to prevent the propagation of bacteria when perspiring. It guarantees a cool contact over long periods for extra comfort during a strenuous ride.

2 Wrap-around and breathable neck protection
Specially designed for optimal acoustic insulation.

3 «Dual use», anti-fog breath guard with added functionalities: a fixed piece + a snap-on removable piece
Objectives:
• Adapt to all types of weather conditions (cold, wind, etc.)
• Block out background noise
• Minimize turbulence.

4 New technology used to cut out «3D morpho» cheek contours
Providing maximum comfort and support.

5 Shape memory ear pads that serve to muffle noise due to acoustic vibrations.



* In-house study conducted on the Grands Prix Moto GP, Moto 2, Moto 3 and WSBK, WSSP between 2012 and 2018.
** Extreme speed beyond the authorized legal limit: reserved for track trials.

RACE-R PRO GP: AN ULTRA-SAFE HELMET

1 A shell built with a multi-axial fibre structure.

2 Multi-density, EPS (Expanded Polystyrene) shell: Optimal damping at each impact zone.

3 Chin guard fitted with a removable, variable airflow anti-pollution filter.

4 Dual-density, EPU (Expanded Polyurethane) chin guard: Material designed above all to absorb shocks reverberating around the chin guard.

5 Ergonomic visor grip For improved handling and easy opening.



6 High-strength visor comes with an Optical Class 1 rating and variable thickness (ranging from 4.2 mm to 2.8 mm) without introducing any visual distortion. Treated to prevent scratches and fogging. System installed to enable quick visor disassembly.

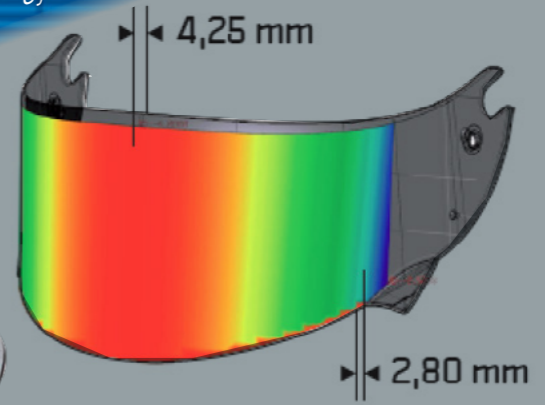

7 «Quick Spoiler Safety System»: Allows ejecting the spoiler in the event of a fall to limit the effects of secondary shocks and thereby guarantee the rider's optimal safety.



RACE-R PRO GP: FINISH ULTRA PREMIUM



Visor mechanics and hardware with a top-quality coated finish and «SHARK Racing Division» laser engraving.



Double-D ring strap made of a coated titanium. Magnetic buckle to ensure perfect stability.



Custom-designed neck protection featuring a laser marking.

COMPREHENSIVE PACKAGING

- An exclusively designed «Racing Division» helmet box and casing
- The Race-R PRO GP model
- The official «SHARK Racing Division» bag used by our MotoGP racers
- A «dark smoke» tinted, anti-scratch / anti-fog visor (VZ10022PFU)
- SHARK Helmets racing stickers



SPECIFICATIONS



Constructed from multiaxial glass fibre



Visor with anti-scratch treatment on the outside and anti-fog on the inside



Anti-scratch visor



Double-D ring strap



«3D morpho» cheeks



2 shell sizes: Optimal morphological adjustment



Enhanced comfort for riders wearing glasses



Quick visor disassembly system



Washed on a delicate or cold cycle in its protective net



Slot reserved for SHARKTOOTH®