



Welch[®] Rietschle Thomas

Owners Manual For Dry Vacuum Pumps Models 2562 & 2567

Contents: Safety Information
Installation
Operation
Maintenance
Trouble-Shooting
Specification
Dimensional Drawings
Application Information
Exploded Parts Listings
Warranty



WARNING

Not recommended for pumping acid, base or organic vapors or gases.

WARNING

Be sure to properly identify intake and discharge before using pump.

Welch Rietschle Thomas
7301 North Central Avenue
Skokie, IL 60077
Phone: (847) 676-8800
Fax: (847) 677-8606
E-Mail: welchvacuum@thomasind.com
Web-Page: www.welchvacuum.com

Part No. 67-1356R1.3
Printed in the U.S.A

CONTENTS

SECTION	PAGE
1. Safty Information	3
2. Installation	4
3. Operation	7
4. Maintenance	7
5. Trouble Shooting	8
6. Specification	8
7. Dimensional Drawings	10
8. Application Information	11
9. Exploded Parts Listings	12-15
10. Warranty	16

PLEASE READ BEFORE OPERATION

While reading your manual, please pay close attention to areas labeled **WARNING AND CAUTIONS**.
The description of each is found below.

WARNING
Warnings are given where failure to observe instruction could result in injury or death to people

CAUTION
Cautions are found where failure to observe the instruction should result in damage to the equipment, associated equipment and process.

These units conform to the SI International system of units of measurement.
The following symbols (with recommendations of IEC1010) of warning will be found on the pump.

Caution - refer to accompanying documents



Caution - hot surface



Caution - risk of electrical shock



WARNING
Motor includes a self resetting thermal cut-out and the pump could restart without actuation under fault condition.

Section 1: SAFTY INFORMATION

Read and understand the following information and instructions included with your Welch Dry Vacuum Pumps before using. This information is for your safety and to prevent damage to the pumps.

1.1 CAUTION: To Prevent Injury...

1.1a Never operate this product if it has a damaged cord or plug. If it is not working properly, has been dropped, damaged or has fallen in water, please return the product to a Welch service center for examination and repair.

1.1b Keep cord away from heated surfaces.

1.1c Never block any air openings or place it on a soft surface where the openings may be blocked. The air openings are for ventilation of the motor inside the housing. Keep all air openings free of lint, dirt and other foreign objects.

1.1d Never drop or insert fingers or any other object into any openings.

1.1e Do not operate this product where oxygen is being administered.

1.1f This pump is thermally protected and can automatically restart when the protector resets. Always disconnect power source before servicing.

1.1g Wear safety glasses or goggles when operating this product.

1.1h Do not use any tools or attachments without first determining maximum air pressure for that tool or attachment.

1.1i All electrical products generate heat. To avoid serious burns never touch unit during or immediately after operation.

1.1j Be sure to properly identify intake and discharge before using pump. See section 2.5.

1.2 CAUTION: To reduce risk of electrical shock...

1.2a Do not disassemble. Disassembly or attempted repairs if accomplished incorrectly can create electrical shock hazard. Refer servicing to qualified service agencies only.

1.2b Unit is supplied with a three-pronged plug. Be sure to connect pump to a properly grounded outlet only.

1.3 WARNING: To reduce risk of electrocution...

1.3a Do not use this product in or near area where it can fall or be pulled into water or other liquids.

1.3b Do not reach for this product if it has fallen in to liquid. Unplug immediately.

1.3c Use indoors only.

1.4 DANGER: To reduce risk of explosion or fire...

1.4a Do not use this pump in or near explosive atmospheres where aerosol (spray) products are being used.

1.4b Do not pump anything other than atmospheric air.

1.4c Do not pump anything other than liquids or vapors with this product or use in or near area where flammable or explosive liquids or vapors may exist.

1.4d Do not use this product near flames.



WARNING
Failure to observe the above safety precautions could result in severe bodily injury, including death in extreme cases.

Section 2: INSTALLATION

2.1 Introduction

This manual has been compiled not only for the care and maintenance of the Welch Dry Vacuum pump now in your possession, but as a helpful reference and guide to prevent many problems which can occur if used improperly.

2.2 Unpacking

Carefully remove the Dry Vacuum pump from the shipping case and unfasten and remove wooden skid. Preserve all paperwork for future reference. If damage has occurred from shipment a claim must be filed with the carrier immediately. Preserve the shipping carton for inspection by the carrier. If you are required to communicate with your dealer or Welch Vacuum be sure to include your order numbers for quick identification. Do not return the pump to the factory without first calling for a returned goods number.

2.3 Pump Mounting

Rubber feet are attached to the pump. Rubber feet are excellent for applications involving a semi-flexible surface such as a bench top; they help to isolate noise and eliminate creeping. All models of Dry Vacuum Pumps should be mounted in a horizontal plane.

2.4 Pump Location

The pressure/vacuum pump should be located preferably in a clean, dry and well-ventilated area. Please be sure not to block the ventilation ports located on the motor housing. The pump should be placed where the surrounding temperature remains between 10°C and 40°C (50°F and 104°F). Always check to insure the location choice is protected from direct or indirect moisture contact. Welch recommends that the pump be installed at the highest point within the system to prevent possible water condensate from entering the pump. The pump should be located as closely to its system in order to utilize it most efficiently.



WARNING

Don't pump flammable or explosive gases or vapors or operate this pump in an atmosphere containing flammable or explosive gases or vapors.

2.5 Intake and discharge provisions

The intake provision is a hose barb which accepts 3/8" ID Hose (Welch part no. 331030-5 is a 5 ft length of 3/8" ID vacuum hose). A silencer is supplied for the exhaust.



WARNING

Bursting Hazard- use on exhaust port the silencer or air handling parts suitable for pressures not less than 100 PSIG

Be sure to call Welch technical service prior to start-up at (847) 676-8800 ext. 1 if you have any questions.

2.6 Electrical Power

2.6a Power source review

Review the power source and the motor rating to be sure they agree in voltage, phase and frequency. Serious damage may occur to the motor if it is connected to an improper voltage. All Welch pumps must be grounded. Grounding reduces the risk of electrical shock in the event of an electrical short circuit. The plug must be plugged into an outlet properly grounded. Consult your local electrical codes if you have doubts.

2.6b Overload Protection

The motor manufacturer makes motor thermal overload protection available as an aid to minimizing motor failure. Overload protection is a standard feature on both 50 and 60 Hz single-phase motors. The motors have automatic overload protection. Automatic reset protection is designed to reset itself after a predetermined cooling period. If the fault to the drive remains unaltered, the motor will cycle on and off until fault is corrected.



WARNING
The motor is thermally protected and will automatically restart unexpectedly when the overload device resets.

2.6c Identification Symbols

○ OFF (Power)
| ON (Power)

2.6d Grounding Instructions

This product should be grounded. In the event of an electrical short circuit, grounding reduces the risk of electric shock by providing an escape wire for the electric current. This product is equipped with a cord having a grounding wire with a grounding plug. The plug must be plugged into an outlet that is properly installed and grounded in accordance with all local codes and ordinances.



DANGER
Improper installation of the grounding plug can result in a risk of electrical shock.

If repair or replacement of the cord or plug is necessary, do not connect the grounding wire to either flat blade terminal. The wire with insulation having an outer surface that is green with or without yellow stripes is the grounding wire.

Check with a qualified electrician or serviceman if the grounding instructions are not completely understood, or if in doubt as to whether the product is properly grounded. Do not modify the plug provided; if it will not fit the outlet, have the proper outlet installed by a qualified electrician.

This product is for use on a nominal 120V circuit, and has a grounding plug that looks like the plug illustrated in Sketch A in Figure #1. A temporary adapter, which looks like the adapter illustrated in sketches Band C, may be used to connect this plug to a 2-pole receptacle as shown in sketch B if a properly grounded outlet is not available.

The temporary adapter should be used only until a properly grounded outlet (Sketch A) can be installed by a qualified electrician. The green colored rigid ear, lug, etc. extending from the adapter must be connected to a permanent ground such as a properly grounded outlet box cover. Whenever the adapter is used, it must be held in place by a metal screw.

The adapter shown in Figure B and Figure C is not acceptable in Canada.

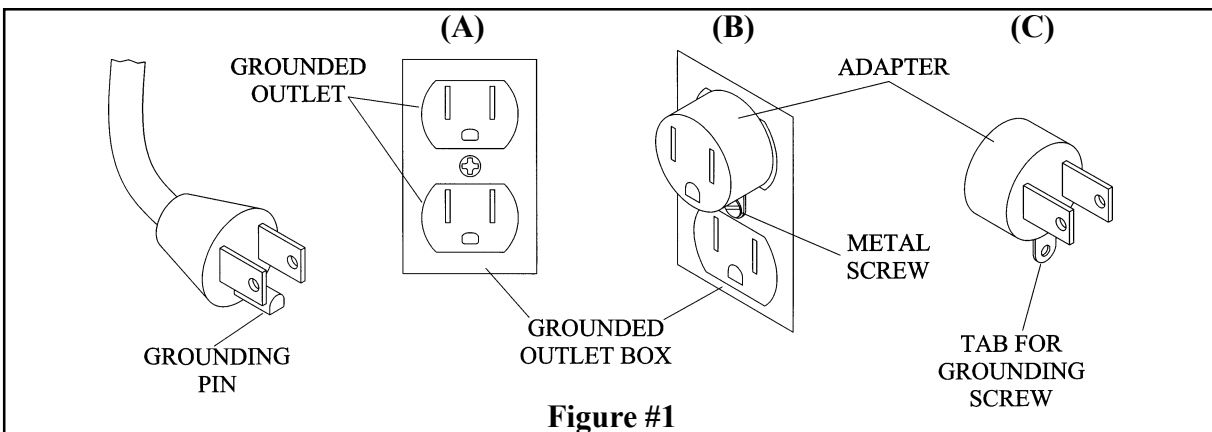

Figure #1

2.6e Extension Cords

If necessary to use an extension cord, use a 3-wire extension cord that has a 3-blade grounding plug, and a 3-slot receptacle that will accept the plug on the product. Make certain your extension cord is in good condition. Make certain your extension cord wire size is not less than 18 guage for 25 feet, 16 guage for 50 feet, and 14 guage for 100 feet. An undersized cord will cause a drop in line voltage resulting in loss of power and overheating. If in doubt, use the next heavier cord. The smaller the guage number, the heavier the cord.

2.7 Vacuum Connections

All Dry Vacuum Pumps come with intake and discharge hose barbs which accept 3/8" ID rubber pressure/vacuum hose. Hose clamps should be used to hold the hose in place. Since all four models operate in the viscous flow regime, the small diameter of the hose will generate minimal conductance loss. For best results, Welch recommends the length of the tubing between the pump and the chamber be kept as small as possible.

2.8. Vacuum Gauges

Typical in the rough vacuum range, a dial vacuum gauge is used to measure pressure in mm, Hg or inches of Hg. The dial vacuum gauge gives negative pressure – that is pressure below atmospheric. The reference point for the vacuum gauge is atmospheric pressure.

Please keep in mind that atmospheric pressure tends to vary from day to day. As a result of variability, the dial vacuum gauge will indicate slightly different maximum vacuum readings from day to day.

2.9 Traps

2.9a The need for a Trap

The pumps will handle humid air. All wetted aluminum parts are treated for corrosion protection from moisture. All other wetted parts are stainless steel. If there is a chance liquid may be drawn from the process under evacuation, Welch recommends a liquid trap be placed between the process and the pump. A simple liquid trap is a filtering flask.

When a heavy load of water vapor is evolved from the vacuum process, a cold trap is recommended to help prevent damage to the pump mechanism. The cold trap, immersed in a suitable Dewar flask, is installed so that the water vapor may come in contact with the surfaces of the trap and condense. Commonly used refrigerants are liquid nitrogen or dry ice and acetone or alcohol. Dry ice provides sufficient cooling to freeze out most heavy water vapor loads. A variety of cold traps are available from Welch.

The symptom of a high water vapor load is if you have droplets coming out of the exhaust port. If you see droplets of water, Welch recommends you use a cold trap to capture the water before entering the pump or dilute the water vapor stream by adding dry nitrogen to the gas flow. Please call our customer service department for additional information at (847) 676-8800 Ext. 1.

2.9b The care of a Trap

When using a cold trap the refrigerant should be maintained at a high level in the flask to keep the trap at a uniformly low temperature. If the trap is re-warmed it may allow re-evaporation of the condensate. The refrigerant add tube on the liquid nitrogen trap should not be obstructed as the refrigerant boil-off can produce dangerously high pressures. If the trap becomes saturated it should be disconnected from the system, drained and cleaned. An increase in pressure in the vacuum system will normally indicate that the trap has become saturated. To clean the trap, remove the trap from the system and allow the trap to warm up and rinse off the condensate with a suitable solvent in a fume hood. Thoroughly clean and dry the trap before reinstalling into the system.

Section 3: OPERATION

3.1 Starting Procedures

3.1a Starting a Welch Dry Vacuum Pump

Before attaching the pump to a system it is well to familiarize yourself with the function and action of the pressure vacuum pump that you have acquired. Review the power requirements as described in Section 2.6. Welch recommends running the pump for a few minutes to warm up before use. The warm-up improves the pumps ability to handle humid air.

3.1b. Cleanliness

Take every precaution to prevent foreign particulates from entering the pump. Particulates will damage the pump's performance. If you find that particulates will come off the process during evacuation, a particulate trap in the foreline will work. A simple, inexpensive trap may be made by placing glass wool in a glass or plastic tube. Screens must be inserted to hold the glass wool in place.



WARNING

The pump is not recommended for pumping acid, base or organic vapors or gases. Serious damage to the pump will shorten the pump's service life. In addition, pumping flammable vapors or gases can lead to serious safety hazard leading to fire or explosion.

3.2 Leak Detection

The importance of eliminating all leaks in a vacuum system is obvious. The pump must remove this added volume of leaked gas to maintain the desired vacuum. Leaks for these pumps can be located by slightly pressuring the system and painting the suspected area with a thick soap solution. Escaping air will produce soap bubbles.

3.3 Operating Pressure Range

Models 2562 and 2567 Dry Vacuum Pumps are designed to be run from atmospheric to their maximum vacuum level on the intake side. Consult the Specification Table in the back of this manual for the ratings for your specific model.

3.4 Shutdown Procedures

After use, Welch recommends the pump be run for about 2 minutes disconnected from the vacuum process. The air pumped through the mechanism will purge out water vapor or droplets of water condensate that may have formed on the inside of the pump. This purge of the pump mechanism helps prevent corrosion.

Section 4: MAINTENANCE

Welch dry pressure\vacuum units are 100% oil-free. The pump employs a non-lube piston and cylinder. No maintenance is necessary for the bearings. All bearings are sealed and permanently lubricated. Lubrication should not be attempted. The units are built for continuous duty operation with the quietness and durability of a diaphragm, but with piston performance.

Section 5: TROUBLESHOOTING

5.1 Vacuum Problems

Leakage, contamination and unusual outgassing are the general causes of problems with poor vacuum. To operate at maximum efficiency a system must be thoroughly clean. If the system is completely clean and free from leaks, and unwarranted vacuum problems still exist, the pump should be checked. A simple criterion for the condition of the pump is the determination of its maximum vacuum capability. This can be accomplished by blocking of the intake and reading the vacuum level on the gauge (See Section 2.8).

5.2 Troubleshooting Guide

Poor Pumping Speed	Poor Vacuum	Loud Unit	Possible Cause	Corrective Action
X	X	X	Damaged Valves	Replace flapper valves
X	X	X	Debris in Valves	Remove debris and check for valve damage
X	X	X	Damaged Gaskets	Replace gaskets
X	X	X	Loose Head Screws	Tighten head Screws
X	X		Loose Fittings	Tighten fittings

Section 6: SPECIFICATIONS

6.1 Pump Specifications Chart

Welch Model	2562	2567
Free Air Displacement		
CFM (L/min)@60Hz	2.3 (65)	4.5 (128)
M ³ /hr (L/min)@50Hz	3.4 (57)	6.4 (107)
Ultimate Press., Torr (mbar)	7.5 (10)	60 (80)
Max Vacuum, in. Hg	29.6	27.6
Motor Horsepower	1/3	1/3
Tubing Needed I.D. in.	3/8	3/8
Weight, lbs. (kg)	16.5 (7.5)	16.5 (7.5)
Catalog Number Wired for 115V, 60Hz, 1 Ph with IEC/USA line cord to IEC with North American Plug	2562B-01	2567B-01
Catalog Number Wired for 220V, 50Hz, 1 Ph with IEC/Schuko line cord to IEC with Schuko Plug	2562C-02	2567C-02
Catalog Number Wired for 100V, 50/60Hz, 1 Ph with IEC/JIS line cord to IEC with North American Plug	2562C-05	2567C-05

6.2 Pumping Speed Curves

Pumping Speed for 2562B-01

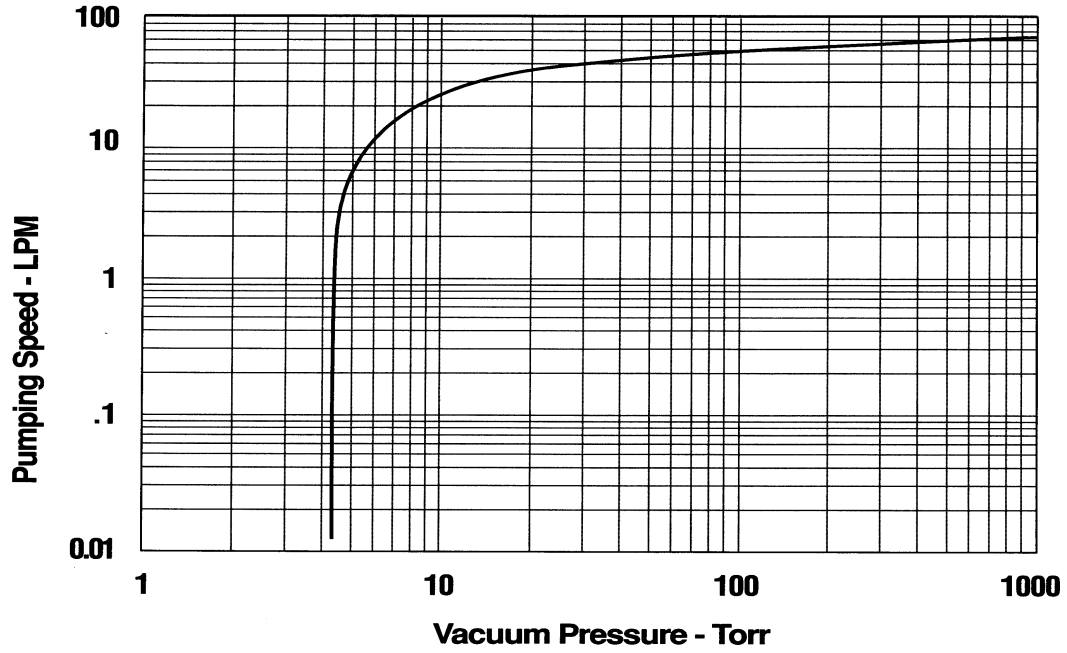

Pumping Speed for 2567B-01

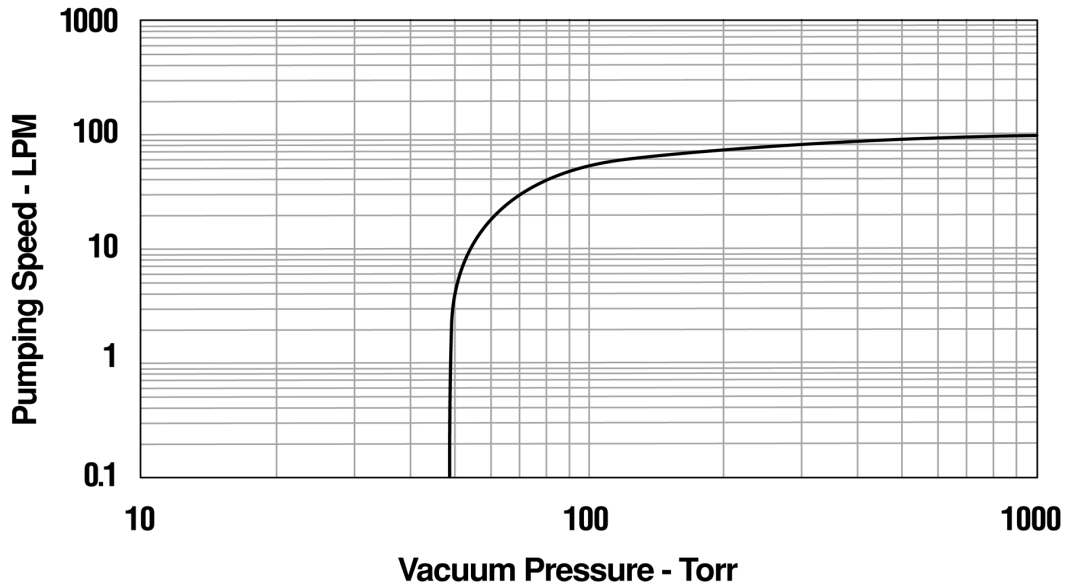

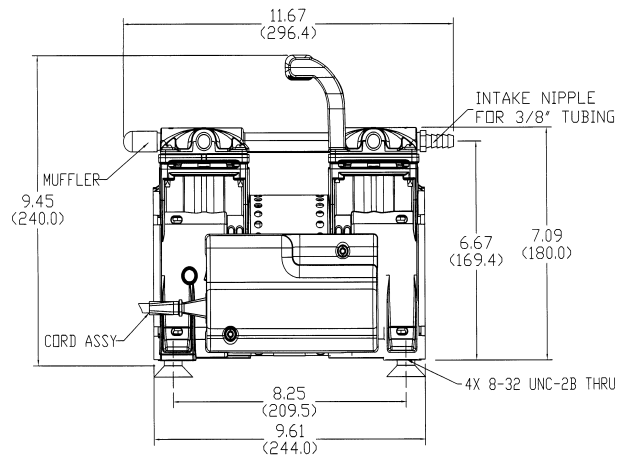
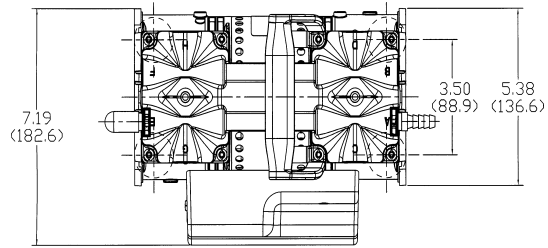

Model 2562

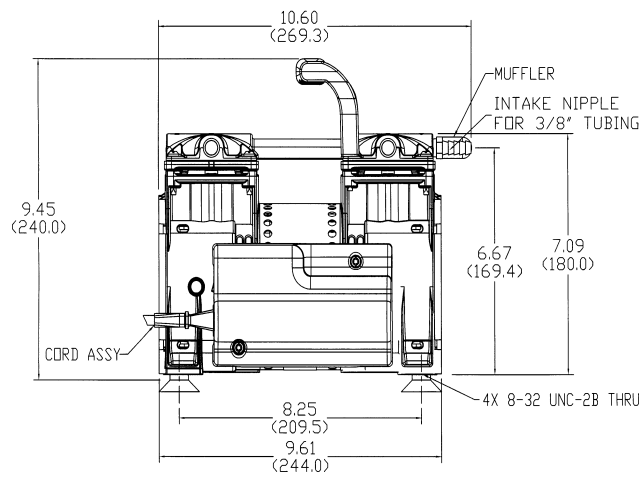
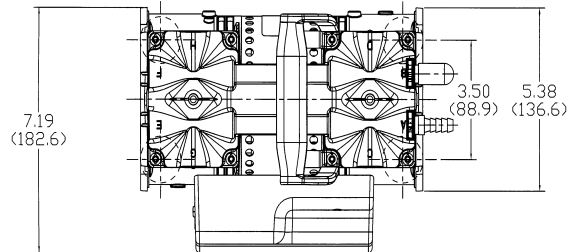

Model 2567

8. APPLICATION INFORMATION

A. Vacuum System For Cell Harvesting : Models 2562B-50, 2562C-50, 2562C-56, 2567B-50, 2567C-50 & 2567C-56

A-1. System Components

QTY	2562	2567	DESCRIPTION
1	2562B-01	2567B-01	Pump, 115V, 60Hz, 1Ph
or 1	2562C-02	2567C-02	Pump, 230V, 50/60Hz, 1Ph
or 1	2562C-05	2567C-05	Pump, 100V, 50/60Hz, 1Ph
1	61-3278	61-3278	Glass Jar Assembly w/o Orifice
	71-1271	71-1271	Filter Jar
1	71-1295	71-1295	Vacuum Gauge
or 1	61-3494	61-3494	Vacuum Gauge (kPa for Japan)
1	62-0381	62-0381	Male Tee
1	62-0372	62-0372	Female Hex Coupling
1	62-0354	62-0354	Hose Barb
1	1412C	1412C	Silencer
1	61-5072	61-5072	Variable Orifice
1	41-3175	41-3175	Gasket (used to provide seal between orifice and Teflon coated cap)



A-2. System Operation

The vacuum systems provides high throughput flow which allows up to 96+ sample systems to be handled. The attached inlet trap is provided to inhibit the accidental ingestion of liquid into the pump.

Vacuum level is preset at 26”Hg when the inlet is plugged with a rubber stopper. The vacuum gauge provided allows you to check the vacuum level; that is pressure below atmospheric. The reference point for the vacuum gauge is atmospheric pressure. Please keep in mind, that atmospheric pressure tends to vary from day to day. As a result of this variability, the dial vacuum gauge will indicate slightly different maximum vacuum readings from day to day.

The preset vacuum level may be adjusted by opening or closing the orifice. A small leak through the orifice is provided to allow easy restart of the pump if you are turning the pump -off then immediately turning on as is found with some cell harvesting applications.

By turning clockwise the screw located on top of the orifice, the vacuum level can be dropped to as low as 26.7”Hg. The deeper vacuum is particularly useful for removing sticky or viscous substances. If you close the orifice, please keep in mind this will lead to restart problems if you are turning-off then immediately turning on the pump. If you encounter a restart problem after closing off the orifice, you will need to incorporate into your procedure bringing the cell harvester up to atmospheric prior to restarting of the pump.

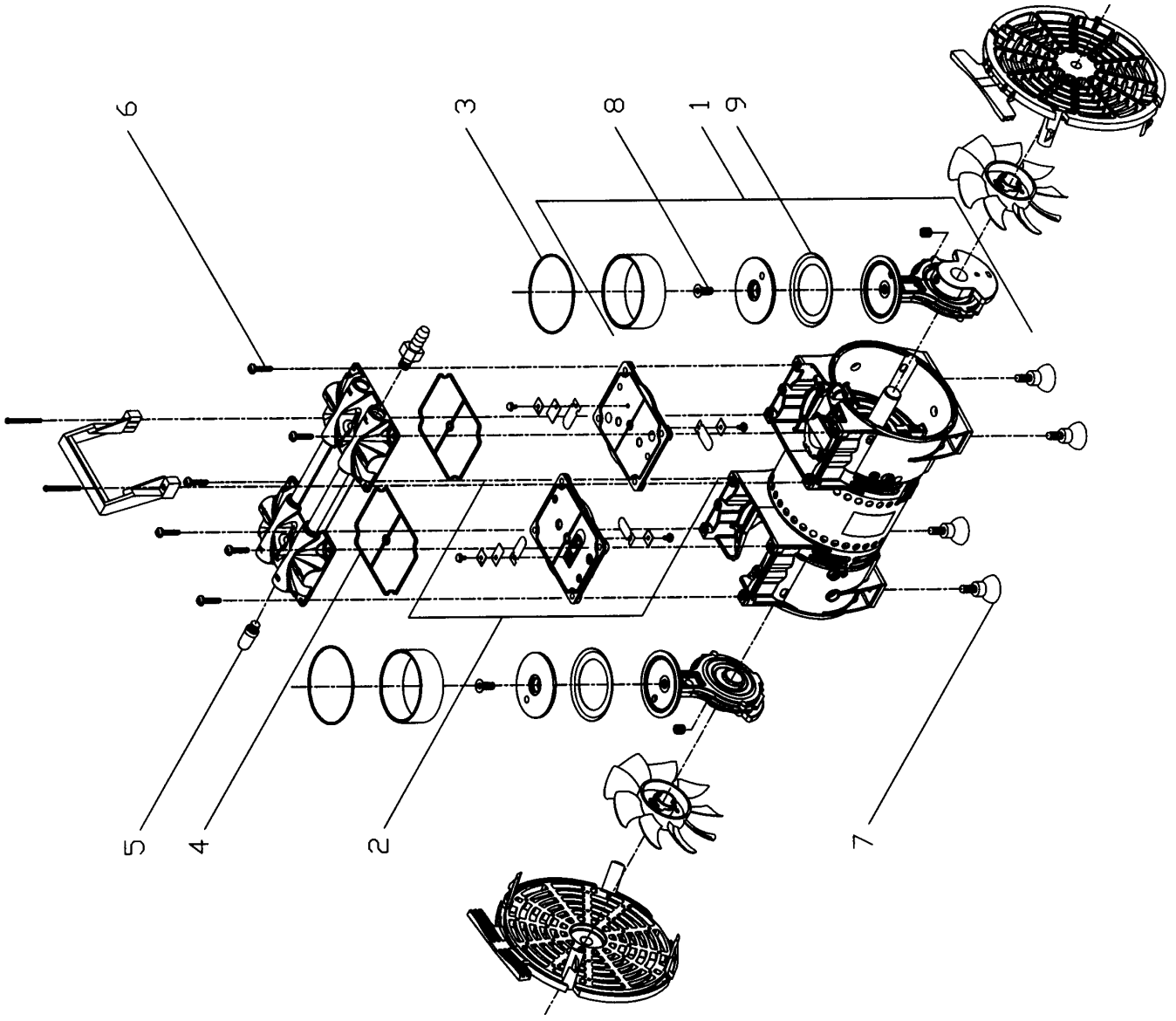

**PARTS LIST
MODEL 2562 VACUUM PUMP**

ITEM	QTY	PART NO.	DESCRIPTION	SERVICE KIT 2567K-03	SERVICE SEAL KIT 2567K-04	SERVICE FEET KIT 2500K-04
1	2	2567K-01	Connecting Rod Assembly	2	-	-
2	2	2567k-02	Valve Plate Assembly	2	-	-
3	2	62-1050	Cylinder O-Ring	2	2	-
4	2	62-1052	Valve Plate Gasket	2	2	-
5	1	1412C	Muffler	1	-	-
6	8	62-1051	Head Screw	8	-	-
7	4	66-0160	Feet, Suction Cup	-	-	4
8	2	62-1109	Retainer Hold Down Screw	-	2	-
9	2	62-1110	PTFE Piston Seal	-	2	-

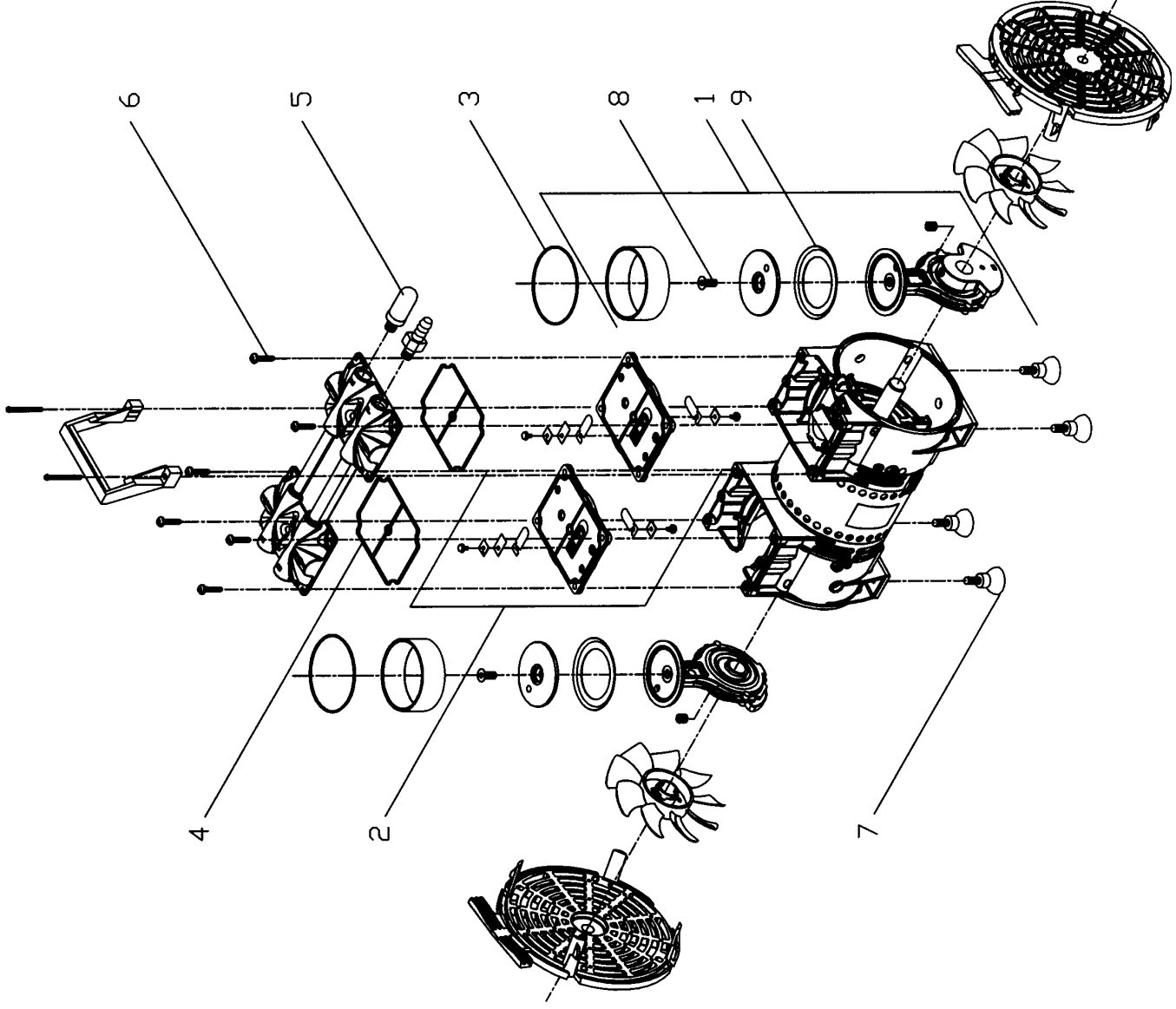

**PARTS LIST
MODEL 2567 VACUUM PUMP**

ITEM	QTY	PART NO.	DESCRIPTION	SERVICE KIT 2567K-03	SERVICE SEAL KIT 2567K-04	SERVICE FEET KIT 2500K-04
1	2	2567K-01	Connecting Rod Assembly	2	-	-
2	2	2567k-02	Valve Plate Assembly	2	-	-
3	2	62-1050	Cylinder O-Ring	2	2	-
4	2	62-1052	Valve Plate Gasket	2	2	-
5	1	1412C	Muffler	1	-	-
6	8	62-1051	Head Screw	8	-	-
7	4	66-0160	Feet, Suction Cup	-	-	4
8	2	62-1109	Retainer Hold Down Screw	-	2	-
9	2	62-1110	PTFE Piston Seal	-	2	-

WARRANTY

This Welch Vacuum product is warranted to be free from defects in material and workmanship. This liability of Welch Vacuum, Thomas Industries, Inc. under this warranty is limited to servicing, adjusting, repairing, or replacing any unit or component part which in the judgment of Welch Vacuum, Thomas Industries, Inc. has not been misused, abused, or altered in any way or damaged by ingestion of foreign material causing impaired performance or rendering it inoperative. No other warranties are expressed or implied. The method of executing this warranty: servicing, adjusting, repairing, or replacing, shall be at the discretion of Welch Vacuum, Thomas Industries, Inc. Vacuum pumps that have been operated within a vacuum system, or other system, for any period, however short, will be repaired under this warranty rather than replaced.

The warranty is effective for one year from the date of original purchase when:

1. The warranty card has been completed and returned.
2. The product is returned to the factory or other designated service centers, freight prepaid.
3. The product in our judgment is defective through no action or fault of the user.

If the product has become defective through misuse, abuse, alteration, or ingestion of foreign material, repairs will be billed regardless of the age of the product. In this event, an estimate of the repair costs will be submitted and authorization of these charges will be required before the product is repaired and returned.

Vacuum Pump Repair Facility

7301 N. Central Ave.
Skokie, IL 60077
Phone: (847) 676-8800 Ext. 1
Fax: (847) 677-8806

OWNER'S MANUAL
For
DRY VACUUM PUMPS
MODELS 2562 & 2567
Part No. 67-1356

Copyright 1998-2002 Welch Vacuum, Thomas Industries, Inc.
Welch is a registered trademarks of Welch Vacuum, Thomas Industries, Inc.

642518