

TPS MOUNTING INSTRUCTIONS FOR: XRS, XRS YOUTH, S, S YOUTH, R, CPX-R, CPV-R, CS-R, CS

STEP 1

Drill the center front hole through the middle "C" in the word casCade or $3/8"$ up from bottom of chin piece using a $7/32"$ drill bit.

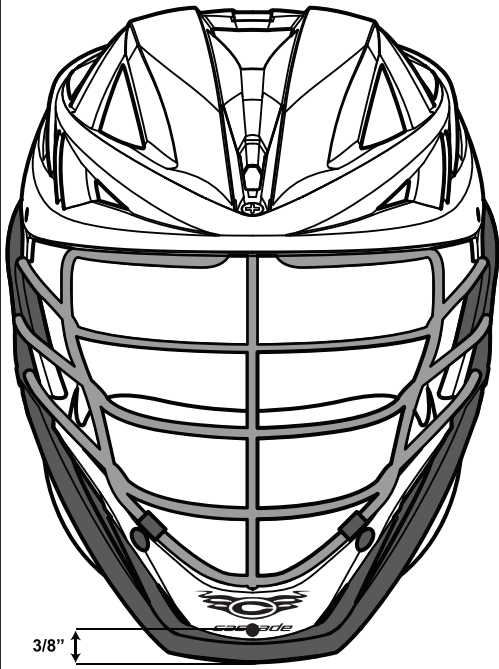

STEP 2

Drilling each side hole location depends on your helmet, choose your helmet below. You will need to measure from the center of the side hook-up screw to the specified location.

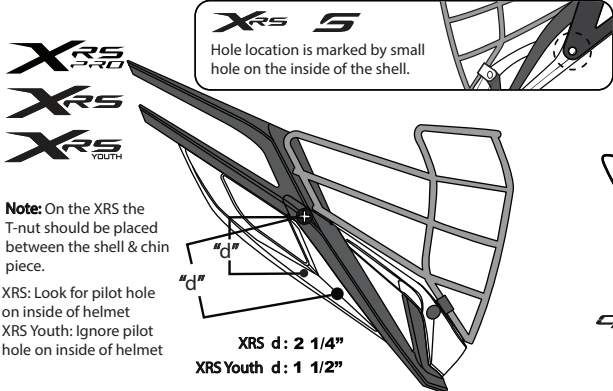

Note: On the XRS the T-nut should be placed between the shell & chin piece.

XRS: Look for pilot hole on inside of helmet
XRS Youth: Ignore pilot hole on inside of helmet

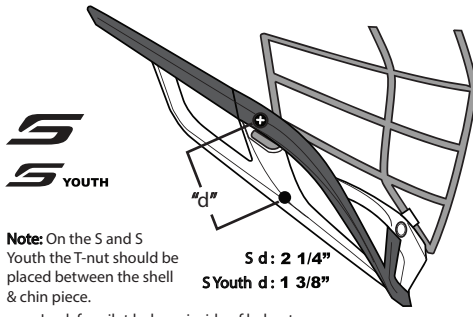

Note: On the S and S Youth the T-nut should be placed between the shell & chin piece.
Look for pilot hole on inside of helmet

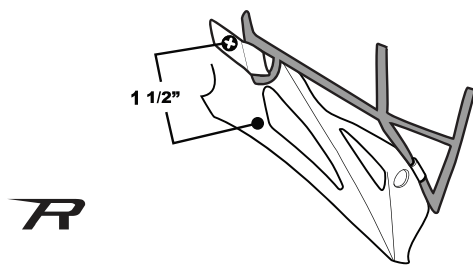

Parts

- 1 TPS throat piece,
- 1 short, 2 long l-nuts,
- 2 silver screws, 2 silver bushings,
- 1 black screw, 2 black bushings.

Tools Needed

- Drill, $7/32"$ drill bit, ruler,
- Phillips head screwdriver, marker.

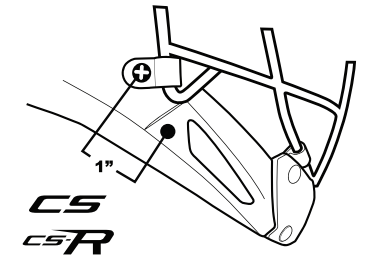
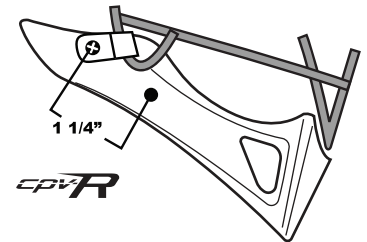
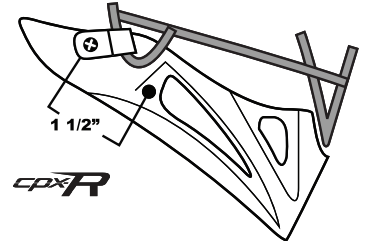

STEP 3

Center Front: Follow the illustration to hook up webbing to your chin piece.

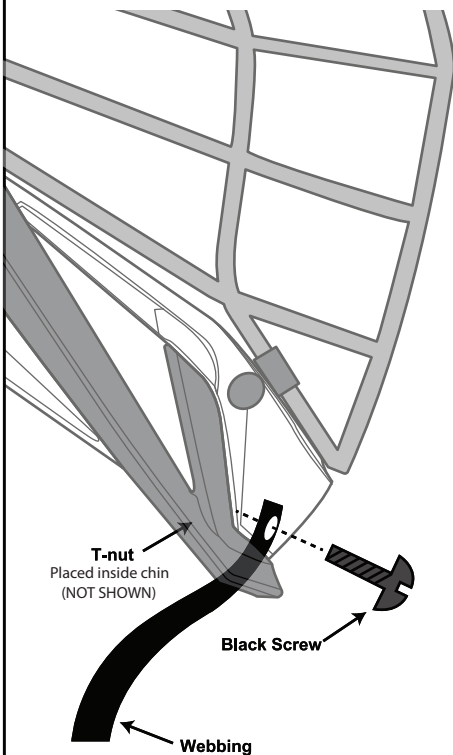

STEP 4

Side: Follow illustration to hook up the left side. Then mirror for the right. Screw head must be flush to silver spacer.

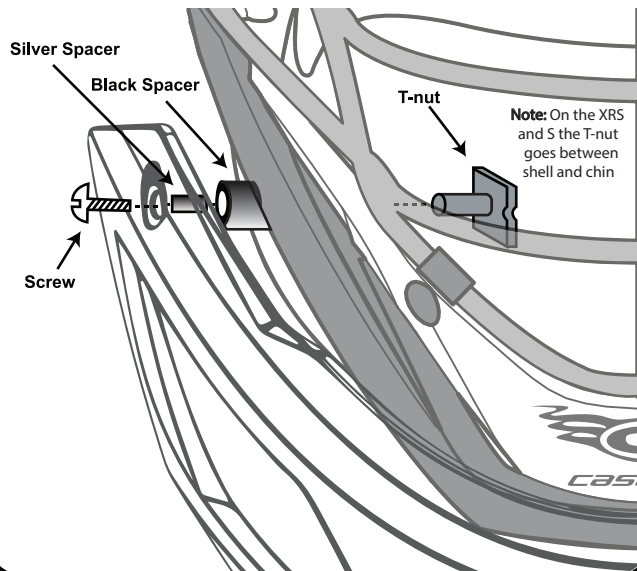

All pieces must be installed for the TPS to work properly.

Make sure the TPS moves freely up and down.

Check that all 3 screws are firmly tightened.

DO NOT USE IF THE TPS DOES NOT FREELY MOVE OR IS CRACKED

Please call us @ **1.800.537.1702** if you need assistance.

WARNING

No equipment can prevent all injuries. Lacrosse is a body contact sport. The ball moves at high speed. People get hurt and killed playing the game of lacrosse. This TPS throat piece cannot prevent all injuries to the neck, face, eyes, teeth, brain, skull and body. Some steps to reduce your risk of injury are to: follow the rules of the game, be smart, and carefully inspect all of your equipment prior to each time you go onto the field. Do not use equipment that is bent, broken, or defective.

Cascade
PASSION TO PROTECT
4697 Crossroads Park Drive
Liverpool, NY 13088
800.537.1702 [toll free]
315.453.3073 [outside USA]
315.453.3762 [fax]

ASSEMBLED AND PLAYED
IN THE USA



TPS MOUNTING INSTRUCTIONS

XRS PRO, XRS, XRS YOUTH, S, S YOUTH, R, CPX-R, CPV-R,