

BADU[®]JET Inspiration

SwimJet System

SPECK X

Features

- Two-piece body molded of a heavy duty ABS plastic immune to chemicals and environmental abuse, to provide a rugged and attractively styled water treadmill.
- Adjustable recessed jet nozzles.
- Light (ON/OFF) button turns low voltage light ON/OFF.
- Pump (ON/OFF) pneumatic button guarantees complete separation between pool water and pump motor control.
- Air regulator (OPEN/CLOSE) knob permits a controlled mixture of air into the water flow and creates a unique, invigorating, bubble effect. It will also add additional resistance to swim against.
- Includes approximately 14 ft. GFCI twist-lock cord.
- Speck 4.0 HP self-priming plastic pump. Single phase with thermal overload (*no motor start required*). (*Not Shown*)
- The system comes with 5 ft. pulsating massage hose that can be attached to jet nozzle.
- **NEW for 2018:** System will include the nozzle adjustment tools to help set the jet nozzles in position for optimum performance
- Packed in one carton on a pallet and shipped via truck line. Shipping weight is 115 lbs.

Installation

The Badujet can be mounted over the wall of most pools with little installation, effort or cost.

This self-contained unit comes complete with pump, control box, electrical cord with GFCI and mounting hardware. The Badujet Inspiration requires no additional equipment for installation. Just supply pool, water and electricity. Pump and control are also available in 3 phase. Read all instructions before installing.

Consult your physician before attempting any strenuous exercise. This product may not be challenging or satisfying for all levels of exercise.

Dimensional Drawing

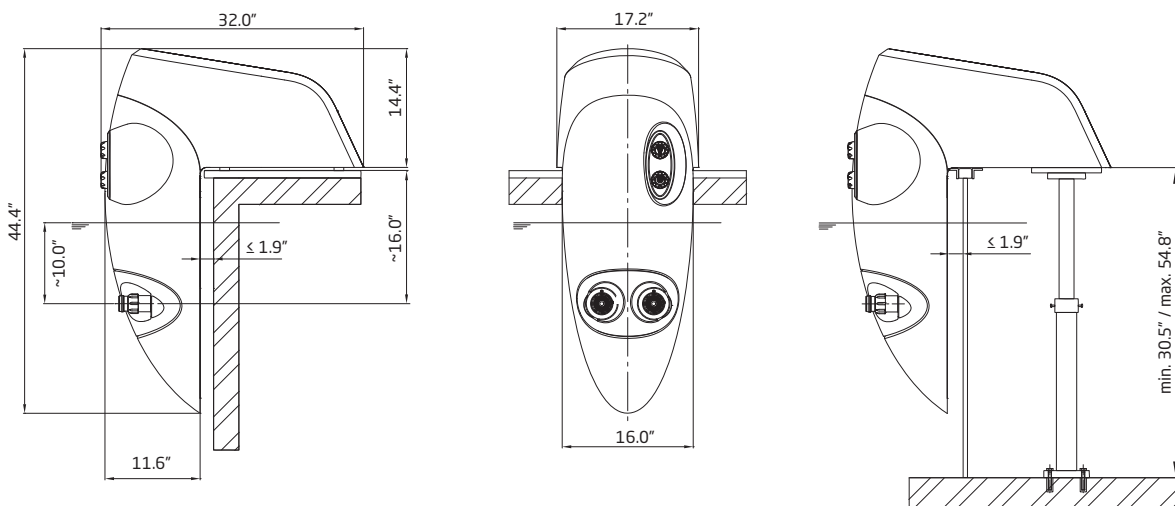

Trademarks and Certifications



Complies with UL 1563
CSA C22.2 No. 218.1-M89
Swimming Pool Equipment
Listing #E212148



VGB 2008

Applications

- Perfect for in-ground & above-ground pools (Commercial & Residential)