

New Equipment Warranty

Limited Warranty

Sandia Products warrants new equipment against defects in material and workmanship under normal use and service to the original purchaser. Any statutory implied warranties, including any warranty of merchantability or fitness for a particular purpose, are expressly limited to the duration of this written warranty. Sandia Products will not be liable for any other damages, including but not limited to indirect or special consequential damages arising out of or in connection with the furnishing, performance, use or inability to use the machine. This remedy shall be the exclusive remedy of the purchaser. The warranty period is subject to the conditions stated below.

Lifetime Warranty on Body, 2-Years on Vacuum Motors, 1-Year on Pump and all Electrical Parts, 90-Days on Tools and Accessories

Sandia Products warrants the roto-molded body to be free from defects in material and workmanship, under normal use and service for a lifetime. Sandia Products warrants the motors to be free from defects in material and workmanship, under normal use and service for two (2) years from the original date of sale and the pump/electrical parts one (1) year. Parts replaced or repaired under this warranty are warranted for the remainder of the original warranty period. Service labor charges are covered for one (1) year from the date of purchase, when performed by a manufacturer-authorized service provider.

Labor is only provided by authorized service centers. If an authorized service center is not near you, it is the purchaser's responsibility to take their machine to an authorized service center.

Normal wear items such as capacitors, cords, finishes or switches will be warranted for manufacturing defects for ninety (90) days from the purchase date.

All warranties of motors and associated components will be voided: if the machine is serviced by anyone other than an authorized service provider; if the machine is mechanically modified; if the machine is operated when not operating properly; or if the machine is misused or abused.

The warranty starts on the purchase date by the original purchaser from Sandia Products subject to proof of purchase. The Machine Registration Card must be completed and returned immediately at the time of purchase. Registration may also be performed online at: www.sandioplastics.com/registration.aspx. If proof of purchase cannot be identified, the warranty start date is ninety (90) days after the inventory stocking date at the distributor's warehouse.



Ultimate Solutions Corporate Office
15571 Container Lane, Huntington Beach, CA 92649
Phone: 800-983-5834 | Fax: 714-901-8404
www.us-group.com | www.sandioplastics.com

Make a copy of this card for future reference.

Copyright © 2016 Ultimate Solutions | Sandia Products. All Rights Reserved.

SAFETY, OPERATION AND MAINTENANCE MANUAL WITH PARTS LIST

Please read before use!

1200 PSI ADJUSTABLE PUMP, DUAL MOTORS



ACTIVATE
YOUR
WARRANTY!

Model No. 80-5000



IMPORTANT INFORMATION AND SAFETY INSTRUCTIONS

Register your Machine Online or Return your Machine Warranty Card!

Serial No: _____

HARD SURFACE EXTRACTOR
Sniper 12-Gallon 1200 PSI Hard Surface Extractor



Manufactured with
Pride in the U.S.A.

Another Innovative
Product from
Sandia
PRODUCTS
Your Ultimate Choice in
Profitable Cleaning Performance!



ULTIMATE
SOLUTIONS

Together We're Better!

Dear Valued Client,

Congratulations on the purchase of your Sniper 12-Gallon 1200 PSI Hard Surface Extractor! The world of floor cleaning is becoming more high-tech and competitive and we strive to provide you with the most innovative products. Our extractor is yet another example of this, bringing a new dimension to high-pressure floor cleaning with its cutting-edge features, quality and value.

Please review this manual paying careful attention to the Safety Instructions section. Keep in mind that any unnecessary damage, neglect or abuse of this machine will void your warranty. You can be confident that simple maintenance will ensure that your extractor provides quality performance for many years to come.

If warranty questions arise, please consult your manual or contact your distributor. Should you have any questions regarding maintenance, replacing parts or ordering parts, please call an authorized distributor.

Before you begin using your extractor thoroughly review the Owner's Manual.

Again, congratulations on the purchase of your Sniper 12-Gallon 1200 PSI Hard Surface Extractor!

Equipment Videos

Machine Training: www.sandiaplastics.com/equipmentVideos.aspx

Machine Features and Benefits: www.sandiaplastics.com/featuresVideos.aspx

Questions or Comments?

Phone: 714-901-8400

Toll Free: 800-983-5834

Fax: 714-901-8404

Ultimate Solutions Corporate Offices:

15571 Container Lane, Huntington Beach, CA 92649

Visit our website at: www.sandiaplastics.com

Register your machine online at: www.sandiaplastics.com/registration.aspx



ACTIVATE YOUR WARRANTY!

Please take a moment to register your machine. Fill out the information below and mail back to Sandia Products immediately.

The warranty starts on the purchase date by the original purchaser subject to proof of purchase. This Machine Registration Card must be completed and returned immediately at the time of purchase. If proof of purchase cannot be identified, the warranty start date is ninety (90) days after the inventory stocking date at the distributor's warehouse.

Your machine may also be registered online at:

www.sandiaplastics.com/registration.aspx

Machine Model _____ **Purchase Date** _____

Motor Type _____ **Serial No.** _____

Place of Purchase _____

Shipped To _____

Your Name _____ **Phone** _____

E-mail _____ **Fax** _____

Address Line 1 _____

Address Line 2 _____

City _____ **State** _____ **Zip** _____

Comments:

Mail to:

Ultimate Solutions Corporate Offices
15571 Container Lane
Huntington Beach, CA 92649

**See reverse side for Warranty Information.
Make a copy of this card for future reference.**

Copyright © 2016 Ultimate Solutions | Sandia Products. All Rights Reserved.

12-GALLON HARD SURFACE EXTRACTOR

By Ultimate Solutions | Sandia Products

Please fill out the following information:

Model No: _____

Serial No: _____

Distributor Name: _____

Distributor Phone No: _____

Date of Purchase: _____



The Ultimate Solutions Group
Our Family of Companies
TOGETHER WE'RE BETTER!

Sandia
PRODUCTS

Your Ultimate Choice in
Profitable Cleaning Performance!

Ultimate Carpet Solutions
www.sandioplastics.com



Ultimate Hard Floor Solutions
www.mercuryfloormachines.com



Ultimate Cleaning Solutions
www.ultimatesolutionsinc.net



Operating Manual Table of Contents

Warranty Policy	4
RMA Procedure.....	5
1.0 Safety Instructions	5
2.0 Grounding Instructions	7
3.0 Care of your Machine	7
4.0 Prepare Unit for Use	8
4.1 Automatic Chemical Feed	8
4.2 Pressure Pump System	10
4.3 Vacuum System	10
5.0 Set-Up and Operation	11
5.1 Electrical Cords	11
5.2 Water and Chemical Dilution - Auto Fill	11
5.3 Connection of Solution Hose	13
5.4 Power Priming the High Pressure Pump	14
5.5 Connection of Vacuum Hoses	14
5.6 Connection of Auto-Dump Hose	15
5.7 Adjusting the Pressure.....	16
5.8 Switch Panel.....	17
6.0 Shutdown Procedures	18
7.0 Maintenance	19
7.1 Clean Chemical Feed Filter	19
7.2 Clean Chemical Feed Foot Valve	19
7.3 Clean Fresh Water Tank Filter	19
7.4 Clean Vacuum Shut-Off Float Assembly Screen	20
7.5 Clean Clear View In-Line Filter.....	20
7.6 Clean Auto-Dump Pump-Out	21
7.7 Rinse Out Recovery Tank	21
7.8 Flush Solution Tank and Pump	21
7.9 Clean Waste Pump	23
7.10 Clean Pump Inlet Filter	23
7.11 Clean In-Line Pump Filter	24
7.12 Flush Chemical System.....	24
7.13 WD-40 Vacuum Motors	25
8.0 Trouble Shooting Guide.....	26
9.0 Solution Tank Schematic Drawing and Parts List	28
10.0 Recovery Tank Schematic Drawing and Parts List	30
11.0 Base with Vac Components Schematic Drawing and Parts List.....	32
12.0 Base Pump Components Schematic Drawing and Parts List	34
13.0 Wiring Diagram	36
14.0 Storage and Freeze Protection	37

New Equipment Warranty

Lifetime on body, 2-years on vacuum motors, 1-year on pump and all electrical components, 90-days on tools and accessories.

Warranty Policy

All equipment is inspected and tested before shipping from the manufacturer. All parts are warranted to be new and free from defects in workmanship and material, under normal use to the original retail purchaser. This warranty limits manufacturer's liability for defects in workmanship or materials for replacement of defective parts only. The manufacturer accepts no liability for incidental or consequential damages arisen from the use of any equipment, defective or not. This warranty is in lieu of all expressed or implied warranties and is extended only to the original retail purchaser. Manufacturer sales and service representatives are not authorized to waive or alter the terms of this warranty, or to increase the obligations of the manufacturer under the warranty. Parts replaced or repaired under this warranty are warranted for the remainder of the original warranty period.

Labor is only provided by authorized service centers. If an authorized service center is not near you, it is the purchaser's responsibility to take their machine to an authorized service center.

The manufacturer covers up to one (1) year (365 days) of service labor at the manufacturer's calculated hourly labor rate/repair time when performed by a manufacturer-authorized service provider. Ultimately, labor reimbursement costs are at the discretion of the manufacturer. At no time is the manufacturer responsible for travel time to complete on-call repairs. After one (1) year, the original retail purchaser is responsible for all labor costs with no manufacturer reimbursement.

The original purchaser must contact the manufacturer to follow correct RMA/warranty procedures. They must include a copy of the RMA Sheet enclosed in the box with the returned item. No returns shall be authorized unless the proper RMA procedures are followed. It is the responsibility of the distributor to repair the client's equipment as soon as possible.

The manufacturer charges a 25% restocking fee for any items that are being returned to stock. Items must be new, unused, free of damage and are only good for up to 30 days. After 30 days, the manufacturer does not accept the return of any items for a store credit.

Authorized warranty replacement parts need to come directly from the manufacturer. Any use of any other parts will void warranty. The manufacturer does not reimburse for parts used by client that were not supplied directly for the machine under warranty.

The client must contact the manufacturer prior to working on or changing out of any parts, etc. The manufacturer must issue an RMA Sheet containing approved labor time and replacement parts. Do not send parts or equipment back to the manufacturer without an RMA Number and approval. No labor will be paid for, nor parts cost paid for or reimbursed, that have not previously been approved by the manufacturer. All warranty work must be approved and authorized to qualify, and appropriate warranty procedures must be followed.

The warranty starts on the purchase date by the original purchaser from an authorized distributor, subject to proof of purchase. The Machine Registration Form must be completed and sent to the original manufacturer at the time of purchase. If proof of purchase cannot be identified, the warranty start date is ninety (90) days after the date of sale to an authorized distributor.

Register your machine online at: www.sandiplastics.com/registration.aspx.

14.0 Storage and Freeze Protection

You must winterize your Hard Surface Extractor to protect the pump system from freezing and also damage being caused to fittings and valves. Damage due to freezing is not covered under the Warranty. Store your extractor in temperatures over 40 degrees Fahrenheit. If you plan on storing your extractor in freezing conditions or for a long period of time, the following procedure should help prevent your Hard Surface Extractor from freezing and prevent pump and seals from drying out.

Recommended Procedure for Storage

- Pour a quart of RV Water System Antifreeze into the solution tank.
- Connect the pressure hose to the female quick disconnect (QD) on the front of the machine. Insert an open-ended male QD into the female QD on the end of the pressure hose.
- When primed, turn down the pressure to 100 PSI.
- Disconnect the open-ended QD and connect the solution hose to the male QD at the auto-fill/chemical feed connection. CAUTION: applying high pressure (over 100 PSI) to the chemical feed system will damage the mechanism.
- With the chemical feed supply tube at the bottom of the solution tank, turn on the pump and allow to circulate for 10 minutes. Check to make sure the chemical supply tube is drawing the antifreeze solution. This will introduce antifreeze into the chemical feed system.
- Disconnect the solution hose from the chemical feed and allow the system to bypass for 10 minutes. This will work antifreeze into the pressure gauge.
- Attach and wands and hand tools that will also be stored with the Hard Surface Extractor. Open the valve for 30 seconds, directing the spray to the solution tank. Disconnect the hose and with the valve open and the jets pointing down, depress the dimple on the male QD. This will drain the solution out of the tool. Drain thoroughly before storing.
- Turn off the pump and disconnect all hoses and tools. Vacuum out the solution tank and thoroughly drain the recovery tank and vacuum hose.

The auto-dump pump-out does not require freeze protection as long as the recovery tank is completely drained and allowed to thoroughly dry. To return to service, flush the pressure system by repeating the above steps, using fresh water in place of antifreeze.

13.0 Wiring Diagram

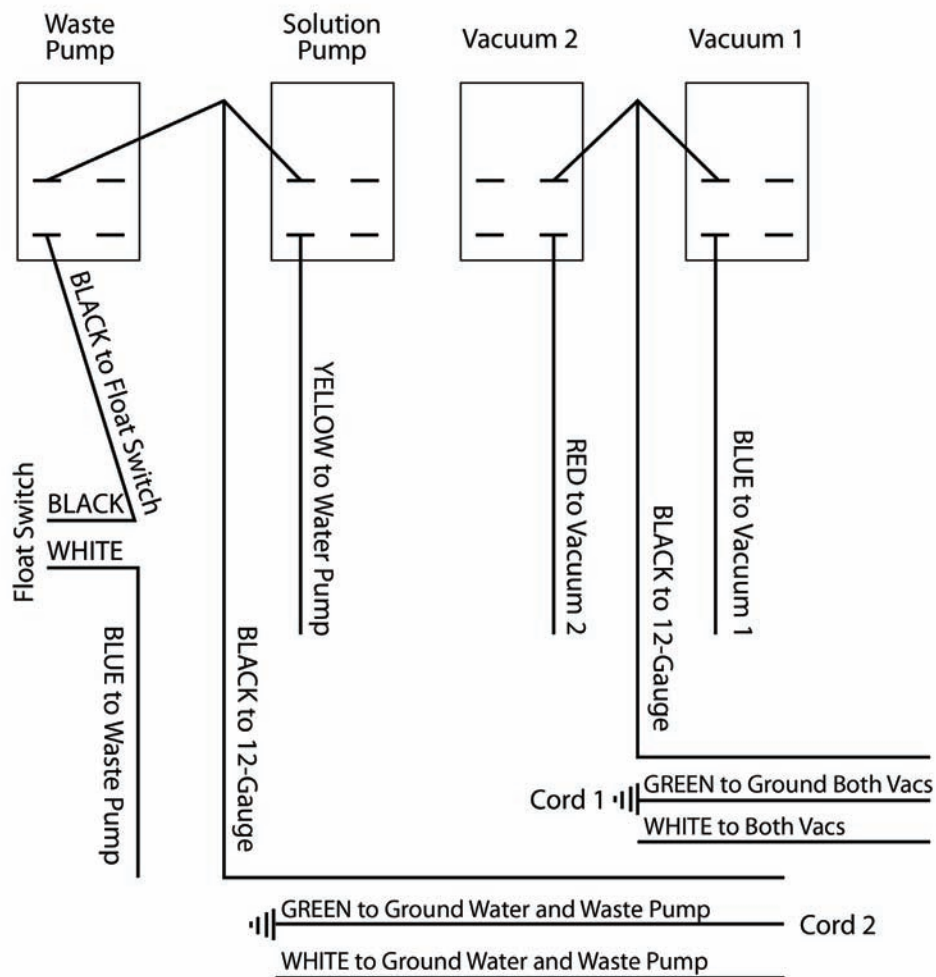

Returned Material Authorization (RMA) Procedure

Original purchaser (distributor/service center) must contact the manufacturer to follow correct RMA/warranty procedures. Must include a copy of RMA Sheet enclosed in the box with returned item. No returns shall be authorized unless proper RMA procedures are followed. It is the responsibility of the distributor to repair the client's equipment as soon as possible. Labor is only provided by authorized service centers. If an authorized service center is not near you, it is the purchaser's responsibility to take their machine to an authorized service center.

Client must contact the distributor prior to working on or changing out any parts, etc. Manufacturer must issue an RMA Sheet containing approved labor time and replacement parts. Do not send parts or equipment back to manufacturer without an RMA number and approval. No labor will be paid for, nor part costs paid for or reimbursed that have not been previously approved by the manufacturer. All warranty work must be approved and authorized to qualify and appropriate warranty procedures must be followed.

1.0 Safety Instructions

READ THIS MANUAL BEFORE OPERATING MACHINERY. KNOW THE PROPER SET-UP, OPERATION, CORRECT APPLICATIONS AND THE LIMITATIONS OF THIS EQUIPMENT BEFORE USE.

This machine will afford you many years of trouble-free operating excellence, provided it is given the proper care. All parts have passed rigid quality control standards throughout the assembly process. Prior to packaging, your equipment was again inspected for assurance of flawless operation.

This machine is protectively packed to prevent damage in shipment. We recommend that upon delivery, unpack the unit and inspect it for any possible damage. Only a visual inspection will reveal damage that may have occurred.

If damage is discovered, immediately notify the transportation company that delivered your equipment. As a shipper, we are unable to report any claim for damage. You must originate any claim within five (5) days.

This manual is for your protection and information. Please read carefully since failure to follow precautions could result in discomfort or injury.

Reduce the Risk of Fire, Electric Shock or Injury

Use only as described in this safety operating manual. Use only the manufacturer's recommended attachments, accessories, replacement parts and filters. Replace damaged or worn parts immediately with genuine, original equipment parts to maintain safety and to protect your limited warranty.

Always turn OFF the machine before connecting, disconnecting or working on the equipment. This machine must be connected to a properly grounded outlet only (see grounding instructions). The extension cords provided with this unit are two 25-foot, 12/3-gauge wires and MUST be used with this unit to ensure grounding protection. The two (2) power cords must be plugged into separate circuits during operation. Power Cord 1 (left side) must be on a 20 Amp circuit to use both vacuums. Power Cord 2 (right side) must be on a 15 Amp circuit if the Auto Pump-Out is not used or a 20 Amp circuit if it is used.

1.0 Safety Instructions Continued

Turn off all controls before unplugging. This is not a toy. Close attention is necessary when used around or near children. Use common sense to protect yourself and others from injury when using the machine and always wear the appropriate clothing and safety equipment when operating the unit.

- DO NOT leave the machine when plugged in. Unplug it from the outlet when not in use and before servicing.
- DO NOT use this equipment with a damaged cord or plug. If the unit is not working as it should because it has been dropped, damaged, left outdoors, etc., contact an authorized service center.
- DO NOT unplug the equipment by pulling the cord. To unplug, grasp the plug, not the cord. DO NOT pull the unit by the cord, use the cord as a handle, close a door on the cord, or pull the cord around sharp edges or corners. Keep the cord away from heated surfaces. Lift using only the appropriate handles.
- DO NOT overstretch the safety power cord between the equipment and the electrical outlet in the wall.
- DO NOT move the machine up or down stairs with fluid in the machine. Drain solution and recovery tanks before moving the unit up or down stairs. Use extra care when cleaning on stairs.
- DO NOT handle the plug of the equipment with wet hands.
- DO NOT expose to rain or use on wet surfaces, to avoid electric shock. Store indoors.
- DO NOT leave machine outdoors, in extreme heat or cold. Harsh weather elements will damage components and void warranty.
- DO NOT pick up anything that is burning or smoking such as cigarettes, matches or hot ashes.
- DO NOT use the equipment to pick up flammable or combustible liquids such as gasoline or use in areas where they may be present.
- DO NOT use where oxygen or anesthetics are used.
- DO NOT put objects into openings or use with any openings blocked. Keep free of dust, lint, hair and anything that may reduce air flow. Keep hair, loose clothing, fingers, and all body parts away from openings and moving parts to ensure safe operation.
- DO NOT use if any hoses or nozzles are damaged, cut or punctured.
- DO NOT allow pump to run dry. Always maintain an adequate solution level to supply solution pump.
- DO NOT use Citrus Acid, Buterol or harsh degreasers inside the machine.
- DO NOT lubricate the motor. If the motor is lubricated, this will VOID your warranty.

12.0 Base with Pump Components Parts List

Drawing No.	Item No.	Description	Quantity
58	10-0832	S/R Strap Bolts	1
59	10-0834	Pump Flat Washer	16
60	10-0831	S/R Bracket for Extractor	1
61	80-0112-UN	12-- PSI Unloader Valve / Regulator	1
62	80-0059-4	1200 PSI Extractor Gauge	1
63	10-0838	Pigtail for Extractor	2
64	10-0850	Strain Relief for Extractor Pigtail	2
65	10-0851	Strain Relief Nut for Extractor Pigtail	2
66	10-0822	Exhaust Grate	1
67	10-0835-N	Nut for Pump Bolt on Extractor	4
68	10-0835-B	Pump Bolt	4
69	10-0834	Flat Washer	4
70	80-0112	1200 PSI Pump Kit (Includes Hoses)	1
71	10-0826	3/4" Hose Clamp	2

4.0 Prepare Unit for Use

DO NOT USE ON WET SURFACES. DO NOT EXPOSE TO RAIN. STORE INDOORS.

- All hard surface extractors, no matter what the time of year, are shipped with antifreeze in the solution lines. Prior to first use, fill the solution tank with one quart of warm water. Attach the hose and using a hand tool or wand, flush out the system by spraying the one quart of water through the pump.
- Attach the vacuum hose and the brass quick disconnect.
- Fill the solution tank with warm water (less than 100 degrees Fahrenheit). Fill to approximately 4 inches from the top. Pre-spray and agitate the surface with detergent made for floor cleaning or upholstery. Use only warm water to extract the pre-spray from the surface.
- Be sure to replace any filters back into the machine prior to use.
- Do not use citric acid, butyl glycol or harsh degreasers inside the machine.

4.1 Automatic Chemical Feed

WARNING: THE HARD SURFACE EXTRACTOR IS DESIGNED FOR US WITH WATER-BASED CLEANING SOLUTIONS, SUCH AS LOW-FOAMING DETERGENTS OR ACID RINSES. Never use dry solvent solutions. The use of dry solvents in your extractor will void the warranty.

Chemical Metering: the Hard Surface Extractor is equipped with an automatic water fill/chemical feed metering system. As the solution tank fills with water, cleaning concentrate is drawn into the solution tank at a designated rate, via metering tip. A complete set of metering tips are included.

Metering Tip Replacement: to adjust the amount of cleaning concentrate being drawn, simply remove the plastic supply tube from the chemical feed metering valve (Figure 1). Continues on the next page.

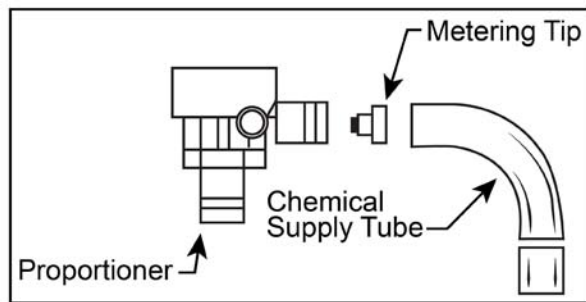
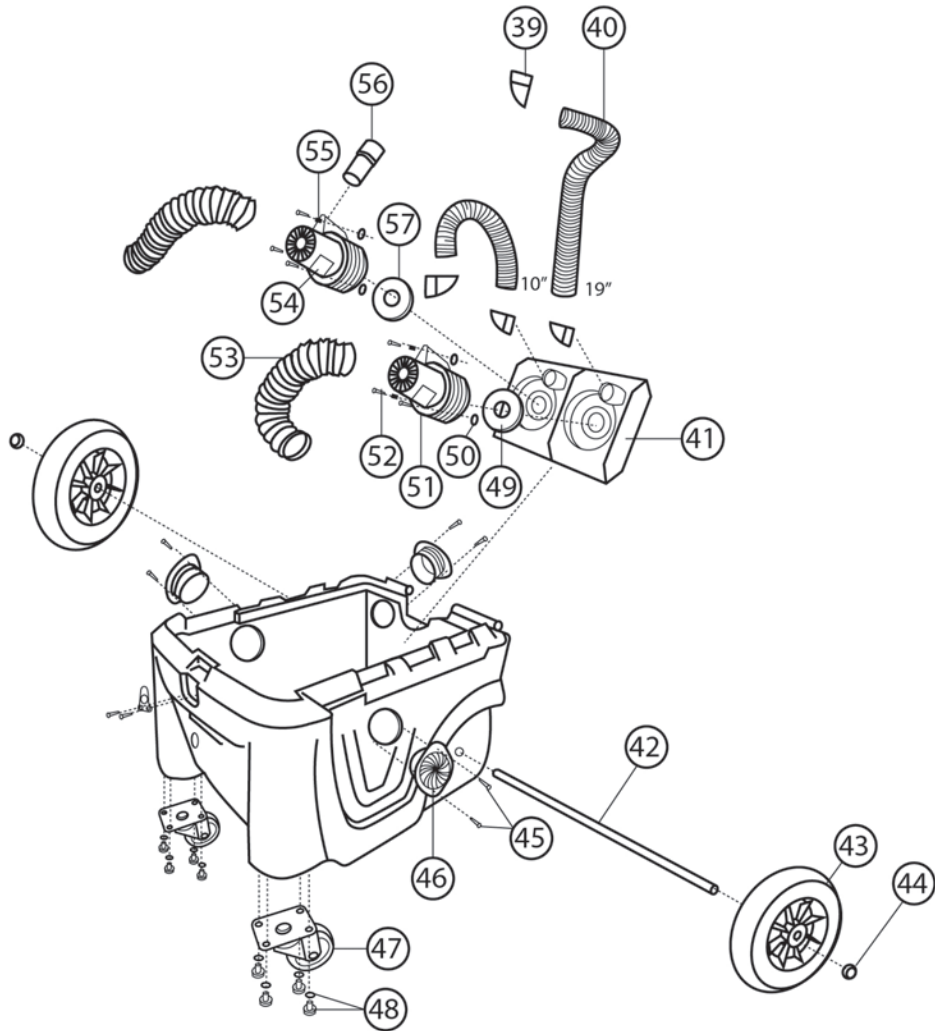

Figure 1: Metering Tip Replacement

11.0 Base with Vacuum Components Parts List

Drawing No.	Item No.	Description	Quantity
39	10-0848-B	1-1/2" 90 Degree ABS Street Elbow	4
40	80-0003-A	1-1/2" Black Lined Gray Hose	2
41	SN-12-MFLD	Extractor Motor Manifold	2
42	10-0836	19" Axle for Extractor	1
43	10-0807	Wheel for Extractor	2
44	10-0820	End Cap for Extractor Axel	2
45	10-0419-A	Screw for Extractor Hatch	6
46	10-0822	Exhaust Grate	3
47	10-0808	Caster for Extractor	2
48	10-0816	1/4-20 - 1/2" Hex Caster Bolt	8
49	10-1030-S2	2-Stage Extractor Motor Gasket	1
50	10-0204	Motor Mount Back-Up Washer	6
51	10-0811	2-Stage Extractor Motor	1
52	10-0833-L	Manifold Bolt 10-32 x 1/4" Hex Screw	6
53	T-A001	Cooling Duct	2
54	10-0810	3-Stage Extractor Motor	1
55	80-0116	Spacer for Extractor Motors	6
56	10-0155	Straight Hose Cuff	1
57	10-1030-S3	3-Stage Extractor Motor Gasket	1

11.0 Base with Vacuum Components Schematic Drawing



4.0 Prepare Unit for Use Continued

4.1 Automatic Chemical Feed Continued

Metering Tip Replacement CONTINUED: Unscrew the colored metering tip and replace with the tip that corresponds to the portable dilution ratio for your cleaning product (Figure 2). Reconnect the plastic supply tube.

Liquid Concentrates: the Hard Surface Extractor comes with the orange metering tip installed at the factory. This tip is rated for a 0.4 oz. of chemical per gallon of water, which is a standard dilution ratio for the most popular liquid cleaning products on the market. Refer to your product's dilution ratio for portable extractors and select the proper metering tip from the chart displayed in Figure 2.

Fresh Water Rinse: for fresh water rinsing, simply leave the chemical supply tube in the solution tank.

Manual Filling: to use the Hard Surface Extractor without the automatic filling system, simply pre-mix your solution.

Figure 2: Metering Tip Dilution Ratios

Tip Color	Concentrated Dilution Ratio (oz./gal.)	
	Liquids	Powders
Tan	0.30	---
Orange	0.40	---
Turquoise	0.50	---
Pink	0.75	---
Clear	1.00	---
Brown	1.12	---
Red	1.50	---
White	1.75	---
Green	2.00	0.25
Blue	2.50	0.30
Yellow	3.75	0.47
Black	5.00	0.63
Purple	8.50	1.06
Gray	11.50	---
None	16.25	---

Setup: inside the solution tank is a bottle float. Check the chemical feed supply foot valve for debris and clean if necessary. Insert the line into the cleaning concentrate so that it touches the bottom of the bottle. Set cleaning concentrate on the machine or inside the fresh water solution tank opening.

Connect the fill hose to the quick disconnect located on the back of the machine. Attached the water supply hose to any available faucet. It may require adapters to fit the various faucet combinations you will encounter. Never force a threaded fitting. Place a towel over the faucet connection so that any spray will be controlled. Turn on the water and check the hose connections for leaks.

The solution tank will fill approximately half full (about 5-gallons). As the tank is filling, cleaning concentrate is being drawn into the solution tank.

Shutdown: before the end of each job, turn off the water supply to prevent the solution tank from becoming completely full. With the cleaning completed and the solution pump turned off, disconnect the fill hose from the faucet, drain the water in the fill hose back into the solution tank and remove the fill hose. Remove the chemical feed supply tube from the chemical solution jug, clean the filter and place into the solution tank. Vacuum out the solution tank and clean the solution tank water filter.

4.0 Prepare Unit for Use Continued

4.2 Pressure Pump System

The Hard Surface Extractor utilizes a twin piston pump which is adjustable from 100-1200 PSI. Never operate the pump at a pressure setting over 1200 PSI or without water in the solution tank. Doing so will damage the pump and will void the warranty. Anytime the Hard Surface Extractor has been stored for a period of time or has had the pump run “dry,” the solution pump will have to be primed to remove air which might be trapped in the pumping system (see “Priming the Solution Pump” section).

When high pressure drop is engaged, a pressure drop of approximately 100 PSI is considered normal. However, if pressure drops greatly exceeding 100 PSI or if there is strong pulsation in the solution hose, prime the pump.

Pressure Regulator (Unloader Valve): pressure is easily adjusted by a pressure regulator located on the rear of the machine next to the pressure gauge, only when the valve to a wand or high pressure valve is engaged. To increase the solution pressure, twist the regulator handle clockwise. DO NOT operate the pump above 1200 PSI.

Priming the Solution Pump: connect the pressure hose to the female quick disconnect (QD) on the front of the machine. Insert an open-ended male QD into the female QD on the end of the pressure hose.

Turn on the pressure pump switch and the vacuum switches (both vacuum I and II switches). Direct the solution back into the recovery tank through the vacuum inlet. Cup your hand around the vacuum inlet allowing the vacuum from the Hard Surface Extractor to pull the solution through the solution hose. Allow solution to run for 10 seconds. This allows the solution to push out any air in the pumping system. Repeat this procedure if necessary. When the pressure hose is connected to the wand, the pressure drop should only be approximately 100 PSI.

4.3 Vacuum System

Vacuum Motors: the Hard Surface Extractor utilizes a unique two (2) vacuum system, using one (1) 3-stage and one (1) 2-stage motor, which produces both outstanding vacuum lift and airflow for superior extraction and drying times. The vacuum system can be used with one vacuum motor for cleaning delicate fabrics or both vacuum motors for carpet cleaning, water extraction and hard surface cleaning.

Automatic Vacuum Shut-Off: The float assembly shut-off, located in the recovery tank on the vacuum stand pipe, prevents the waste tank from overflowing into the stand pipe and damaging the vacuum motors. The float assembly will cut-off vacuum to the waste tank. When this happens, immediately turn off the vacuum motors and empty the waste tank. If the operator continues to use machine after the tank is full, it will void the Warranty. The float assembly has a filter to prevent lint and debris from entering the stand pipe. Refer to the “Maintenance” section for removal and proper cleaning.

Recovery Tank: the vacuum system requires the use of an external filter. The clear view in-line filter is included with the machine and must be used on every job.

It is also necessary to use a defoamer to eliminate foam build-up in the recovery tank which could lead to foam/moisture entering the vacuums and contributing to early failure of the vacuum motors. If moisture does enter the vacuum motors, contact an authorized service center. To prevent moisture from damaging the vacuum motors during storage, empty the recovery tank and store with the lid open.

10.0 Recovery Tank Parts List

Drawing No.	Item No.	Description	Quantity
12	10-0419-A	Screw for Extractor Hatch	6
13	10-0804	Hatch Cover	1
14	10-0804-A	Hatch Cover Gasket	1
15	80-0101	3/4" Check Valve	1
16	80-0100	3/4" Hose x 3/4" MNPT	1
17	80-0100	3/4" GHT Cap	1
18	10-0820	End Cap for Hinge	2
19	10-0821	Extractor Hinge	2
20	10-0830	Hinge Keeper	2
21	10-0805	Dump Valve	1
22	80-0011-2	90 Degree Street Elbow	2
23	80-0004	1/4" x 4" Brass Nipple	1
24	80-0032	3/8" Bulk Head Fitting	1
25	80-0115-B	3/8" MPT x 1/2" Brass Barb	1
26	10-0849	1-1/2" ABS Fitting	1
27	80-0008	1.5 PVC Femal Adapter	1
28	10-0416-A	1-1/2" Black ABS Stand Pipe	1
29	80-0012	Shut-Off Assembly for Extractor	1
30	80-0105	Float Switch for Sump Pump	1
31	80-0103	Sump Pump	1
32	80-0108	3/4" Bard x 3/4" SFGHT	1
33	80-0113	1" Hose Clamp	2
34	80-0106	3/4" Hose for Auto-Dump	1
35	80-0102	3/4" MNPT x 3/4" Barb	1
36	10-0806	1-1/2" Grey Hose Bard Fitting	1
37	80-0101	3/4" Check Valve	1
38	80-0104	Strain Relief for Sump Pump	2

10.0 Recovery Tank Schematic Drawing

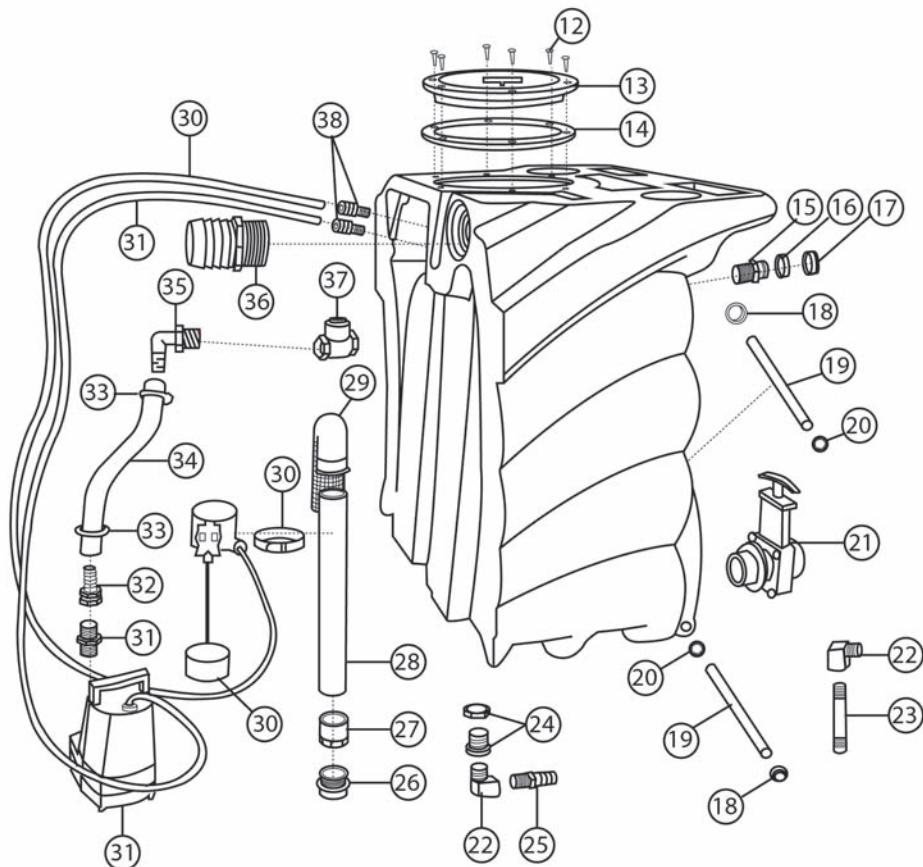

5.0 Set-Up and Operation

5.1 Electrical Cords

Two (2) 25-foot power cords are supplied with your Hard Surface Extractor. Cord 1 powers both vacuum motors and Cord 2 powers the high pressure solution pump and waste pump. The amperage required by each cord requires that the two (2) cords be plugged into separate circuits.

- **Cord 1 (left side):** will require a 20 Amp circuit to run both vacuums.
- **Cord 2 (right side):** can be plugged into a 15 Amp circuit if the auto-dump pump-out is not used or a 20 Amp circuit if the auto-dump pump-out is used.

20 Amp circuits are usually found in kitchens and bathrooms. Make sure not other items are plugged into these circuits. An overloaded circuit may not always trip the breaker and may not provide sufficient power to operate the machine. Plug the two (2) cords into two (2) outlets from different circuits.

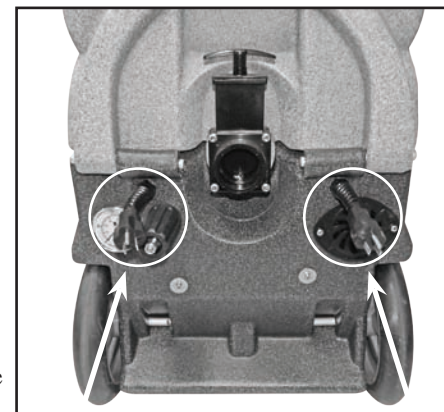

Cord 1 (left side) Cord 2 (right side)

5.2 Water and Chemical Dilution – Auto Fill

The chemical dilution rate is controlled by the metering tip and the dilution rate can only be changed by changing the metering tip (see section “How to Change the Metering Tip” on page 11 for instructions).

Chemical Feed Setup

- Remove the chemical feed hose from the solution tank. Make sure the float is attached to the valve and hanging freely.
- Place the end of the hose into a container of liquid chemical.
- If the tip is removed and the proportioning system operated with no tip, the dilution rate will be 8:1 (the equivalent to adding 16-1/4 oz. of chemical to each gallon of water).
- If a fresh water rinse with no chemical is desired, simply leave the chemical feed hose inside the solution tank.

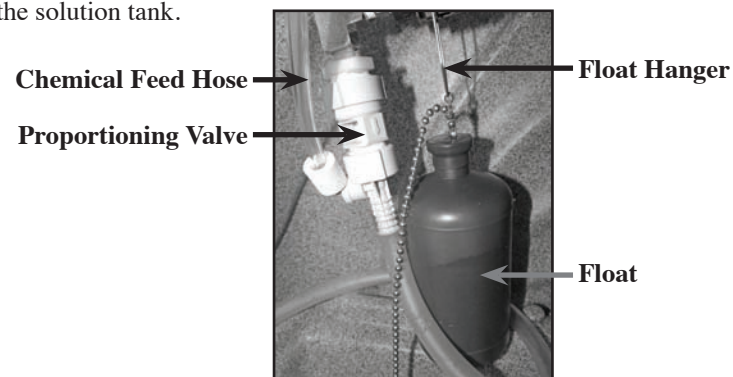

5.0 Set-Up and Operation Continued

5.2 Water and Chemical Dilution – Auto Fill Continued

How to Change the Metering Tip

- Remove the chemical feed hose from the barb on the side of the proportioning valve.
- Unscrew and remove the old tip.
- Screw in the proper tip for your chemical tip and place the hose back on the barb.

Metering Tip Kit

The Metering Tip Kit contains 14 different colored metering tips, allowing dilution rates from 11:1 up to 427:1. Refer to the chart below to select the tip that meets the dilution rate for your chemical application.

- For example, if you require 1-1/2 ounces of chemical per gallon of water, change to the red metering tip with the dilution rate of 85:1.
- The dilution rates are based on chemicals with water-like viscosity. Thicker (more viscous) chemicals will dilute at a different rate.
- DO NOT use powdered chemicals in the machine. Use of powdered chemicals will void your warranty.
- Contact your distributor if you have questions about your chemical.

Metering Tip Chart

Tip Color	Chemical Dilution Rates	
	Oz. / Gal.	Ratio
Tan	0.30	427:1
Orange	0.40	320:1
Turquoise	0.50	256:1
Pink	0.75	170:1
Light Blue	1.00	128:1
Brown	1.12	114:1
Red	1.50	85:1
White	1.75	73:1
Green	2.00	64:1
Blue	2.50	51:1
Yellow	3.75	34:1
Black	5.00	26:1
Purple	8.50	15:1
Gray	11.50	11:1
No Tip	16.25	8:1

9.0 Solution Tank Parts List

Drawing No.	Item No.	Description	Quantity
1	10-0870	1/4" Male QD	1
2	80-0011-2	90 Degree Street Elbow	3
3	10-0868	1/4" Femal QD	1
4	10-0846	1/4" MPT Hex Nipple	2
5	10-0852	1/4" 90 Degree Brass Elbow	1
6	80-0032	3/8" Bulk Head Fitting	2
7	10-0845	1/4" Strainer	1
8	10-0400-C	Latch for Extractor	1
9	10-0379	8-32 x 3/8" Screws	2
10	80-0107	DEMA Valve	1
11	80-0115-B	3/8" MPT x 1/2" Barb Brass	1

9.0 Solution Tank Schematic Drawing

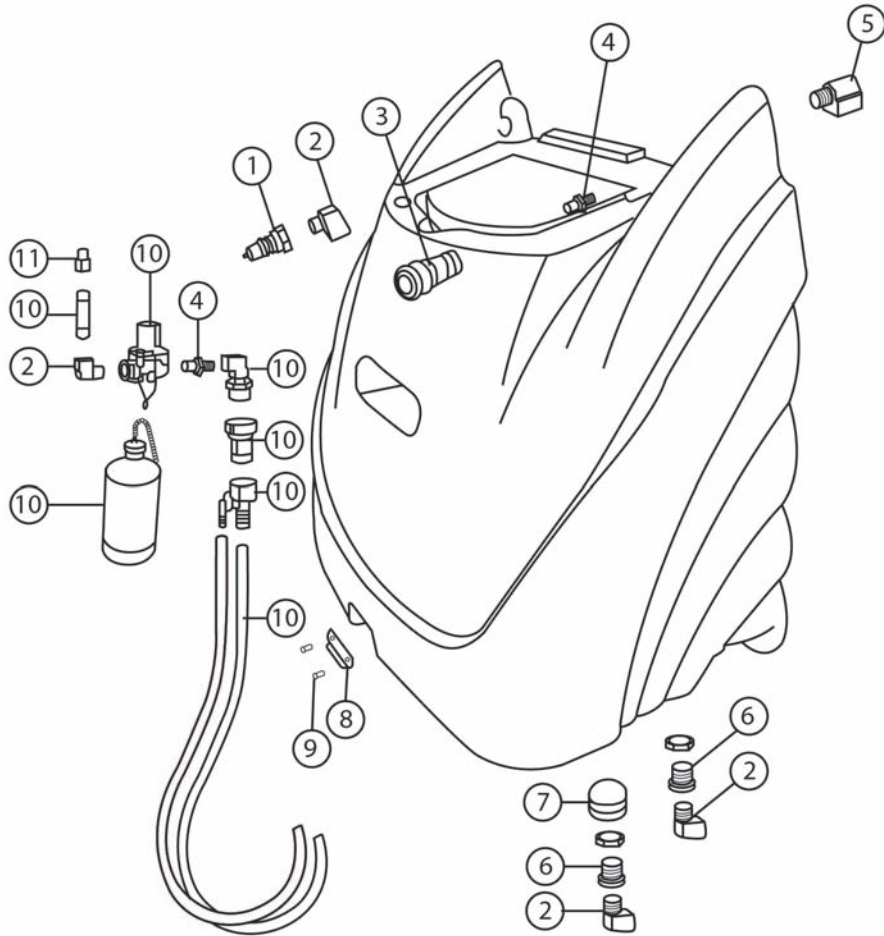

5.0 Set-Up and Operation Continued

5.2 Water and Chemical Dilution – Auto Fill Continued

Water Supply

Once the correct metering tip is in place:

- Connect the auto-fill water supply hose to the water inlet (the male QD on the front of the machine).
- Connect the other end of the hose to a water faucet and then turn the water ON.
- Hot water can be used as long as it does not exceed 140 degrees Fahrenheit.

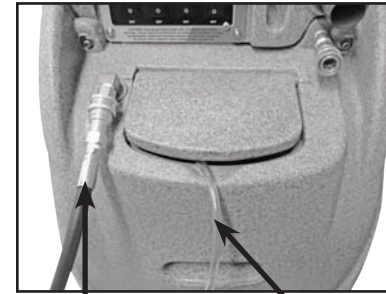

Chemical Feed Hose

Connect the auto-fill water supply hose to solution inlet (male QD on the front of the machine).

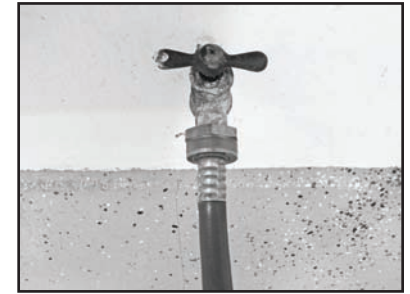

Connect the auto-fill water supply hose to a faucet and turn water ON.

5.3 Connection of Solution Hose

Connect the high pressure solution hose to the solution outlet (female QD on the front of the machine). Connect the other end of the hose to the male QD on the cleaning tool. When you are ready to start cleaning, turn the solution pump switch to the ON position.



HP Solution Hose Assembly
Part No. 80-0502
25-Foot with Male and Female Quick Disconnects

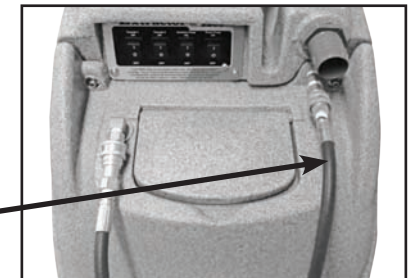

Connect the male end of the HP solution hose assembly to the female solution outlet fitting on the machine. Connect the female end to the cleaning tool.

5.0 Set-Up and Operation Continued

5.4 Power Priming the High Pressure Pump

Once water is in the solution tank, the high pressure pump must be primed:

- Turn ON both vacuums then the solution pump. The vacuum will pull solution through the pump and prime valve into the vacuum tank.
- Place the end of priming hose inside the vacuum hose barb.
- Cup a hand around the hose and barb to increase the vacuum suction on the hose. When the pump is primed, you will hear the pulsation of the pump change.
- After priming, turn OFF the solution pump. If you have not yet connected your solution hose or tool, you may have to relieve the pressure in the line so you can connect your hose or tool.



If the pump still does not prime or if flow is low or unsteady, check the hose from the solution tank to the pump (as well as the filter) for clogging, kinks or restrictions. Clean or replace hose and/or filter and repeat the priming process.

If you are having trouble with the pump, refer to the “Trouble Shooting Guide” section or contact your distributor for advice or assistance.

5.5 Connection of Vacuum Hoses

There are three (3) components used to connect the cleaning tool to the vacuums and recovery tank:

- 1. 4-Foot Vacuum Hose:** connected to the vacuum barb on the front of the machine and to the outlet side of the clear view in-line filter.
- 2. Clear View In-Line Filter**
- 3. 25-Foot Vacuum Hose:** the 2” cuff on the 25-foot vacuum hose is connected to the inlet side of the clear view in-line filter. The other end with the 1-1/2” cuff is connected to the cleaning tool.

When ready to begin cleaning, turn both vacuum switches to the ON position. While the Hard Surface Extractor can operate with only one (1) vacuum for cleaning delicate fabrics, in most situations you will turn both vacuums switches to ON.



Short Vacuum Hose with Cuffs
2” x 4-Feet with 2” Cuffs

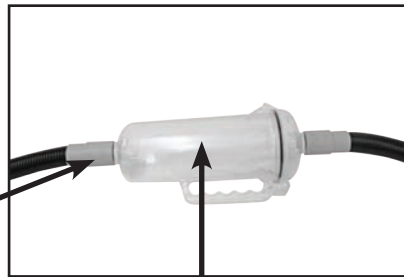

Vacuum Hose
2” x 25-Feet with 2” Cuffs

8.0 Trouble Shooting Guide Continued

Never operate the Hard Surface Extractor when the equipment is not performing as expected or when any part is visibly damaged. When repair is needed, take the equipment to an authorized service center.

Problem	Possible Cause	Remedy
Loss of Vacuum	<ol style="list-style-type: none"> 1. Vacuum motor faulty 2. Vacuum motor gasket damaged 3. Recovery tank lid gasket damaged 4. Dump valve open 5. Dump valve leaking 6. Vacuum motor hoses loose/leaking 7. Vacuum hose or tool clogged 8. Vacuum hoses or cuffs leaking 9. Recovery tank full 10. Float shut-off filter clogged 11. Ball stuck in float shut-off 12. Auto-dump pump-out check valve stuck open 13. Recover tank damaged 	<ol style="list-style-type: none"> 1. Replace vacuum motor 2. Replace gasket 3. Replace gasket 4. Close valve 5. Repair or replace dump valve 6. Reconnect or replace vacuum motor hoses 7. Clean out vacuum hoses and tool 8. Replace vacuum hoses, cuffs and connectors as needed 9. Drain tank 10. Clean float shut-off filter 11. Repair or replace float shut-off 12. Clean out or replace check valve 13. Replace recovery tank
Chemical not Feeding	<ol style="list-style-type: none"> 1. Solution tank not filling 2. Chemical hose restricted 3. Filter screen plugged 4. Low incoming water pressure 5. Wrong size metering tip 6. Chemical proportioner faulty 7. Check valve in filter faulty 	<ol style="list-style-type: none"> 1. Check and repair auto fill assembly 2. Un-kink, shorten, clean out or replace hose 3. Clean or replace filter 4. Set chemical bottle on top of machine – shorten chemical hose – find other water source 5. Change metering tip 6. Replace chemical proportioner 7. Replace filter
Tool won't Spray – Low or Uneven Spray	<ol style="list-style-type: none"> 1. Jets clogged 2. In-line filter clogged 3. Jets worn 4. Jets not aligned properly 5. Tool valve faulty 6. Quick disconnects or hoses restricted 	<ol style="list-style-type: none"> 1. Clean out or replace jets 2. Clean out or replace filter 3. Replace jets 4. Re-align jets 5. Repair or replace valve 6. Clean out or replace quick disconnects and/or hoses
Solution Tank not Filling	<ol style="list-style-type: none"> 1. Water source turned off 2. Float not on valve arm 3. Float valve faulty 4. Water hose restricted 5. Quick disconnects faulty 	<ol style="list-style-type: none"> 1. Turn on faucet or find other water source 2. Reconnect float to valve arm – adjust to proper height/level 3. Repair or replace float valve 4. Un-kink, clean out or replace hose 5. Clean out or replace quick disconnects
Solution Tank Overflowing	<ol style="list-style-type: none"> 1. Float too heavy/filled with water 2. Float and chain tangled 3. Float too high 4. Float valve faulty 	<ol style="list-style-type: none"> 1. Replace float 2. Make sure float chain free and hanging properly 3. Adjust chain to set float at proper level 4. Repair or replace float valve
Chemical Jug Filling with Water – Overflowing	<ol style="list-style-type: none"> 1. Foot valve in filter stuck 2. Foot valve in filter faulty 	<ol style="list-style-type: none"> 1. Clean out foot valve and filter 2. Replace foot valve and filter
<p>To reduce the risk of fire, electrical shock or injury, repairs to wiring should only be performed by experienced service technicians. If you are not experienced in checking electrical wiring, contact your nearest authorized service center to perform tests and repairs to wiring and switches.</p>		

Contact your distributor for additional troubleshooting assistance, to order parts or for advice and assistance in performing necessary repairs.

8.0 Trouble Shooting Guide

Never operate the Hard Surface Extractor when the equipment is not performing as expected or when any part is visibly damaged. When repair is needed, take the equipment to an authorized service center.

Problem	Possible Cause	Remedy
Machine Not Turning On – No Power	<ol style="list-style-type: none"> 1. Building circuit breaker tripped 2. Faulty power cord 3. Faulty switches or internal wiring 	<ol style="list-style-type: none"> 1. Reset breakers or move cords to other outlets 2. Replace power cord 3. Check wiring and test switches – repair as needed
Solution Pump not Running	<ol style="list-style-type: none"> 1. Building circuit breaker tripped 2. Pump circuit breaker tripped 3. Faulty power cord 4. Faulty switches or internal wiring 5. Pump motor breaker tripped 6. Pump motor faulty 7. Pump seized – trips breaker 	<ol style="list-style-type: none"> 1. Reset breakers or move cords to other outlets 2. Reset breaker – check available circuit power and pump 3. Replace cord 4. Check wiring and test switches – repair as needed 5. Push in reset button on pump motor and/or external breaker 6. Replace pump motor 7. Repair or replace pump head and bearing – check motor and/or replace complete pump and motor assembly
Low Solution Pressure and/or Pulsation	<ol style="list-style-type: none"> 1. Jets too large for pressure desired 2. Jets worn allowing too much flow 3. Solution inlet filter plugged 4. Hose from solution tank restricted 5. Pump intake hose or fittings leaking 6. Pressure regulator sticking 7. Pressure regulator faulty 8. Filter screen or jets plugged on tool 9. Solution tank empty 10. Pump not primed 11. Pump faulty 12. Pressure gauge faulty 13. Tool valve faulty 14. Quick disconnects or hoses restricted 	<ol style="list-style-type: none"> 1. Check jet size and flow rates – use smaller jets or lower pressure 2. Replace jets 3. Clean or replace filter 4. Repair or replace hose 5. Repair or replace hose – tighten clamps or replace fittings 6. Lube o-rings on regulator shaft 7. Repair or replace pressure regulators 8. Clean out filter or jets 9. Add water to tank – check and repair auto fill assembly 10. Perform pump priming procedure 11. Repair or replace pump 12. Replace gauge 13. Repair or replace valve 14. Clean out or replace quick disconnects and/or hoses
Can't Connect Solution Hose to Machine	<ol style="list-style-type: none"> 1. Pressure in lines 2. Quick disconnects faulty 3. Wrong style/size quick disconnects 	<ol style="list-style-type: none"> 1. Replace pressure 2. Replace quick disconnects 3. Replace quick disconnects to match connects on machine
Auto-Dump Pump-Out not Working	<ol style="list-style-type: none"> 1. Building circuit breaker tripped 2. Faulty power cord 3. Faulty switches or internal wiring 4. Auto-dump pump-out pump faulty 5. Auto-dump pump-out pump clogged 6. Outlet check valve stuck 7. Discharge hose restricted 8. Float switch stuck 9. Float switch faulty 	<ol style="list-style-type: none"> 1. Reset breakers or move cords to other outlets 2. Replace cord 3. Check wiring and test switches – repair as needed 4. Replace auto-dump pump-out pump 5. Clean auto-dump pump-out – keep recovery tank clean – use hydro-filter 6. Clean or replace check valve 7. Un-kink, clean-out or replace hose 8. Clean switch – make sure float slides up and down easily 9. Replace float switch
Vacuum Motor not Running	<ol style="list-style-type: none"> 1. Building circuit breaker tripped 2. Faulty power cord 3. Faulty switches or internal wiring 4. Vacuum motor faulty 	<ol style="list-style-type: none"> 1. Reset breakers or move cords to other outlets 2. Replace cord 3. Check wiring and test switches – repair as needed 4. Replace vacuum motor

To reduce the risk of fire, electrical shock or injury, repairs to wiring should only be performed by experienced service technicians. If you are not experienced in checking electrical wiring, contact your nearest authorized service center to perform tests and repairs to wiring and switches.

5.0 Set-Up and Operation Continued

5.6 Connection of Auto-Dump Hose

The auto-dump hose is a 50-foot section of a 3/4" garden hose.

- Remove the cap from the auto-dump outlet fitting on the back of the machine.
- Connect the auto-dump hose to the outlet fitting.
- Place the other end of the hose in a commode or drain connected to a sanitary sewer system.
- Secure the hose end to prevent movement during pumping.

Use defoamer to prevent foam build-up in the recovery tank during cleaning and to keep foam/moisture from entering vacuums.



**50-Foot Auto-Dump Hose
Part No. 80-0112**

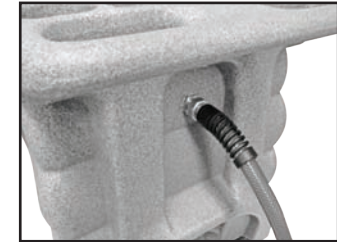

If not using the auto-dump feature, the auto-dump hose does not need to be connected. When the recovery tank fills during cleaning, the float ball assembly in the vacuum inlet filter will rise and will automatically shut-off the vacuum air flow to prevent the recovery tank from overflowing and waste from getting into the vacuums. When this occurs:

- Immediately turn OFF the vacuum switches.
- Drain the recovery tank. Turn OFF the pump switch while draining the tank. Turn pump switch back ON upon resumption of cleaning.
- Close the dump valve and turn the vacuum switches back ON when ready to resume cleaning.

If the auto-dump or vacuum shut-off is not working properly, refer to the "Trouble Shooting Guide" section or contact your distributor for advice or assistance.

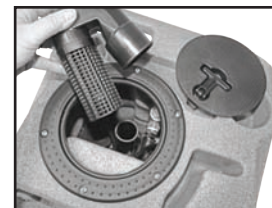

**Float Assembly
Part No. 80-0012**



Drain Recovery Tank

5.0 Set-Up and Operation Continued

5.7 Adjusting the Pressure

When the high pressure solution pump is on and primed, pressure will show on the gauge only while the tool is being sprayed. When the tool is sprayed, the gauge will display the pressure being delivered to the tool. When the tool is not being sprayed, the gauge will return to zero.

- To decrease the pressure, turn the black knob on the pressure regulator to the left (counter-clockwise).
- To increase pressure, turn the black knob on the pressure regulator to the right (clockwise).
- To adjust pressure to your tool and surface requirements: spray the tool; check the pressure on the gauge; re-adjust as needed to set the machine at the desired pressure; choose the pressure setting that best meets your type of cleaning.

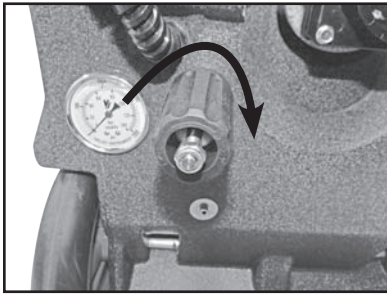

To increase solution pressure, turn the regulator knob clockwise.

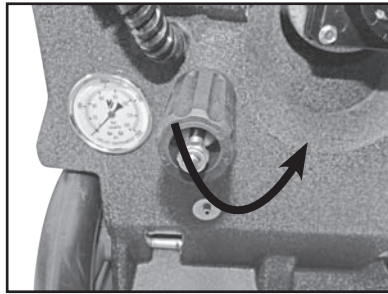

To decrease solution pressure, turn the regulator knob counter-clockwise.

The maximum pressure setting is 1200 PSI. However, the highest pressure attained is dependent on the amount of water flow at the tool:

- Smaller jets and lower flow will allow for higher pressure at the tool.
- Larger jets and higher flow will lower the maximum pressure attained at the tool.

The desired setting will depend on the type of cleaning and tool used. For example:

- Carpet Cleaning with 2-Jet Wand: 400 PSI
- Tile Cleaning with Hard Surface Tool: 1000 PSI

If adjusting or maintaining pressure becomes a problem, refer to the “Trouble Shooting Guide” section or contact your distributor for advice or assistance.

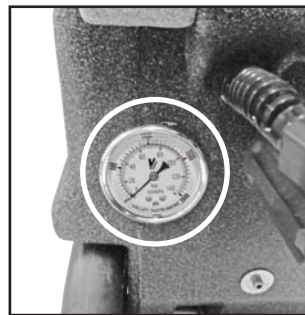

7.0 Maintenance Continued

7.13 WD-40 Vacuum Motors

Should moisture ever enter the vacuum motors, completely drain the recovery tank, open the recovery tank lid, remove the vac shut-off assembly, turn on both vacuum motors and spray a burst of WD-40 into the standpipe. Continue to run the vacuum motors for at least three (3) minutes. To prevent moisture from damaging the vacuum motors during storage, empty the recovery tank and store with the lid open.

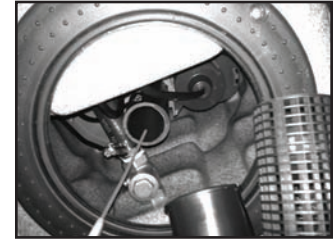

7.14 Prevent Mineral Deposit Build-Up

Vinegar may be used to prevent mineral deposit build-up in your machine's lines and pump. Failure to do so may clog your lines and pump. Every two weeks, pour vinegar into the solution tank (dilute with 1/2 water). Run the pump, while squeezing your wand or upholstery tool's trigger unit you smell vinegar or notice it coming out of the tool. Let the machine sit overnight, and no longer, with the vinegar in its lines. The next day, flush the machine with 1-gallon of clean water or until you do not smell vinegar any longer.

PLEASE NOTE: If you choose to use CLR, follow the directions on the bottle. **DO NOT** leave CLR in the machine's lines and flush thoroughly. CLR may corrode the machine's components and **VOID** your warranty. If you choose to use vinegar, you **MUST** dilute with 1/2 water. Failure to do so may damage the machine's components and **VOID** your warranty.

7.0 Maintenance Continued

7.11 Clean In-Line Pump Filter

CAUTION: before proceeding with this procedure, make sure both the power cords are disconnected.

- Unlatch the base of the machine and tip the tanks back.
- Carefully expose the in-line filter in the motor base. Unscrew the clear H2O cup.
- Remove the screen from the cup. Be careful not to bend the screen.
- Rinse both the screen and cup with fresh water.
- Reassemble the H2O filter and replace it carefully into the motor base.
- Lift the tanks back onto the base and restore the latch.

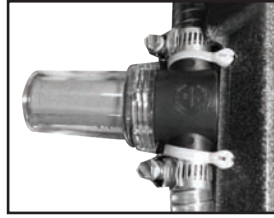

IMPORTANT: this filter must be cleaned at least once a week to prevent water blockage to the pump.

7.12 Flush Chemical System

Chemical build-up in the chemical system can prevent the system from drawing chemical.

- Rinse the chemical system with fresh water (for heavy chemical build-up, a mild acid can be added to the rinse water).
- Remove the chemical feed hose from the solution tank and place the end of the chemical feed hose into water or mild acid solution.
- Connect the auto-fill water supply hose to the water inlet (male quick disconnect) on the front of the machine.
- Connect the other end of the hose to a water faucet and turn ON the water. Let the water flow into the tank until you are sure the rinse solution has been drawn through the proportioner and mixed with the incoming water. The metering tip can be removed from the proportioner to speed up the process.
- Once the rinse solution has been drawn through the proportioner, turn OFF the water faucet and disconnect the auto-fill water supply hose.
- Plug in Cord 1 (left side), connect the short 4-foot vacuum hose to the vacuum barb, turn on one or both vacuums and use the short vacuum hose to remove the water from the solution tank.
- When the solution tank has been emptied, turn OFF the vacuums and unplug the power cord.
- Place a bucket under the dump valve and open the dump valve to drain the water from the recovery tank.
- Close the dump valve and dispose of the water.



5.0 Set-Up and Operation Continued

5.8 Switch Panel



Vacuum 1 – Power from Cord 1

When the switch is turned to the ON position, power is supplied to the vacuum motor (3-Stage Vacuum).

Vacuum 2 – Power from Cord 1

When the switch is turned to the ON position, power is supplied to the vacuum motor (2-Stage Vacuum).

Solution Pump Switch – Power from Cord 2

When the switch is turned to the ON position, power is supplied to the solution pump motor (Extracting Only). DO NOT turn this switch ON.

Waste Pump Switch – Power from Cord 2

When switch is turned to the ON position, waste pump operation is controlled by the float switch in the recovery tank. Pump will remain OFF until water level rises to the point at which the float switch will turn the waste pump ON. DO NOT turn waste pump switch ON unless a hose is connect to the pump-out outlet port.

6.0 Shutdown Procedures

- If using the auto-fill system, turn the water supply OFF before finishing each job. This will allow use of the water and chemicals already in the tank and will reduce the amount of excess water to be disposed of later.
- When finished cleaning, turn OFF all switches.
- If the auto-fill system was used and there is still water in the solution tank, push the float down to release the water inlet hose pressure before disconnecting the hose from the faucet. Disconnect the water inlet hose from the quick disconnect on the front of the machine.
- Disconnect the solution hose and vacuum hose from the cleaning tool. Pull the valve trigger to release pressure from the hose before disconnecting the solution hose from the cleaning tool.
- Disconnect the clear view in-line filter from the vacuum hoses and clean the filter as needed.
- Disconnect the vacuum hose and solution hose from the machine.
- If water remains in the solution tank, use the short vacuum hose and vacuum the excess water from the tank.
- If the auto-fill system was utilized, place the chemical feed hose back into the solution tank.
- If the auto dump-out system was used: turn the waste pump switch ON to pump out any remaining water from the recovery tank; turn switch OFF, remove the auto-dump pump-out hose from the outlet fitting and replace the cap; roll up the hose toward drain to remove the remaining water from the hose; connect ends of hose together to prevent dirty water from dripping from hose during transport.
- Disconnect the power cords from the outlets and from the machine.
- Remove the float shut-off assembly from the recovery tank and clean filter as needed. Replace shut-off assembly and tank lid.
- Drain any remaining water from the recovery tank and dispose of in a sanitary drain. **DO NOT** use the same bucket to drain the tank that you used to fill the tank.
- Roll up all hoses and tools. Collect and store extractor, all tools and accessories.

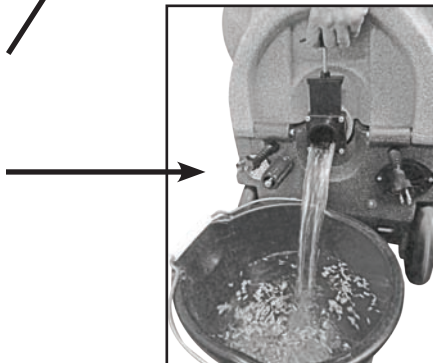
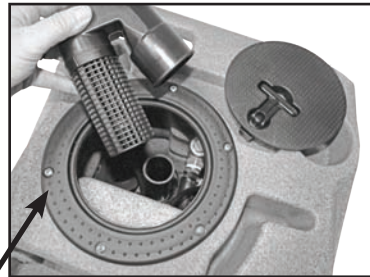
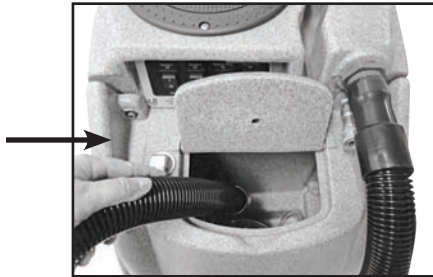

7.0 Maintenance Continued

7.9 Clean Waste Pump

Build-up of fine silt inside the waste pump can clog the pump even if the pump is not used, so this maintenance procedure should be performed regardless of whether the waste pump out has been used.

After cleaning the recovery tank, remove the cap and connect the green 3/4" x 50-foot garden hose to the auto-dump pump-out port located on the back of the machine. Secure the other end of the hose where you wish to direct the discharge of waste water, such as a toilet or sink.

Fasten the discharge end of the hose tightly. With Cord 2 (right side) plugged in, turn the recovery tank switch to the ON position. Use a hose to fill the recovery tank to a point where the float switch turns the waste pump ON. The pump will turn on automatically when water in the recovery tank is approximately 2/3rds full. The pump will discharge the waste water down to a level of about 2 inches in the recovery tank. Let the pump run until it pumps the level down to a point when the float switch shuts OFF the auto-dump pump.

DO NOT turn on the auto-dump out switch without the dump hose in place. Unplug the cord and turn the auto-dump pump switch OFF. Open the dump valve and drain out the remaining water. Close the dump valve, replace the recovery tank lid and dispose of the dirty water and debris. This auto-dump out system has been designed to keep up with flood restoration work and is capable of pumping 10-gallons per minute.

7.10 Clean Pump Inlet Filter

A restricted pump inlet filter can prevent the solution pump from providing adequate pressure for cleaning. A restriction of air leak on the pump inlet hose can also damage the solution pump check valves and plunger seals.

CAUTION: before proceeding with this procedure, make sure both power cords are disconnected.

- To examine the filter, open the solution tank lid on the front of the machine. The filter is in the base of the solution tank.
- Grasp the filter cap and unscrew the filter from the brass nipple by turning counter-clockwise. Clean or replace the filter as needed.
- To examine the pump inlet hose, release the latch on the front of the machine and tilt the tanks off of the base assembly. Support the tanks with a chair, bucket or box while working inside the base.
- Examine the hose for kinks, clogs or holes and repair or replace the hose as needed.
- Tilt the tanks back onto the base and secure the latch.

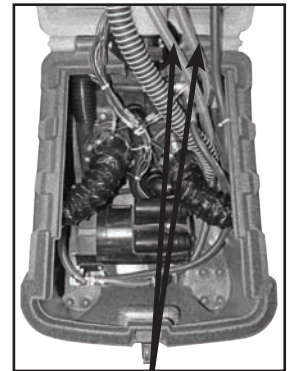

Pump Inlet Hoses



**1/4" Acorn Strainer
Part No. 10-0845**

7.0 Maintenance Continued

7.8 Flush Solution Tank and Pump Continued

- Let the pump run until most of the water has been pumped out of the solution tank. DO NOT let the pump run dry. Turn the pump OFF before the water gets to the bottom of the tank.
- Turn the vacuums OFF and disconnect the prime hose.
- Close the dump valve and dispose of water.
- If there is heavy chemical build-up in the machine, hoses or tools, a mild acid can be added to the rinse water in the previous procedure.
- After the pump has been primed, turn the solution pump switch OFF and turn the vacuums OFF.
- Remove the prime hose and connect the HP solution hose and tools.
- Turn the solution pump ON and direct the tool spray into a bucket. Let the pump run until most of the water has been pumped out of the solution tank. DO NOT let the pump run dry. Turn the pump OFF before the water gets to the bottom of the tank.
- Disconnect the solution hose and tool.
- Use the 4-foot short section of the vacuum hose to vacuum the remaining acid solution out of the solution tank.
- Pour two (2) or three (3) gallons of clean water into the solution tank.
- Connect the pump prime hose to the solution outlet female quick disconnect.
- Direct the end of the prime hose into the recovery tank vacuum barb.
- Turn one or both of the vacuums ON and turn the solution pump ON. Let the pump run until most of the water has been pumped out of the solution tank. DO NOT let the pump run dry. Turn the pump OFF before the water gets to the bottom of the tank.
- Turn the vacuums OFF and disconnect the prime hose.
- Place a bucket under the dump valve and open the dump valve to drain the water out of the recovery tank.
- Close the dump valve and dispose of the water



Direct the end of the prime hose into the recovery tank vacuum barb.

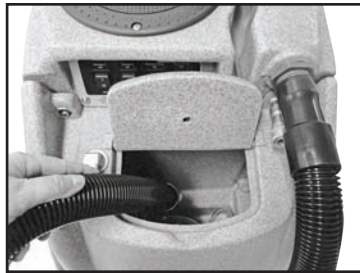

Vacuum solution out of solution tank.

7.0 Maintenance

Regular maintenance is required to keep your Hard Surface Extractor in proper working condition. Failure to properly maintain your machine could void warranty. Thoroughly clean all equipment and accessories after each use.

WARNING: Disconnect electrical power cord before performing any service or maintenance inside the machine base or before testing or repairing switches or power cords. Failure to do so may result in severe personal injury or death.

Operation	Interval
7.1 Clean Chemical Feed Filter	Daily - After Each Job
7.2 Clean Chemical Feed Foot Valve	Daily - After Each Job
7.3 Clean Fresh Water Tank Filter	Daily - After Each Job
7.4 Clean Vac Shut-Off Assembly Screen	Daily - After Each Job
7.5 Clean Clear View In-Line Filter	Daily - After Each Job
7.6 Clean Auto-Dump Pump Out	Daily
7.7 Rinse Out Recovery Tank	Daily
7.8 Flush Solution Tank and Pump	Daily
7.9 Clean Waste Pump	Weekly - As Needed
7.10 Clean Pump-Inlet Filter	Weekly - As Needed
7.11 Clean In-Line Pump Filter	Weekly - As Needed
7.12 Flush Chemical System	Monthly
7.13 WD-40 Vacuum Motors	As Needed

7.1 Clean Chemical Feed Filter

The filter is on the end of the chemical feed hose that is placed in the chemical jug as part of the chemical feed system. Regularly examine the filter and clean as needed.

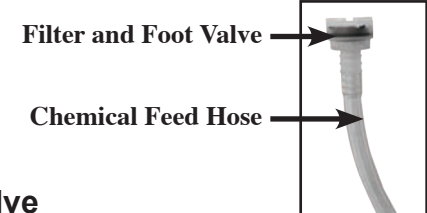

7.2 Clean Chemical Feed Foot Valve

The foot valve is on the end of the chemical supply tube of the automatic chemical feed system. It is necessary to remove the filter from the tubing. Just rinse with fresh water and blow through the valve from the filter side of the barb. If necessary, use a tooth brush and a mild acid rinse to remove detergent build-up. Note, a heavy build-up is a warning sign that the solution system should be flushed. See the “Flush Chemical System” section.

7.3 Clean Fresh Water Tank Filter

The fresh water tank filter is located at the bottom of the solution tank. Unscrew the filter counterclockwise and rinse with fresh water. If necessary, use a tooth brush to remove detergent build-up. Note: a heavy build-up is a warning sign that the solution system should be flushed. See the “Flush Chemical System” section.

7.0 Maintenance Continued

7.4 Clean Vacuum Shut-Off Float Assembly Screen

Inside the recovery tank, on top of the stand pipe, is the vacuum shut-off float assembly. It functions to prevent debris and water from being sucked into the vacuum motors. Operating the Hard Surface Extractor without the shut-off assembly or with a poorly maintained assembly, will greatly decrease the life of the vacuum motors and will void the warranty.

If debris builds up on this filter, it will reduce the vacuum air flow and may cause a significant decrease in the rate of water recovery. If debris prevents the float ball from moving or seating inside the assembly, it may not stop the airflow when the tank fills with water and the water will be sucked in the vacuums and blow out the exhaust.

To clean, twist off the float assembly from the stand pipe and clean the screen. Pull fibers and lint off and rinse with clean water. Push the assembly back onto the stand pipe and replace the recovery tank lid.

This screen should be cleaned frequently if the Hard Surface Extractor is being operated in an environment which has an abnormal build-up of lint and debris, such as cleaning newly installed carpet. Loss of vacuum is most normally associated with lint build-up in this filter at the top of the vacuum stand pipe.

7.5 Clean Clear View In-Line Filter

Build-up of debris in the filter bag of the clear view in-line filter will reduce vacuum air flow and may cause a significant decrease in water recovery. A torn bag will allow debris past the filter and into the recovery tank. This debris can clog the waste pump and the vacuum shut-off assembly. The clear view in-line filter must be examined and cleaned regularly to keep the Hard Surface Extractor functioning properly.

To clean, push the latch lever and open the lid. Remove the filter bag. Examine the bag and clean or replace as needed. Rinse the body of the hydro-filter with clean water. Examine the o-ring seal and replace as needed. Re-install the new or cleaned bag. Close lid and secure latch.

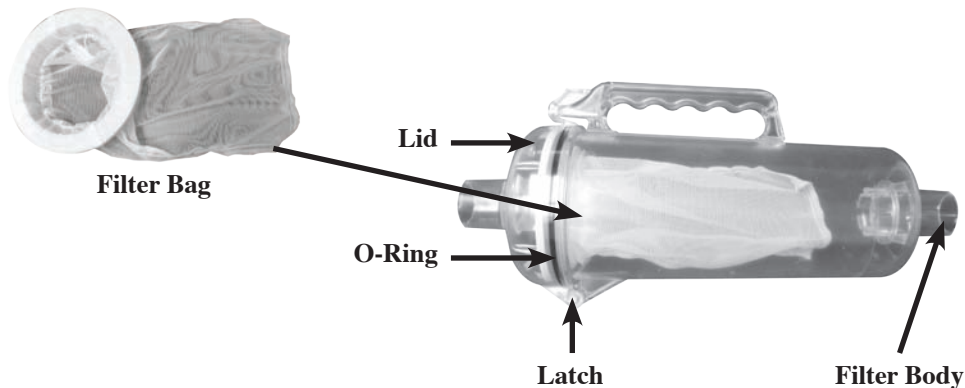

7.0 Maintenance Continued

7.6 Clean Auto-Dump Pump Out

The auto-dump pump-out system is capable of handling most debris that passes through the waste filter. However, for optimum performance, keep the recovery tank clean and remove debris from the filter screen of the auto-dump pump-out. This should be done on a daily basis or as needed, depending upon use and amount of debris.

Every two (2) weeks, run the auto-dump pump-out system with a full tank of clean water to ensure that debris and lint are not accumulating in the base of the pump.

To service the auto-dump pump-out more thoroughly, unhook the vacuum cuff, cut the zip tie around the looped electrical cord and lift it out of the recovery tank. Unsnap the screen from the bottom, clean it and clean out the area inside.

7.7 Rinse Out Recovery Tank

Build-up of fine silt and debris can damage the auto-dump pump and dump valve. Clean out the recovery tank on a regular basis to extend the life of these components as well as keep the tank and machine smelling better.

To rinse out recovery tank, remove the recovery tank lid and open the dump valve. Place a bucket under the dump valve. Use a hose to rinse the dirt and debris out of the recovery tank. Close the dump valve and spray the tank with deodorizer or disinfectant. Proceed to waste pump cleaning and replace the recovery tank lid. Dispose of dirty water and debris.

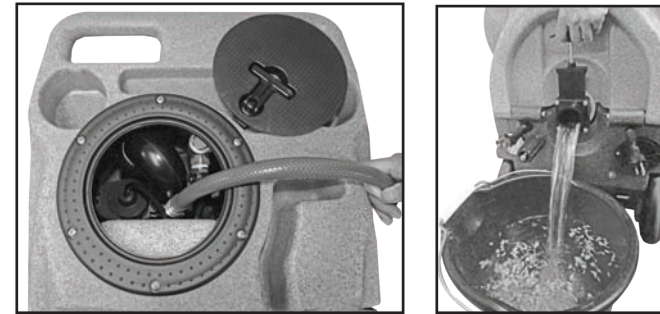

7.8 Flush Solution Tank and Pump

At least once a month, the Hard Surface Extractor hoses and tools should be flushed to remove alkaline residues. Follow the steps of the “Storage and Freeze Protection” section, using a solution of one (1) part warm water with three (3) parts white vinegar in place of the antifreeze solution.

Then, repeat the steps using two gallons of fresh water:

- Pour two (2) or three (3) gallon of clean water into the solution tank.
- With both Cords 1 and 2 plugged in, connect the pump and prime hose to the solution outlet female quick disconnect.
- Direct the end of the prime hose into the recovery tank barb.
- Turn one or both of the vacuums to the ON position and the solution tank to the ON position.