

HARD CLIP DISTORTION

CIR-KIT™ BUNDLE GUIDE



DIY

BY COPPERSOUND PEDALS

INCLUDED COMPONENTS

Potentiometers

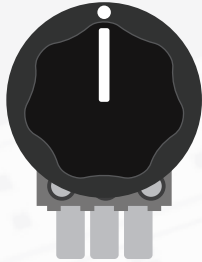

B100K
x1

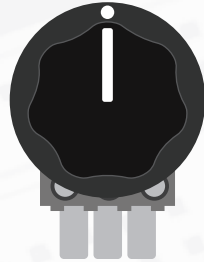

A100K
x2

Precut Wire

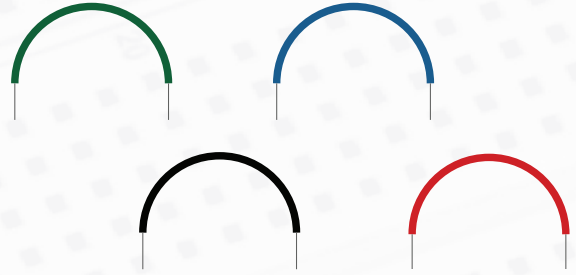

1.5" Red, Black, Green, Blue
x40

Transistors & Capacitors



Film Caps
(various)
x5



Ceramic Caps
(various)
x2

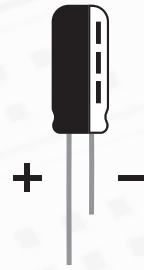

Electrolytic Caps
(various)
x5

Resistors & Diodes



Resistors
(various)
x9



Diode
1n4001
x1



Diode
1n4148
x2

IC's & DIPS



IC
TLO71
x1

BREADBOARD FLOW

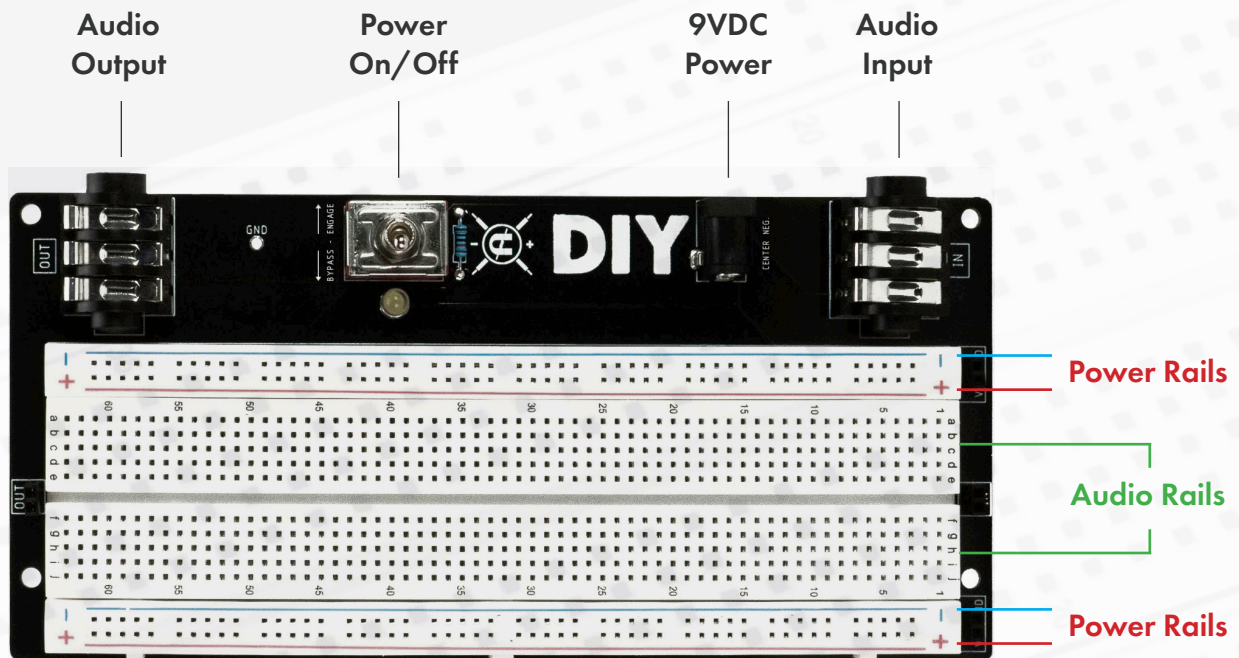

Power rails flow horizontally.

The **negative** rail will connect to the pin header marked **GND**, and the **positive** rail will connect to the pin header marked **VCC**.

Audio rails flow vertically.

Channels **a-e** are connected, and channels **f-j** are connected.

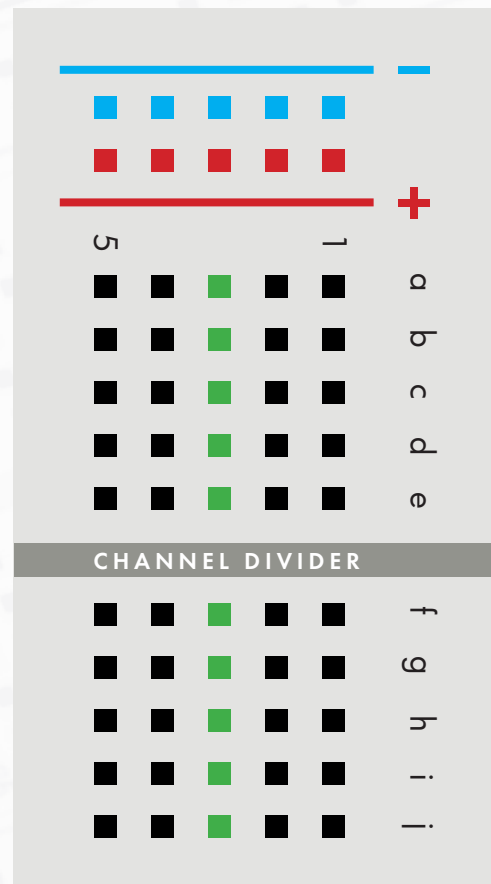

READING RESISTORS

Reading resistors may seem intimidating, but it's a very important aspect of breadboarding and is actually very easy! To determine the resistor value, follow the table and colors below. To ensure you are reading the correct value, keep in mind that the tolerance band is always found on the far right.



COLOR	1ST BAND	2ND BAND	3RD BAND	DECIMAL MULTIPLIER		TOLERANCE
BLACK	0	0	0	1	1	
BROWN	1	1	1	10	10	± 1%
RED	2	2	2	100	100	± 2%
ORANGE	3	3	3	1K	1,000	
YELLOW	4	4	4	10K	10,000	
GREEN	5	5	5	100K	100,000	
BLUE	6	6	6	1M	1,000,000	
VIOLET	7	7	7	10M	10,000,000	
GRAY	8	8	8	100,000,000		
WHITE	9	9	9	1,000,000,000		
GOLD					0.1	± 5%

Shown below are the resistors and values that we'll be using in this build.



47

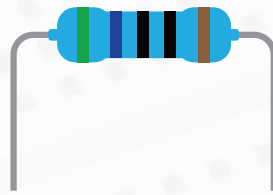

560

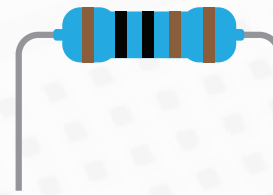

1K

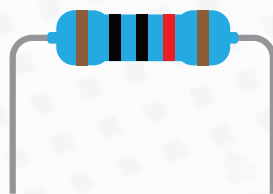

10K

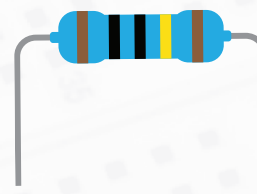

1M

STEP ONE | POWER FILTERING

Power filtering helps to filter unwanted noise from power supplies, while preventing incorrect polarity from damaging the circuit. Ensure that polarized components (diode + electrolytic capacitor) are inserted correctly. In the schematic below, power is shown as 9V, whereas the breadboard shows VCC. Please note that for the majority of pedal circuits, these terms are interchangeable. The two 10K resistors form a divider network, forming reference voltage, or "VR" at 4.5 volts.

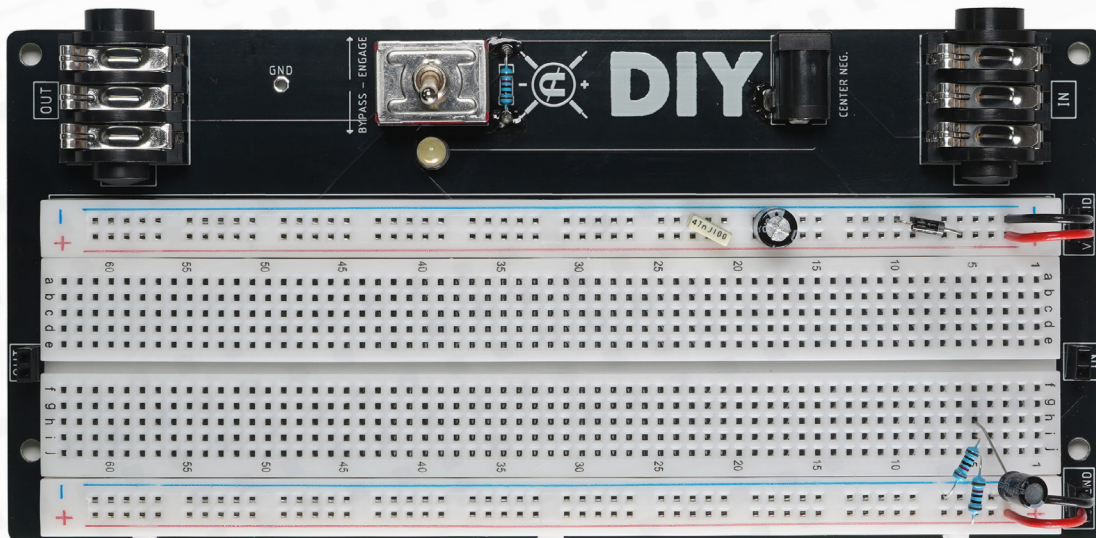
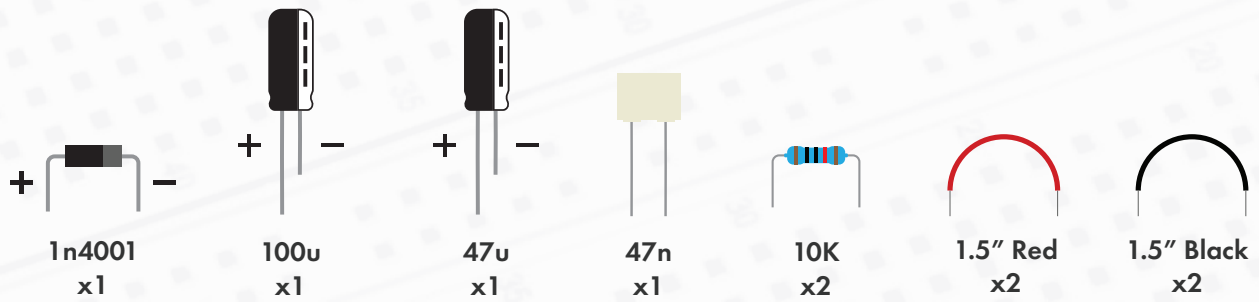
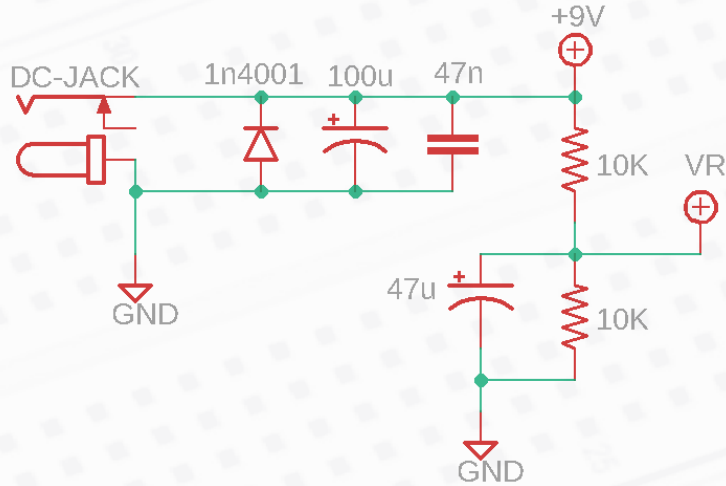

STEP TWO | INPUT

The input capacitor blocks AC signal, while setting the amount of low frequency audio allowed into the circuit. The pull down resistor prevents popping from the switch, and the 1M resistor to VR establishes reference voltage for the circuit.

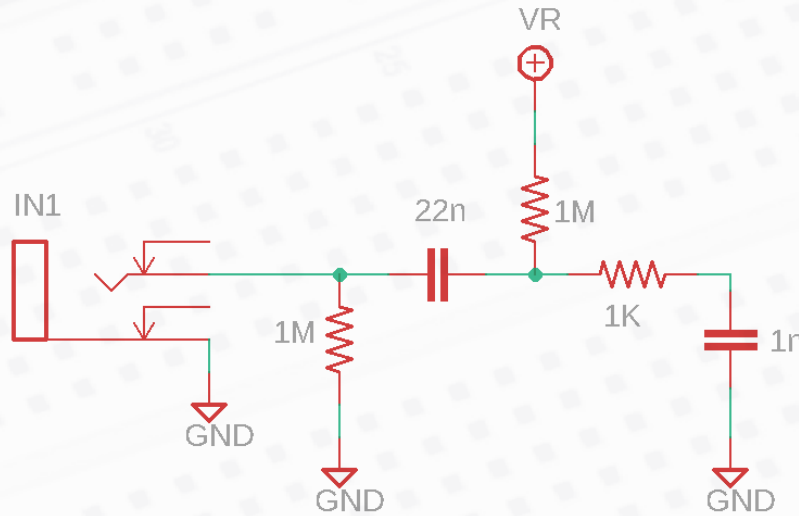

22n
x1



1n
x1



1.5" Green
x3



1.5" Black
x1



1M
x2



1K
x1

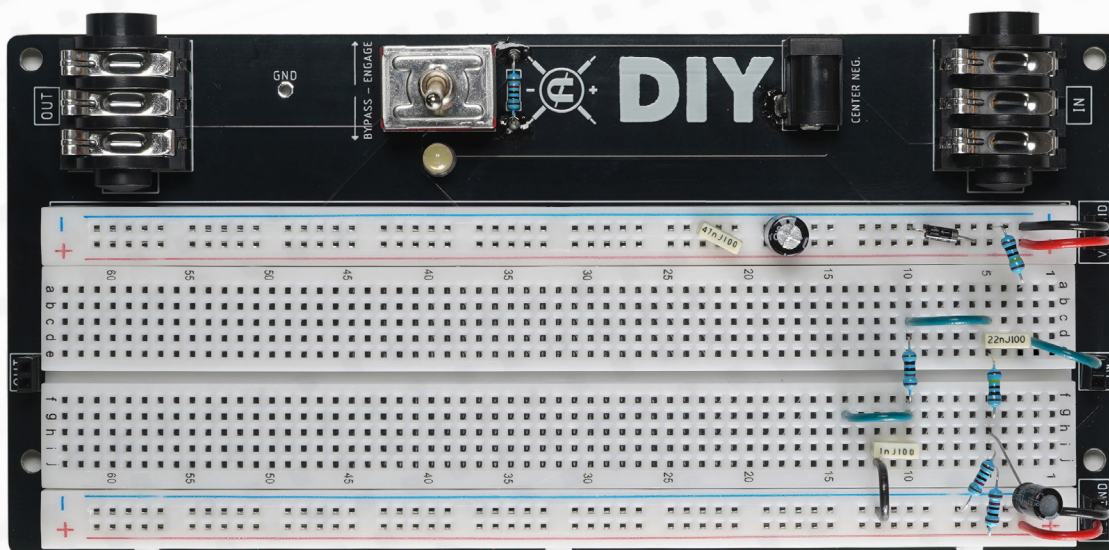

STEP THREE | GAIN STAGE

Signal enters the op amp, and is amplified based on the position of the potentiometer. Some EQing is applied at this stage through the resistors and electrolytic caps to ground.

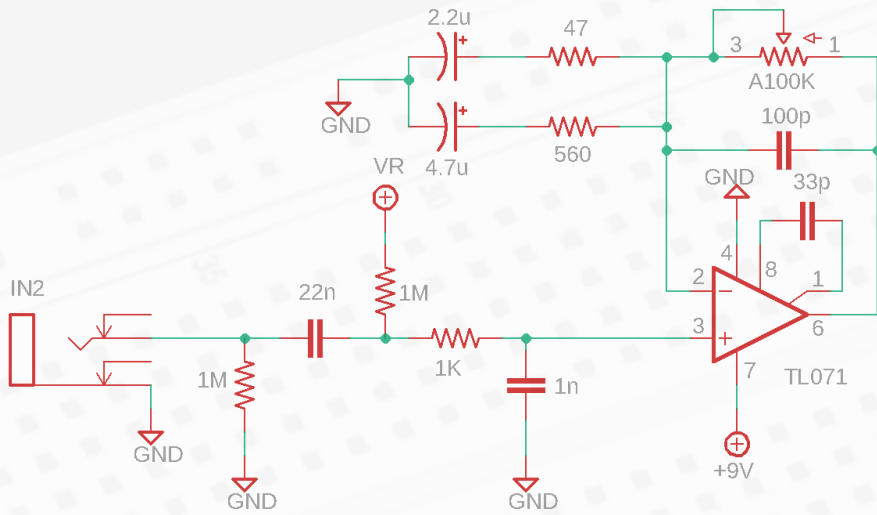

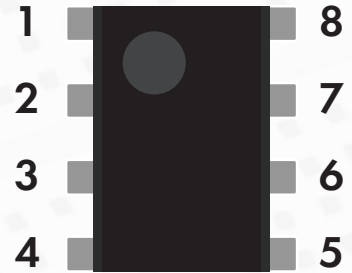

OP AMP PINOUT

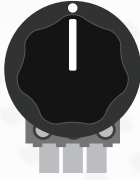



- 

A100K
x1
- 

560
x1
- 

47
x1
- 

TL071
x1
- 

100p
x1
- 

33p
x1
- 

2.2u
x1
- 

4.7u
x1
- 

1.5" Green
x5
- 

1.5" Blue
x2
- 

1.5" Red
x1
- 

1.5" Black
x1

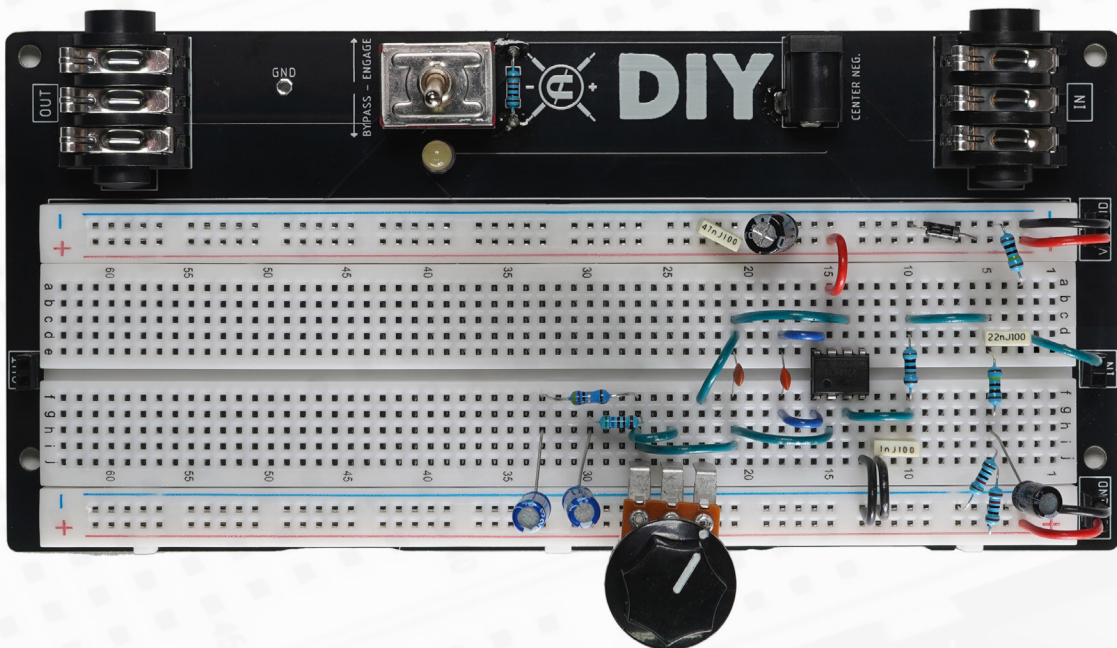

STEP FOUR | CLIPPING SECTION

The symmetrical placement of the two diodes to ground clip both sides of the waveform equally, creating the distorted effect.

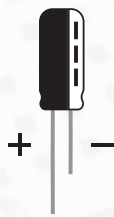
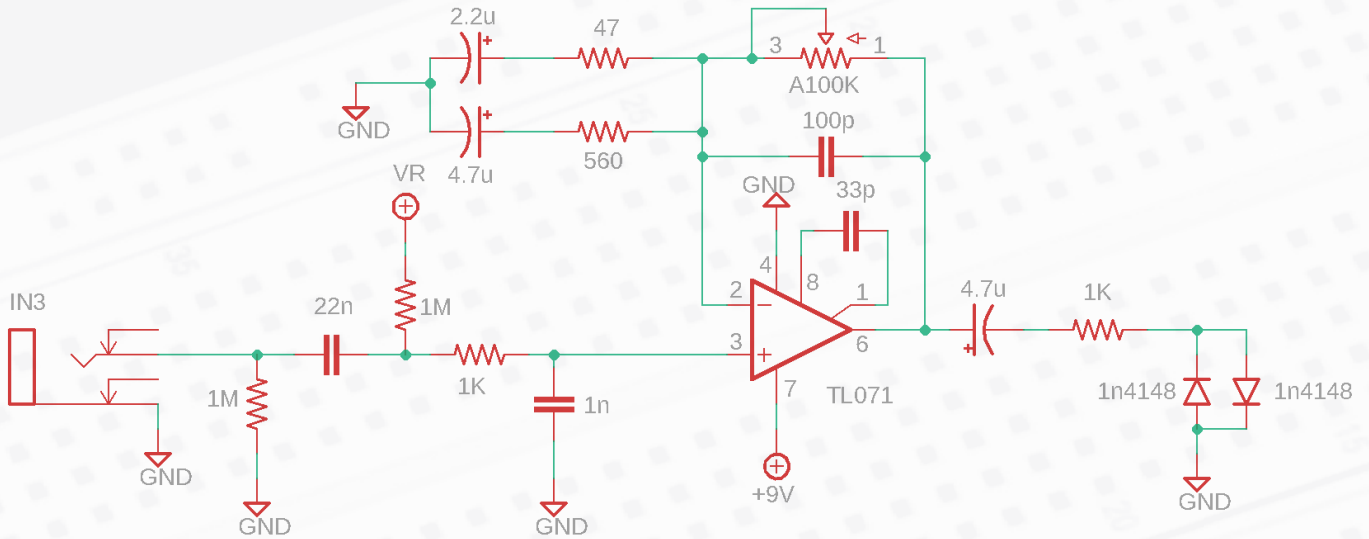

4.7u
x1



1n4148
x2



1K
x1



1.5" Blue
x1

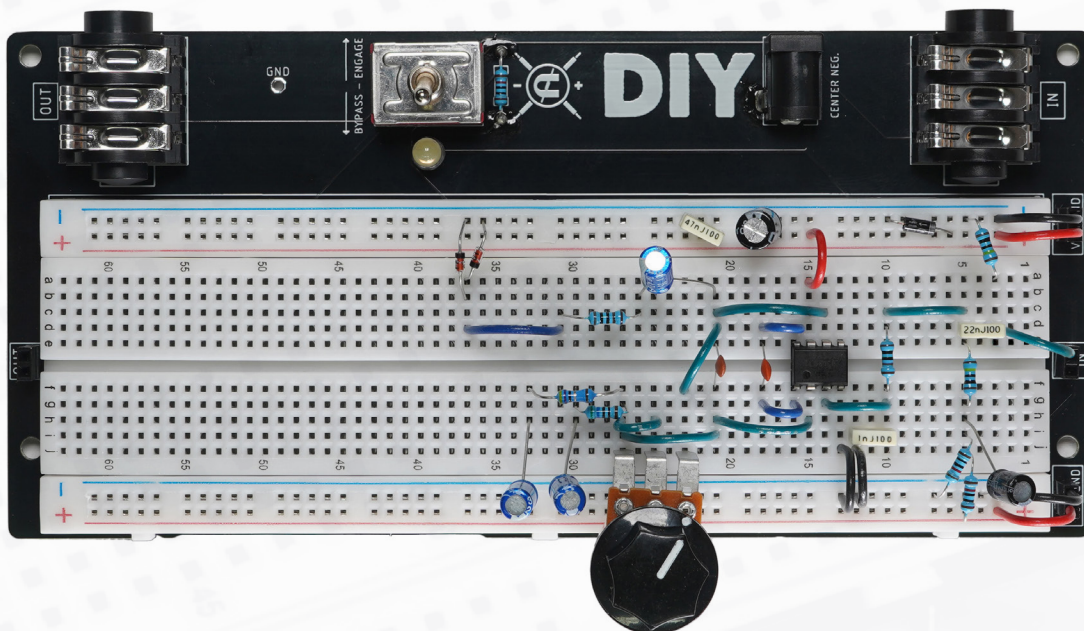

STEP FIVE | TONE NETWORK

In this section, the potentiometer, 1K resistor, and film capacitor create a low pass filter. Rotating the potentiometer counter-clockwise reduces high end content.

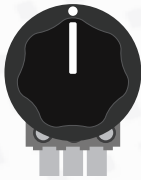
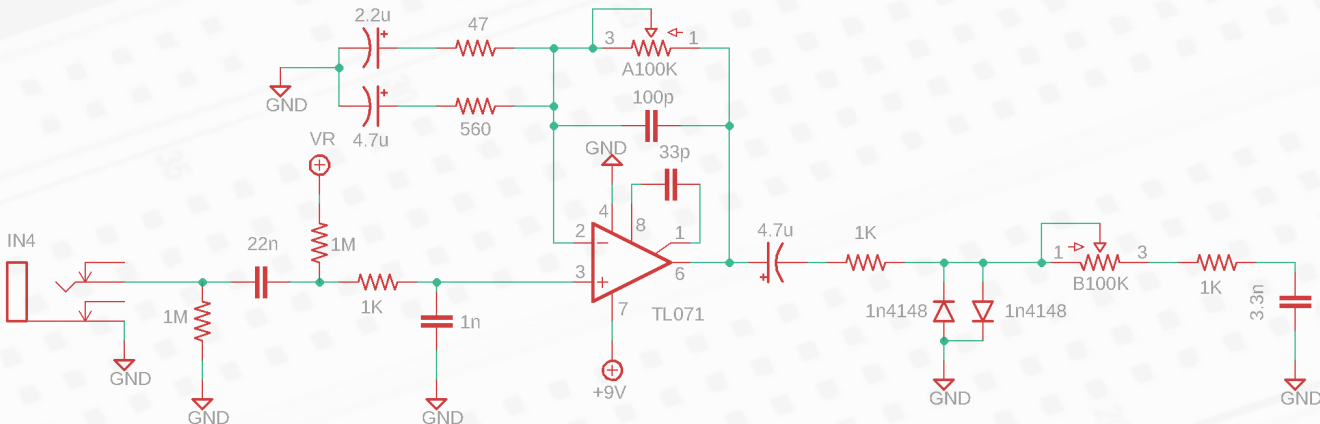

B100K
x1



1K
x1



3.3n
x1



1.5" Black
x1



1.5" Blue
x2

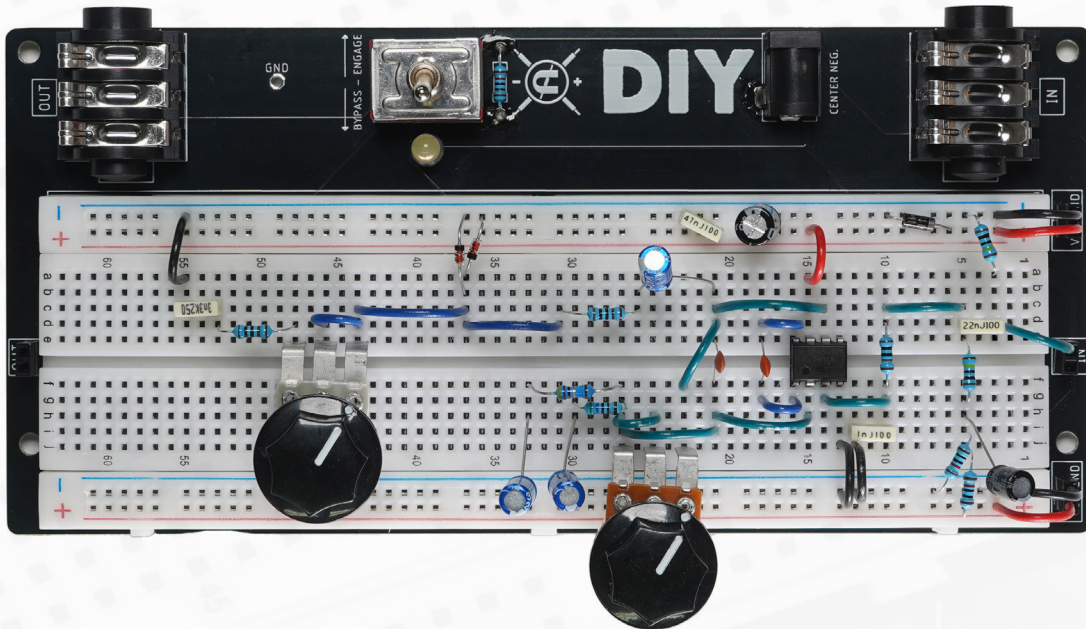

STEP SIX | OUTPUT

The volume knob acts as an attenuator, setting the output volume of the circuit.

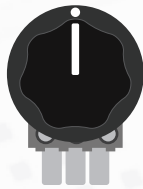
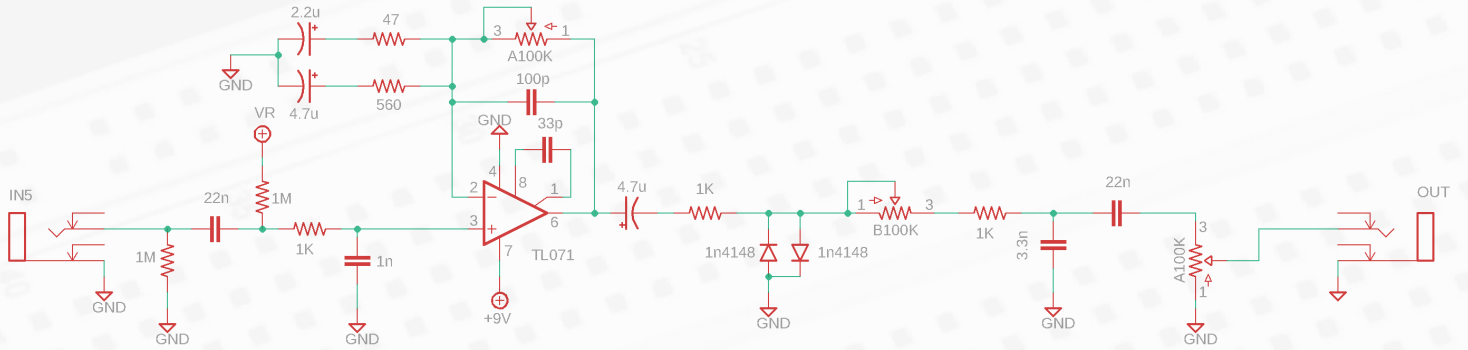

**A100K
x1**



**22n
x1**



**1.5" Green
x1**



**1.5" Black
x1**



**1.5" Blue
x2**

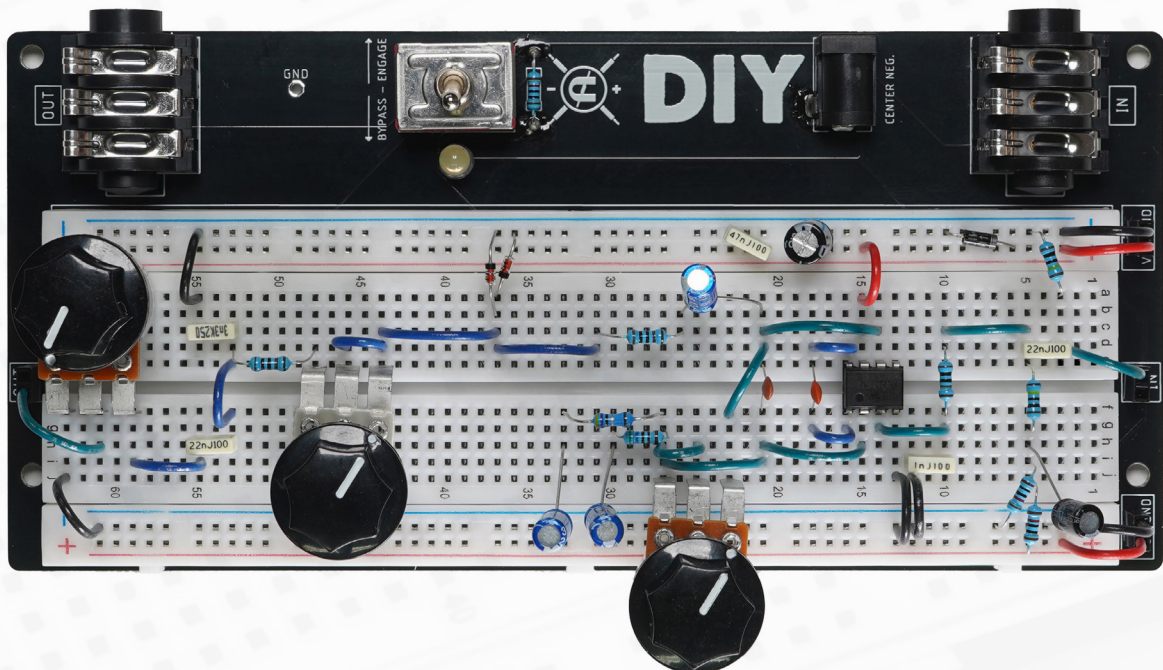

TROUBLESHOOTING

Not getting power to the Power Rails/LED is not turning on when the toggle switch is set to the 'Engage' position.

Check that the proper connections are being made from the "VCC" & "GND" pin headers to the Power Rails. Pay attention to the orientation of Polarized components (Diodes and Electrolytic Capacitors).

Check the polarity of your power supply. Breadboards require "Center negative" polarity (as is with the power supply shipped with the bundle).

Not getting any effect when the toggle switch is set to the Engage position.

Most common issues will pertain to the proper connections being made. This could be as simple as a component being 1 slot away from the correct Audio Rail.

Check that op-amp are in the correct orientation, and not flipped around 180 degrees.

Getting effect when toggle switch is set to Engage, but it doesn't sound as expected.

Check that the op amp is in the correct orientation and not flipped around 180 degrees. Check that the resistors are in the correct place and didn't get swapped with a different value. Pay attention to the orientation of Polarized components (Diodes and Electrolytic Capacitors).

Still stuck? Please reach out to us with any questions you have! We're here to help. Please email us at: diy@coppersoundpedals.com

