

# MONKEY BARS



## PRODUCT SPEC SHEET

### ABOUT THE MONKEY BARS

Made from 1"x 0.65" wall hollow plain carbon steel tubing, with 11 gauge plain carbon steel mounting plates.

\*Supports 250 lbs. per handle when properly attached to adequate backing.

Fastener holes are 3/8" outside diameter (OD).

\*\*\*

Drawings are representations only and not to scale.

PRODUCT SPECIFICATIONS		
LOAD CAPACITY*	250 Pounds	
MONKEY BAR WEIGHT(LBS)	A: 1.35	B: 1.35
DEPTH	A: 4"	B: 4"
HEIGHT	A: 1.35"	B: 3.5"
WIDTH	A: 17.5"	B: 25.5"

A

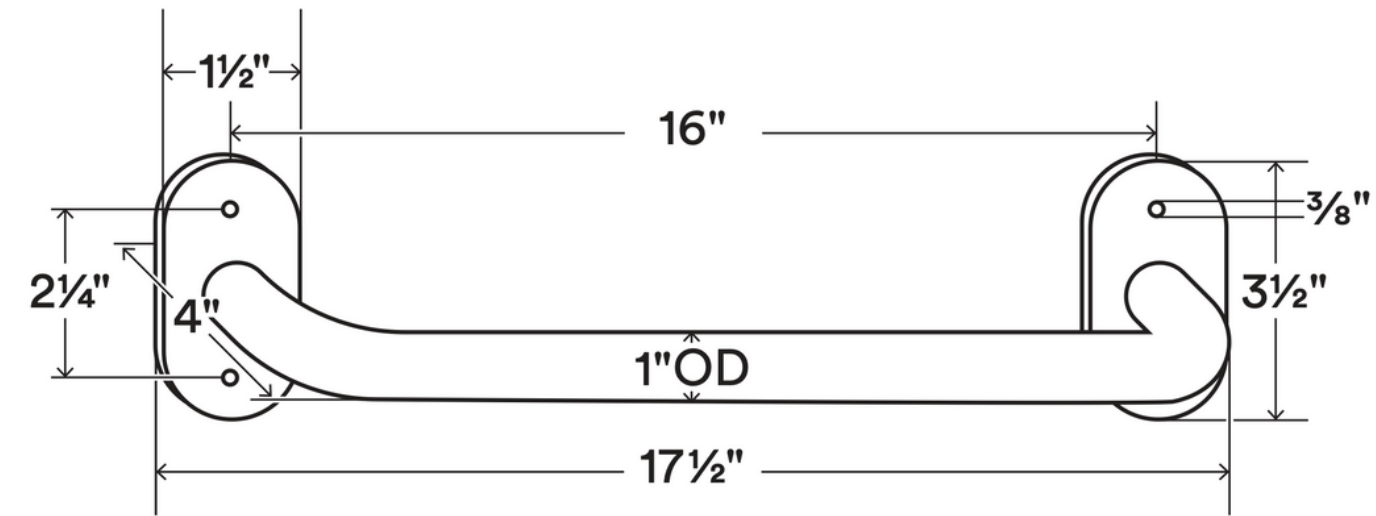

B

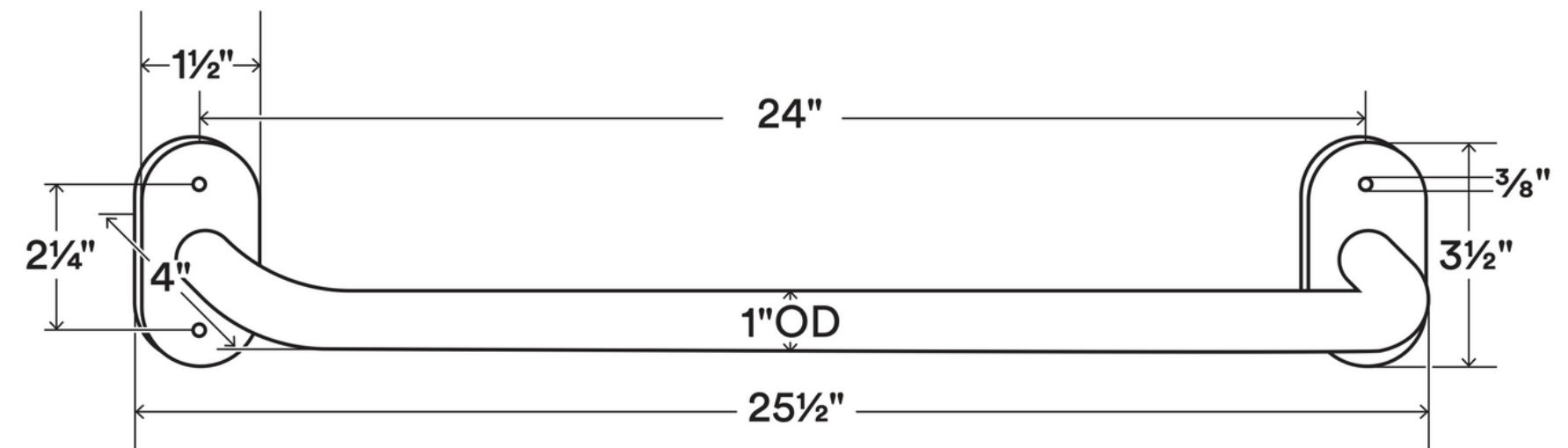

**WARNING** – All monkey bars must be installed into studs, joists, or blocking. Failure to do so may result in saggy product, falling objects, or even injury. Please reference the Installation Guide for more information.