



**POPULAS**  
furniture by AD·AS

**SPECIAL NEEDS**  
**COMPUTERS**   
**1-877-724-4922**

## VOX™ SERIES

### Motorized, height adjustable table

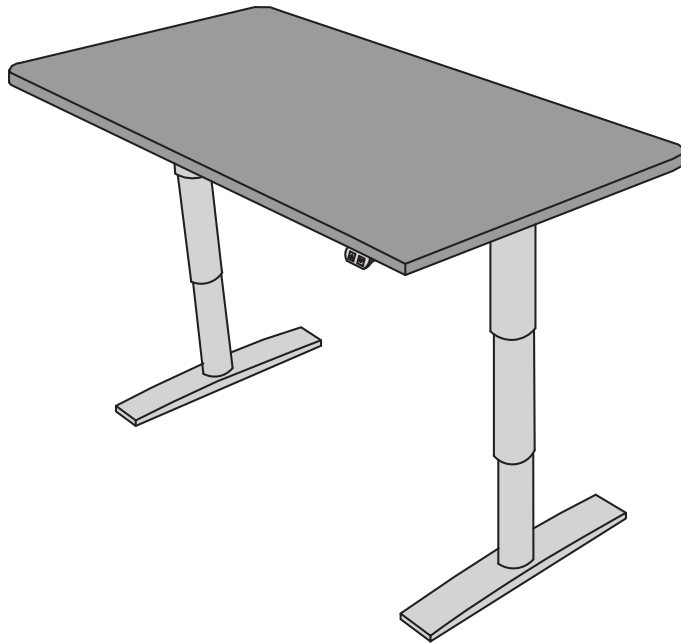

Computer workstation features smooth, quiet motorized adjustment with extra-low and extra-high height range. The Vox™ series is designed without a cross brace enabling maximum knee space.

**FEATURES:**

- Single surface table with vertical height adjustment for individual positioning or multiple user environments
- Push-button motorized adjustment throughout the specified range
- Push-button controls can be mounted on either side of table
- Durable laminate top or real wood veneer

**TECHNICAL DATA:**

- See chart for standard dimensions
- Custom workstation top sizes and finishes available
- Vertical adjustment range 24" - 50"
- System operates on standard 110V, electric motor UL listed
- Extruded aluminum telescoping legs
- Base finish Graphite Silver
- Load capacity 265 lbs

MODEL	DIMENSIONS	ADJUSTMENT RANGE	START/END HEIGHT	LEG SPAN
VX 3624	36" X 24"	26"	24", 50"	27"
VX 3630	36" X 30"	26"	24", 50"	27"
VX 4824	48" X 24"	26"	24", 50"	36"
VX 4830	48" X 30"	26"	24", 50"	36"
VX 6024	60" X 24"	26"	24", 50"	41"
VX 6030	60" X 30"	26"	24", 50"	41"



**POPULAS**  
*furniture by AD·AS*

**VOX SERIES**  
Dimension page

VX 3630 and VX 3624

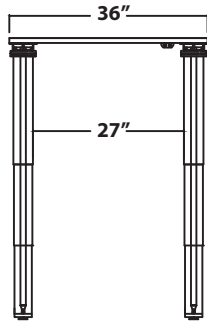

**Front View**

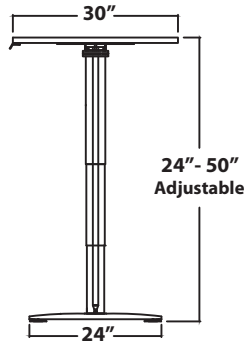

**Side View**

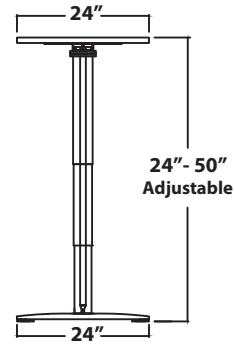

**Side View**

VX 4830 and VX 4824

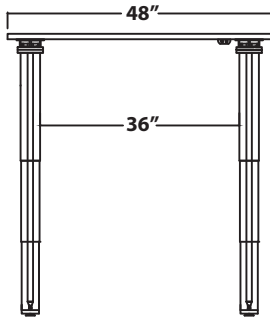

**Front View**

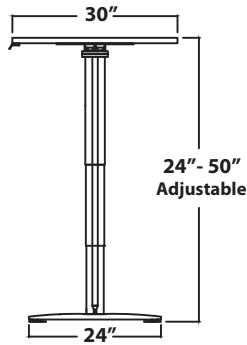

**Side View**

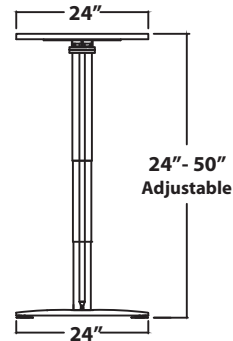

**Side View**

VX 6030 and VX 6024

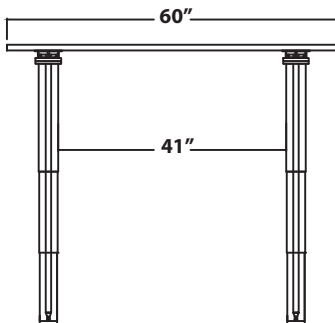

**Front View**

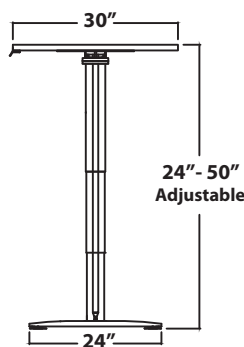

**Side View**

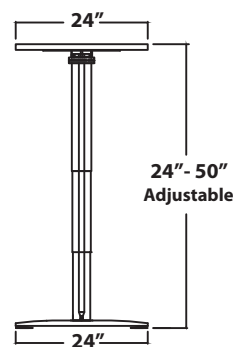

**Side View**