



POPULAS
furniture by AD·AS

SPECIAL NEEDS
COMPUTERS 
1-877-724-4922

VOX™ CORNER OFFICE
Electric, bi-level height adjustable workstation

Computer workstation features smooth, quiet motorized adjustment with extra-low and extra-high height range. The Vox™ series is designed without a cross brace enabling maximum knee space.

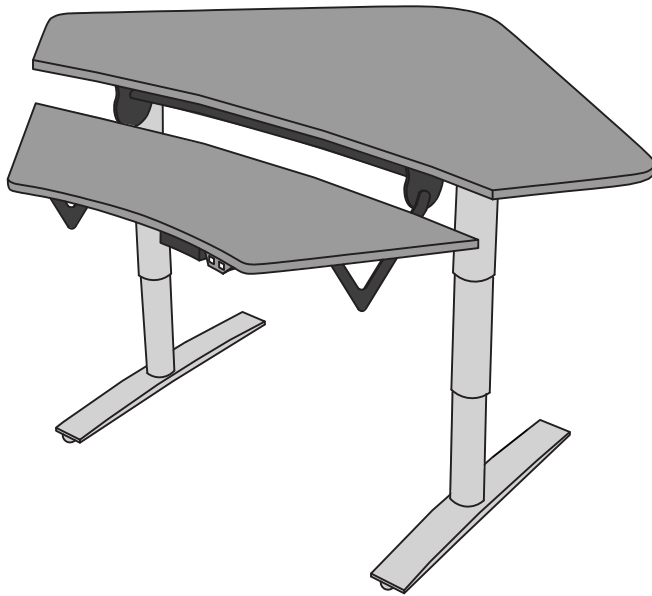

FEATURES:

- Dual surface workstation with vertical height adjustment provides adjustability for individual positioning or multiple user environments
- Push-button powered rear surface, Lift-N-Lock front surface
- Push-button controls mount on either side
- Convenient corner design to maximize usable space
- Infinite height adjustment throughout the specified range
- Durable laminate top

TECHNICAL DATA:

- Table dimensions: 59" x 42"
- Surface dimensions: 38" x 10", 59" x 31", front edge 17"
- Powered rear surface vertical adjustment range 24" - 50"
- Front surface adjustment range 20" - 57" (4" below, 7" above rear surface), with 15° +/- tilt
- Front surface load 50lbs
- Rear surface load 265 lbs
- System operates on standard 110V
- Extruded aluminum telescoping legs
- Base finish Graphite Silver

MODEL	FRONT/REAR DIMENSIONS	OVERALL DIMENSION	ADJUSTMENT RANGE	REAR START/END HEIGHT	LEG SPAN
VX 4230 CBL	38" X 10" 59" X 31"	59" X 42"	26"	24", 50"	29"

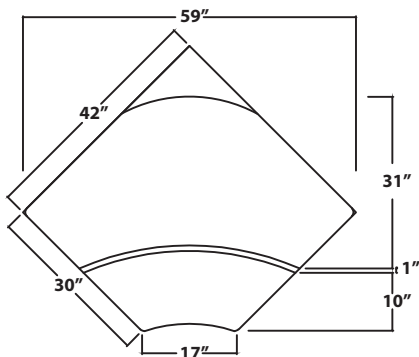

Top View

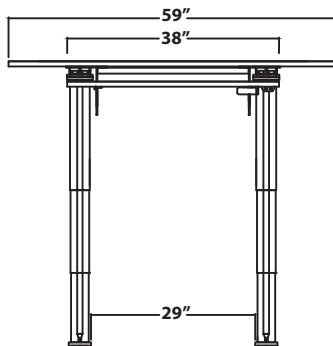

Front View

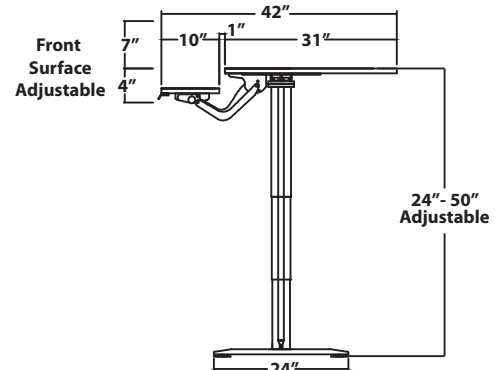

Side View