



VIEWPLUS

**VP Rogue User Manual
Revision: 2022 January**

SPECIAL NEEDS
COMPUTERS 
1-877-724-4922

Table of Contents

- I. Introduction3
 - A. Preface3
 - B. Compliance Statements.....4
 - C. Safety Instructions6
- II. General Information7
 - A. Embosser specifications.....7
 - B. The Rogue technology8
 - C. System compatibility8
- III. Printer Setup9
 - A. VP Rogue Trac - Unpacking.....9
 - B. VP Rogue Sheet - Unpacking.....10
 - C. VP Rogue Sheet - Paper Tray Attachment.....12
 - D. Cable Attachment13
 - E. Software Installation14
- IV. Printer Properties17
 - A. Introduction17
 - B. Printer Properties18
 - Device Settings tab18
 - Service tab23
 - C. Printing Preferences28
 - Layout tab29
 - Paper/Media tab.....30
 - Tiger tab33
- V. Operator Panel36
 - A. Button functions36
 - B. Operator Panel Menu37
 - C. Machine status and alerts39
- VI. VP Rogue Sheet - Paper Handling.....40
 - A. Paper Loading40
 - B. Paper Feed Adjustment41
 - C. Paper Jams42

VII. VP Rogue Trac - Paper Handling	43
A. Paper Loading	43
B. Paper Jams	43
VIII. Braille, Translation and Printing	45
A. ViewPlus Tiger Software Suite	45
B. Fonts	45
C. Math and Braille	46
D. Printing	46
IX. Software Packages	47
A. Software Packages	47
X. Training, Warranty, Maintenance and Support	48
A. Training	48
B. Maintenance	48
C. Support	48
D. Warranty	48

I. Introduction

A. Preface

VP Rogue Embosser Owner's Manual

Congratulations on purchasing a VP Rogue Braille and tactile graphics embosser! Whether you have a VP Rogue Sheet or VP Rogue Trac embosser, this manual will introduce you to basic information regarding your new embosser.

The Rogue embosser is considered the best of the best for tactile graphics - it combines multiple key functions from other ViewPlus products and rolls them into one! The Rogue utilizes 12 impact devices to emboss Braille and high-resolution tactile graphics with variable dot heights. It also produces fast single sided tactile graphics with hand-catching Tiger dots for improved readability of complex images. Whether using the Rogue Trac or Rogue Sheet, the Rogue offers the ability to print on paper of up to 12-inch width. And the sound absorbing roller die makes Powered by Tiger embossers much quieter than other Braille printers.

ViewPlus embossers use standard Windows printer drivers to mix text and graphics in mainstream Windows software like MS Office Word and Excel. Use the computer to adjust settings and preferences. Print documents exactly how they appear on the screen. In addition the Rogue embosser output can be tuned to match the layout of a color output from a third party printer to provide both ink and braille text and graphics together.

ViewPlus embossers are compatible to third party products like Duxbury and RTFC braille translation software and they can be used to print Braille from Braille note takers.

Use the Tiger Software Suite (TSS) to take braille translation and tactile graphics to a new level. The Tiger Software Suite provides a Microsoft Office Add-in that includes advanced tools for translation and embossing. Tiger Designer enables basic editing of documents for quick drawing and braille needs, and TSS 8 now offers the ability to use a pattern fill library for automatic replacement of colors with tactile pattern fill. Translator serves as a basic translation tool for almost any Windows software – including PowerPoint and Corel Draw.

Keep up to date by checking the ViewPlus Technologies, Inc. webpage at:

<http://www.ViewPlus.com>

VP Rogue Product Number: VPTT2412-01 (Trac)
VP Rogue Product Number: VPTT2412-02 (Sheet)

USER MANUAL

B. Compliance Statements

FCC Compliance Statement (USA)

This equipment has been tested and found to comply with the limits for a Class A digital device, pursuant to Part 15 of the FCC Rules. Operation is subject to the following two conditions: (1) this device may not cause harmful interference, and (2) this device must accept any interference received, including interference that may cause undesired operation. If this equipment does cause harmful interference to radio or television reception, which can be determined by turning the equipment off and on, the user is encouraged to try to correct the interference by one or more of the following measures:

- Reorient or relocate the receiving antenna.
- Increase the separation between the equipment and receiver.
- Connect the equipment to an outlet on a circuit different from that to which the receiver is connected.
- Consult the dealer or an experienced radio/TV technician for help.

FCC Warning: Changes or modifications not expressly approved by the party responsible for compliance could void the user's authority to operate the equipment.

Note the following:

- The use of a non-shielded interface cable with the referenced device is prohibited.
- The length of the power cord must be 3 meters (10 feet) or less.

This unit is also intended for connection to IT distribution systems.

Compliance Statement (Canada)

This digital apparatus is in conformity with standard ICES-003 of Canada.
Cet appareil numérique est conforme à la norme NMB-003 du Canada.

Compliance Statement (Germany)

Bescheinigung des Herstellers/Importeurs: Hiermit wird bescheinigt, dass der Drucker der Maschinenlärminformationsverordnung 3. GSGV, 18.01.1991 entspricht: Der höchste Schalldruckpegel beträgt 70 dB(A) oder weniger gemäß EN27779-1991.

Compliance Statement (Europe)

Warning: This product meets the interference requirements of EN 55032. In a domestic environment, this product may cause radio interference in which case, the user may be required to take adequate measures.

Compliance Statement (Korea)

This apparatus complies with CISPR32 requirements.

International Compliance



EN 55032:2012 Class B

EN 55024:2010

EN 61000-3-2:2014

EN 61000-3-3:2013

EN 55024:2010

EN 55024:2010

EN 55024:2010

EN 55024:2010

EN 55024:2010

EN 55024:2010

EN 55024:2010

Emissions series

Immunity characteristics

Power line harmonics

Power line flicker

Electrostatic discharge

Radiated immunity

Electrical fast transient/burst

Surge

Conducted immunity

Magnetic Field Immunity

Input voltage interruptions/DIPS

C. Safety Instructions

Read all safety instructions before using the embossing printer. In addition, follow all warnings and instructions marked on the embossing printer itself, including this symbol:



Which means: "Evaluation for apparatus only based on altitude not exceeding 2000 m, therefore it's the only operating condition applied for the equipment. There may be some potential safety hazard if the equipment is used at altitude above 2000 m."

Follow these safety instructions when using the embossing printer:

- Do not use the embossing printer at altitude above 2000m.
- Do not place embossing printer on an unstable surface.
- Do not place embossing printer near a radiator or heat source.
- Do not block or cover slots and openings in the embossing embosser's cabinet; do not insert objects through slots.
- Use only the type of power source indicated on embossing embosser's label.
- Connect all equipment to properly grounded electrical outlets.
- Do not use frayed or damaged power cord.
- The use of an extension cord with the embossing printer is not recommended.
- Unplug embosser before cleaning it; always clean it with a piece of damp cloth only.
- Do not spill liquid into embossing printer.
- Except as specifically explained in the user's manual, do not attempt to service the embosser by yourself.
- Only adjust those controls that are covered by the operating instructions.
- Detach the embosser from power source and refer to qualified service personnel under the following conditions:
 - If the power cord or plug is damaged.
 - If liquid has entered the embosser.
 - If the embosser has been dropped or the cabinet is damaged.
 - If the embosser does not operate properly or exhibits a distinct change in performance.

II. General Information

A. Embosser specifications

	VP Rogue Embosser
Print Speed	Up to 120 CPS, single sided
Tactile Resolution	20 or 100 DPI
Embossed Dot Density	Up to 20 DPI
Braille Dot Spacing	Selectable from 5 international Standards
Tactile Graphic Dot Heights	7 steps for color representation
Braille Dot Heights	Adjustable in 3 heights
Paper Feed Method	Single sheets stack sheet feeder from the top (Rogue Sheet) Tractor feed from the back (Rogue Trac)
Paper Width	7 to 12 inches (176 to 305mm)
Paper Weight	Adjustable for different media from 33 lb, or 90 g/m ² (Copy paper) to 120 lb, or 200 g/m ² (heavy Braille paper)
Power Supply	Voltage: 100 to 240 VAR (± 10%) Frequency: 50/60 Hz (± 3%)
Power Consumption	Standby: 20 W Average Embossing: <150 W Heavy Embossing: <200 W
Fuse	5 A, 250 V slow blow long time lag 5x20mm
Embosser Dimensions	
Width	21.9" (557 mm)
Depth	10.8" (275 mm)
Height	6.2" (158 mm), 16.3" (415 mm) incl. stack sheet feeder
Weight	19.8 lbs (9 kg)
Connectivity	USB and Ethernet
Operating Conditions	
Operating Temperature	59 to 95 °F (15 to 35 °C)
Storage Temperature	-4 to 158 °F (-40 to 70 °C)
Relative Humidity	20 to 80% RH (non-condensing)
Altitude	Below 2000m
Acoustics	<= 70 dBA per ISO 7779

B. The Rogue technology

The VP Rogue combines both Tiger technology and TigerPlus technology into one machine. Users can now create new content with 100 DPI resolution along with 20 DPI dot spacing for the best of the best in producing high-quality tactile graphics, or reuse existing content created for Tiger embossers and print data of any other ViewPlus embosser.

Tactile graphics can be printed with a variable dot placement in draft, standard, or best mode; or it can print tactile graphics with a fixed grid placement of 20 DPI to create smooth shapes and diagonal lines. When combined with Tiger Software Suite (TSS8), new, enhanced, and automated texture fill patterns can now be created to represent color.

The setting of the Braille dot spacing to one of the five following international braille standards:

- (1) Marburg Medium (German), equivalent to traditional Tiger Braille system
- (2) American Library of Congress
- (3) American National Library of the Blind
- (4) Japanese Standard (Micro Braille)
- (5) Korean Standard

Additional to these braille standards, Jumbo Braille can be created when using Tiger Software Suite (TSS) in MS Office Word, or Excel. Or, when printing to a note taker in legacy mode, Jumbo Braille can be selected in Braille spacing options of Device Settings (see section IV.B.).

C. System compatibility

The Windows driver for the Rogue is compatible with operating systems from Windows 7 to current Windows versions, both 32- and 64-bit systems. The Windows driver allows users to print to the Rogue embosser from virtually any program under the Windows operating system. See more about installation of Windows printer driver in section III.E.

A Mac OS 10.9 printer driver is also available for the ViewPlus Rogue embosser. The printer driver installation allows to use Braille fonts for uncontracted Braille translation as described in section VIII.B. regarding Windows system fonts that install with the printer driver.

III. Printer Setup

A. VP Rogue Trac - Unpacking

- Remove the embosser and all its accessories from its packaging. In addition to the embosser, the package should include power cord, USB cable, Warranty Card, Braille Setup Instructions and a USB flash drive containing printer driver, user manual and other documentation.
- Inspect the ViewPlus embosser and its packaging for any damage. If noticeable damage occurred, please report to your ViewPlus product supplier immediately.
- **Save the packing material and box.** The packing material must be used to ship the ViewPlus embosser for warranty maintenance service.
- Remove the shipping lockout bolt by opening the top lid of the embosser and taking out the long shipping bolt as indicated in the picture below. Store the shipping bolt behind the plastic clamps against the rightside frame as indicated in second picture below.

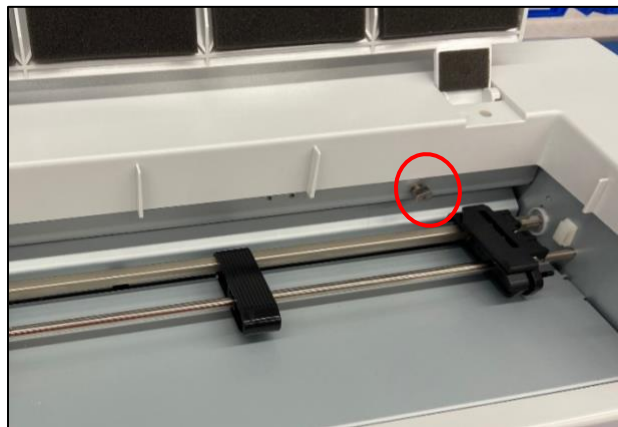

Shows the shipping bolt for carriage lock during shipping

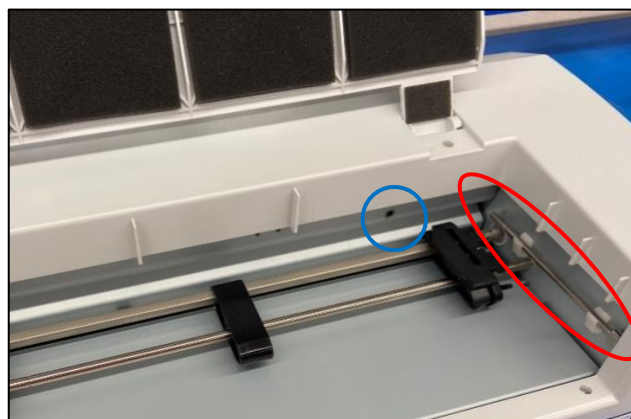

Shows the shipping bolt removed (blue) and how to store (red)

- **Before packing up the embosser again for shipping, make sure to re-install the shipping bolt for carriage lockout properly!** Please make sure, the shipping bolt is installed properly, and the

embosser is secured with the specific foam end caps during shipping, otherwise your warranty will be voided.

- Also, if any damage occurred during shipping, most shipping companies require the box and the packing material in order to settle the insurance claim.
- For further embosser setup also follow the Instructions included with your other materials.

B. VP Rogue Sheet - Unpacking

- Remove the embosser and all its accessories from its packaging. In addition to the embosser, the package should include the paper tray, paper feed adjustment knob, power cord, USB cable, Braille Setup Instructions and a USB flash drive containing printer driver, user manual and other documentation.
- Inspect the ViewPlus embosser and its packaging for any damage. If noticeable damage occurred, please report to your ViewPlus product supplier immediately.
- **Save the packing material and box.** The packing material must be re-used to ship the ViewPlus embosser for warranty maintenance service, or for any other reason of transport.
- First push in the paper feed adjustment knob, which is easily accessible after opening the top lid of the embosser.



Shows the Paper Feed Adjustment Knob correctly in place

- Remove shipping lockout rod, which is accessible after opening the top lid of the embosser. When looking at the embosser from the back, you will find the head of the metal rod protruding through an opening in the sheet metal near the right side as indicated in the picture below. The head can be grabbed to unscrew the rod. Unscrew and take out the rod completely.



*Shows shipping lockout rod to be removed
Also note the Paper Feed Adjustment Knob is in place*

- The rod should be stored laying it flat on the surface behind the angled up sheet metal part that will receive the stack sheet feeder. "Behind" this part when looking at the embosser from front. The next picture shows the stored shipping lock rod with plastic clamps that will receive the rod to keep it in place. Optionally, a piece of adhesive tape could be used to hold the rod in place when the embosser is moved.



Shows storage area of shipping lockout rod

- **Before packing up the embosser again for shipping, make sure to re-install the shipping lockout properly!** Please make sure, the shipping lockout is installed properly, and the embosser is secured with the specific foam end caps during shipping, otherwise your warranty will be voided.
- Also, if any damage occurred during shipping, most shipping companies require the box and the packing material in order to settle the insurance claim.
- For further embosser setup please follow the Instructions included with your other materials.

C. VP Rogue Sheet - Paper Tray Attachment

The Rogue Sheet paper tray needs to be assembled as indicated in the picture below. The two plastic extensions, that are included with the embosser packaging, need to be inserted into slots along the top edge of the stack sheet feeder tray.

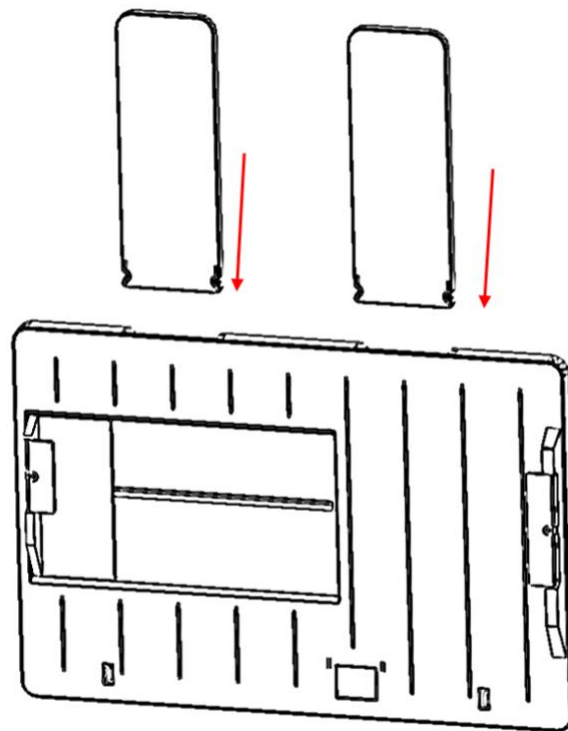

Assembly of paper tray

The assembled paper tray shows a little cork area. To find the correct orientation before sliding the paper tray into position on Rogue Sheet, hold the tray piece with the cork area at the down side, pointing towards the front of the embosser (operator panel). Then find the guides within the open slot

at the top of the embosser with closed lid, and fit the paper tray piece inside. Push the paper tray down until it snaps into place.

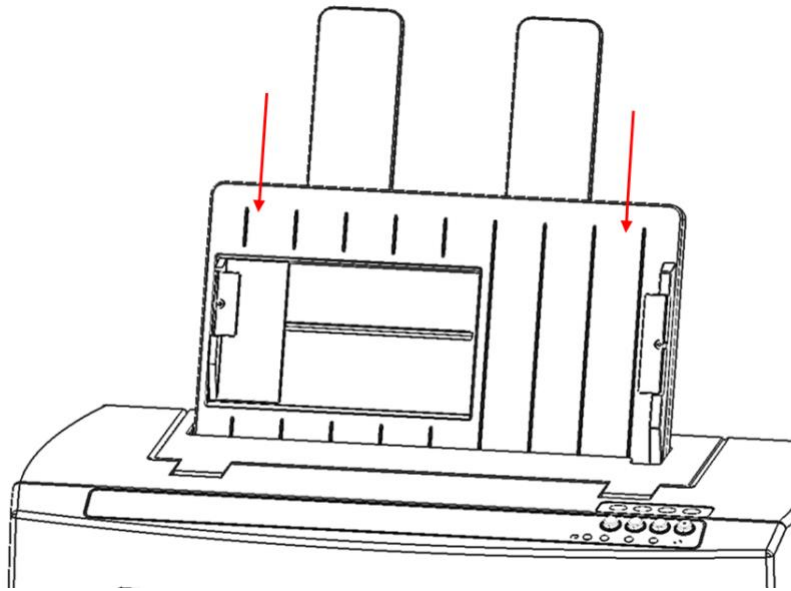

Shows Paper tray installment

D. Cable Attachment

Power connection

On the back of the embosser you find a power module with a power socket, on/off switch, and a compartment holding one fuse. A sticker above the power module indicates what specific fuse is required for the embosser. If the embosser will not power on, it might be necessary to replace the fuse.



Shows the power module in the back of the embosser

Insert the power cable plug into the VP Rogue power connector and the other end of the power cable into a grounded outlet or a surge protector (recommended).

Turn the embosser on by pressing the power switch to the 'I' position. When facing the embosser from the front, the 'I' position of the switch is towards the left side.

Data cable

A USB printer cable was included in your box. To use it, attach the square end of the USB data cable into the matching port of the embosser. The USB connection is the center one of three sockets located on the right lower side of the machine when facing the front. Insert the rectangular end of the USB data cable into host computer USB port.

You may also use a LAN cable to connect the embosser to your network. The embosser is not shipped with a LAN cable. To use this connection method, attach one end of a LAN cable to the connection port furthest towards the back of the machine when facing the front, and attach the other end to a network data port.

Audio output jack

The third connector socket, furthest towards the front of the three sockets on the lower side of the machine, is an audio output jack. Plug in your powered speaker to pick up any audio message, like status messages, on-board menu items and commands, and error messages here. The speaker must be powered since there is no on-board audio amplifier.

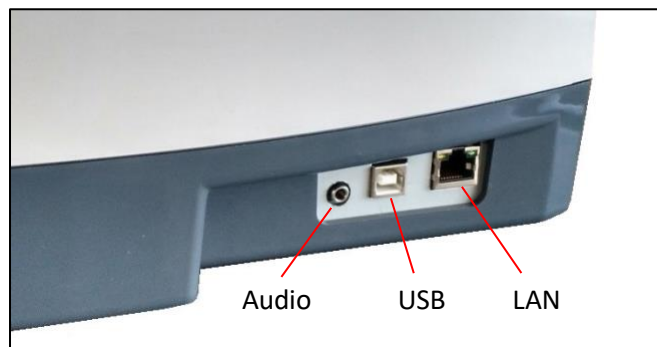

Shows three sockets on the right side of the embosser

E. Software Installation

Included with your VP Rogue embosser is a USB flash drive, that contains the Windows printer driver as well as the ViewPlus Tiger Software Suite (TSS).

NOTE: DO NOT CONNECT YOUR ROGUE EMOSSER TO THE COMPUTER DURING INSTALLATION OF THE WINDOWS PRINTER DRIVER OR TURN IT OFF WHEN ALREADY CONNECTED.

Run the driver setup from the USB or download the appropriate current driver from the ViewPlus website, www.viewplus.com.

Follow the instructions from the advanced installer program where the first screen will ask to pick your preferred language pack for the driver installation.



Shows choices of printer driver user interface languages

Before installation really starts, you will also be asked to accept the terms of ViewPlus Technologies license agreement. Installation will not finish successfully if you don't agree.

If network installation of the Rogue embosser is desired, please pause at the screen, asking whether to run the network installation utility and DO NOT click 'Finish' until the printer is connected and switched on.

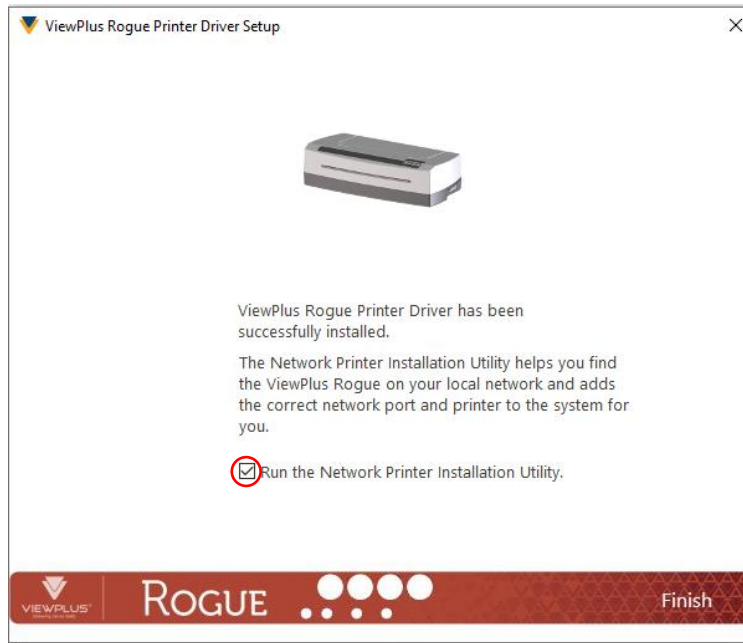

Shows printer driver network installation screen

If no network installation is desired, finish the driver installation, if network installation is desired DO NOT click finish on the last screen of the driver installation. In both cases, connect the VP Rogue to the computer via USB now, and turn it on. The system should automatically detect the embosser and add it to the system control panel under 'Devices and Printers'.

It is possible that Windows will not detect the printer on the first try. In this case, just unplug and plug it back in to the same USB port of your computer. If Windows is still not detecting the embosser try another USB port.

For network installation, connect a LAN local network cable to the VP Rogue embosser after the printer has been locally detected via USB. Before clicking 'Finish' now, make sure the check box 'Run the Network Printer Installation Utility' is checked on the last printer driver installation screen. The network connection for the device should now install automatically.

The Network Printer Installation Utility can also be started outside the printer driver installation from the Windows start menu, under ViewPlus program folder.

After your VP Rogue printer driver installed successfully, you may also install the ViewPlus Tiger Software Suite from the included USB flash drive. For installation, please follow the instructions from the setup program. For use of the Tiger Software Suite (TSS) please refer to the TSS user manual.

Removal of Printer Driver

If you wish to remove the VP Rogue printer driver application from your computer, you can either run the printer driver setup program again, which will give you the option to remove the driver, or use Windows

uninstall option under system control panel 'Programs and Features', or Windows system settings 'Apps & features' respectively.

Removal of Printer Device

Deleting the Rogue device appearance under system control panel 'Devices and Printers', or removing the device under Windows system settings 'Printers & scanner' respectively, will not remove the printer driver installation from your computer, but just the instance of the device assigned to a specific port.

Sometimes, Windows will automatically add instances of the same device under system control 'Devices and Printers' and all of the sudden, you have Copy 1 or further available from your printer. If this is not desired, and you have trouble assigning your print jobs to the correct printer device name, please go ahead, unplug the Rogue and remove all Rogue printer devices under system control panel 'Devices and Printers'. Now plug the Rogue back in, and Windows should automatically add one instance of the printer again, which will then be assigned to the correct port, too.

IV. Printer Properties

A. Introduction

The ViewPlus printer driver uses a standard Windows printer driver interface to provide user access to setting options on the ViewPlus embosser from a local or networked computer. The printer properties are accessible through the Windows system control panel 'Devices and Printers'. Select the VP Rogue in the list of printers and get to the printer properties through the context menu. The printer properties contain general device settings such as for connectivity, sharing, and security, but also ViewPlus specific settings for legacy mode operation and service procedures on the ViewPlus embosser. Note that these options are only activated when your VP Rogue is currently connected to your computer and switched on.

Always click on the 'Apply' button to have changes submitted to the device.

B. Printer Properties

Device Settings tab

The device settings are properties that are stored within the internal memory of the printer. Therefore, the printer needs to be connected and turned on. To activate any changes, always click the 'Apply' button when done with settings. The printer will beep once to confirm the receiving of the changed settings.

The settings you find under 'Legacy Settings' will control the embosser's output when printing to the Rogue from programs that do not use the Windows printer driver, including some Braille programs and note taker devices. Some of these settings are also available through the embosser operator panel controls to make them accessible without having to have a Windows computer connected. See section V.B. for further explanation on operator panel menu.

See a picture of the VP Rogue printer properties Device Settings tab below. Use the following descriptions to make your selections.

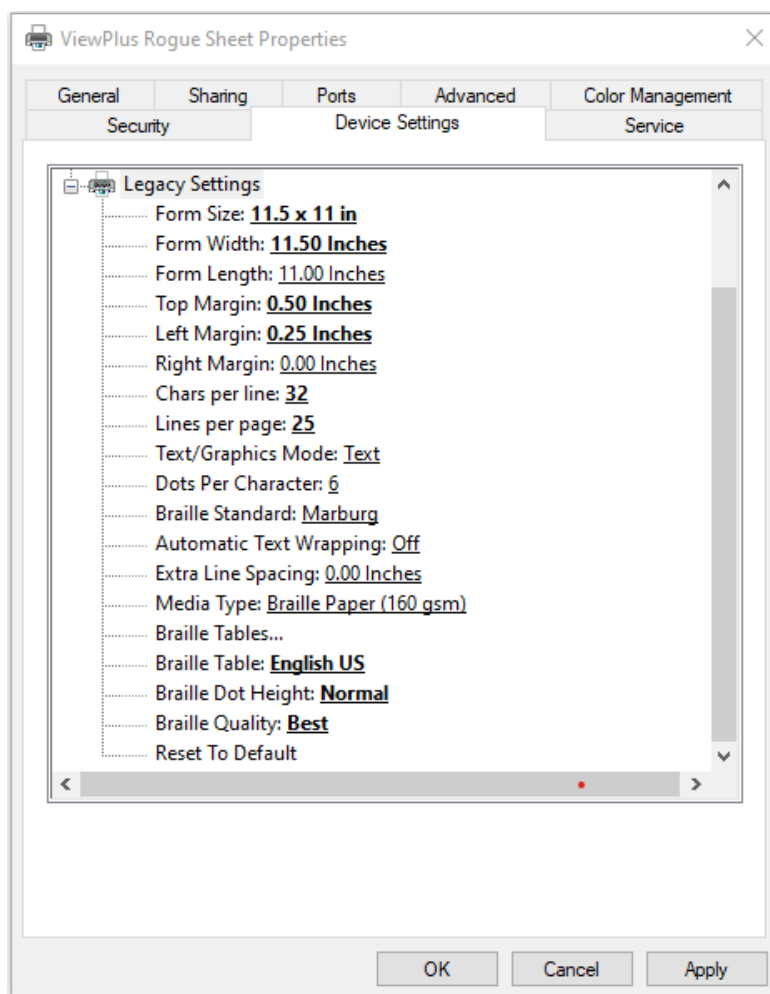

Shows Device Settings Tab

- **Form To Tray Assignment**

The first section of the Device Settings tab shows the Rogue's 'tray assignment'. Feel free to ignore this as it is a Windows default item that can't be hidden, but it does not have any relevance for your printing.

- **Legacy Settings**

Form Size: Select a standard page size, or select Custom to set the page size manually.

Form Width: This field shows the page width. For standard page sizes, this field is informational only. If the Form Size is set to Custom, this field is editable.

Form Length: This field shows the page length. For standard page sizes, this field is informational only. If the Form Size is set to Custom, this field is editable.

Top Margin: Set the top margin to be used when printing in legacy mode.

NOTE: IF YOU ARE PRINTING FROM AN APPLICATION THAT SENDS MARGIN INFORMATION WITH THE PRINT JOB, SET THE TOP MARGIN TO 0.

Left Margin: Set the left margin to be used when printing in legacy mode.

NOTE: IF YOU ARE PRINTING FROM AN APPLICATION THAT SENDS MARGIN INFORMATION WITH THE PRINT JOB, SET THE LEFT MARGIN TO 0.

Right Margin: Set the right margin to be used when printing in legacy mode.

NOTE: WHEN EMBOSsing DOUBLE SIDed, ADJUST THE LEFT AND RIGHT MARGIN SETTINGS ACCORDING TO THE REQUIREMENTS FOR THE FRONT SIDE OF THE PAGE. IF THE LEFT AND RIGHT MARGINS ARE SET DIFFERENTLY, THE MARGINS WILL BE APPLIED AS BINDING MARGINS, MEANING THEY WILL BE MIRROREd TO THE BACK SIDE OF THE PAGE WITH THE RESULT THAT THE SAME AMOUNT OF MARGIN IS APPLIED TO THE SAME EDGE OF THE PAPER ON BOTH SIDES.

Chars per line: Specify characters per line for page layout on embosser output. The maximum number of characters per line that will be taken into account for page layout, is the number of characters that physically fit given form width reduced by left and right margin.

Lines per page: Specify lines per page for page layout on embosser output. The maximum number of lines per page that will be taken into account for page layout, is the number of lines that physically fit given page length reduced by top margin.

Text/Graphics Mode: Select Text mode if your legacy document contains text. If the document is a graphic, select Graphics mode to remove the space between Braille lines so that dots may be printed in an even grid.

Dots Per Character: Select 6 or 8 dots per character.

Braille Standard: Select a Standard for Braille dot spacing. The dropdown list contains 'Marburg', 'American Library of Congress', 'American National Library of the Blind', 'Japanese Standard (Microbraille)', 'Korean Standard', and 'Jumbo'. Dot spacing of the embossed output will follow named Standards, or in case of 'Jumbo' it will be the size of 'Marburg' by 1.5.

Automatic Text Wrapping: Select 'On' if lines in the document are longer than will fit on one printed line and you do not wish the lines to be truncated. If the document is formatted correctly for the page size and margins you are using, or if you do not wish to have long lines wrapped to the next line, select 'Off'.

Extra Line Spacing: Set the amount of extra space desired between Braille lines. This setting can only be set in multiples of 0.05 inches and it will be added to the normal single line spacing.

Media Type: The media type setting will define the hammer force that is applied when forming dots in the paper (media). The stronger the media, the higher the punch force needs to be to form readable dots. A list of presets for certain media types is available, but also a number of 'Custom' settings if none of the presets will yield satisfactory embossing results.

To define your own hammering forces for custom media types, you need to use the printer extension program, which is provided from 'Service' tab within Windows printer properties dialog. For further explanation, please find section 'Service tab', and section 'Printer Extension Program' within following pages of this document.

NOTE: THE MEDIA TYPE THAT YOU CHOOSE HERE WILL BE SAVED TO THE EMBOSSER INTERNAL MEMORY, AND WILL REFER TO AS 'Printer Setting' WITHIN MEDIA TYPE SELECTION OF WINDOWS PRINTING PREFERENCES (see section IV.C. below).

Braille Tables...: The VP Rogue has some Braille tables stored on-board, plus a custom Braille table can be stored to the machine additionally. Click 'Properties' to open a dialog as shown in the picture below.

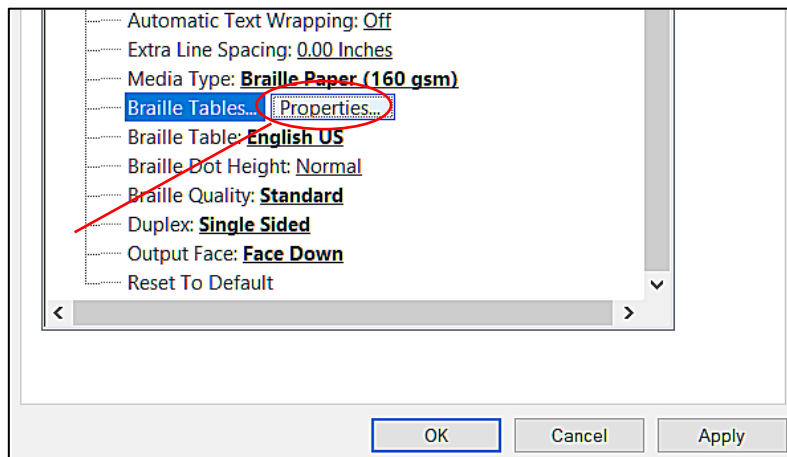

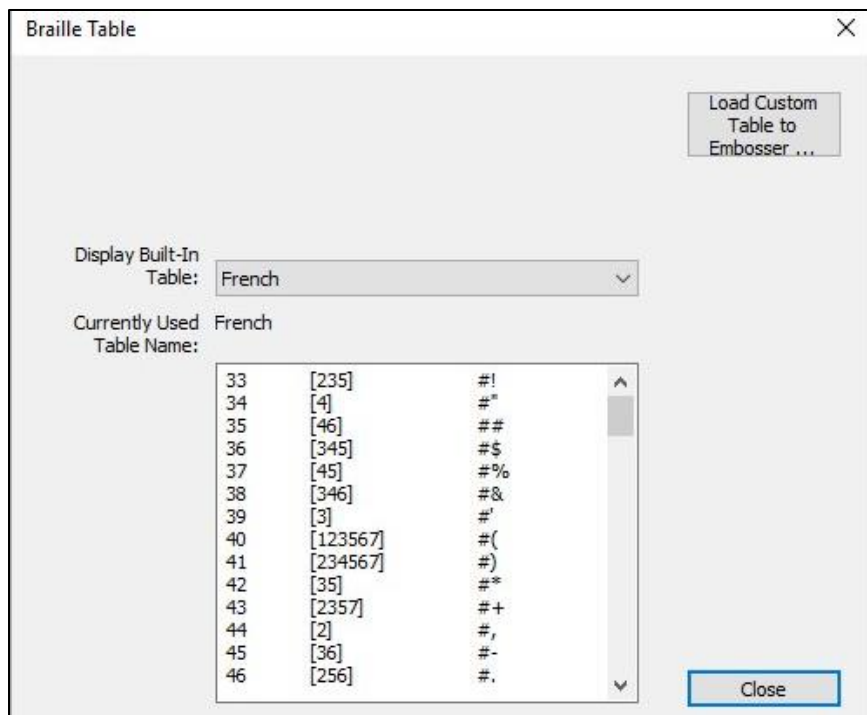

Shows Braille Table Properties in Device Settings

The dialog offers two basic functions. The lower section offers a display for on-board braille tables that the VP Rogue provides, including the current custom table. Choose the Braille table name from the drop down list and you will get the table displayed like illustrated in the picture above.

The second function of this dialog is provided through the button at the upper right. This will open a file browser dialog to choose a custom braille table that will be written to the printer. The braille table that was written to the printer last will be referred to as Custom table and stay on-board as custom table until another file is written to the printer, taking the place of Custom table.

The custom braille table can be chosen as file type *.bct, *.dis, or *.rbt. The file browser dialog will default to the location of the Braille tables being used within Tiger Software Suite. Choose one of those tables, or browse to the location of your own Braille table to be loaded to the embosser.

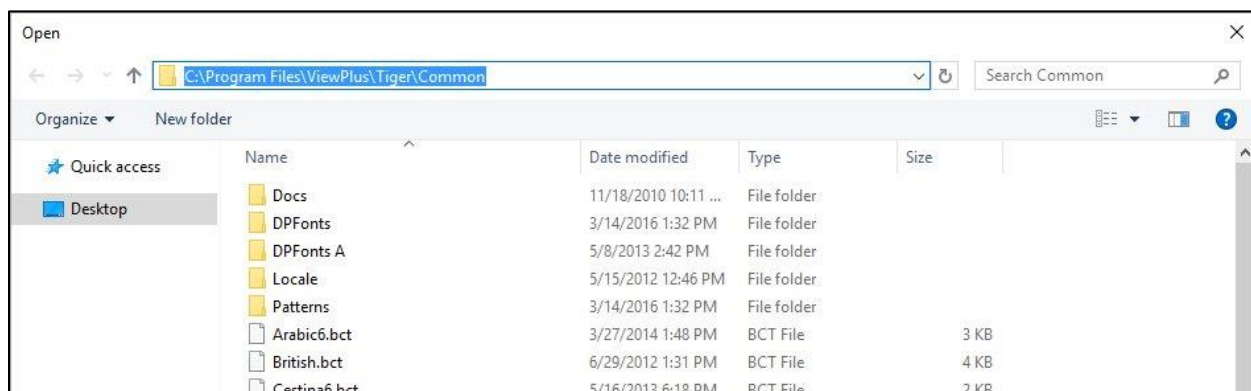

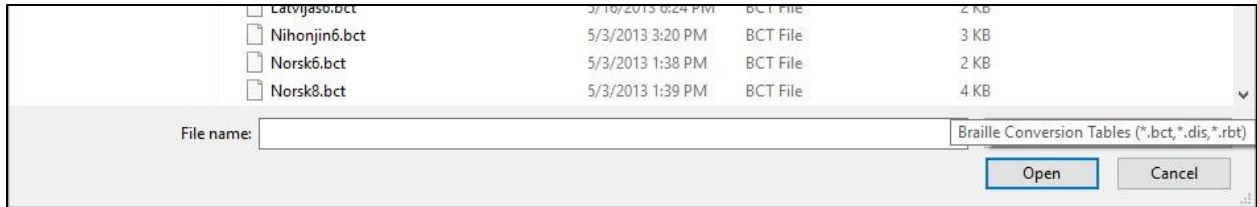

Shows Custom Braille Table file selection

Braille Table: From the dropdown list, select which Braille table to use when printing. If the previously loaded custom table should be used for text to braille conversion, select 'Custom Table' here.

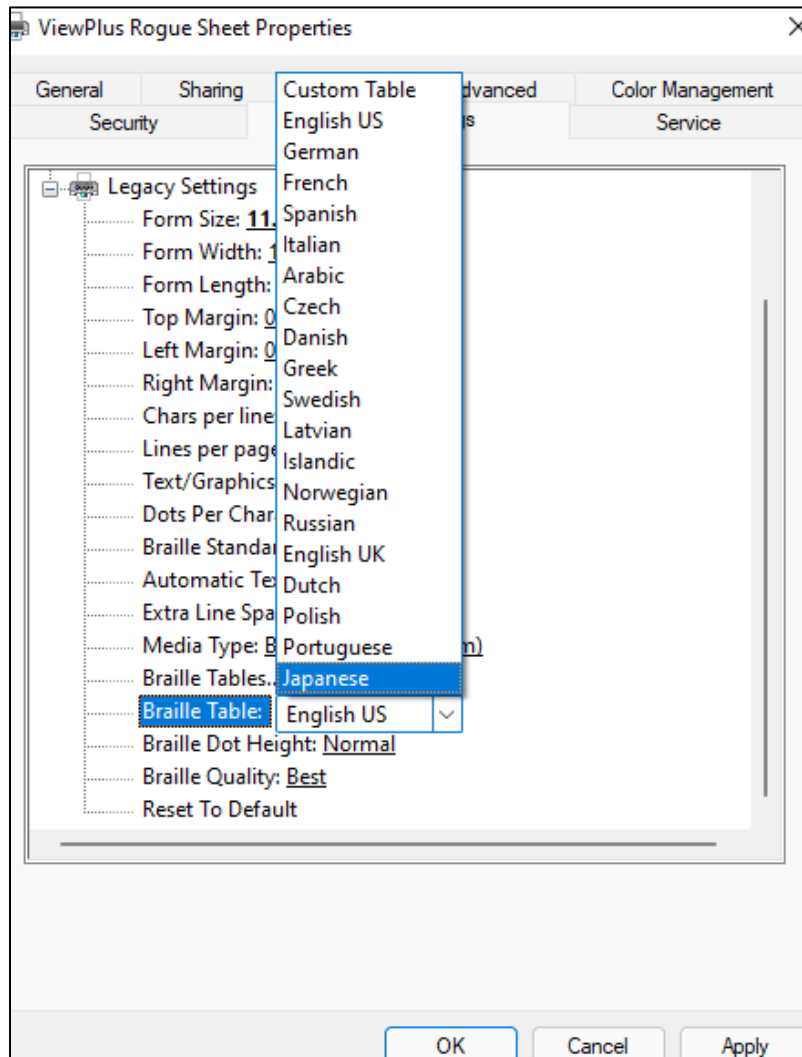

Shows selection of active Braille Table

Braille Dot Height: Select 'Low', 'Normal', or 'High' to control how tall the Braille dots will emboss. This can be adjusted to the preference of the tactile reader.

Braille Quality: The choice of 'Draft', 'Standard', or 'Best' will have influence on accuracy in dots placement and also shape of Braille dots. Please note, that higher quality setting will slow down Braille embossing speed to some extent.

Reset to Default - This will reset all device settings to factory default

Service tab

The Service tab of the printer properties dialog window provides information about the connected ViewPlus Rogue at the bottom left. When contacting ViewPlus Support, please have the driver version, printer serial number, and firmware version available.

Additionally, you find following controls within 'Service' tab:

- **Open Printer Extension...**
A separate program will open to provide extended access to on-board machine settings. Please see further explanation within next document section below.
- **Print Test Page:**
Initiates the printing of an on-board test page from the embosser. Make sure the embosser is properly connected to your computer, and paper is loaded when trying to print a test page.
- **Enable Status Monitoring**
Status messages of the embosser will be displayed and updated permanently as long as the checkbox is checked and the embosser is properly communicating with the computer.

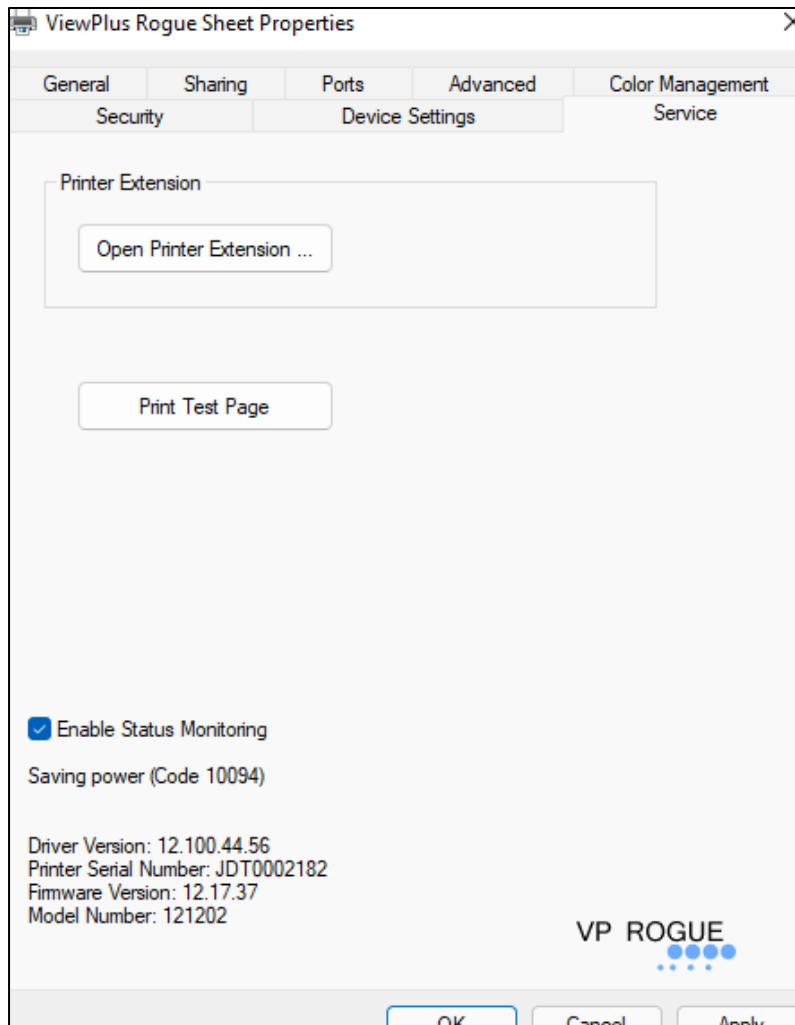

Shows Printer Properties Service Tab

Printer Extension Program

When using the button switch to open the printer extension program, a separate dialog window will open providing three control tabs.

- **Calibration Tab**

If you see problems in quality of Braille output that cannot be overcome with any device settings as explained previously in this document, or with any printing preferences settings as explained in section IV.C. of this document below, then media type calibration, or skew calibration from this printer extension program tab offer additional controls.

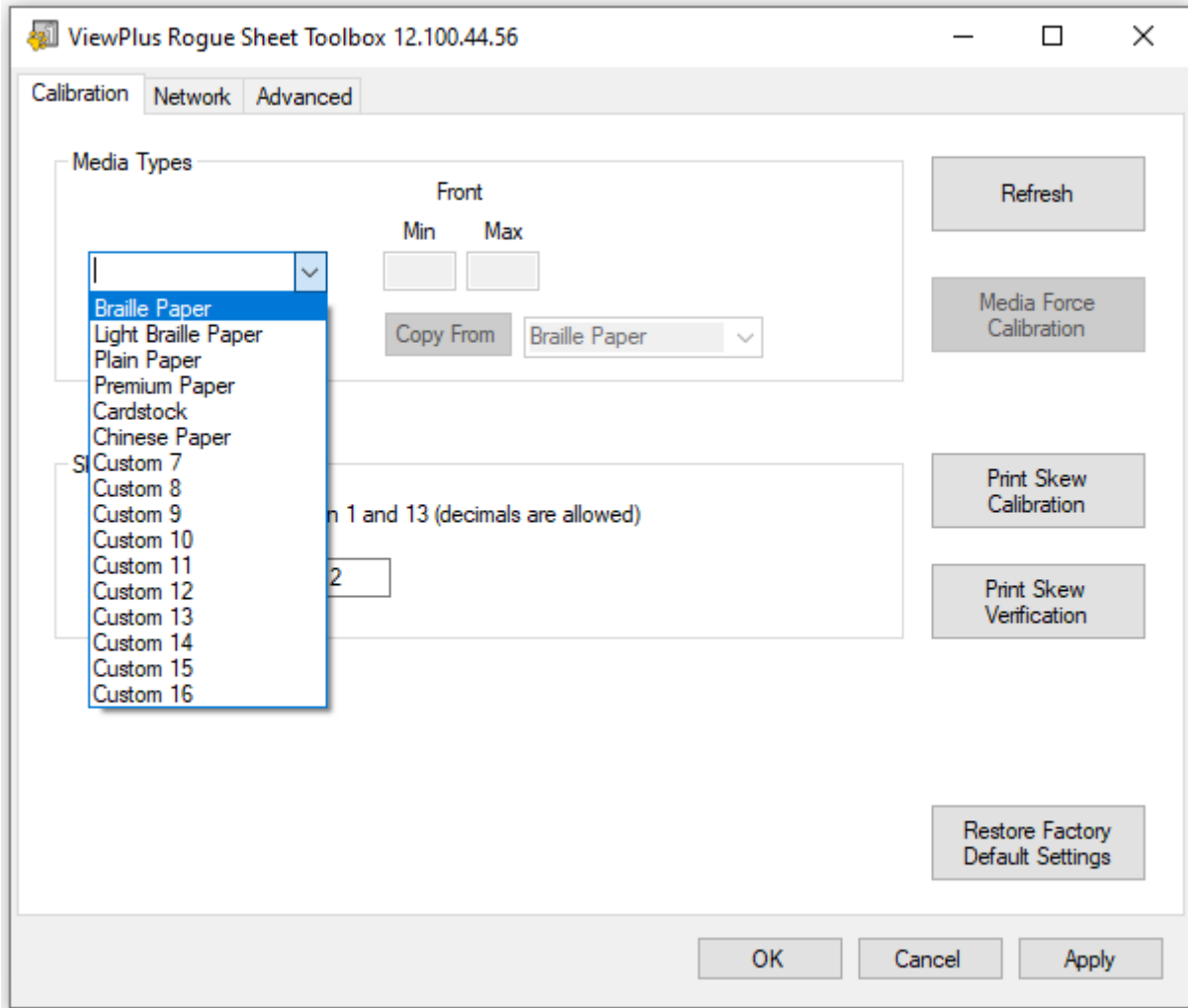

Shows Calibration tab of Printer Extension Program

Media Types: The hammer punch force being applied when embossing is defined by 'Min' and 'Max' settings each for the single-sided embossed dots. Note that the dots come out on the bottom side of the paper as it exits the embosser.

The values for predefined media types can be accessed here, but they are not editable. Additional to preset media types, you have the opportunity to define hammer punch force settings for custom media types here. Therefore select a custom media type from the list and optionally copy the values from one of the predefined media types to start your calibration.

For the calibration of best suited values for your specific print media, select 'Media Force Calibration' to the right. This will open the dialog shown in the following picture.

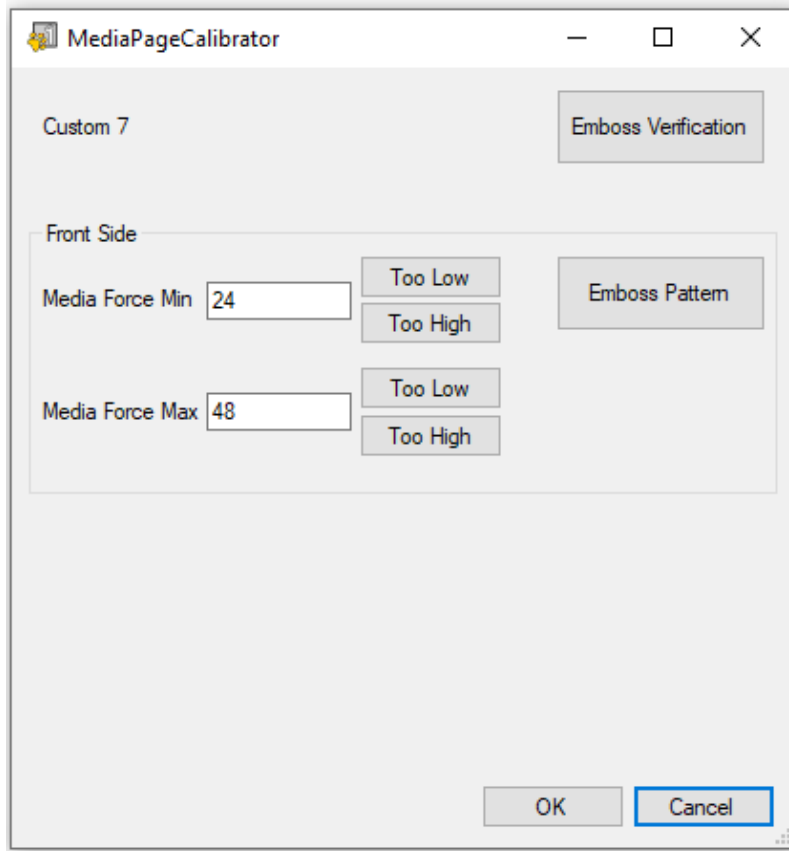

Shows Media Page Calibrator of Rogue Extension Program

From this dialog, you can print tests. Make sure to load your custom media to Rogue paper tray and select 'Emboss Pattern'. Evaluate the pattern that embosses on your Rogue. It shows a sample each of low embossed dots and high embossed dots. The low dots should just be noticeable by touch, where the high dots should show strong Braille dots. Use the 'Too Low' and 'Too High' buttons to adjust the Min and Max values according to your findings.

At the top right of the dialog, there is a button to initiate a printout for verification of your settings. If you are not happy with the outcome, feel free to repeat the calibration process.

Remember which custom media type setting you calibrated from 'Custom 7' through 'Custom 16', and use this setting in media type setting of device settings, or printing preferences.

Skew: If on embossed Braille text, dots 1, 2, 3, or 4, 5, 6 do not appear in a straight line underneath each other, this could be caused by the 'Skew' setting being off. In this case make sure to have paper loaded in the embosser and initiate a test print by selecting 'Print Skew Calibration'. From the printed test patterns choose the one that has the straightest vertical lines, counting the separated pattern sections from top to bottom starting with '1'. Enter the number of the corresponding pattern in the

edit box and press 'Apply'. After pressing 'Apply' and hearing the confirmation beep from the embosser, you may print the skew verification pattern, using button 'Print Skew Verification', to see if further adjustment might be necessary, or the outcome is satisfactory.

- **Network Tab**

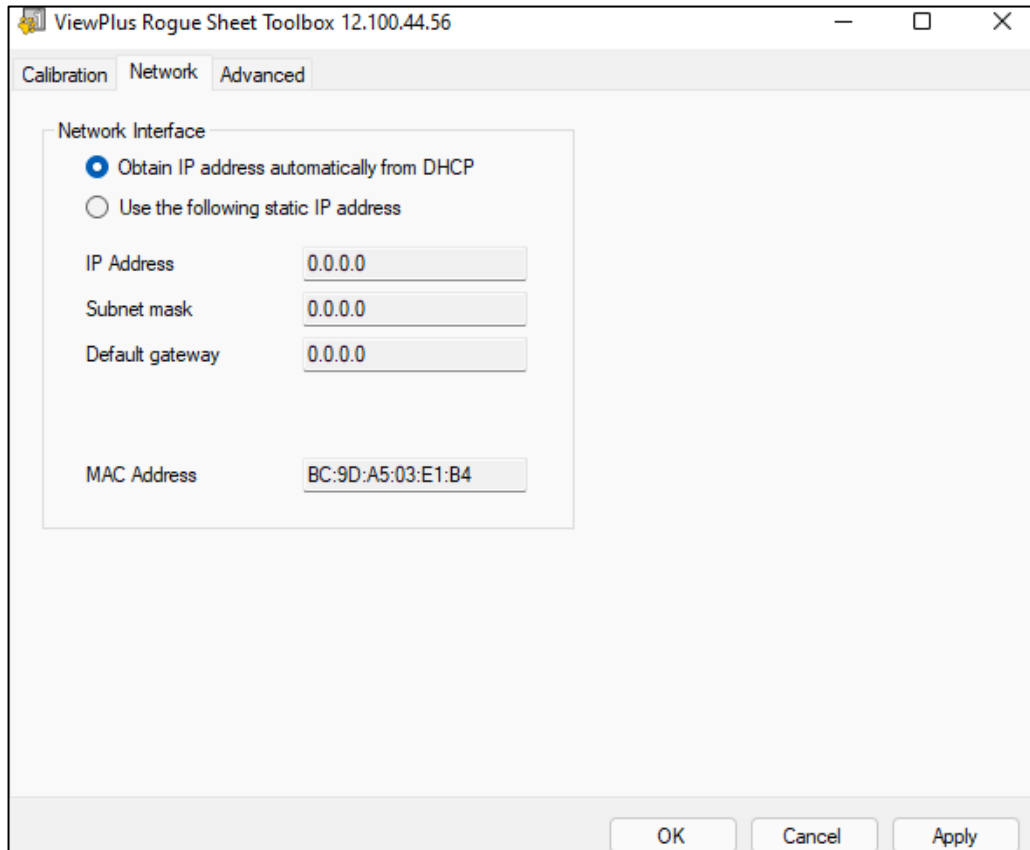

Shows Network tab of Rogue Extension Program

Network Interface: If using the VP Rogue via network connection, this tab gives opportunity to check network address settings, or enter static IP addresses manually.

The MAC address of your embosser will display, and it is also given on the bar code sticker in the back of the embosser.

- **Advanced Tab**

Usage: Within this section usage information is displayed. It includes the number of pages that have been printed and the number of hours of use, as well as the average solenoid lifetime remaining.

Tuning: These settings are for adjusting tactile embossing to match ink printing on another laser or inkjet printer to within a fraction of an inch.

- Forward Steps Per Inch – used to adjust the scaling of the paper rollers
- Edge Clearance – used to adjust the area at the top of the page where embossing is not allowed (data placed in the region is truncated by the firmware so no dots will be embossed here). A half inch is the default found to avoid any paper movement until the paper is firmly in the paper rollers. Setting this value to 0.4 inches will allow braille with only one braille line margin to print correctly for tools not using true margin settings.
- Top Of Form – Sets the vertical location where embossing starts
- Home Position – Sets the horizontal location where embossing starts

These settings will influence each other. If increasing the Forward Steps per inch to increase the relative vertical size of the embossed image to the ink image, the Top of Form setting will likely need to be reduced so embossing starts in the correct location.

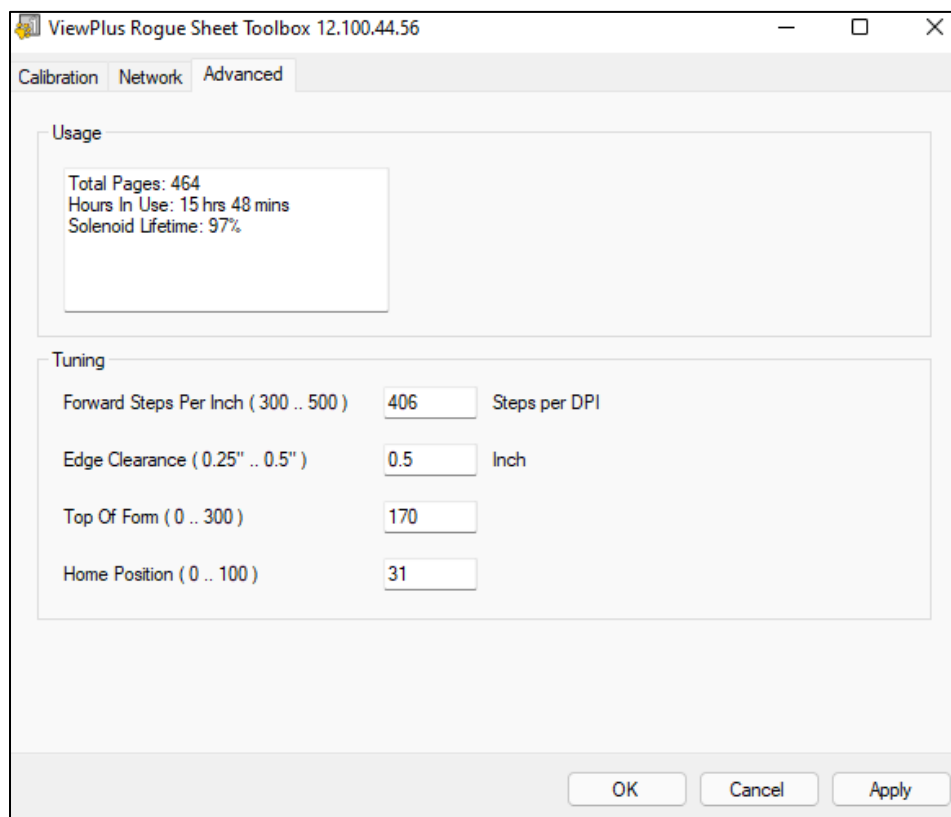

Shows Advanced tab of Rogue Extension Program

C. Printing Preferences

Printing Preferences contain settings for printing from Windows programs to your Rogue, which will affect the output of individual print jobs. To open the printing preferences dialog, choose the 'Preferences...' button on the 'General' tab of the 'Printer Properties' dialog.

Or from Window system control panel for 'Devices and Printers' choose 'Printing Preferences...' from context menu of the ViewPlus Rogue printer.

In addition, the printing preferences are accessible next to the printer selection from standard Windows print dialog when printing from most programs.

Layout tab

The printing preferences dialog will show three tabs. The Layout tab contains options pertaining to the page layout of the document on embosser output. See description of the controls below.

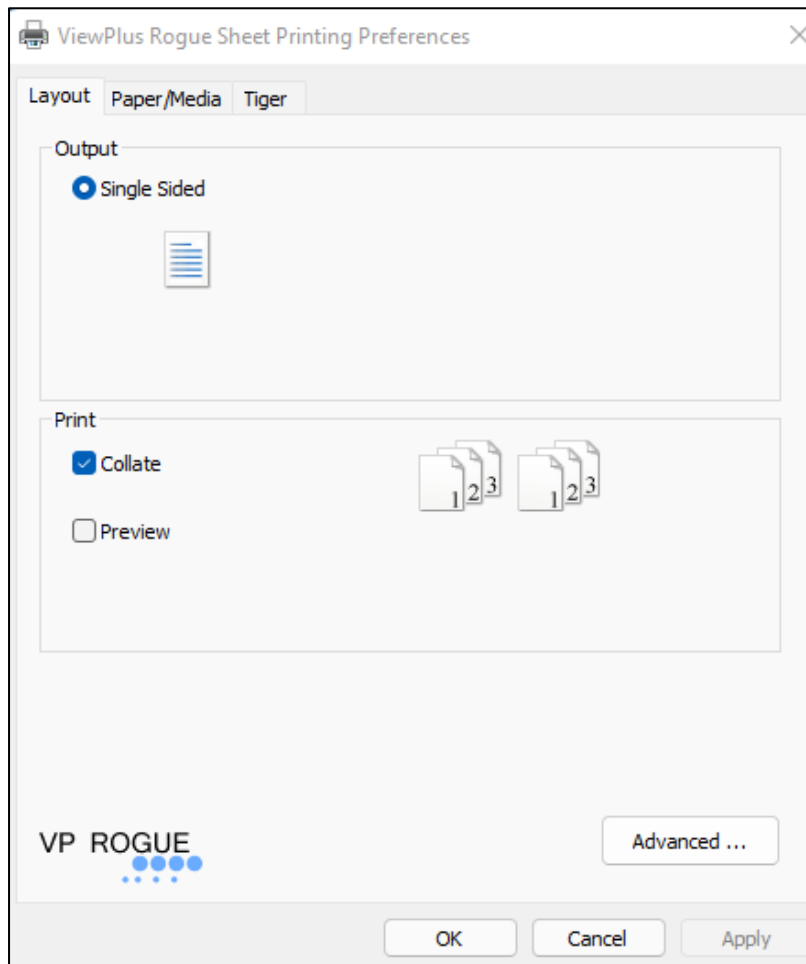

Shows Layout Tab

- **Output**

Single Sided: Only single sided embossing is available.

- **Print**

Collate: When the collate box is checked and multiple copies of a document are printed, one complete document will be embossed at a time. If the collate box is not checked, all copies of each page will be embossed before embossing all copies of the next page of the document.

Preview: If this option is checked, a preview of how the document will print will be shown in Tiger Viewer. If you are satisfied with the preview, choose the print option again within Tiger Viewer to send the print job to the embosser. Tiger Viewer also allows to save the output to a print file (PRN file), or to cancel the print action.

- **Advanced**

This button brings up a dialog containing advanced user options. In this case it is only one option:

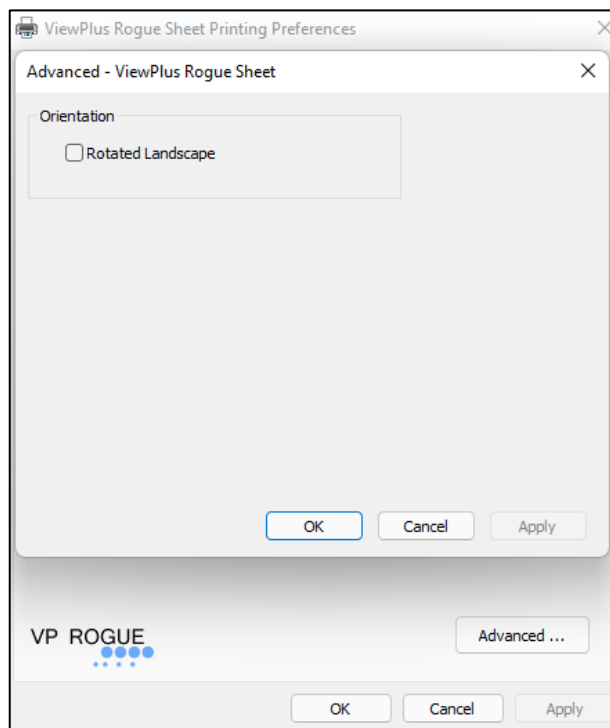

Shows Advanced view to rotate to landscape orientation

Orientation - Rotated Landscape: When checked, this option rotates pages in landscape orientation by 180 degrees.

Paper/Media tab

The Paper/Media tab contains options related to the type of paper or media being used for printing. Select the desired options for your media.

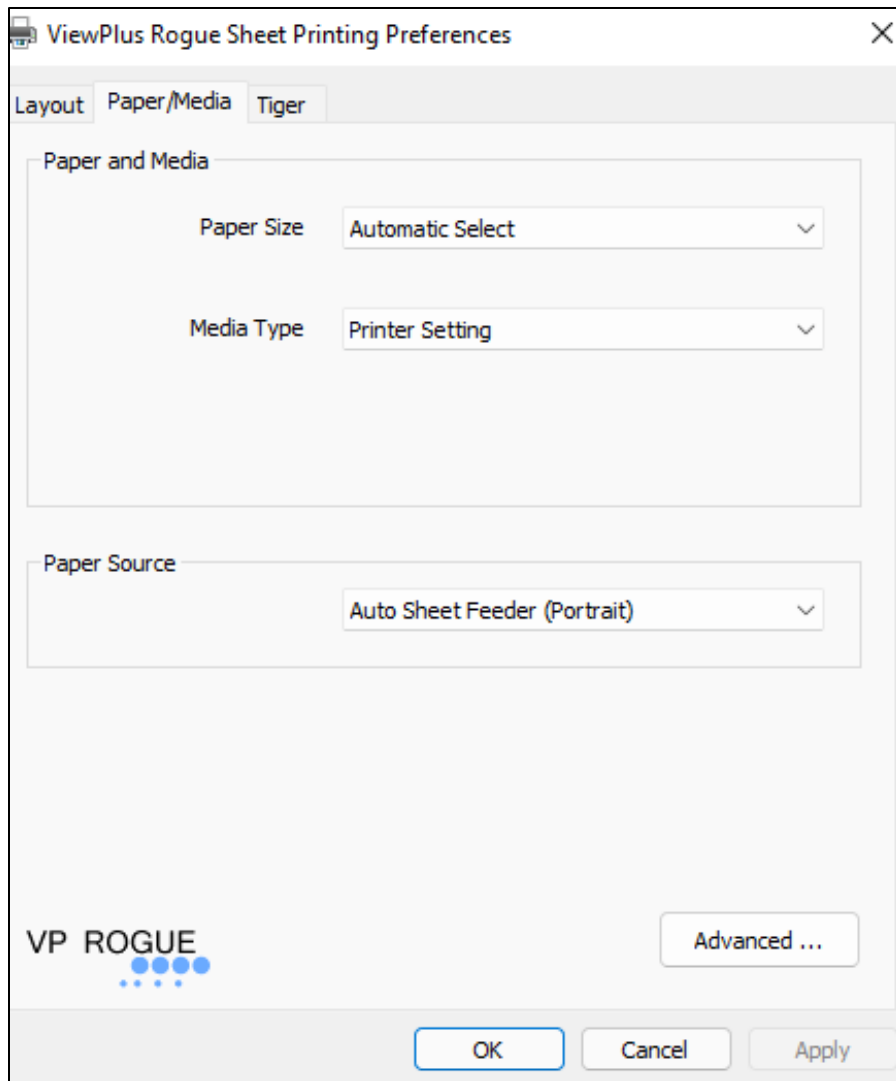

Shows Paper/Media Tab

- **Paper and Media**

Paper size: Select the paper size you are using from the list, or leave the setting at 'Automatic Select' to allow the paper size setting from the application you are printing from to be applied.

Media Type: Select the type of media you are using. The media type setting will determine the hammer punch force that is applied during embossing. Each preset choice of media type also shows corresponding paper weight in grams per square meter in brackets behind the media type name.

If none of the preset media type settings will result satisfactory embossing results, a custom media type calibration might be necessary as explained in section 'Printer Extension Program' above.

'Printer Setting' will apply media type setting as found in item "Media Type:" on list of Device Settings (see section IV.B. above).

- **Paper Source**

Auto Sheet Feeder (Portrait)/ Auto Sheet Feeder (Landscape): Tell the embosser in which orientation the paper was inserted into the tray to ensure correct rotation of the document output.

Advanced ... : The 'Advanced...' button will bring up another dialog, which allows you to create and manage custom paper sizes.

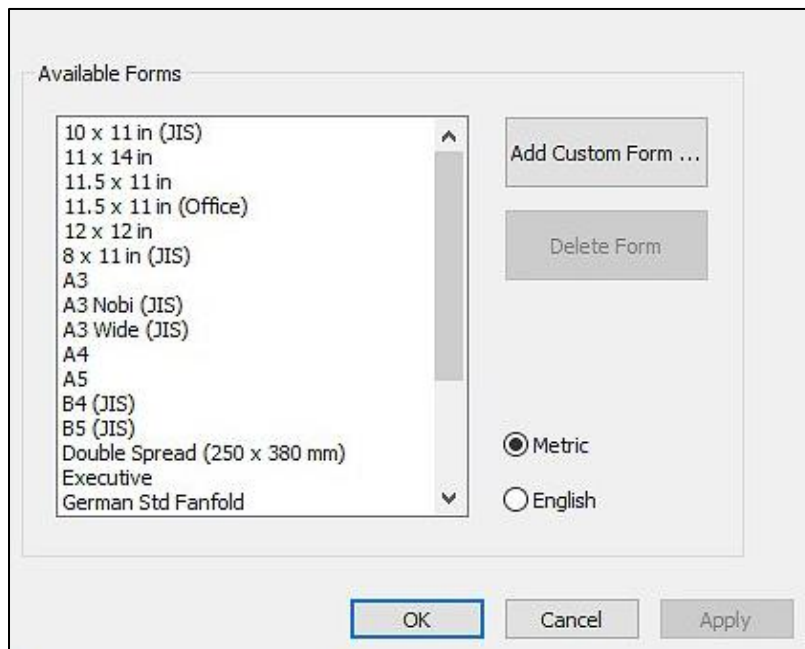

Shows Advanced options in Paper/Media settings

- **Available Forms**

All forms that are available for Windows document formatting when printing to the VP Rogue are listed in the display box, and dimensions of these forms are shown on the right upon selection of the form name.

Add Custom Form...: This button will open a new dialog where you have the opportunity to enter a new custom form name and define width and height for that form in either metric, or English units of measure.

NOTE: PAPER SIZES WIDER THAN 12 INCHES MAY NOT BE ADDED.

Delete Form: If the selected form from the list is a custom size, this button will remove the selected form.

Metric/English: Select either one of these systems to show dimensions of forms in corresponding units of measure.

Tiger tab

The Tiger tab contains controls for Braille and print output options as follows.

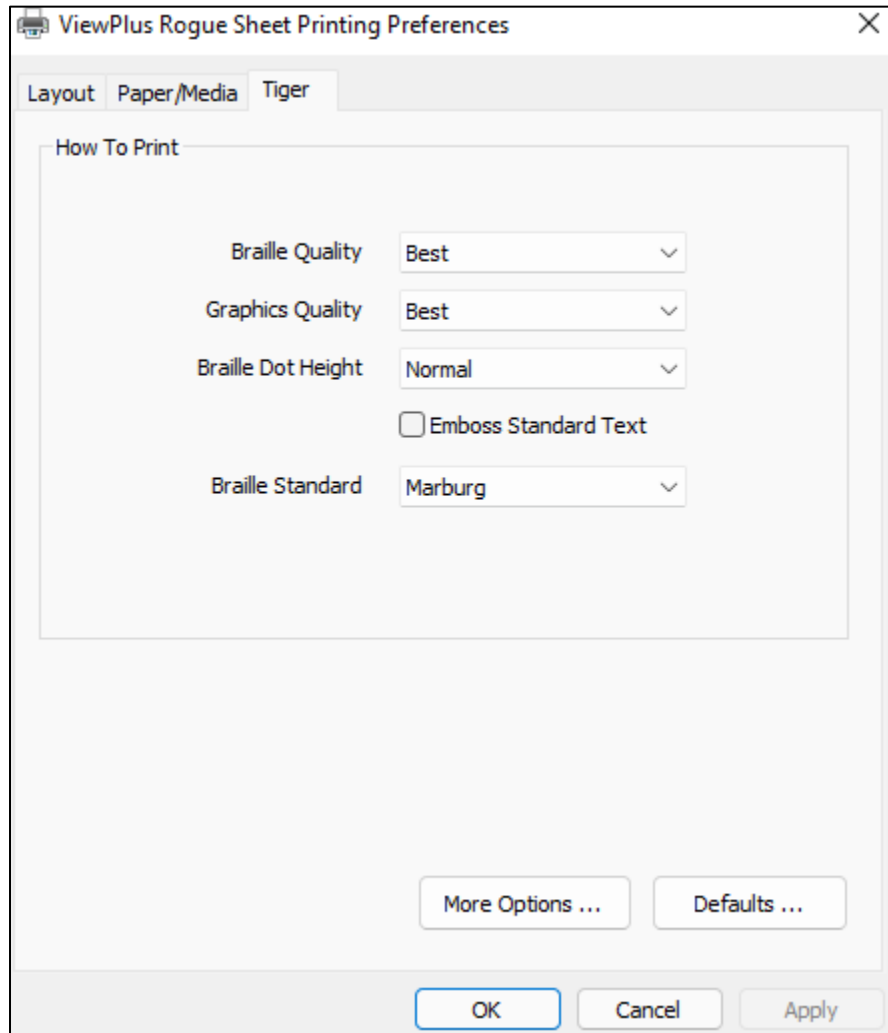

Shows Tiger Tab

- **How to Print**

Braille Quality: Select 'Draft', 'Standard' or 'Best'. Braille quality setting will influence accuracy in dots placement, and also shape of Braille dots. Please note, higher quality setting will slow down Braille embossing speed to some extent.

Graphics Quality: Select 'Draft', 'Standard', 'Best'. Printing with draft graphics quality will place dots in a square grid versus best quality will place dots with 100 dpi resolution as close to each other as possible. Best quality will yield highest possible accuracy on embossed shapes and outlines, but will take most time to print.

Tiger 20 dpi mode emulates Tiger embossing from the VP Max by forcing a 20 DPI X-Y grid. This mode will be faster than best mode where the dot spacing will be 20 DPI with dots placed on a 100 DPI grid.

Braille Dot Height: Select 'Low', 'Normal' or 'High' Braille dot height. Normal dot height sets the Braille dots to the same height as the highest graphics dots. Adjust the Braille dot height higher or lower to suit the reader.

Emboss Standard Text: When this is checked, standard text that is not translated to Braille will be embossed as image of the characters. This is helpful when used with a large font to print raised letters. When doing so, it is recommended to change the font color to grey instead of black since the paper might be getting torn embossing solid black.

Braille Standard: Choose from five different standards to define dot spacing for Braille text.

More Options ... : This button will bring up a new dialog with the following options.

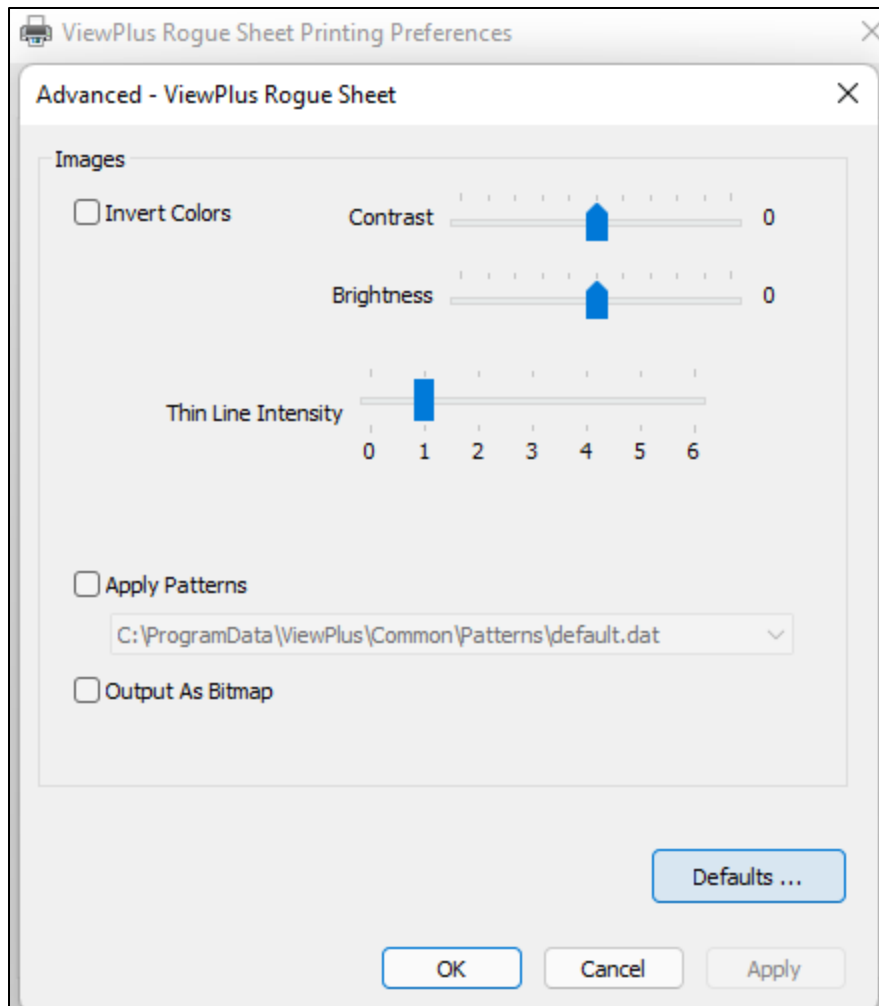

Shows the More Options dialog window

- **Images**

Invert Colors: Check this option if you want colors to emboss inverted, meaning lighter colors will emboss in higher dots, and darker colors will emboss in lower dots.

Contrast: The default setting is 0. The range is from -100 to 100. Increasing the contrast increases the dot height difference in respect to the color difference that the dots refer to. So the dot height difference of two similar colors increases.

Brightness: The default setting is 0. The range is from -100 to 100. Increasing the brightness can be useful to increase the intensity of all the colors. This option is most often used with images in which lines are thin and light.

Thin Line Intensity: In general, line thickness should be at least 1 ½ pt on your source image. If lines in graphics are too thin to emboss correctly, try using a higher thin line intensity by sliding the indicator to the right.

Apply Patterns: This option is only available if using TSS 8 or higher. Texture fill or pattern libraries can be previewed, edited, and created in Tiger Designer. Several example libraries are included with color mapping defined. Selecting this box will enable automatic texture fill for color mapping in the printer driver. Off by default.

Output As Bitmap: This option is an experimental feature to save the print job as a BMP file for additional optimization by tools under development at this time.

Defaults ...: The 'Defaults...' button will restore all settings to their factory default values after confirmation in additional message pop-up that follows.

V. Operator Panel

A. Button functions



Shows the operator panel with LED lights

LED1	LED2	LED3 and LED4
red	green	yellow

The buttons are described from left to right order:

Menu: In offline state press this button to enter the on-board menu to adjust settings for printing in legacy mode, for example when printing from a note taker instead of a Windows PC. To be able to follow the menu, it is necessary to have a powered speaker connected through the audio output jack. Please see section B below for further information on the on-board settings menu.

Up: Outside the on-board menu, this button has no function. Within the on-board menu, this button is used for navigation as described in section B below.

Down: Outside the on-board menu, tapping this button will move paper forward for a certain distance, attempting to bring paper to top of form position for printing, or to paper tear-off position depending on current situation. Holding the button will move the paper forward continuously as long as the button is held.

When running out of paper during printing, use this button to continue printing after new paper has been loaded to the embosser.

Within the on-board menu, this button is used for navigation as described in section B below.

Cancel: Holding this button during power on of the embosser will yield to embossing a demo page. Pressing this button during printing will stop the print job or clear error status. During stand-by, this button will switch the embosser between online and offline mode.

B. Operator Panel Menu

The VP Rogue provides an on-board menu to adjust device settings without connecting the embosser to a Windows computer. This is useful for adjusting settings prior to printing in legacy mode from a note taker device for example.

To enter the on-board menu, make sure the machine is in offline state first. This is indicated by the red light. Use the **CANCEL button** to toggle between online and offline state. Then press the **MENU button** to enter the on-board menu accompanied by audio messaging. To be able to listen to the messages, it is necessary to have a powered speaker connected through the audio output jack on the right side of the machine, since there is no on-board audio amplifier.

Once the menu was entered, use the **UP** and **DOWN** arrow **buttons** to step through the menu items.

Once the menu is entered, the **MENU button** will switch between "change setting" mode, and "continue navigation" mode. In "change setting" mode, the setting of the current menu item can be changed using the **UP** and **DOWN** arrow **buttons**. In "continue navigation" mode, the **UP** and **DOWN** arrow **buttons** can be used to continue stepping through menu items.

When navigating through the menu and pressing the **MENU button** for any menu item, the audio message will state the name of the menu item plus the current value. Now the **UP** and **DOWN buttons** will change the value. At any value, pressing the **MENU button** will bring you back to the upper menu level either with a changed value, or with 'no change'. The **CANCEL button** will always bring you back to upper menu level with 'no change'.

A value is saved when confirmed with **MENU button**, and the 'confirmed' message appeared accompanied by a beep of the embosser.

The **CANCEL button** will back up one menu level at any state. If message 'no change' appears, the current menu item in focus was not changed prior to exiting the menu, but all changes that were confirmed are saved.

The following table shows all menu items and their value range

Menu item	Description	Values
Form Size	Paper form size	11.5x11 inches, letter, custom, German standard fanfold
Language	Menu language	English
IP address	Will state IP address, but no change possible	
Double sided interpoint	Set double sided or single sided print mode	Short edge, long edge (both for double sided embossing), single sided
Dots per Character	Number of dots per Braille character	6, 8
Dot Quality	Quality setting for embossed dots	Draft, best, normal
Braille Dot Height	Adjust hammer punch force for Braille dots	Heavy, normal, light
Word Wrap	Truncate lines if word wrap is 'Off', or set to 'On' to have words wrap to next line if too long for current line	On, Off
Extra Line Spacing	Extra line spacing is added to normal single line spacing between Braille lines	0 to 1 inch, 0.05 inch increments
Braille Standard	Dot spacing in Braille text following the Standard that is selected	Marburg, Jumbo Braille, Korean, Micro Braille, US National Library, Library of Congress
Orientation	Orientation of paper	Landscape, Portrait, Inverse Landscape, Inverse Portrait
Right Margin	Right margin setting	0 to 5 inches, 0.05 inch increments
Left Margin	Left margin setting	0 to 5 inches, 0.05 inch increments
Top Margin	Top margin setting	0 to 5 inches, 0.05 inch increments
Form Width	Select a form width	11.5 inches, 8.5 inches, custom
Form Length	Select a form length	12 inches, 11 inches, custom

C. Machine status and alerts

As long as the embosser is online and connected properly to the computer, you will be able to get status messages and codes through the Printer Properties Service tab. Additionally, the VP Rogue is able to indicate status by audio alerts, and LED lights.

The following table shows machine status and corresponding alerts from the embosser.

Status description	Status code	Audio alert	LED lights indication
Online/Standby	10094	"Online"	LED2 on
Offline	10002	"Offline"	LED1 on
Embossing	10098		LED2 on, LED4 blinking
Paper load error	41100		LED2 on, LED3 and LED4 blinking
Invalid data			All LEDs blinking
Hardware error			All LEDs blinking
Network error	30027		
SD card error	30900 40083		
SD card missing	40100		
Power fault, or Machine temperature out of valid range			No lights at all

If one of the events below occur, please follow these instructions:

Paper load error: This could mean, there is no paper present at all when the embosser is trying to start printing. It could mean, paper ran out before the print job was completed. It could also mean, the paper path is blocked and no top of form could be found to start a new page. In any of these cases, make sure the paper path is free of any possible blockage and load paper properly to the tray with the stack sitting as low as possible within the tray. Press the arrow down button to begin, or continue printing. To cancel the print job at this point and clear the error, press the cancel button. If any other print job is waiting in the queue, the machine will try to continue with those print jobs after pressing the cancel button once.

Paper Jam: Remove the jammed paper according to the instructions in section VI.C. below, and press cancel to clear any error status before sending the print job again.

Print data error: If you notice wrong data output from the embosser, press cancel and send the print job again.

Carriage stall: If the carriage stalls, turn the embosser off and see if the paper path is clear following instructions in VI.C below to remove jammed paper. Turn the embosser back on. If this does not clear the error status, contact ViewPlus Support.

Any failure that can't be identified: Turn the embosser off and contact ViewPlus Support.

VI. VP Rogue Sheet - Paper Handling

A. Paper Loading

Your ViewPlus Rogue Sheet provides a paper tray that holds a stack of cut sheet paper. It will feed paper from the top down through the printer.

Getting perfect paper feeding is helped by good techniques. Many paper manufacturers ship paper that has sheets that are slightly stuck together at the edges. Riffling the paper stack helps break up these sticky pages so that pages do not try to feed together.

Follow the instructions below to load paper:

- Take a stack of cut sheet paper and place it, leading edge down, into the tray at the top of the embosser. You may load paper in portrait as well as in landscape orientation.
- Facing the embosser from the front, make sure the paper is aligned to the right side of the tray.
- Slide the left tray edge against the left side of the paper stack as indicated with arrow A in picture below. This will ensure to hold the stack registered to the right side of the tray.
- Do not push the paper stack down hard. Let the rollers pull the paper down. To help bringing it down manually you may push a horizontal rod towards the front, which you can reach through the opening at the right side of the tray slot, as indicated with arrow B in picture below.

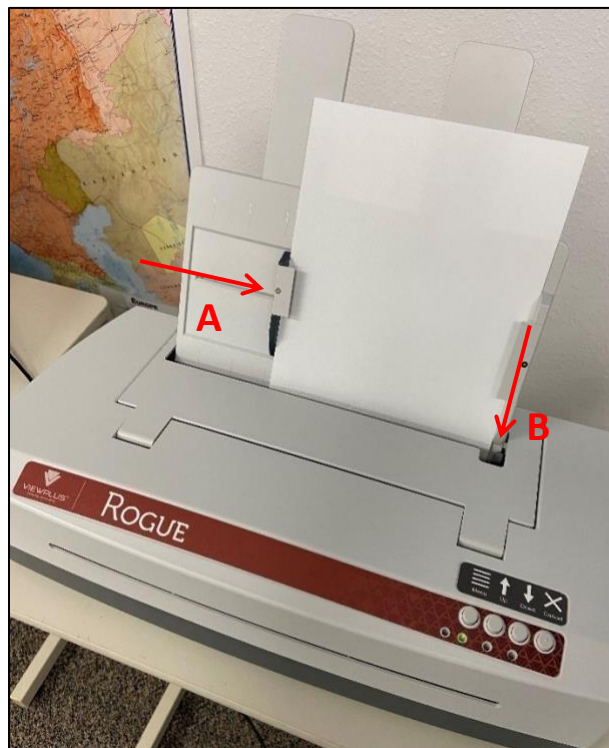

Shows paper tray loaded

B. Paper Feed Adjustment

Adjusting for different paper weights

The adjustment knob on the back of the Rogue Sheet (see picture below) is designed to accommodate for a wide range of different weight papers. The knob shows a pointer, indicating the adjustment setting for the pulling force on paper feed rollers. If the knob is turned with the pointer all the way up, the least pulling force is created on paper feed rollers. If the knob is turned with the pointer all the way down, the most possible pulling force is created on paper feed rollers. For intermediate settings it doesn't matter whether the pointer shows to the right or left – the settings are symmetric.

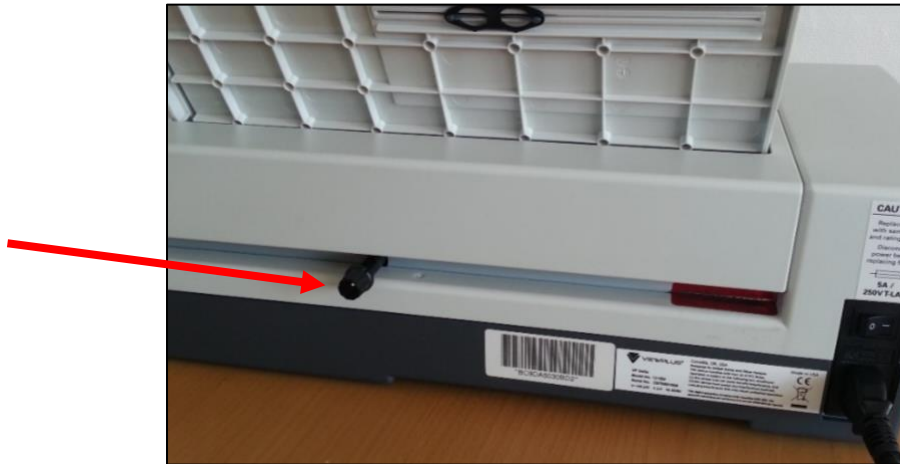

Shows the paper feed adjustment knob

Recommended settings:

- For light paper such as a copy paper type (~75 GSM), set the knob with the pointer all the way up
- For heavy paper (>150 GSM), set the knob with the pointer all the way down
- For any paper types in between, you may need to adjust to intermediate setting to obtain optimal paper feeding. Please start with the pointer all the way up and move slowly down while testing the feeds. To test the feeds, use the down arrow button of the operator panel. This will initiate paper feeding. You may adjust the knob while paper is trying to feed.

How to proceed in case of “no-feeds” or “multi-feeds”

If you get any “no-feeds”, turn the knob with the pointer more “down”. If there are “multi-feeds”, turn the knob with the pointer more “up”. It is probably best to start with the pointer further up and go down. No-feeds cause a bit of extra roller noise but otherwise do no harm. Multiple feeds can jam and require that they be pulled backwards out of the Rogue Sheet. However, this has occurred only with very light copy paper in our testing to this point.

C. Paper Jams

- If the embosser is indicating a paper jam, pull on visible paper on the output (front) side of the machine. Take care to distribute pulling force evenly across the paper to prevent tearing.

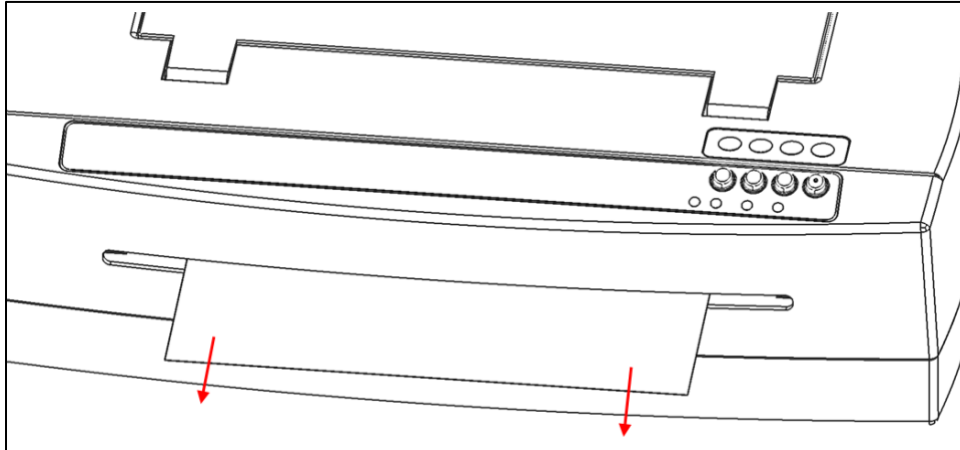

Shows paper removal towards front of machine

- If the paper does not completely pull out the front, remove the remaining paper from the tray, and then take the tray off itself, before trying to pull on any remaining paper from the top of the embosser. Take care to distribute pulling force evenly across the paper to prevent tearing.
- You may also try the down arrow buttons to support paper moving out of the machine.
- In the rare event, there are still scraps of paper left behind in the embosser, fold a thick sheet of paper in half, insert the sheet into the embosser, and move the sheet from side to side to free paper remnants as indicated in following illustration.

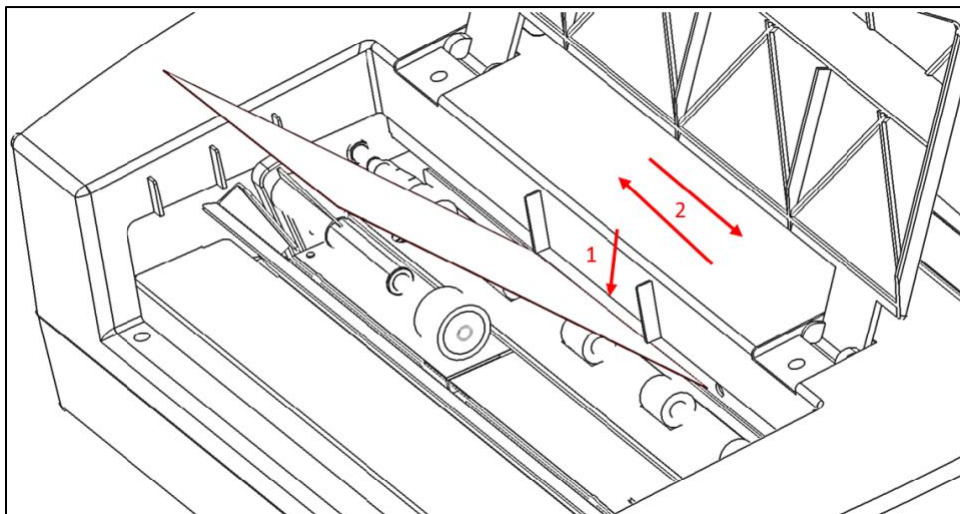

Shows manual paper clean out

VII. VP Rogue Trac - Paper Handling

A. Paper Loading

Your ViewPlus Rogue Trac comes with a tractor mechanism, feeding paper from the back. Follow the instructions below to load tractor feed paper:

- Open the paper cover by lifting the back edge of the housing top and rotating it towards the front of the printer.
- Lift the tractor flaps on both sides to reveal the tractor teeth.
- Facing the printer from the back, place the left side of the paper into the left tractor and close the tractor flap. Do not adjust the left tractor position. If necessary, adjust the right tractor position to fit into the right side of the paper:
 - Release the locking lever on the side of the tractor.
 - Slide the tractor to a position so it lines up with the holes in the paper.
 - Insert the paper into the tractor and close the flap.
 - Adjust the tractor so that the paper is tight.
 - Engage the locking lever.
- Close the paper cover.

B. Paper Jams

- If the embosser is indicating a paper jam, tear off the paper at the closest perforation to the embosser for both the paper input and output

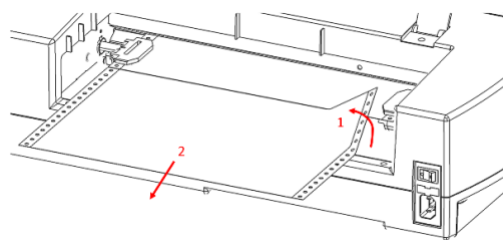
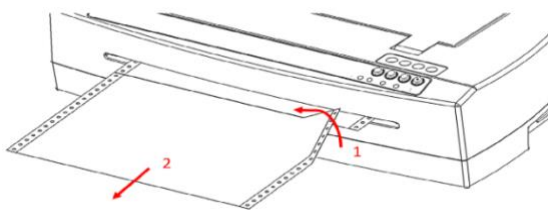

- Open the tractor feeder lid and release paper from the tractor pins if still engaged.

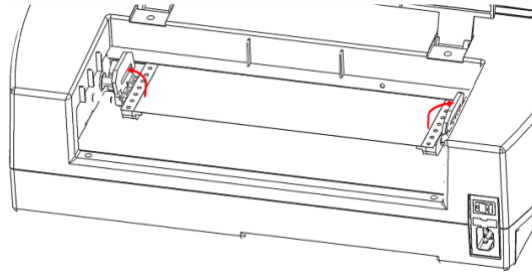

- Pull on visible paper on the output (front) side of the machine, take care to distribute pulling force evenly across the paper to prevent tearing.

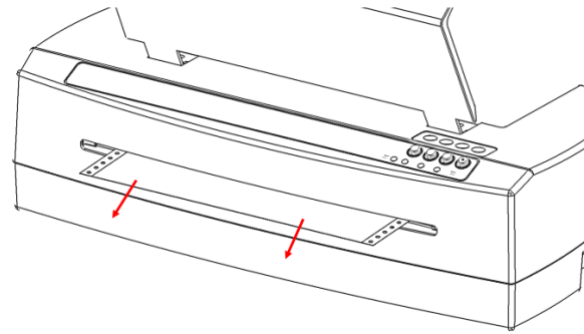

- If the paper does not completely pull out the front, remove any remaining paper from the rear of the embosser, take care to distribute pulling force evenly across the paper to prevent tearing.

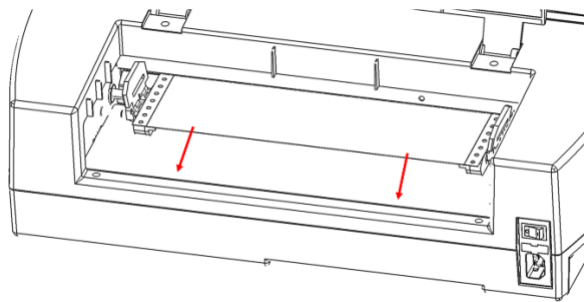

- You may also try the up and down arrow buttons to support paper moving out of the machine.
- In the rare event, there are still scraps of paper left behind in the embosser, fold a thick sheet of paper in half, insert the sheet into the embosser over the tractor feed, and move the sheet from side to side to free paper remnants.

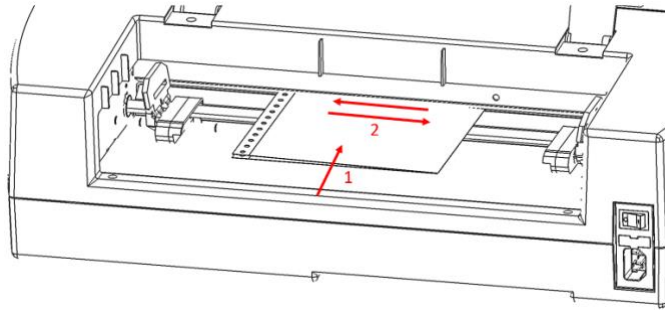

- Once the paper jam is clear, insert paper again, engage tractors, close the lid and reprint the document.

VIII. Braille, Translation and Printing

In general, the embossing technology will create a tactile representation of the screen image where darker colors will result in higher tactile dots and lighter colors in lower tactile dots.

Text will only print in Braille after it has been translated to Braille code and can be recognized as Braille text from the printer driver. In Windows applications, if the text is recognized as true text and not embedded as image, a non-contracted Braille output can be created by simply formatting the text to a Braille font as further described under B. below.

A. ViewPlus Tiger Software Suite

Within MS Office Word and Excel the ViewPlus Tiger Software Suite (TSS) provides direct tools for text to Braille translation in numerous languages and contraction grades. TSS includes easy translation of charts and graphs in MS Excel and provides further tools to easily create and edit tactile graphics originating from other Windows applications.

Please visit <https://viewplus.com/product/tiger-software-suite/> to find further information about the ViewPlus Tiger Software Suite solutions, including the TSS user manual.

B. Fonts

Braille and Tiger screen fonts are Braille fonts that install with the installation of the ViewPlus embosser driver. They can be chosen from any Windows program that includes Windows font selection. But text has to be handled like true text, and not show as embedded image, which is the case in some PDF Editor programs, for example.

Braille and Tiger screen fonts appear as standard text characters on screen, but emboss in Braille dot patterns. When applying these fonts, each print character is converted to one Braille character that corresponds to the ASCII code of that print character. There will be no contractions, or translation of symbols in the Braille output.

It is very important to use the correct font size for the correct dot spacing to be printed for Braille fonts. For 8 dot Braille fonts, like 'Computer' Braille, the point size needs to be set to 36. Other Braille fonts, indicated through a '29' or '36' in their font name, need to be set to point size 29 or 36, respectively.

Text characters, written in standard print screen fonts, like 'Times New Roman', or 'Arial', will not appear on embosser output, unless 'Emboss Standard Text' option is checked within Tiger tab of printing preferences. In this case, letters will emboss in shapes of print letters, but font size has to be at least something like 40 on Arial font before shape of print letters can be determined in tactile representation on embosser output.

C. Math and Braille

Create braille math documents using the Tiger Software Suite and MathType from Design Science. Insert text, graphics and math equations directly into a Microsoft Word document and translate to braille in one easy step. Equations will appear in both braille and ink allowing sighted readers to follow along. More information about braille math can be found on the ViewPlus website.

D. Printing

Once the printer driver is installed and printer properties are accessible, you are ready to emboss from any Windows program. For a general printing test out of MS Office Word follow these easy steps:

- Open the document to be printed in MS Word.
- Open the program's File menu and choose Print.
- On the Print interface, make sure the VP Rogue is selected. The default printer properties settings should be fine, but feel free to select printer properties and check selections within printer properties dialog, like Tiger printing options. Click OK on printer properties dialog when you are finished.
- Please note that any printing options showing within print interface of MS Office Word will have priority over printer properties dialog settings if they don't match.
- Click OK or Print to start the print job.
- When the printer is finished, it will eject the paper.

In general, ViewPlus printers follow the principle "What you see is what you get". The screen image is converted to tactile resolution and colors are converted to different dot heights on embossed output,

where darker colors are represented in higher dots (black = highest dot), and lighter colors are represented in lower dots (white = no dot).

Two new key features available with the VP Rogue embosser that deserve a mention:

1. The output can be matched to the layout of a color output from a third party printer to allow color ink to overlay with the braille text and graphics produced by the Rogue embosser
2. A pattern fill library is available to automatically replace colors of tactile pattern fill (when using TSS version 8 or higher).

A knowledge base, and tutorials on how to use ViewPlus embossers with various applications can be found under <https://viewplus.com/viewplus-support/>

IX. Software Packages

For pricing, ordering, and additional information on any of the following products consult the ViewPlus website www.viewplus.com or your ViewPlus representative.

A. Software Packages

- **Tiger Software Suite (TSS)**

The ViewPlus Tiger Software Suite (TSS) is the complete solution for producing Braille and tactile graphics by harnessing the full power of MS Word and Excel. The press of a button automatically converts and formats documents that were originally created for an ink printer.

Additionally, the Tiger Software Suite offers tools to ease creation and editing of tactile graphics.

- **MathType by Design Science**

MathType is an Add-in editor in MS Word for math equations. Equations can be entered using MathType editor and directly translated to LaTeX, Nemeth, or other Braille math using the ViewPlus Tiger Software Suite.

- **Audio Graphing Calculator (AGC)**

The ViewPlus Audio Graphing Calculator (AGC) is a self-voicing Windows application that provides access to scientific calculation and graphing for people who are blind or dyslexic. It includes a standard on-screen calculator and a powerful function evaluator as well as the capability of computing and viewing functions visually and as an audio plot. The audio tone plot gives AGC users access on a time scale comparable to access by people without print disabilities to visual plots on standard graphing calculators.

X. Training, Warranty, Maintenance and Support

For additional information about any of the below, please don't hesitate to consult the ViewPlus website www.viewplus.com or contact your ViewPlus sales representative.

A. Training

ViewPlus provides two training methods

- 1) Video tutorials/documentation downloadable from our website, and
- 2) Live on-line training sessions with a ViewPlus Support Specialist.

B. Maintenance

It is important to follow the safety instructions as stated under I.C.

Dot quality should be monitored; poor alignment of the hammer tips to the receiving dyes can cause permanent damage to the ViewPlus embosser.

Updates can be downloaded from the ViewPlus Technologies website. Please check the website occasionally for our latest developments, too.

C. Support

In addition to support material on our website please do not hesitate to contact us for your technical support questions:

- Contact your ViewPlus embosser sales representative if you did not purchase directly from ViewPlus Technologies
- E-mail to support@viewplus.com, or
- Call the ViewPlus support hotline at +1 (866) 836 2184, or the ViewPlus Technologies office at +1 541 754 4002 (Pacific Standard Time Zone).

D. Warranty

For information on your product warranty, please visit our website and select the warranty details link under category support. Direct link: <https://viewplus.com/viewplus-support/warranty-details/>

Extended Warranty

For extended warranty options please contact your ViewPlus representative, or the dealer the embosser was purchased from.