

**SPECIAL NEEDS**  
**COMPUTERS**   
**1-877-724-4922**

# **CLOVER 6**

Handheld Video Magnifier

**User Guide**

---

## Rev B

# Contents

<b>Precaution</b>	<b>1</b>
<b>Quick Start</b>	<b>4</b>
Overview.....	4

---

---

Compositions .....	6
Accessories .....	12
Stand .....	17
Handle .....	18
<b>Operation</b>	<b>21</b>
Power Button .....	21
Setting Menu .....	21

---

---

Magnification .....	26
Brightness.....	27
Color Mode .....	28
Lighting .....	30
Freeze .....	31
Image Storage .....	32
Playback.....	36

---

---

Line and Mask .....	39
Live Panning .....	44
Focus Control .....	45
Power Frequency .....	49
Memory .....	49
Auto power saving .....	50
Restore .....	50

---

---

Hardware Reset.....51

**Troubleshooting 52**

The unit does not turn on .....52

Black screen or White screen .....53

The image does not change .....54

Smudges or blemishes on the screen .....55

**Specifications 56**

---

## Precaution



Before using Clover 6 for the first time, you must charge its battery. Refer to **Battery and Charging** section for more details.



Always operate the unit in a place where the temperature is between 10° and 35°C (50° and

95°F).



Keep the unit away from wet areas, rain, and other sources of liquids. Do not submerge the unit.





Do not attempt to repair the unit. Any unauthorized attempt will void the product warranty. Contact your distributor to service.



Use the supplied power adapter and battery.

## Quick Start

### Overview

Thank you for purchasing CLOVER 6.

CLOVER 6 is a handheld video magnifier, and all operations are supported by the high contrast tactile buttons. Equipped with the 1080P FHD touch screen,

hand gesture provides easier and more natural way for certain features.

Dual 13M cameras and fast switch mechanism to fulfill the full-range distance viewing requirement. When stand on the table, amazing details reveal with 2-35 times lossless magnification.

The handle is flexible enough to be rotated to any angles and satisfy all holding requirements, which is also friendly for left hand user. Transform the handle into stand for comfortable desktop reading.

## Compositions

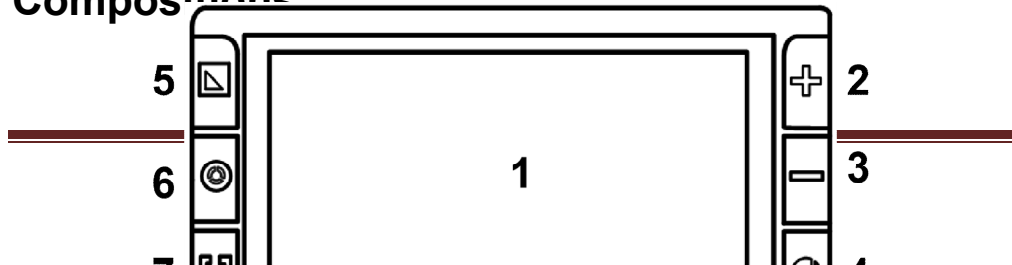

1. LCD screen

2. Zoom In

3. Zoom Out

4. Freeze

5. Enhanced Color

6. True Color

7. Locate

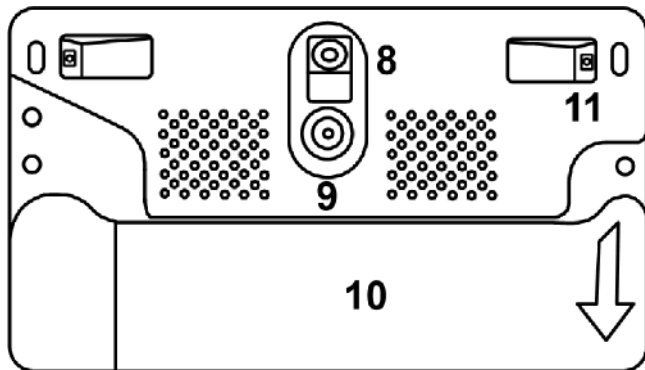

8. Near View Camera

9. Distance Camera

10. Handle

11. LED Lights

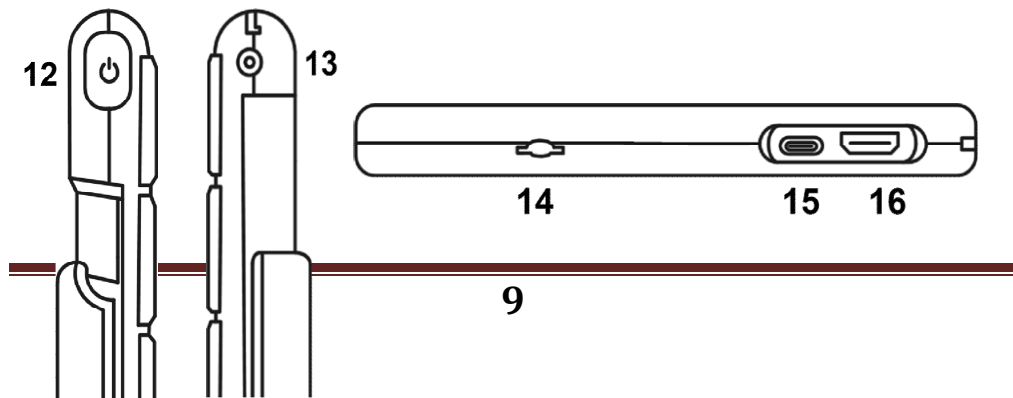

12. Power Button

13. Charging Port

14. Micro SD Card Slot

15. USB Port

16. HDMI Port





User Manual

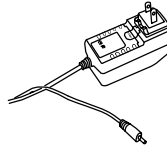

Power Adapter



Cleaning Cloth

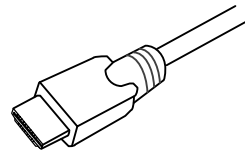
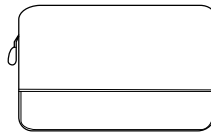

Strap

Pouch

HDMI Cable

## Accessories

### Charging the battery

Connect the supplied power cable to the unit's charging port, and connect the power adapter into an AC outlet to start charging.

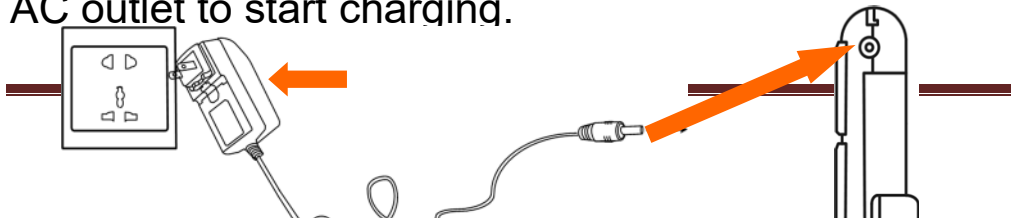



## Power LED

- ❑ Charging when the unit is off, the power LED will be green, and then auto turn off when fully charged. A fully Charging will take about 2.5 hours, and will support the unit working continuously for about 3 hours
- ❑ Charging when the unit is on, the power LED will be green

- ❑ When the unit is on and the power adaptor is not connected, the power LED will be green when the battery is high and will be red when the battery is low. When the red light starts to flash, you will need to charge the battery.
- ❑ When in the Sleeping Mode, the LED light will be yellow.
- ❑ You can also check the battery status by pressing the power button.



## Stand

Unfold the stand as the following figure shows.

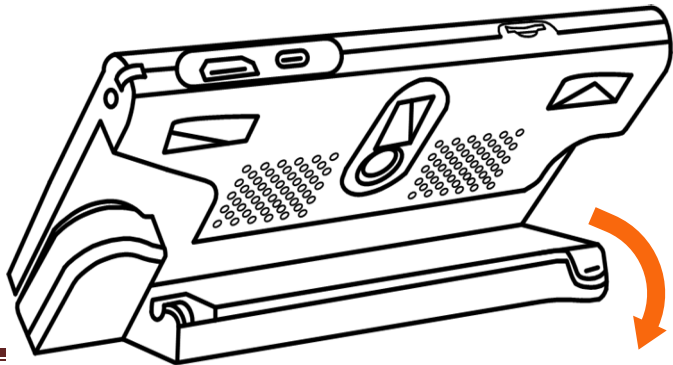

## Handle

Rotate the handle as the picture shows and hold it at your most comfortable position.

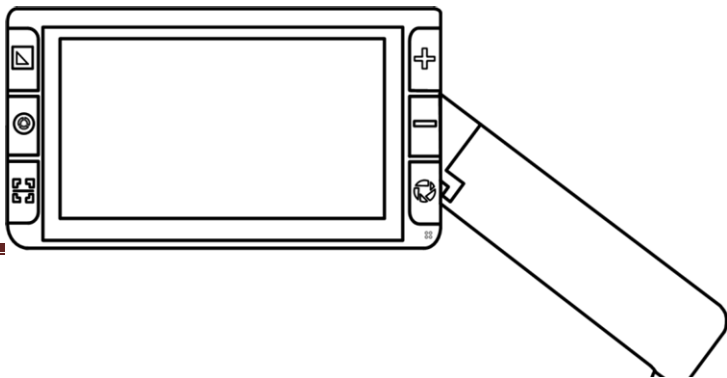





When the handle is open as picture shows, the device will switch automatically from distance camera to near view camera.

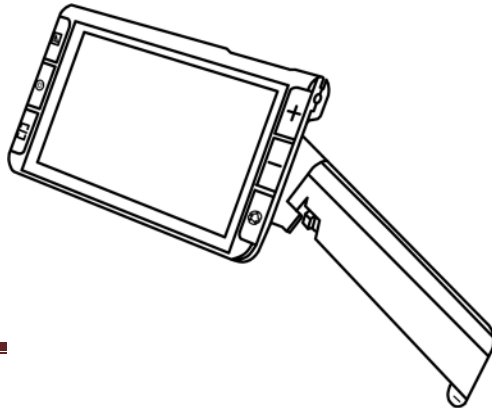









## Operation

### Power Button

- ❑ Press and hold the Power button  for 2 seconds to turn on the unit when it is off.

- ❑ Press and hold the Power button  for 2 seconds when it is on to get into choosing page: Sleeping Mode  or Turn Off . Tap the Sleeping icon  or no operation in 3 seconds to get into Sleeping Mode. When in Sleeping Mode, long press Power button  for 3 seconds to wake up the unit.
- ❑ When the unit is on, press the Power button  to enter the Setting Menu.

- ❑ Press other buttons when holding the Power button  will make combo function, refer to the following instructions for more details

## **Setting Menu**

- ❑ Slide the corresponding control bar to adjust volume/brightness.



Volume Control Bar



Brightness Control Bar

- Use tap gesture on the specific icon to activate/inactivate the setting.



Auto Focus



LED Light



Vibration



Power saving



- No operations for 8 seconds or short press the Power Button  to exit.

## Magnification

- ❑ Press the Zoom In button  $+$  / Zoom Out button  $-$  to increase/decrease magnification, and hold the button for continuous increasing/decreasing.
- ❑ In addition to the Zoom button, use the pinch and zoom gesture on the touchscreen to adjust the zoom level.
- Magnification Range: 2x – 35x (near view)







## Brightness

In addition to control bar, hold the Power button  and press the Zoom In button  /Zoom Out button  to increase/decrease the screen brightness.

## Color Mode



A color mode is a pre-defined color combination. Full color mode is suitable for picture, map viewing, and enhanced contrast mode is combined with different foreground and background colors and can help to read clearly.

- Press the Enhanced Color button  to cycle through the color combination list

- ❑ Press and hold the Enhanced Color button  for 3 seconds to enter the Customized Color Page, use the tap gesture to activate/inactivate the enhanced color combination.
- ❑ No operations for 8 seconds or tap the Exit icon  or long press the Enhanced Color button  to exit the Customized Color Page.

❑ Press the True Color button  to quickly return to the full color mode.

## Lighting

In addition to the setting menu, hold the Power button  and press the Freeze button  to turn on/off the LED lights.

## Freeze

Freezing an image on the LCD screen can be useful for further reading, and also further zooming in or zooming out or changing the color mode for a better view. The brightness adjusting is not allowed when freezing.

- Press Freeze button  to lock/unlock the image.

- ❑ For the locked image with increased magnification, you can use the gesture to navigate around freely.

## Image Storage

- ❑ Long press the Freeze button  for 3 seconds to store the current image.

- ❑ The Voice Record icon will appear after the storage. Tap and hold the Mic icon to begin the recording and release the icon to finish (or press the Locate button  to record).



- ❑ You can replay the recorded voice by pressing the Play Icon (or pressing the Freeze button  )



- You can repeat recording the voice but only the latest record will be saved with the image.
- No operations for 5 seconds or tap other inactive area or press the Power button  to close.
- For a better recording quality, please approach to the Mic as the picture shows and speak aloud.







**Note:** When the saved images reach to the maximum capacity (2 GB, Memory Full icon appears),



you will need to delete some pictures first in Playback mode before the next successful saving.



## **Playback**



- Press the True Color button for 2 seconds to enter the picture gallery. Page up/down the gallery by the slide bar on the right side of the screen.
- Tap the picture to choose (or press Zoom button) and the highlighted thumb picture with the voice

label will play the recorded voice automatically. Tap again (or press the Freeze button ) to playback the picture.

- ❑ You can view and navigate the image with the same operations described in the Image Freeze. Press the Freeze button  to return to the gallery.
- ❑ When in the gallery, select the target image which needs to be deleted, tap the trash icon  (or

press the Locate button ) and the same trash label will appear right on the image. Tap the trash icon  again (or press the Locate button again ) to delete or any other buttons/places on the screen to cancel.

- When in the galley, tap the trash icon  (or hold the Locate button ) for 5 seconds to delete all the

images. Tap the trash icon  (or press the Locate button  ) again to confirm or any other buttons/places on the screen to cancel.

## **Line and Mask**



Press the Locate button  to switch among different Reading Line & Mask modes. The Live-panning function is still available.



- **One horizontal line**

- Press and hold the Locate button  and use finger slide up/down on the screen to change the position of horizontal reading line.



- Press and hold the Locate button  and slide left/right to decrease/increase the width of the line.

- **One vertical line**

- ❑ Press and hold the Locate button  and slide left/right to change the position of vertical reading line.
- ❑ Press and hold the Locate button  and slide up/down to increase/decrease the width of the line.
- **Horizontal mask**

- ❑ Press and hold the Locate button  and slide up/down to change the position of the masks.
- ❑ Press and hold the Locate button  and slide left/right to narrow/enlarge the distance between the masks.
- **Vertical mask**



- ❑ Press and hold the Locate button  and slide left/right to change the position of the masks.
- ❑ Press and hold the Locate button  and slide up/down to enlarge/narrow the distance between the masks.

## Live Panning

In the higher zoom level, use slide gesture to navigate the image for seeing more without moving the paper.



- Quickly tap the image center twice to re-center the image.

- ❑ Quickly tap the image edge twice to jump to the start/end point.

## **Focus Control**

The autofocus system works well in the most situations. In addition, some methods are provided to control the focus.

- ❑ Tap on the screen for 2 seconds to trigger the focus manually.

- ❑ In addition to the setting menu, press the Power button  and Locate button  to enable/disable the auto focus. Disable the auto focus is especially useful for handwriting to prevent the fault focus on the hand or pen.

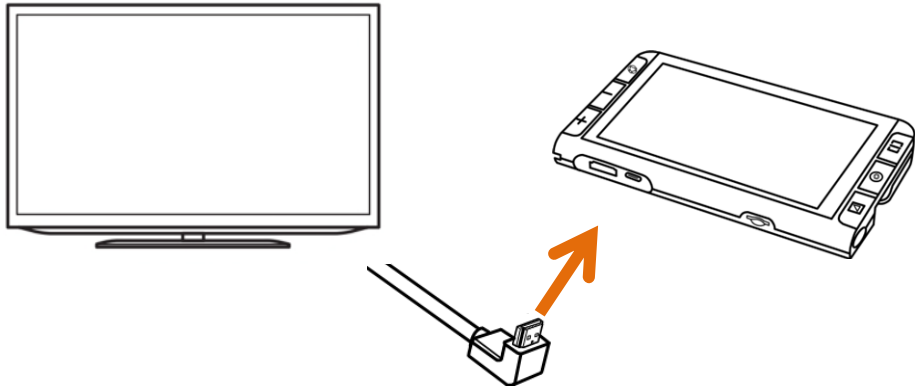

## **HDMI Output**

Connect to the external screen for a better and larger viewing.



## Power Frequency

Power Frequency provides the options of 50HZ and 60HZ power frequency according to customer region.

Long press the Power button  + Enhanced color button  for 3 seconds can adjust the frequency.



## Memory

The unit will memorize automatically the most recent settings such as color mode, magnification, beep when power off normally and use them in the next power on

## Auto power saving

If no operation and no moving for over 5 minutes, the unit will get into Sleeping Mode automatically and will turn off in 10 minutes with no further operation.



## Restore

- Hold the Freeze button  and the Locate button  at the same time for 3 seconds to reset to the



default factory settings. Auto power off when resetting is done.

## Hardware Reset

When the unit is hung(can't be turned off), press the Power  +Freeze button  +Zoom Out button  at the same time to trigger the hardware reset.

## Troubleshooting

### **The unit does not turn on**

- Connect to the power adapter
- Charge the battery

## **Black screen or White screen**

- If the unit is sitting on a flat pure surface, the screen may be black or white, Lift the unit off to ensure change happens.
- Adjust the magnification
- Adjust the color mode
- When the unit is connected to TV, the screen is black

- Restart the unit

## **The image does not change**

- If the unit enter the freeze mode, the image will not change
- Press power button to check the current status
- Restart the unit

## **Smudges or blemishes on the screen**

- Adjust brightness
- Clean the LCD screen and camera

Please contact your local distributor if problem is not solved

## Specifications

- **Display:** 5.5 inch IPS touch screen, anti-glare  
Screen Resolution: 1920\*1080

- **Camera:** Dual 13M auto-focus Camera  
Video Resolution: 1920\*1080
- **Magnification:** Approximately 2x ~ 35x
- **Color Mode:** Nature color  
Up to 16 user-defined Enhanced Colors
- **Brightness:** LCD brightness adjustable
- **Video Mode:** Near-view, Distance-view

- **Vibration:** Screen vibration feedback On/Off control
- **Snapshot:** Image Storage and Playback  
Storage capacity: approximately 2GB
- **Locate:** Reading Line/Mask function
- **Size:**  $\leq 160 \times 91 \times 21$ mm (Device folded)
- **Weight:**  $< 265$  grams (Battery included)
- **Battery:** Nearly 3 hours continuous use



Charges in approximately 2.5 hours

- **Power Adapter** Input: 110-240V; Output: 5V/3A