

# USER MANUAL



Groupe  
**Synetik**  
Group

The Synetik Group Inc. thanks you for the trust you have placed in us by choosing the SKY multi-positioning standing frame.

SKY is a piece of equipment where functionality is combined with principles of ergonomics and safety.

The Synetik Group Inc. suggests that you carefully read this manual in order to fully understand its contents and operation.

This will help you quickly become familiar with SKY, and you will also find many practical tips for using it safely and effectively.

By following our advice, we will help you achieve your development and rehabilitation goals.



Caroline Saulnier  
President

# INDEX

<b>Product labeling</b>	<b>3</b>
<b>Intended use</b>	<b>3</b>
<b>Warranty</b>	<b>3</b>
<b>Product history record-keeping</b>	<b>4</b>
<b>Product training</b>	<b>5</b>
<b>Safety information</b>	<b>5</b>
<b>Required tools</b>	<b>7</b>
<b>Unpacking and assembly</b>	<b>7</b>
<b>User transfer procedures</b>	<b>10</b>
<b>Frequent adjustments for daily use</b>	<b>11</b>
<b>Cleaning and maintenance</b>	<b>15</b>
<b>Daily inspection</b>	<b>15</b>
<b>Annual inspection, maintenance, and spare parts</b>	<b>16</b>
<b>Maintenance service</b>	<b>16</b>
<b>Storage</b>	<b>17</b>
<b>Reuse by a new user</b>	<b>17</b>
<b>Technical specifications</b>	<b>18</b>
<b>Contact us</b>	<b>18</b>

## 1. PRODUCT LABELING

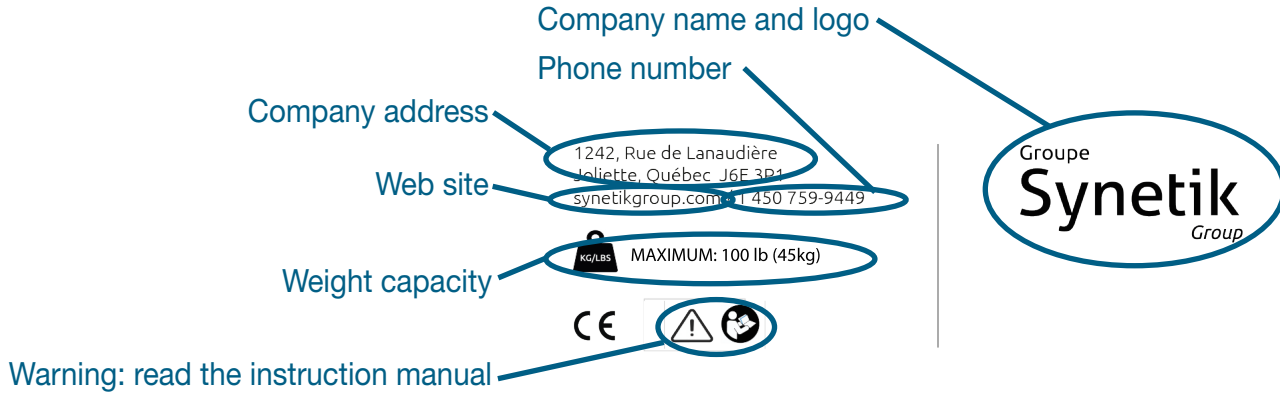

## 2. INTENDED USE

The Synetik SKY is designed to be used in a standing position, at home or at school. The standing position promotes normal hip development, muscle strengthening, and contributes to psychological well-being.

This multi-positioning standing frame is available in three sizes to meet the requirements and needs of children with reduced mobility.

	Maximum user weight
<b>Size 1</b>	45kg (100 lb)
<b>Size 2</b>	72kg (160 lb)
<b>Size 3</b>	72kg (160 lb)

## 3. WARRANTY

### 3.1 WARRANTY CONDITIONS

The warranty coverage is extended to the original purchaser for 10 years. Sky multi-positioning equipment. This warranty applies to the Sky multi-positioning equipment (“the product”). Synetik Group Inc. (“the company”) will repair or replace defective products due to material or manufacturing defects under the following conditions:

**Frame:** Lifetime warranty for the original purchaser, subject to terms, limitations, and conditions.

**Gas cylinder:** One (2) year warranty for the original purchaser, subject to terms, limitations, and conditions.

**Straps:** One (2) year warranty for the original purchaser, subject to terms, limitations, and conditions.

**Other components:** Coating, cover, padding, plastic parts, rubber parts, wheels, bearings, and other parts not specifically identified above, which are all warranted against material and manufacturing defects for three (2) years from the date of original purchase, subject to terms, limitations, and conditions.

### **3. WARRANTY (continued)**

#### **3.2 WARRANTY TERMS**

This warranty will be in effect from the original purchase date for the consumer. Any defective Product must be delivered to Synetik Group Inc. or its authorized local dealer, at the purchaser's expense, for warranty inspection. Return transportation charges will be prepaid by Synetik Group Inc. You can contact Synetik Group Inc. at 450-752-8818 for authorized dealers in or near your location.

#### **3.3 LIMITATIONS AND EXCLUSIONS**

The above warranty does not apply to (a) a serial-numbered product if the serial number has been removed or defaced; (b) any product subject to neglect, abuse, misuse, improper operation, maintenance or storage, or damage beyond the control of Synetik Group, as determined by Synetik Group Inc.; (c) defects resulting from failure of the purchaser to follow instructions. Any modification or addition to the product of unauthorized, non-manufactured or non-supplied parts by Synetik Group Inc. Repair or replacement by the Synetik group of a defective part or product shall be the sole and exclusive remedy of the purchaser under the warranty. Labor/repair service charges are not covered by this warranty and are not the responsibility of Synetik Group Inc.

The foregoing warranty is exclusive and in lieu of all other warranties, express, implied or statutory, including any warranties of merchantability and/or fitness for a particular purpose. In no event shall Synetik Group Inc. be liable for indirect or consequential damages.

Some states do not allow limitations on how long an implied warranty lasts or the exclusion or limitation of incidental or consequential damages, so the above limitations or exclusions may not apply to you. This warranty gives you specific legal rights, and you may also have other rights which vary from state to state.

### **4. PRODUCT HISTORY RECORD**

Your Synetik product is classified as a Class 1 medical device and as such, should only be prescribed, configured or reissued for use by a technically competent person who has been trained in the use of this product. Synetik Group Inc. recommends that a written record be kept to provide details of all configurations, reissue inspections, and annual inspections of this product.

### **5. PRODUCT TRAINING**

Your Synetik product is a prescribed Class 1 medical device and as such, Synetik Group Inc. recommends that parents, teachers, and caregivers using the equipment be informed of the following sections of this user manual by a technically competent person:

- Section 6: Safety information
- Section 9: User transfer procedures
- Section 10: Common settings for daily use
- Section 12: Daily product inspection

Synetik Group Inc. recommends that a written record be kept of all those who have been trained in the correct use of this product.

## 6. SAFETY INFORMATION

### 6.1 GENERAL INSTRUCTIONS

- Always read the instructions before use. Failure to read and follow the instructions, especially regarding moving parts, can be dangerous for the user.
- Use only components approved by Syntetik with your product. Never modify the product in any way. Failure to follow instructions can endanger the user or caregiver and will void the product warranty.
- If in doubt about the continued safe use of your product or in case of parts failure, stop using the product and contact our customer service or your local dealer as soon as possible.
- The product contains components that could present a choking hazard for young children. Always check that buttons and locking bolts within the reach of the child are tight and secure at all times.
- Clean the product regularly. Do not use abrasive cleaners. Regularly perform maintenance checks to ensure that your product is in good working condition.
- Make sure the Prescriber has confirmed that the product is properly configured; if the product has not been configured by your Prescriber, DO NOT USE.
- Ensure that all persons handling the product are familiar with its operation and have read the user manual.
- The product is intended for indoor use and when not in use, should be stored in a dry place that is not subject to extreme temperatures. The safe operating temperature range of the product is +5 to +40 degrees Celsius.
- Stop using this product if it is damaged or broken.
- If, unexpectedly, a serious incident should occur with the product, please report it immediately to our company and the appropriate authorities.
- We reserve the right to make technical modifications. This may result in discrepancies between your product and its presentation in the media.

### 6.2 SAFETY INSTRUCTIONS

- Syntetik Inc. recommends that the user should never be left unsupervised when using this medical device. The user may slip or fall without supervision and suffer serious injury. It is the sole responsibility of the person caring for the user using this medical device to ensure the user's safety in the device if left alone.
- It is essential that Syntetik Group products be carefully inspected at least once a year and periodically reviewed by a qualified Prescriber for proper use and appropriate to the user's needs. The examiner is responsible for ensuring that any product is safe and stable during use, paying particular attention to users whose clinical presentation or body size may have changed since the initial acquisition or when the user now displays difficult behaviors and movements that compromise product stability such as exaggerated swaying.
- Perform all position adjustments and ensure they are securely fastened before placing the user in this product.
  - When placing the user in the equipment, for safety reasons, always secure the pelvic belt first. Chest and knee straps should then be attached afterwards.
  - When the product is stationary, make sure all wheels are locked and facing away from the base as this improves product stability.
  - Never adjust the overall height of the equipment while it is in use. Other minor position adjustments can be safely made when the user is in the equipment.
  - DO NOT use the equipment on a slope greater than five (5) degrees. Remember to lock all wheels.
  - This product contains plastic components and should therefore be kept away from all direct sources of heat, including open flames, cigarettes, electric and gas heaters.

## 6.2 SAFETY INSTRUCTIONS (continued)

- DO NOT place hot items on the tray at more than forty (40) degrees.
- Make sure to properly adjust the straps so that they fit snugly around the user and securely fasten the strap buckles to prevent slipping, falling, and serious injury during use.
- DO NOT leave the user unattended when they are getting on or off the product.
- Always check the functionality of the wheel brakes before using the product. If the brake is not working properly, the product should not be used.
- NEVER add additional weight other than that of the user to prevent the equipment from tipping over.
- NEVER use the product while in transit, in a vehicle.
- NEVER use the product on an escalator.
- NEVER descend stairs with the user in the product.
- NEVER move the product when the user is in it.
- The product can only be used by one user at a time.

## 7. REQUIRED TOOLS

Provided with the product:

- Allen key used for assembly of the product and adjustment of certain components (Fig. 7a).
- Tightening wrench facilitating the tightening of locking knobs (Fig. 7b).



Fig. 7a



Fig. 7b

## 8. UNPACKING AND ASSEMBLY

### 8.1 SAFETY TIPS

- Check that the packaging has not been damaged during transportation and that the product is in perfect condition.
- Carefully remove the packaging from the product.
- Make sure that the packaging material and small parts cannot fall into the hands of young children to avoid the risk of indigestion and choking.
- The product is delivered in several sections to be assembled. Please follow the assembly steps one by one to ensure the safety of the user during use.
- Handle the parts with care.
- Handle the tools safely.

### 8.2 LIST OF COMPONENTS TO ASSEMBLE

Before assembling the product, make sure that all parts are present (Fig. 8.2). For any damaged or missing parts, please contact Syntetik customer service (see section 18).

- (1) Base with wheels
- (2) Frame with knee stop and footplate
- (3) Stabilizer with thoracic and hip stops
- (4) Table
- Bagged Hardware:
  - (5) Quick Release Pin
  - (6) Allen Key
  - (7) Double Locking Pin
  - (8) Actuation Strap Cylinder
  - (9) Wrench for Locking Knob

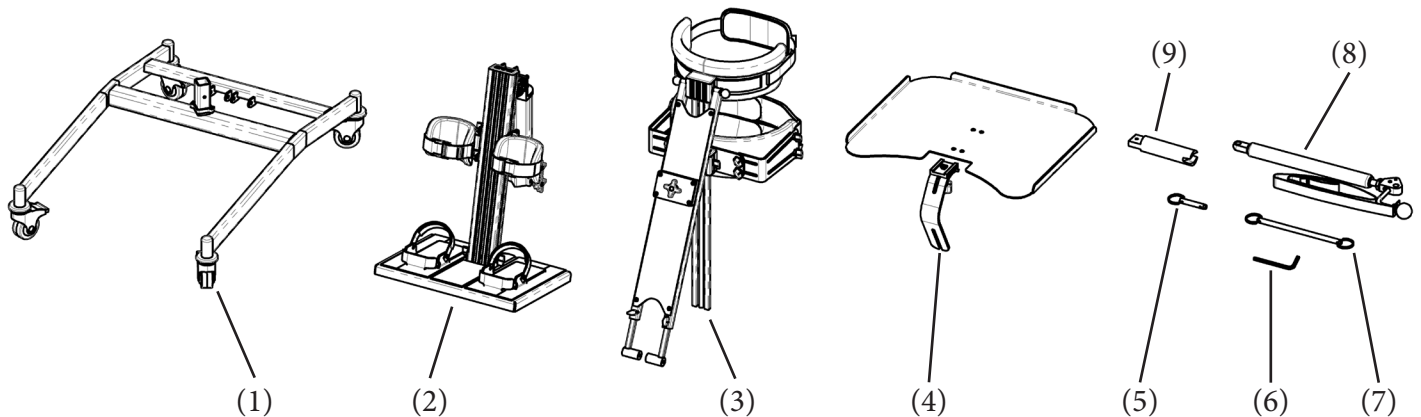

Fig. 8.2

## 8. UNPACKING AND ASSEMBLING

(continued)

### 8.3 ASSEMBLY PROCEDURES UPON RECEIPT OF PRODUCT

8.3.1 Place the base with wheels (1) on the ground and securely lock the brakes (A) of all four wheels (B) (Fig. 8.3.1a).

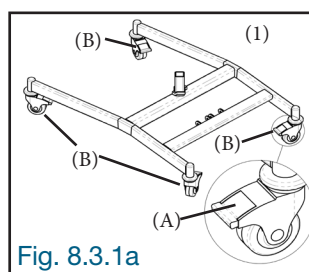

Fig. 8.3.1a

8.3.2 Loosen the knobs (A) on the frame (2) slightly (Fig. 8.3.2).

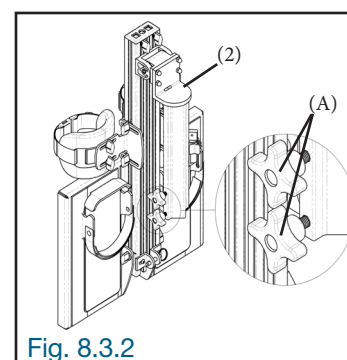

Fig. 8.3.2

8.3.2a Slide the profile (A) of the frame (2) onto the tube (B) of the base with wheels (1) (Fig. 8.3.2a).

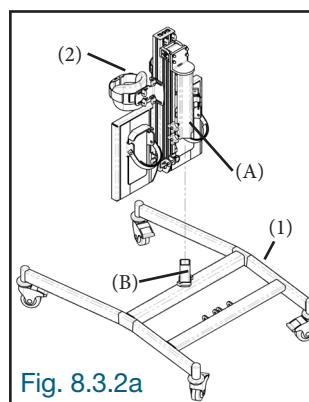

Fig. 8.3.2a

8.3.3 Tighten the knobs (A) on the frame (2) firmly (Fig. 8.3.3).

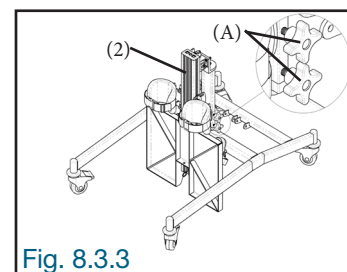

Fig. 8.3.3

8.3.4 Attach the cylinder (8) to the support (A) of the frame (2) by inserting the quick-release pin (5) (Fig. 8.3.4). Make sure that the lock (B) on the pin is completely disengaged on the other side of the support (A) so that it is securely locked.

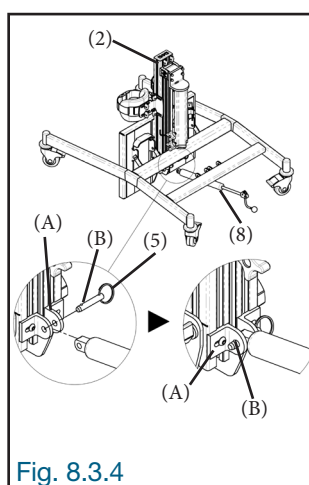

Fig. 8.3.4

8.3.5 On the stabilizer (3), move the hip stop (A) upwards to release the lower part of the rods (Fig. 8.3.5a). Loosen the two locking knobs (B) at the back of the chassis (2) slightly. Insert the rods (C) of the stabilizer (3) into the frame (2). Tighten the locking knobs (B) at the back of the frame (2) (Fig. 8.3.5b).

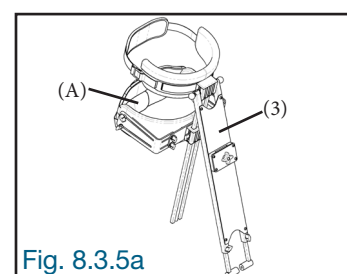

Fig. 8.3.5a

8.3.6 Remove the safety ring (A) from one end of the double-lock pin (7) (Fig. 8.3.6a). Insert the double-lock pin (7) to attach the stabilizer (3) and the cylinder (8) together to the base (1) (Fig. 8.3.6b). Reinsert the safety ring (A) removed earlier at the end of the double-lock pin (7) (Fig. 8.3.6c).

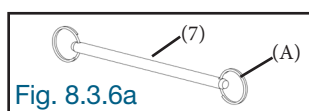

Fig. 8.3.6a

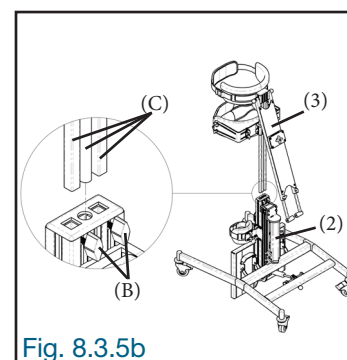

Fig. 8.3.5b

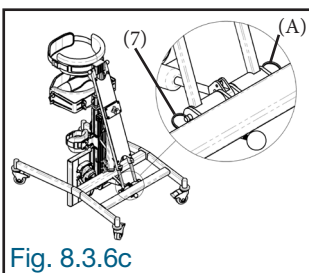

Fig. 8.3.6b

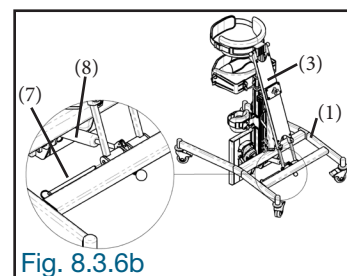

Fig. 8.3.6c



## 8. UNPACKING AND ASSEMBLY (continued)

### 8.3 ASSEMBLY PROCEDURES UPON RECEIPT OF PRODUCT (continued)

8.3.7 Pass the activation strap (A) of the jack under the central crossbar (B) of the base (1) and pull it up (Fig. 8.3.7a). Insert the activation strap (A) into the slot (C) (Fig. 8.3.7b). Pull the strap (A) so that the handle of the strap is completely disengaged from the slot (C) (Fig. 8.3.7c).

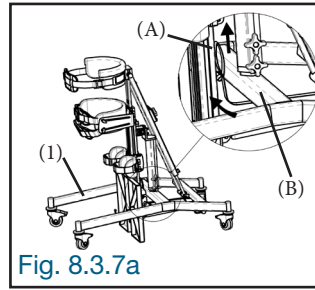

Fig. 8.3.7a

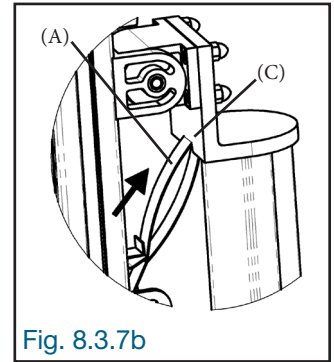

Fig. 8.3.7b

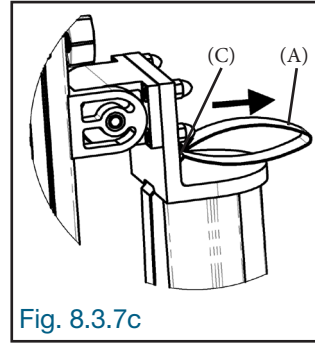

Fig. 8.3.7c

8.3.8 Remove the quick-release pin (A) from under the foot plate (B) (Fig. 8.3.8a). Loosen the locking knobs (C) slightly on each side of the foot plate (B) (Fig. 8.3.8b). Tilt the foot plate (B) downwards so that it is perpendicular to the frame (D). Ensure that it is aligned with the positioning mark (E) (Fig. 8.3.8c). Tighten the locking knobs (C) firmly on each side of the foot plate (B) (Fig. 8.3.8c).

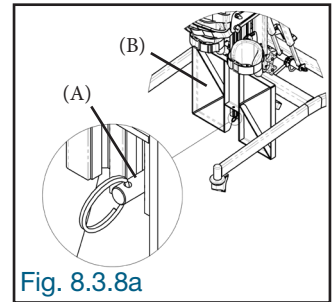

Fig. 8.3.8a

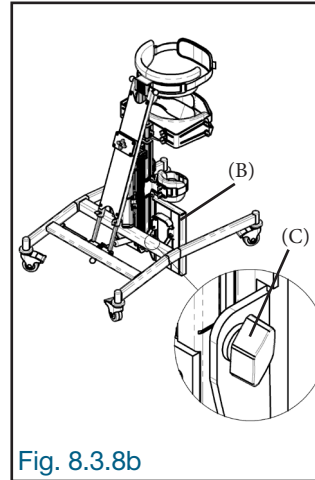

Fig. 8.3.8b

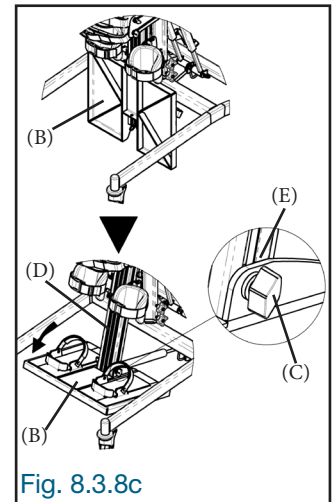

Fig. 8.3.8c

Insert the quick-release pin (A) under the foot plate (B), ensuring that the pin lock (F) is completely disengaged from the other side of the frame (D) so that it is properly locked (Fig. 8.3.8d).

8.3.9 Loosen the locking knob (A) slightly on the slide (C) of the stabilizer (3). Insert the support (B) of the table (4) into the slide (C), then tighten the locking knob (A) firmly to fix its position (Fig. 8.3.9).

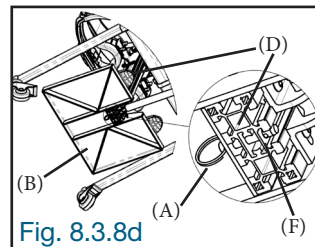

Fig. 8.3.8d

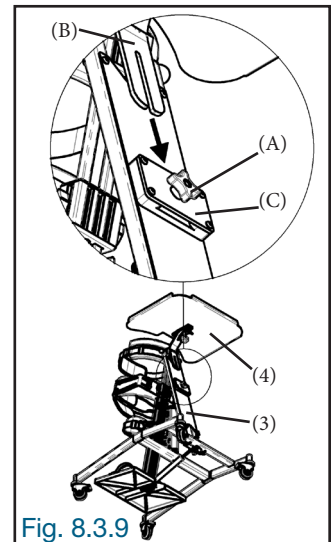

Fig. 8.3.9

8.3.10 Insert the Allen key (6) as well as the tightening key (9) into the tool holder (A) provided for this purpose (Fig. 8.3.10).

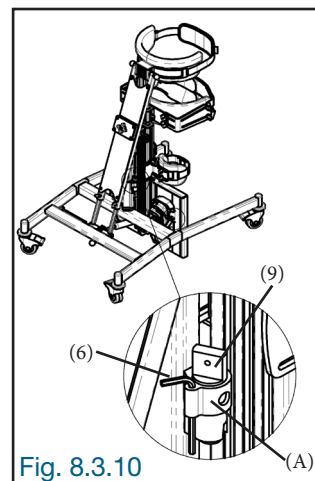

Fig. 8.3.10

## 9. USER TRANSFER PROCEDURES

9.1 Before proceeding with the user transfer in and out of the product, ensure that the device is:

- Positioned vertically and all wheels are securely locked.
- Placed on a smooth, flat, and level surface.

9.2 Once all the restraints (thoracic, hip, knee) have been cleared, gently transfer the user into the product. To facilitate the transfer, the user can hold onto the back of the hip restraint (A) (Fig. 9.2).

- DO NOT leave the user unattended while they are getting in or out of the product.
- The transfer of the user into and out of the product should be performed by a healthcare professional or a trained caregiver.
- Transfer techniques may differ from person to person, depending on their medical condition.

9.3 To securely maintain the user inside, adjust and buckle the straps in the following order (Fig. 9.3):

Hip restraint strap (A);

Thoracic restraint strap (B);

Knee restraint straps (C).

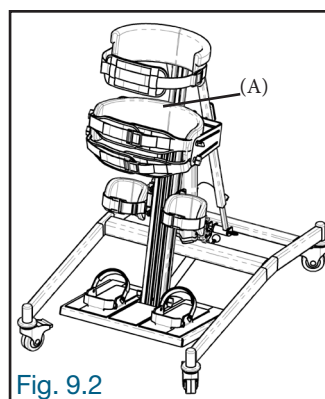

Fig. 9.2

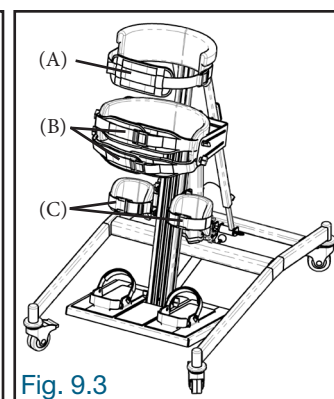

Fig. 9.3

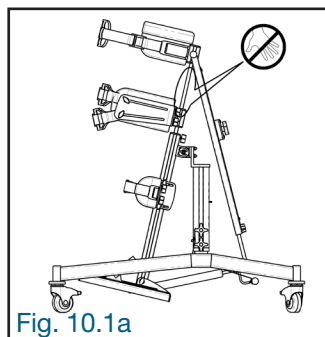

Fig. 10.1a

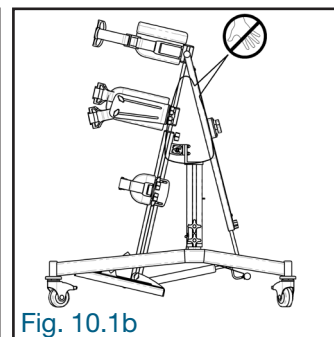

Fig. 10.1b

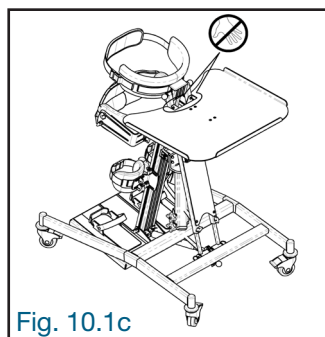

Fig. 10.1c

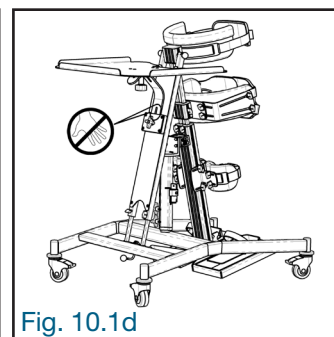

Fig. 10.1d

## 10. FREQUENT ADJUSTMENTS FOR DAILY USE

### 10.1 SAFETY TIPS

- When adjusting the height of the product by loosening the two locking knobs (A) at the back of the frame and the two locking knobs (B) at the bottom of the stabilizer platform, DO NOT place fingers or hands between the hip block (C) and the thoracic block (D) (Fig. 10.1a). Always hold the thoracic block (D) with one hand to prevent it from sliding down and trapping fingers and hand between the thoracic (D) and hip blocks (C).

- When adjusting the height of the product by loosening the two locking knobs (A) at the back of the frame and the two locking knobs (B) at the bottom of the stabilizer platform, DO NOT place fingers and hands between the hip block (C) and the stabilizer (D) as well as inside the triangular part (Fig. 10.1b).

- When adjusting the table horizontally, DO NOT place fingers and hands between the back of the table (A) and the stabilizer platform (B) (Fig. 10.1c).

- When adjusting the table vertically, DO NOT place fingers and hands between the groove of the table support (A) and the slide (B) of the stabilizer platform (Fig. 10.1d).

## 10.FREQUENT ADJUSTMENTS FOR DAILY USE (continued)

### 10.2 ADJUSTMENT PROCEDURES

Periodically check all settings on the device and ensure that they are always adjusted to the current user's body dimensions. If necessary, have a technician or specialized therapist adjust the settings.

**NOTE:** If you have difficulty reaching or tightening a locking knob (A) for adjustment, use the tightening tool (B) provided for this purpose (Fig. 10.2).

#### 10.2.1 WHEEL LOCKING

Each of the four wheels has a brake (A). Make sure that all four wheel brakes (B) are securely locked when the product is being used, adjusted, or stored (Fig. 10.2.1a).

#### 10.2.2 TABLE ADJUSTMENT

##### Front-to-back adjustment

Slightly loosen the locking knob (A) under the table and slide the table (B) forward or backward. At the desired position, tighten the locking knob (A) firmly to secure the table in place (Fig. 10.2.2a).

##### Tilt adjustment

Slightly loosen the locking knob (A) under the table and tilt the table (B) up or down on the table support (C). At the desired tilt angle, tighten the locking knob (A) firmly to secure the table in place (Fig. 10.2.2b).

##### Height adjustment

Slightly loosen the locking knob (A) on the slider (B) of the stabilizer (3) and slide the table support (C) up or down in the stabilizer slider. At the desired height, tighten the locking knob (A) on the slider firmly to secure the table in place (Fig. 10.2.2c).

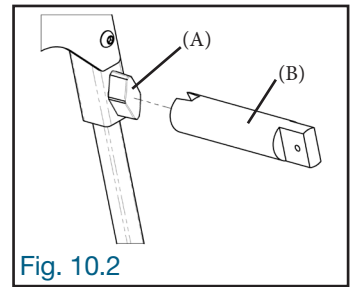

Fig. 10.2

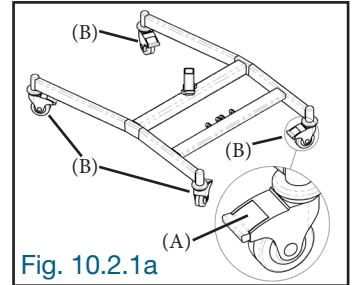

Fig. 10.2.1a

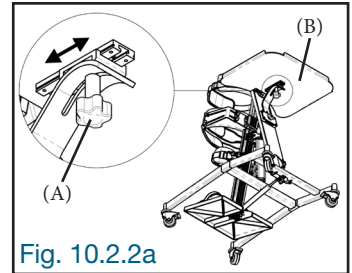

Fig. 10.2.2a

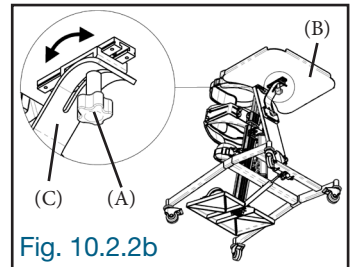

Fig. 10.2.2b

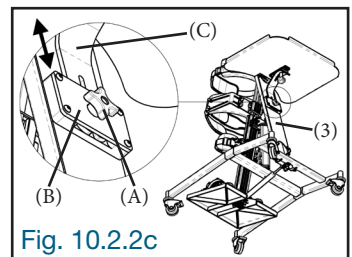

Fig. 10.2.2c

## 10. FREQUENT ADJUSTMENTS FOR DAILY USE (continued)

### 10.2.3 ADJUSTING THE HIP PAD

#### Height adjustment

Slightly loosen the locking knob (A) on each side of the hip pad block (B), adjust the hip pad (B) height on the frame (C), and firmly tighten the locking knobs (A) (Fig. 10.2.3a).

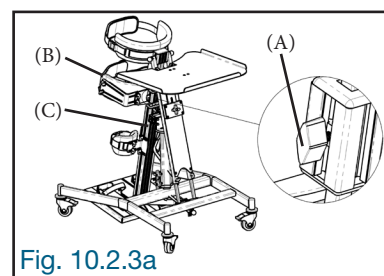

Fig. 10.2.3a

#### Width adjustment

Slightly loosen the locking knobs (A) at the back of the hip pad block (B). Slide and adjust the lateral pads (C) to the user's hips. Once adjusted, firmly tighten the locking knobs (A) (Fig. 10.2.3b).

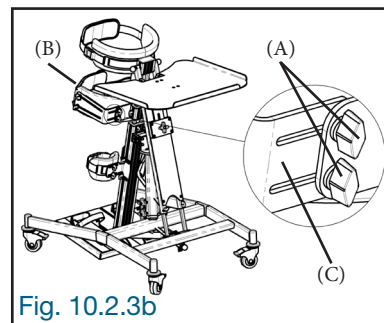

Fig. 10.2.3b

#### Hip belt adjustment

The hip pad belt (A) should be adjusted and tightened to the user's body to hold them in place. First, fold the half-belt (C) over the other half-belt with the hook-and-loop fastener (D) to cover at least half of the hook-and-loop fastener (E) of the half-belt (C). Second, adjust the length of the strap (F) by sliding it over the buckle (G) until the required length, and securely fasten the buckle (G). If necessary, slightly loosen the locking knobs (H) on each side of the hip pad block (B) to enlarge or tighten the belt (A) on the user's hips, and firmly tighten the locking knobs (H) (Fig. 10.2.3c).

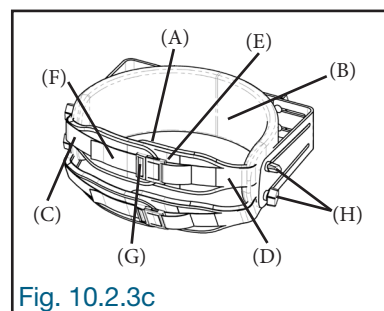

Fig. 10.2.3c

#### Support belt adjustment

The hip pad belt (A) should be adjusted to the user's buttocks to provide support. First, fold the half-belt (C) over the other half-belt with the hook-and-loop fastener (D) to cover at least half of the hook-and-loop fastener (E) of the half-belt (C). Second, adjust the length of the strap (F) by sliding it over the buckle (G) until the required length, and securely fasten the buckle (G). If necessary, slightly loosen the locking knobs (H) on each side of the hip pad block (B) to enlarge or tighten the belt (A) on the user's buttocks, and firmly tighten the locking knobs (H) (Fig.10.2.3e).

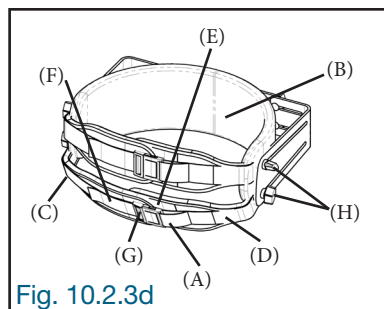

Fig. 10.2.3d

## 10.FREQUENT ADJUSTMENTS FOR DAILY USE (continued)

### 10.2.4 ADJUSTING THE THORACIC SUPPORT

#### Height adjustment

Slightly unscrew the locking knobs (A) at the back of the frame (B) as well as the locking knobs (C) at the bottom of the stabilizer (3), adjust the height of the thoracic rest (D), then firmly tighten the four previously unscrewed locking knobs (A) and (C) (Fig. 10.2.4a).

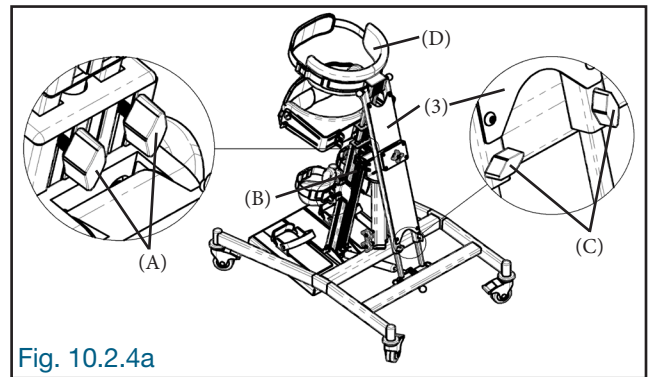

Fig. 10.2.4a

#### Strap adjustment

The strap (A) of the thoracic rest (B) should be adjusted and tightened to the user's body to hold it in place. To do this, adjust the length of the strap (A) by sliding it over the buckle (C) until the required length is achieved. Once the length is determined, securely attach the buckle (C). For better comfort, the cushion (D) should be centered on the user's back (Fig. 10.2.4b).

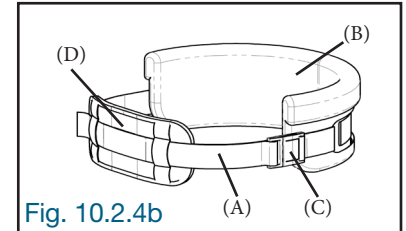

Fig. 10.2.4b

### 10.2.5 ADJUSTMENT OF KNEE PADS

#### Height adjustment

Loosen the locking knobs (A) of the knee stop support (B) and adjust the height of the knee stops (C). Then, tighten the locking knobs (A) firmly (Fig. 10.2.5a).

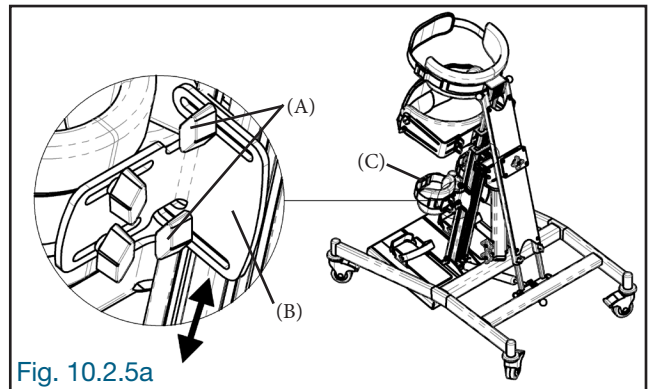

Fig. 10.2.5a

#### Width adjustment

Loosen the locking knobs (A) located at the back of the knee stop support (B). Slide the knee stop (C) to the required position and then tighten the locking knobs (A) firmly (Fig. 10.2.5b).

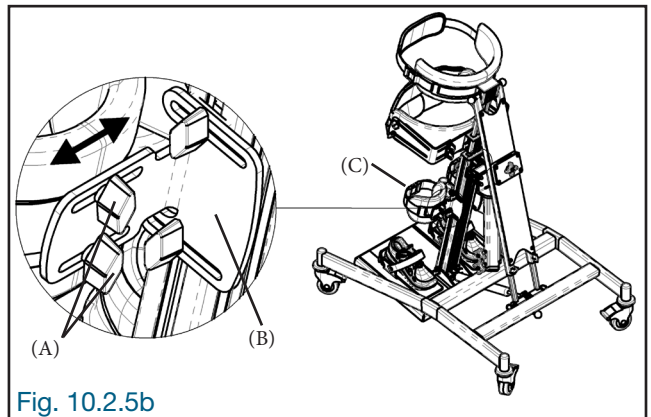

Fig. 10.2.5b

#### Strap adjustment

The strap (A) of the knee stop (B) must be adjusted and tightened to the user's body to hold it in place. To do this, adjust the length of the strap (A) by sliding it on the buckle (C) to the required length. Once the length is determined, attach the buckle (C) firmly (Fig. 10.2.5c).

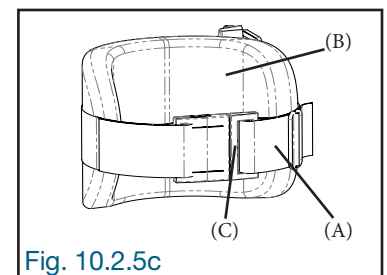

Fig. 10.2.5c

## 10. FREQUENTS ADJUSTMENTS FOR DAILY USE

### (continued)

#### 10.2.6 ADJUSTMENT OF THE TILT

When adjusting the tilt of the device, make sure that:

- The wheels are locked securely;
- You firmly hold the device with one hand while operating the actuation lever of the jack with the other hand;
- No part of the user's or caregiver's body can get caught during the tilt maneuver;
- All straps and other attachments are securely in place and adjusted properly;
- The device is at the appropriate distance from surrounding furniture to avoid potential collisions.

#### Tilting Forward

To adjust the tilt of the frame (A) forward, apply slight pressure with the tip of the foot on the lever (B) or pull slightly on the actuation strap (C), and the tilt will occur by itself. Release the pressure on the lever (B) when the desired tilt of the frame (A) is achieved (Fig. 10.2.6a).

#### Returning to Vertical

To return the device to the vertical position, apply slight pressure with the tip of the foot on the lever (B) or pull on the actuation strap (C), and push the frame (A) to return it to the vertical position. Release the pressure on the lever (B) once the frame (A) is in the vertical position (Fig. 10.2.6b).

#### 10.2.7 FOOTPLATE ADJUSTMENT

Depending on its current position, it is possible to raise or lower the footplate (A) by one and a half inches.

Remove the quick-release pin (B) under the footplate (A) (Fig. 10.2.7a). Loosen the knobs (C) slightly on each side of the footplate (A) (Fig. 10.2.7b).

Slide the footplate (A) on the frame (D) to align the hole (E) in the footplate with the desired hole (F) in the frame (Fig. 12.2.7c). Insert the quick-release pin (B) under the footplate (A). Make sure the lock (G) of the pin (B) is completely disengaged from the other side of the frame (D) so that it is securely locked (Fig. 10.2.7a).

Tighten the knobs (C) on each side of the footplate (A) (Fig. 10.2.7b).

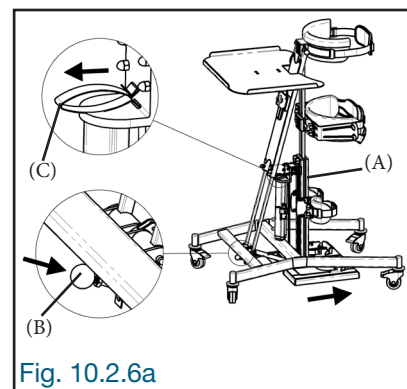

Fig. 10.2.6a

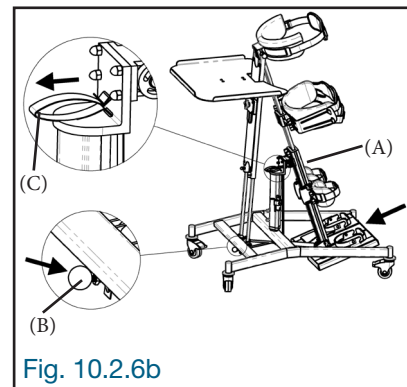

Fig. 10.2.6b

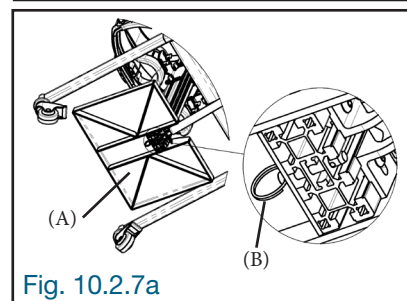

Fig. 10.2.7a

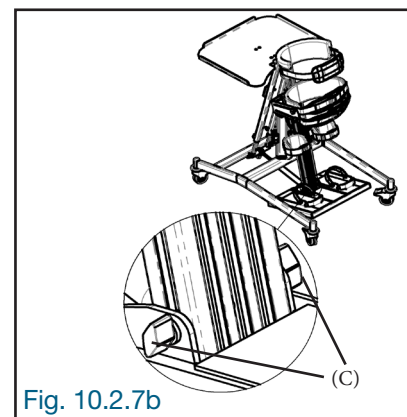

Fig. 10.2.7b

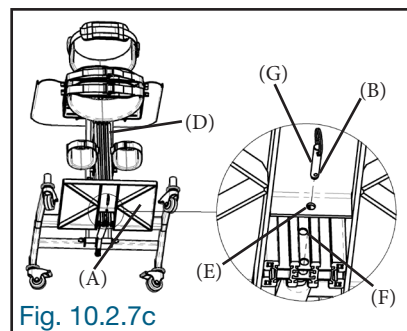

Fig. 10.2.7c

## 10. FREQUENT ADJUSTMENTS FOR DAILY USE (continued)

### 10.2.8 FOOTREST

The footrests (A) are attached with self-gripping straps (B), allowing them to be moved to the ideal position for the user. Once positioned, detach the self-gripping strap (C) and slide the foot inside the footrest (A). Secure the foot using the self-gripping strap (C) by folding it over the top of the foot near the ankle (Fig. 10.2.8).

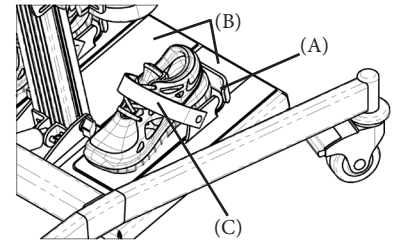

Fig. 10.2.8

## 11. CLEANING AND MAINTENANCE

### 11.1 CLEANING

When cleaning the product, we recommend using only warm water and a non-abrasive detergent. Never use organic solvents, bleach, or dry cleaning fluids.

### 11.2 PADDING AND FABRICS

- It is normal for the fabric to fade as a result of prolonged exposure to sunlight and frequent washing. It may also show signs of wear after long-term use, even with normal use.
- Padding and fabrics can be hand-cleaned in place. When cleaning, we recommend using only warm water and a non-abrasive detergent.
- The best cleaning method is the “wipe and dry” technique.
- Stains should be removed as quickly as possible with an absorbent cloth, towel, or sponge. Mild soap and a sponge with warm water are effective for ordinary dirt and minor spills. Be careful not to over-wet the fabric as this could cause the stain to spread.
- Antiseptic cleaning agents can be used on the most stubborn stains. These may require a solvent such as isopropyl alcohol or mineral spirits. Half a cup of bleach in 5 liters of water can also be used as a disinfectant.
- Always make sure the product is dry before use.
- Padded components such as chest, hip, and knee stops are made of a fabric cover that can be removed for machine washing and air drying.
- To keep the Velcro straps operational, clean them from time to time with a brush. When washing components with Velcro straps, always close the straps or cover them.

### 11.3 METAL AND PLASTIC COMPONENTS

- Soap and water or an antibacterial spray can be used for daily cleaning.
- For deep cleaning, low-pressure steam cleaning can be used.
- Do not use solvents to clean plastic, wood, or metal components.
- Make sure the product is dry before use.

## 12. DAILY INSPECTION

Synetik Group Inc. recommends that a daily visual inspection be performed by a therapist, parent, or caregiver before each use to ensure safe use of the device. At each visual inspection, you must check and ensure that:

- There is no breakage, tearing, or missing parts. In case of doubt, immediately stop use and contact customer service;
- All protective coatings (cover) and straps show no signs of wear and tear;
- The strap buckles are attached correctly and not damaged;
- The wheels rotate, pivot freely, and lock securely;
- The footplate is securely attached to the frame;
- All locking knobs are in place and tightly secured.

## **13. ANNUAL INSPECTION, MAINTENANCE, AND SPARE PARTS**

### **13.1 ANNUAL INSPECTION**

Synetik Group Inc. recommends that the device be inspected annually. Make sure to inspect the functioning and condition of the components (breakage, cracking, wear affecting the structural integrity or safe operation of the product).

List of components to check:

- Base/Wheels/Brakes
- Mast/Hinge
- Stabilizer/Rods
- Frame/Rods
- Table
- Foot Plate
- Jack
- Padding
- Straps/Buckles
- Cushions
- Plastic parts
- Metal parts
- Locking knobs/pins
- Nuts/bolts

### **13.2 MAINTENANCE AND REPAIR**

Maintenance and repairs of the product must be carried out by qualified personnel only. The user of this product must ensure that the prescribed checks and maintenance are carried out regularly and in a timely manner. If damage is evident, the user must actively inform and have the damage repaired immediately by qualified personnel.

### **13.3 SPARE PARTS**

- Only original equipment manufacturer spare parts may be used for repairs.
- If a part is missing or damaged, immediately stop using the product and contact an authorized representative of Synetik Group Inc. Replacement parts can be ordered separately through an authorized agent of Synetik Group Inc. or our customer service.
- The disassembly and assembly of spare parts must be performed only by qualified personnel. If a return is necessary, make sure that the product is safely packaged for transport.

## **14. MAINTENANCE SERVICE**

Maintenance of all Synetik products should only be carried out by technically competent persons who have been trained in the use of the product. In Canada, please contact the Synetik Service Center at +1 450 752-8818 and our customer service will be happy to assist you with your maintenance needs.



## **15. STORAGE**

- Store the product in a safe and dry place when not in use.
- DO NOT place heavy objects on the table during storage.
- If the product is wet or damp, wipe the metal and plastic parts and let them air dry before storing.

## **16. REUSE BY A NEW USER**

This product can be reused by a new user. Before passing it on to the next user, the product must always be carefully cleaned and disinfected. The condition and wear and tear of the product must be checked by trained personnel. Any damage must be corrected to ensure safe and continued use of the product by the new user. The user instructions are part of the product and must be passed on to the new user. The product settings must be adjusted to the body dimensions of the next user. If necessary, have the settings adjusted by a specialized technician or therapist.

## 17. TECHNICAL SPECIFICATIONS

	SKY Multi-positioning Standing prone frame		
	SIZE 1	SIZE 2	SIZE 3
<b>User size and weight</b>			
<b>User's height (floor to axilla)</b>	50.8cm-81.3cm (20"-32")	68.6cm-104.1cm (27"-41")	86.4cm-127cm (34"-48")
<b>User's weight</b>	45kg (100lbs)	72kg (160lbs)	72kg (160lbs)
<b>Measurement from floor to knees</b>	10.1cm-30.5cm (4"-12")	10.1cm-40.6cm (4"-16")	10.1cm-50.8cm (4"-20")
<b>Measurement from floor to hips</b>	38.1cm-63.5cm (15"-25")	49.5cm-78.7cm (19.5"-31")	63.5cm-96.5cm (25.5"-38")
<b>Chest</b>			
<b>Maximum chest circumference</b>	73.7cm (29")	83.8cm (33")	101.6cm (40")
<b>Chest width</b>	12.7cm-22.9cm (5"-9")	17.8cm-27.9cm (7"-11")	22.9cm-33cm (9"-13")
<b>Chest support height</b>	10.1cm (4")	10.1cm (4")	12.7cm (5")
<b>Hip</b>			
<b>Maximum hip circumference</b>	73.7cm (29")	83.8cm (33")	101.6cm (40")
<b>Hip width</b>	12.7cm-22.9cm (5"-9")	17.8cm-27.9cm (7"-11")	22.9cm-33cm (9"-13")
<b>Hip support height</b>	10.1cm (4")	10.1cm (4")	12.7cm (5")
<b>Base</b>			
<b>Base width</b>	50.8cm (20")	61cm (24")	61cm (24")
<b>Base length</b>	76.2cm (30")	91.4cm (36")	91.4cm (36")
<b>Table</b>			
<b>Inner table width</b>	50.8cm (20")	61cm (24")	61cm (24")
<b>Inner table length</b>	40.6cm (16")	50.8cm (20")	50.8cm (20")
<b>Table tilt angle range</b>	0 to 25 degrees	0 to 25 degrees	0 to 25 degrees
<b>Measurement from table to axilla</b>	3.3cm-9.9cm (1.3"-3.9")	7.6cm-14.2cm (3"-5.6")	10.9cm-18.3cm (4.3"-7.2")
<b>Knee</b>			
<b>Maximum knee circumference</b>	33cm (13")	38cm (15")	43.2cm (17")
<b>Knee width</b>	3.8cm-8.9cm (1.5"-3.5")	6.4cm-10.1cm (2.5"-4")	7.6cm-14cm (3"-5.5")
<b>Knee Support height</b>	10.1cm (4")	10.1cm (4")	10.2cm (4.5")
<b>Foot Plate</b>			
<b>Foot plate (Width X Length)</b>	35.6cm x 30.5cm (14" x 12")	45.7cm x 35.6cm (18" x 14")	45.7cm x 35.6cm (18" x 14")
<b>Foot plate support (Width X Length)</b>	8.9cm x 19.1cm (3.5" x 7.5")	10.1cm x 22.9cm (4" x 9.5")	12.1cm x 30.5cm (4.75" x 12")
<b>Other</b>			
<b>Frame tilt range</b>	0 to 24 degrees	0 to 26 degrees	0 to 19 degrees
<b>Measurement from floor to foot plate</b>	10.1cm (4.5")	7.6cm (3")	7.6cm (3")
<b>Unit weight with table</b>	17kg (38lbs)	22kg (48lbs)	24kg (53lbs)
<b>Overall width</b>	50.8cm (20")	61cm (24")	61cm (24")
<b>Overall length</b>	76.2cm (30")	91.4cm (36")	91.4cm (36")
<b>User height (from floor to top of head)</b>	71.1cm-119.4cm (28"-47")	94cm-150cm (37"-59")	121.9cm-182.9cm (48"-72")

## 18. CONTACT US

Synetik Group Inc.

1242 Lanaudière, Joliette, Canada, J6E 3P1

+1 450 752-8818

info@synetikergocare.com