

TRYSIGHT



SPECIAL NEEDS
COMPUTERS 
1-877-724-4922

MERCURY 13/PORTABLE CCTV with SPEECH
User Guide / Version 1.0

TABLE OF CONTENTS

Introduction to Mercury 13.....	1
Safety and Care.....	2
What's Included.....	3
Using the Mercury 13.....	4-8
Powering On and Charging.....	4
Ejecting and Inserting the Tablet.....	5
Quick On/Off.....	6
LED Light.....	7
Keyboard.....	8
Reference Guide.....	9-10
Locations.....	9
LED Light & Camera.....	10
Starting the Software.....	11
Top Menu Bar.....	12
Top Menu Bar.....	13
Magnifying.....	14
Changing Colors/.....	15
Capturing and Saving Pictures.....	16
Capturing and Saving Videos.....	17
Reading Text.....	18-19
To Read	18
When Reading.....	19
Distance Viewing(Optional).....	20-27
Camera Placement.....	20
Distance Viewing Controls.....	21-22
Dual Monitor.....	23-27

TABLE OF CONTENTS

Settings.....	28-32
General Options.....	29
Speech Options.....	30
Reading Options.....	31-32
Power Off	33-34
Warranty Conditions.....	35
Contact Us.....	36
Technical Specifications.....	37

INTRODUCTION TO MERCURY 13

Congratulations on your purchase of the ***Mercury 13!*** Easy and comfortable reading has been brought closer and more accessible by this device made by Trysight.

Mercury 13 is an advanced tablet based magnifier with highly accurate reading capabilities allowing the user to listen to printed material in a clear natural sounding voice.

The Mercury 13 has been designed with the low vision user in mind. It doubles as a magnification system and a Windows laptop by using a large print Bluetooth keyboard. We are excited for you, our valued customers, as you enjoy the possibilities we have imagined!

SAFETY AND CARE

Do not expose the *Mercury 13* to extreme or rapid changes in temperature or humidity. Do not place *Mercury 13* near a radiator or heater, or where it will be exposed to direct sunlight. These conditions may damage electronics or optics of the *Mercury 13*.

Do not place this system on an unstable surface. It may fall, causing serious damage to the unit or injuries to the user.

WHAT'S INCLUDED



Mercury 13 unit should come with these items:

- 1X - Laptop travel case
- 1X - Mercury 13 tablet with stand
- 1x - Second Monitor (optional)
- 1X - Distance camera (optional)
- 1X - Bluetooth keyboard with trackpad
- 1X - Charger
- 1X - User Manual

USING THE MERCURY 13

Powering On and Charging

Mercury 13 comes with a stand which holds the tablet. There is a handle on the stand to carry the unit. Simply open the stand and this will unveil the tablet. The tablet screen can be tilted to a comfortable angle.

The charging cable gets connected on the left side of the tablet.

The power button is located on the bottom left side of the tablet. Hold down the power button for 2 seconds to start the device.

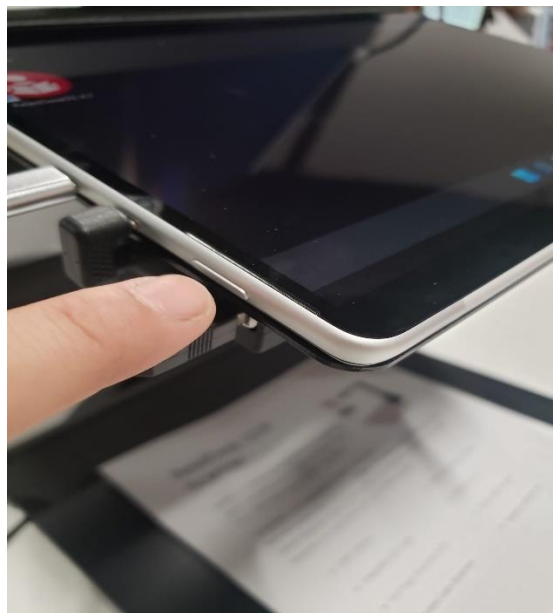
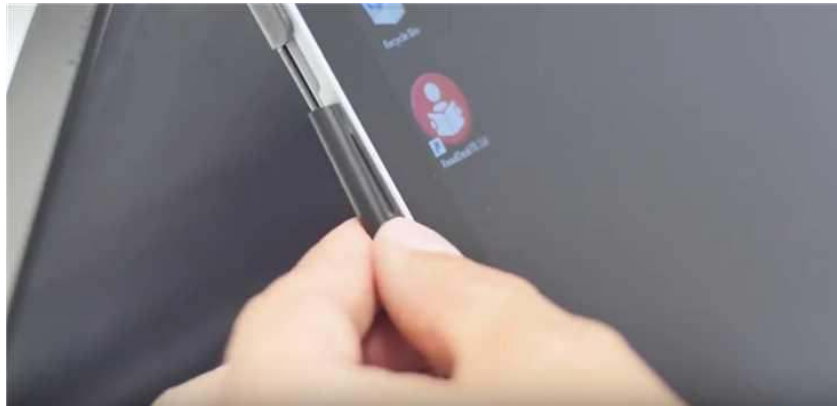

USING THE MERCURY 13

Ejecting and Inserting the Tablet

To eject the Microsoft Surface tablet from its stand, slightly press down the bracket on the top right plate of the stand and gently slide the tablet out by pushing it to the right. While inserting the tablet back onto the stand, ensure that the power button is on the left side.



USING THE MERCURY 13

Quick On and Off

To enable quick on/off functionality, the unit can go into "Sleep" mode. The unit can wake up instantly from sleep mode in 2 seconds. However, Sleep mode uses a small amount of battery as the unit is not completely turned off. After about 2 weeks in sleep mode, the battery will drain out and will need recharging even if you don't use the unit. To put the unit to sleep, tap the Power button quickly (Don't hold it down). To wake it up, tap the powerbutton again.

Use as a Windows Machine

The unit is a full-fledged Windows machine and can be used as such. All Windows applications will run normally and the machine can be used as your laptop. If you remove the tablet from the stand, a hinge on the back of the tablet allows a plate to come out of the body and hold the screen upright at an angle of your choice.



USING THE MERCURY 13

LED Light

The LED flash light is built separately in to the stand to provide better image quality. It is located behind the tablet.

- LED Light Switch

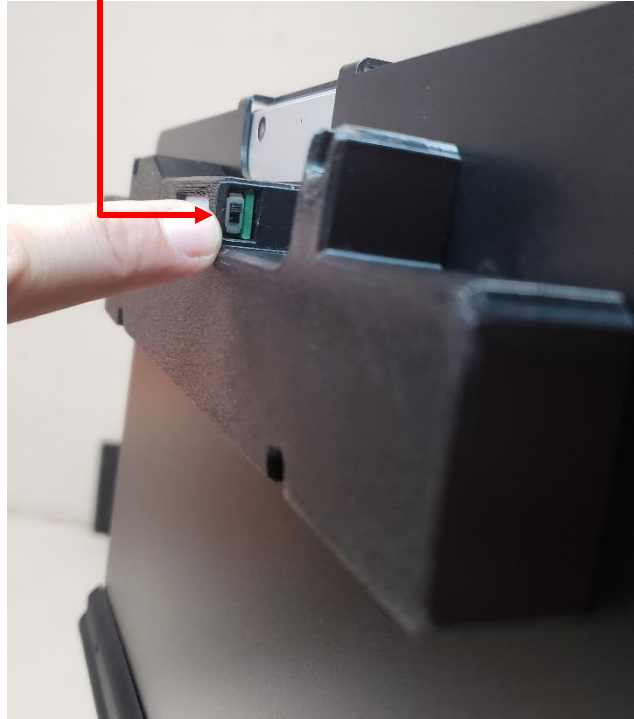

- LED/HUB Connector Cable



USING THE MERCURY 13

Keyboard with Trackpad

The keyboard with trackpad is connected by Bluetooth. For personalization, go to settings and under Bluetooth devices, keyboard can be removed and paired to the tablet.

To pair the keyboard, turn it on using the power button on the keyboard, then hold down “Fn” + “C” and a blue light will blink on the keyboard indicating it is ready to pair. Then go into Windows Bluetooth settings and add a new Bluetooth device. Search for a device called “TrySight Keyboard” and click on it to complete pairing.



REFERENCE GUIDE

Device Overview

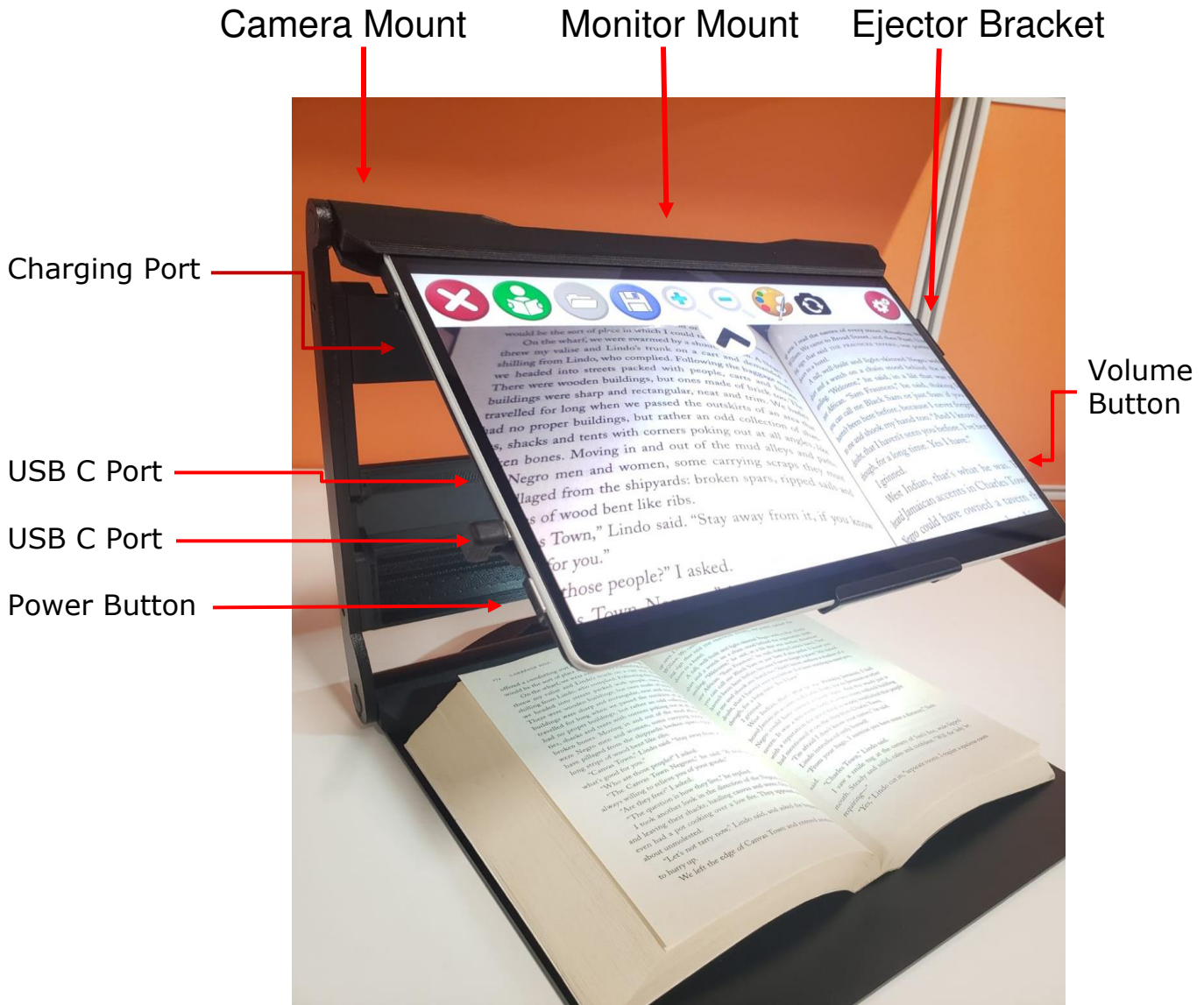

REFERENCE GUIDE

Device Overview LED Light, USB Port and Camera

LED Light Port

Surface Camera

LED Switch



Eject Bracket

USB Port



STARTING THE SOFTWARE

Starting the Software

To start the software, double click the ReadDesk icon on desktop. The software starts in Live Magnification mode. Place the paper or text you want to magnify or read under the camera.

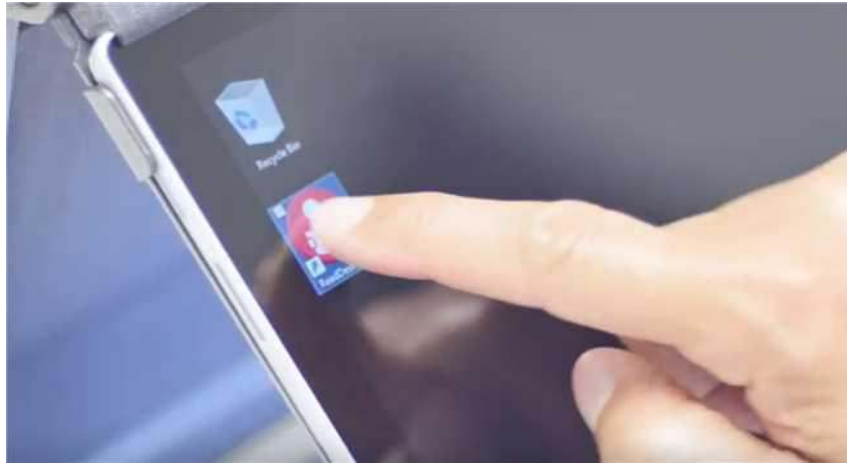

Focusing Text

To focus text, simply tap the screen once. A white square will appear on the screen along with an audible sound. During this time, other actions are disabled. Once focusing is complete, the square will change color to green and a double beep will sound.

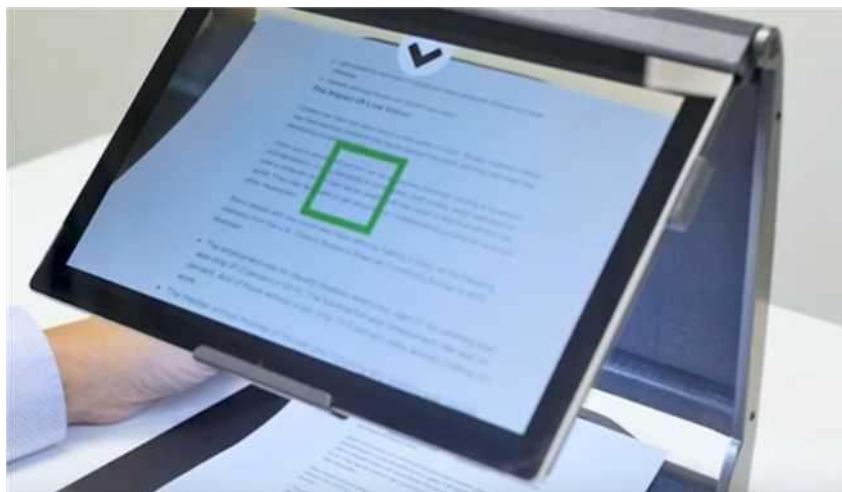

TOP MENU BAR

The software starts in Live Magnification mode. Clicking or tapping a small arrow on the top allows the opening of a menu bar which has various magnification options as shown in images below.

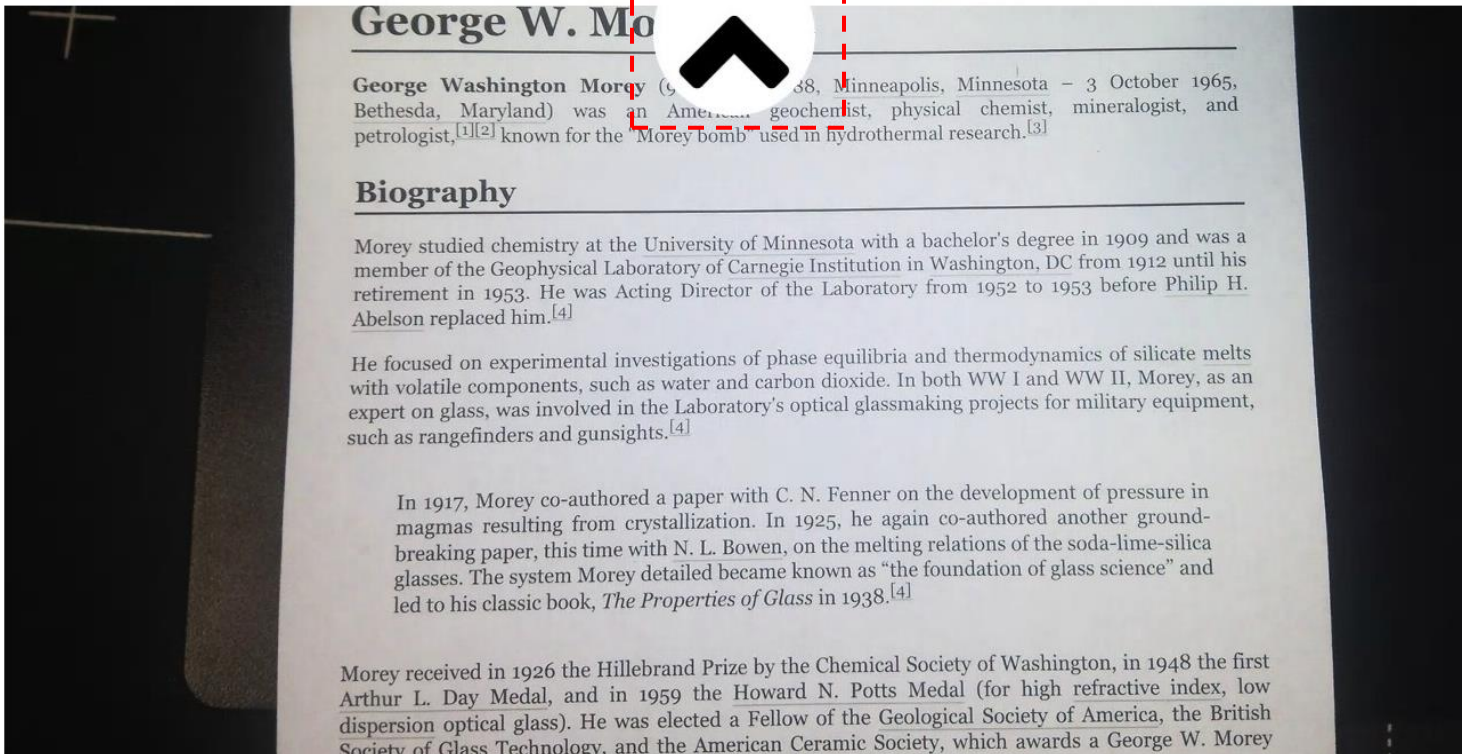
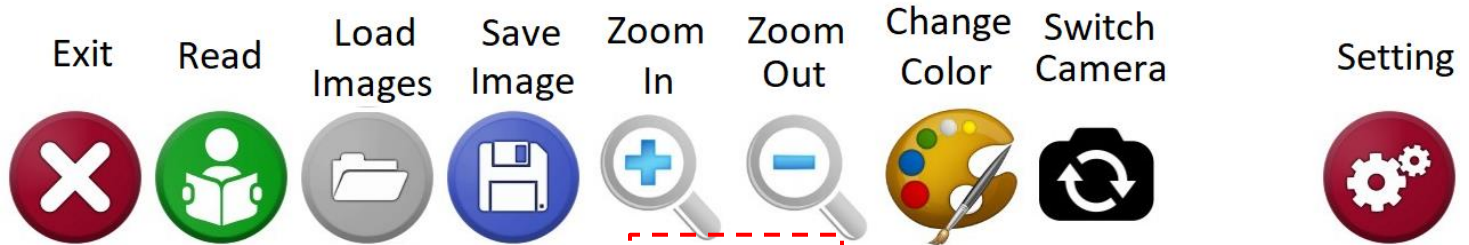

TOP MENU BAR

When the distance camera is plugged in, the top menu bar changes the Switch Camera icon to a Distance View icon as shown below

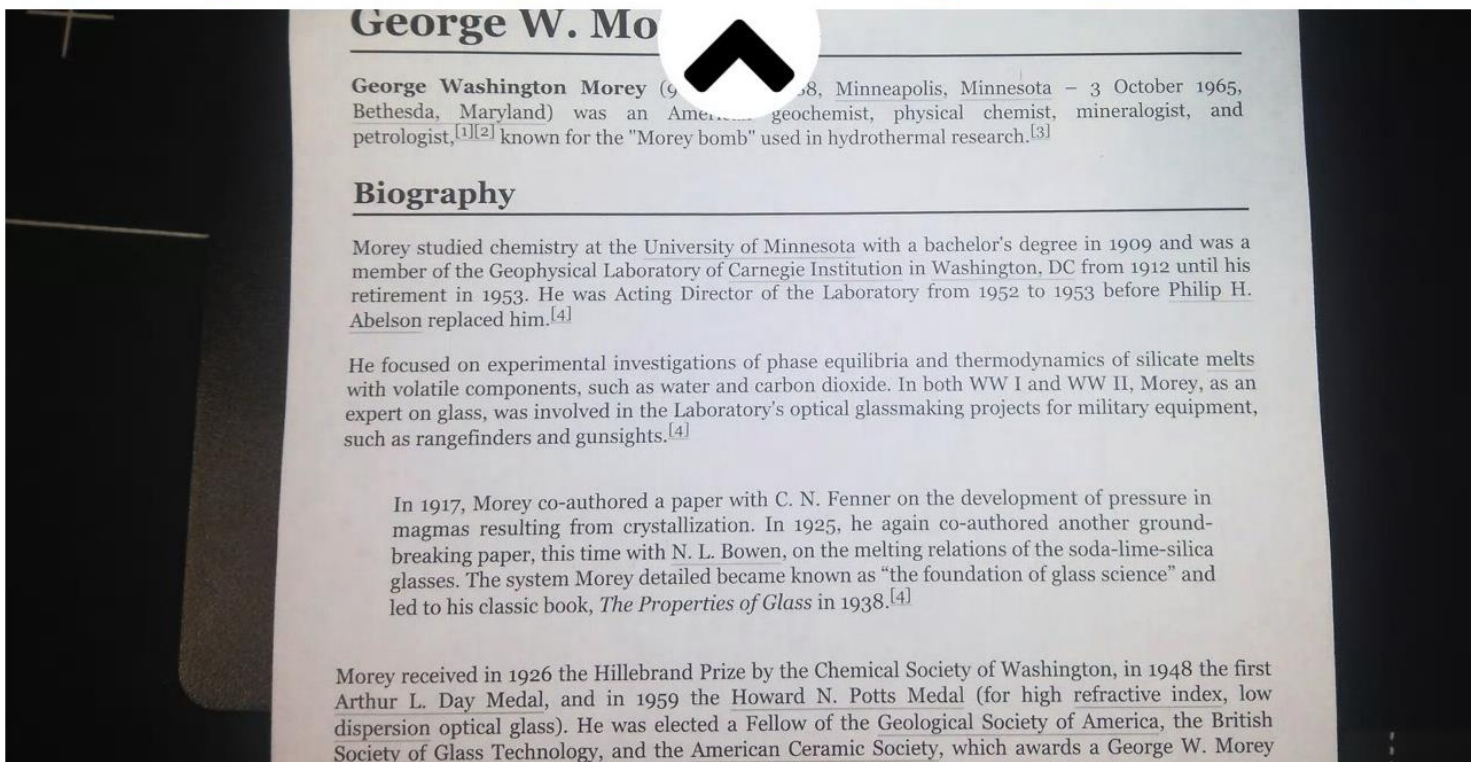
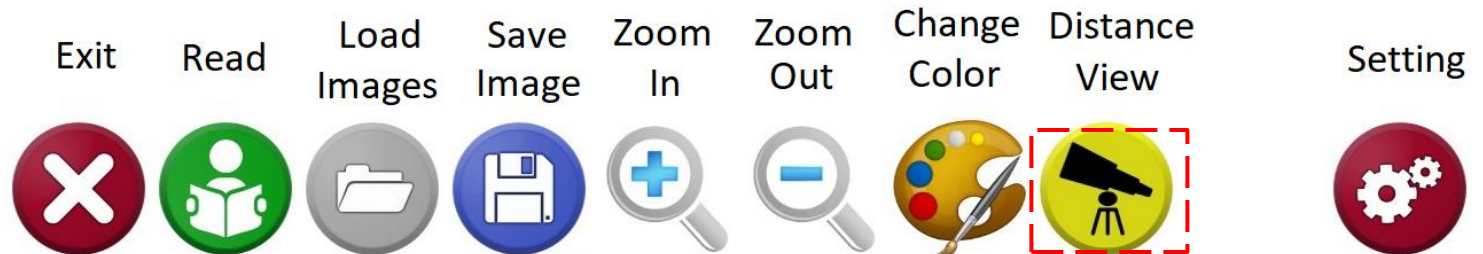

MAGNIFYING (ZOOM IN AND OUT)

Zooming In and Out

Three ways to Zoom In and Out:

1. Using the menu on top of the screen. Click on the down tab to make the menu appear (picture 14.1). Choosing the magnifying glass with plus (+) sign will allow you to zoom in and choosing the magnifying glass with minus (-) sign will make the screen zoom out.

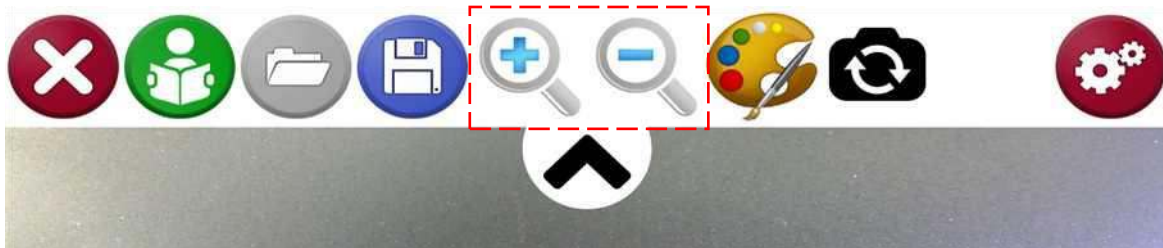

14.1 (top menu to zoom in and out)

2. Using 'Two-finger Pinch Zoom'. Pinch apart to zoom in and pinch together to zoom out.



3. Using the + and – Keys on the keyboard. Press the + or – keys on the keyboard to zoom in/out.

CHANGING COLOR

You can change to your preferred color by tapping on the paint brush icon on the menu or pressing the letter 'C' on the keyboard.

Options for contrast are as follows: Original (color), High Contrast (color), Black on White, White on Black, Black on Yellow, Yellow on Black, Black on Green, Green on Black, Yellow on Blue, Blue on Yellow and Grayscale.

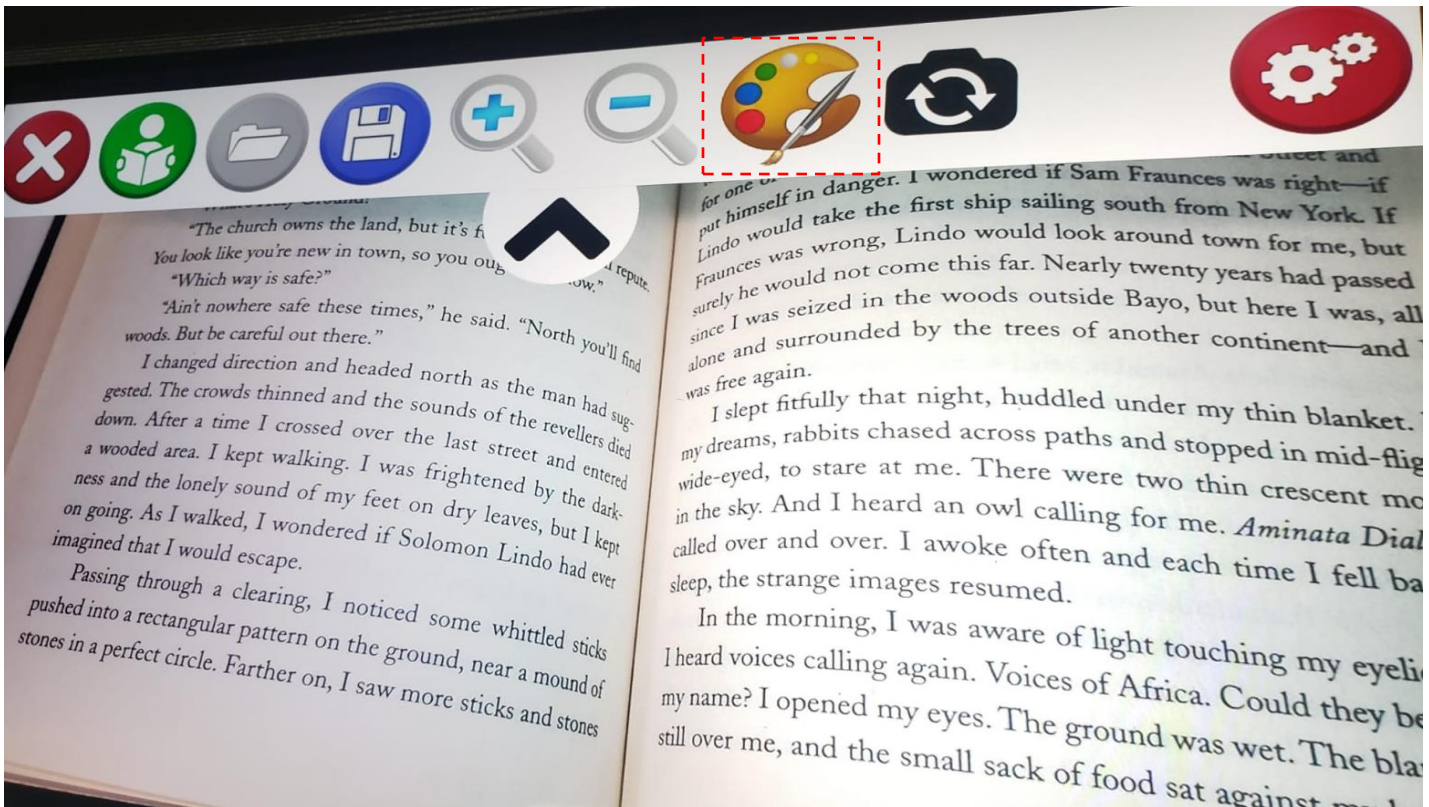

CAPTURING AND SAVING PHOTOS

Capture & Save Pictures

To capture and save a picture, move the stand to an almost horizontal position, with the tablet almost straight down. Press the save icon (Floppy disk icon) and select the camera icon. Once the picture is taken, tilt the screen back to a comfortable position.

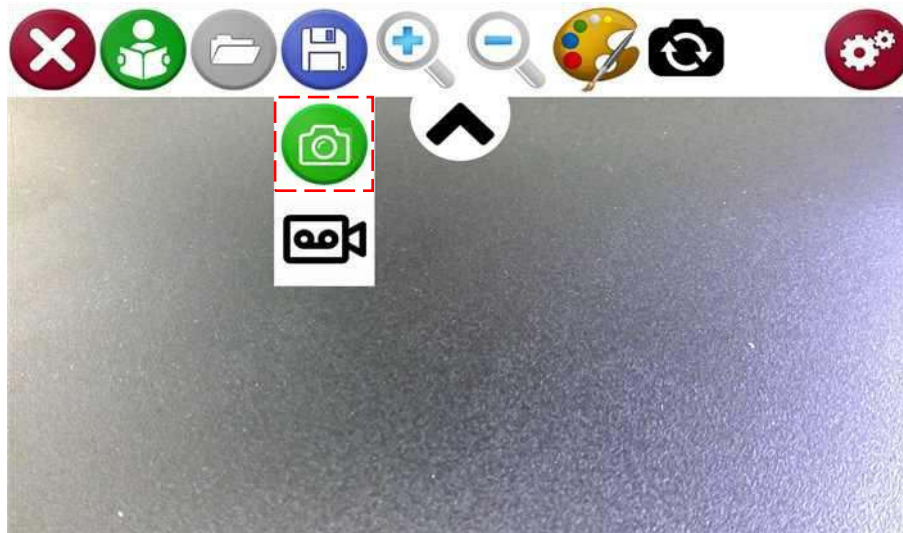

Open a Picture

To open a saved picture, select the load picture icon. This will open a list of folders ordered by date with their respective images. Choose a folder to access the images within it.

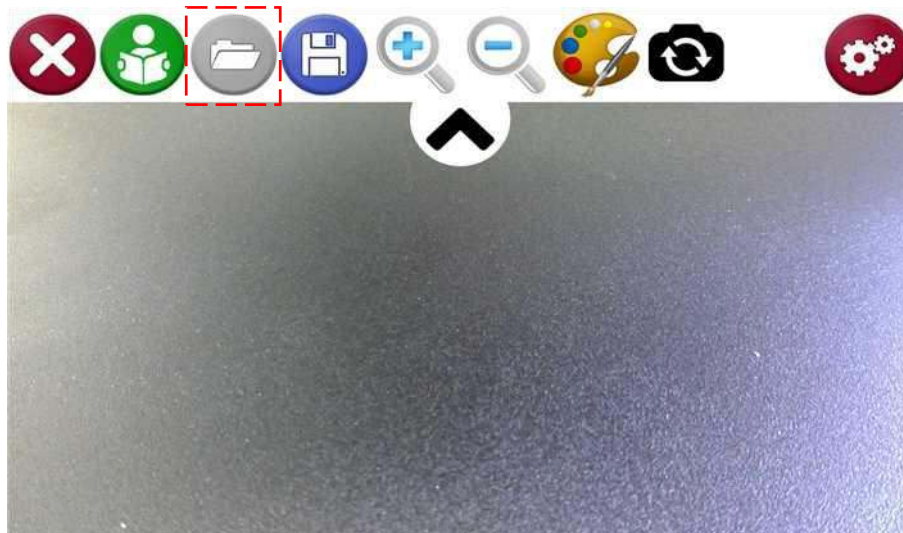

CAPTURING AND SAVING VIDEOS

Capture & Save Videos:

To capture and save a video of what's being shown on the screen, press the save icon and select the Video icon. When video is recording, a red circle will blink in the corner of the screen. To stop recording, press the save icon again and press the Stop icon which will appear in same place as the video icon earlier.

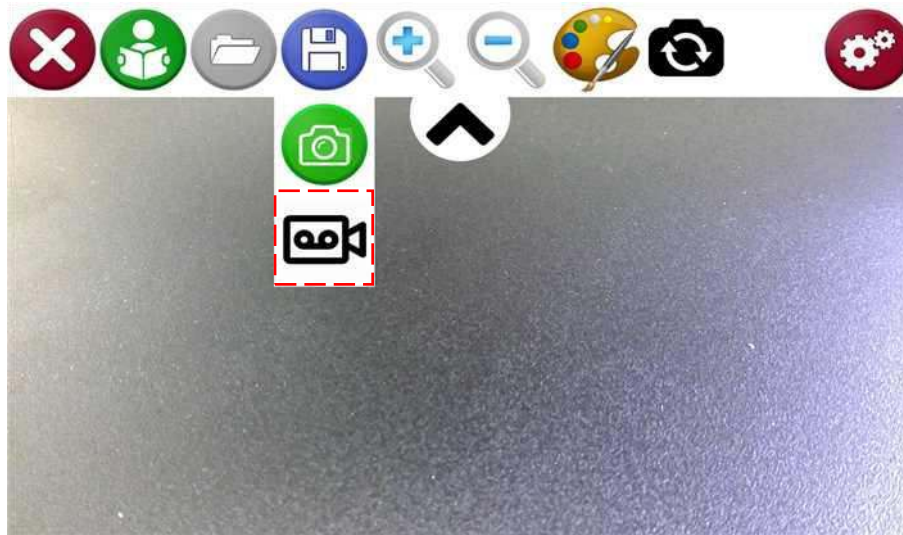

Opening a Video

Videos that were taken using the Mercury 13 are automatically saved on video folder of the device. Simply open This PC -> Videos -> Read Desk folder

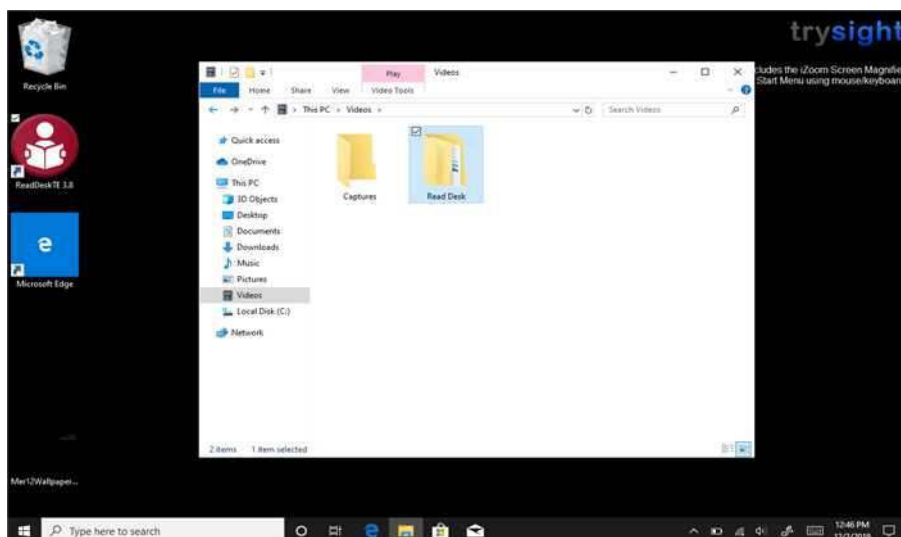

READING TEXT

To Read:

To read a full A4 document, raise the stand and position the tablet to an almost horizontal position with the camera pointing straight down (as shown below). Press the read icon. You may then reposition the stand to a comfortable viewing angle and listen to the document.



READING TEXT

When Reading:

By default, reading will start upon completion of processing. To pause, tap anywhere on the screen with one (1) finger, then tap again to resume.

Zoom in and out in reading mode using the same two-finger pinch gesture as in magnification mode (see page 14, item 2).

Save the captured image by clicking the green camera icon. Save the captured text as a TXT document by clicking the disc icon on the bottom right. The file will be saved in My Documents\Read Desk Text\ with the respective date/time the image was saved as the filename.

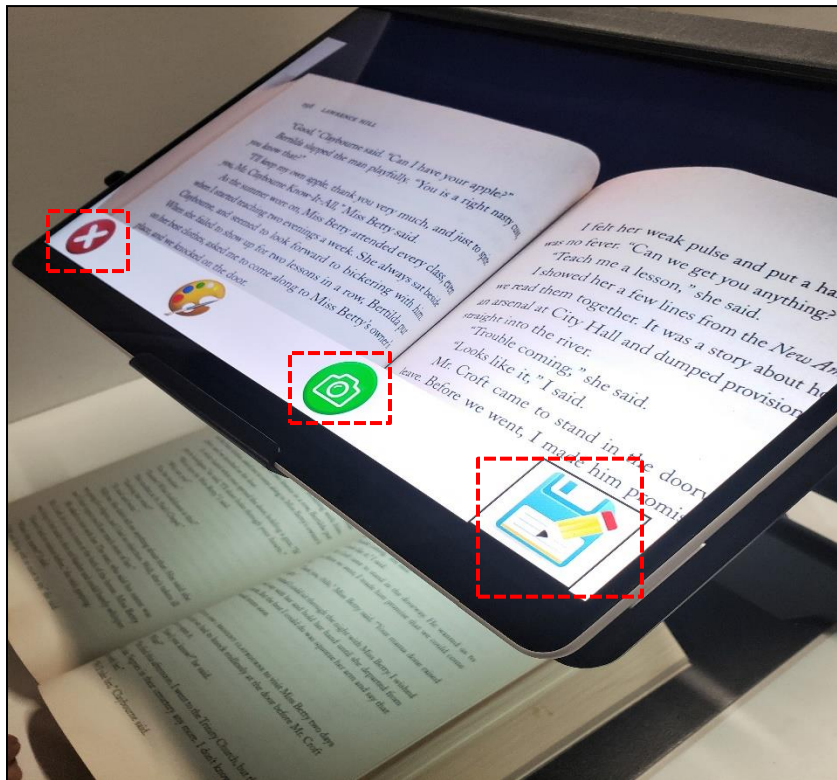

To read something else, tap the "X" on the topleft or press escape.

DISTANCE VIEWING

Camera Placement

Insert the camera into the slot on the top left corner of the stand
Connect the camera to the tablet using the provided USB. In approximately 10 seconds, the "Distance View Camera" will be activated and the icon will appear on the menu.



Camera Port

DISTANCE VIEWING

Distance Viewing Controls

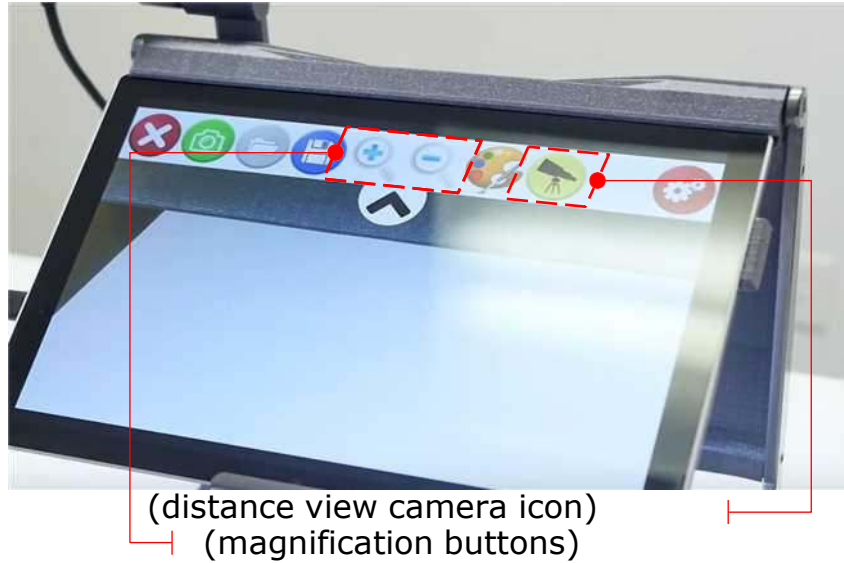

- You can zoom in and out the image by using the magnification buttons on the slide down menu.
- Pressing the bigger button allows you to zoom in to the image
- Pressing the smaller button allows you to zoom out of the image

Zoom Out Button

Zoom In Button

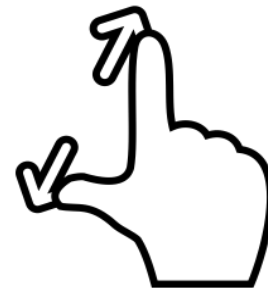
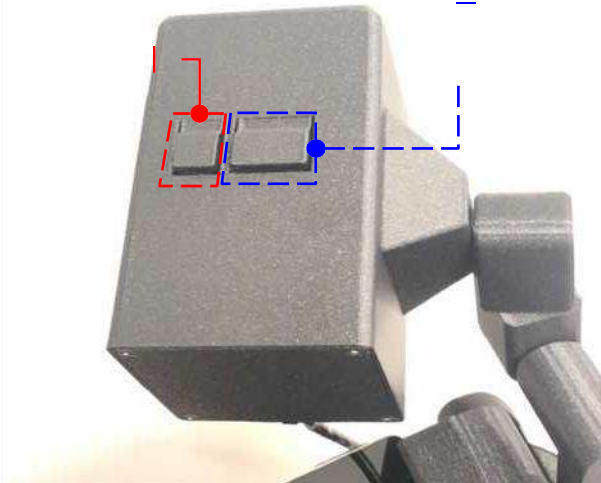

When the max zoom is reached through the button or the tablet, pinch in to the screen to allow further zooming in.

DISTANCE VIEWING

Pressing both buttons at the same time locks in the current live view and lets you control the focus manually by pressing either the bigger or the smaller button. Pressing the buttons again will bring you back to zoom in and out mode.



To view both near and far simultaneously, press the split screen icon on the menu bar to view both from the distance camera and the tablet camera on one screen. To control either of the cameras, activate the desired one by tapping its screen. The menu bar will move to indicate the active camera.



DISTANCE VIEWING

Dual Monitor



If you have a 2nd screen for the Mercury 13, rotate the monitor hook and insert it into the center slot on the stand as shown below.

DISTANCE VIEWING



Then connect one end of the USB-C monitor cable to the monitor as shown below.

DISTANCE VIEWING



Then, connect the other end of the cable to the tablet as shown below

DISTANCE VIEWING

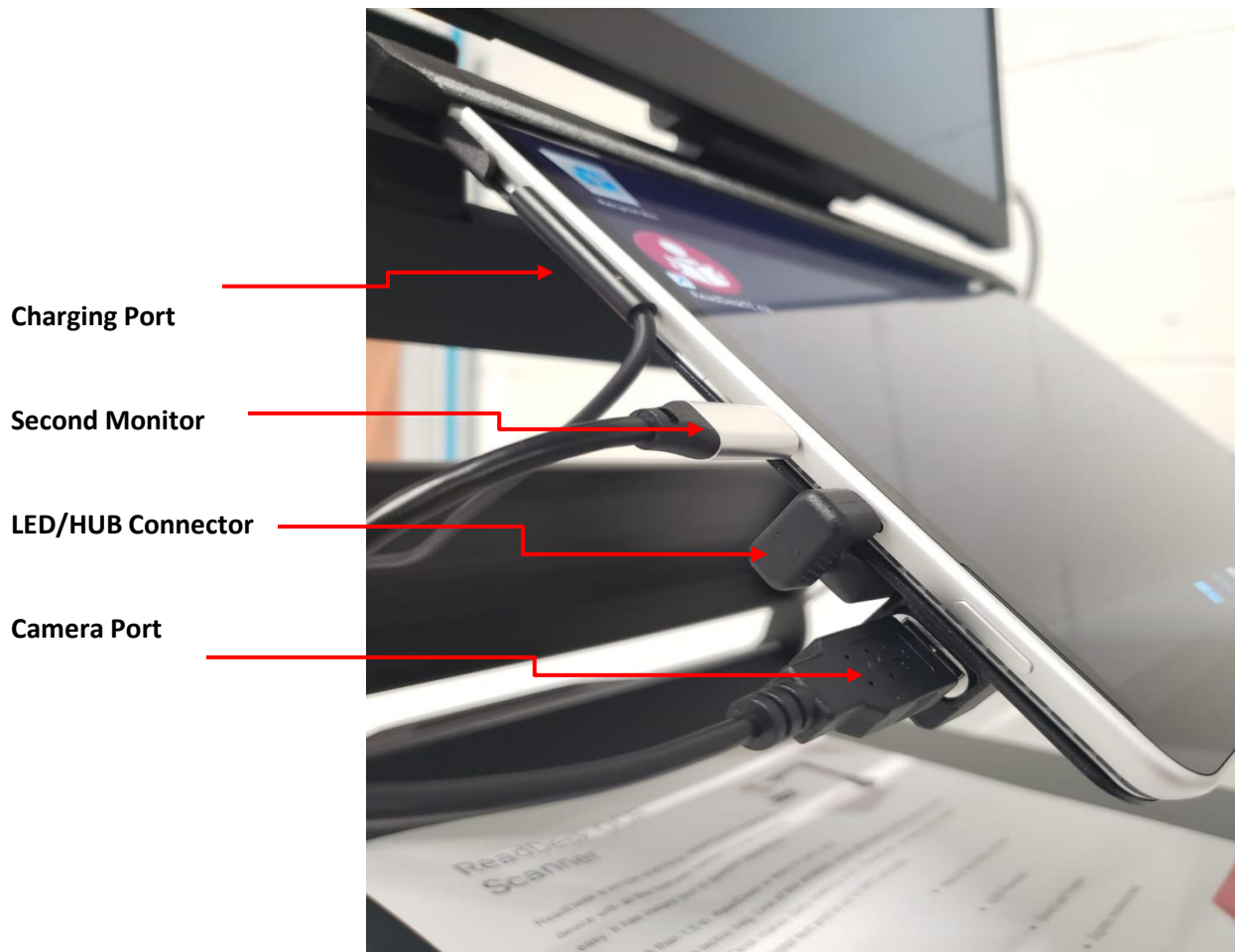

If the second monitor is not displaying any content, configure Windows Display Settings to extend the screen to the external monitor. Once content is showing on the 2nd monitor, pressing the Split Screen Icon on the ReadDesk software will automatically send the distance camera video to the 2nd monitor.

DISTANCE VIEWING

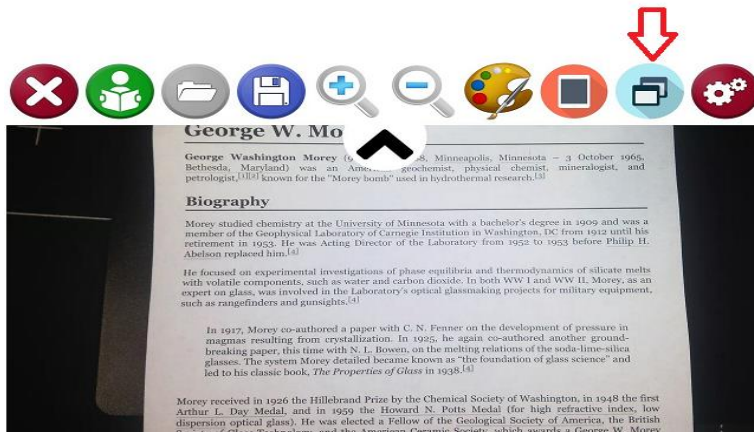

Pressing the top half of the screen will move the menu bar arrow to the top of the screen and will control the distance camera.

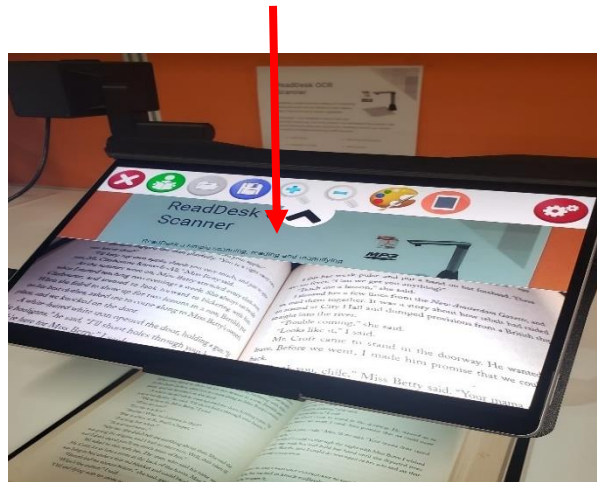

Pressing the bottom half of the screen will move the menu bar arrow to the bottom of the screen and will control the tablet camera.

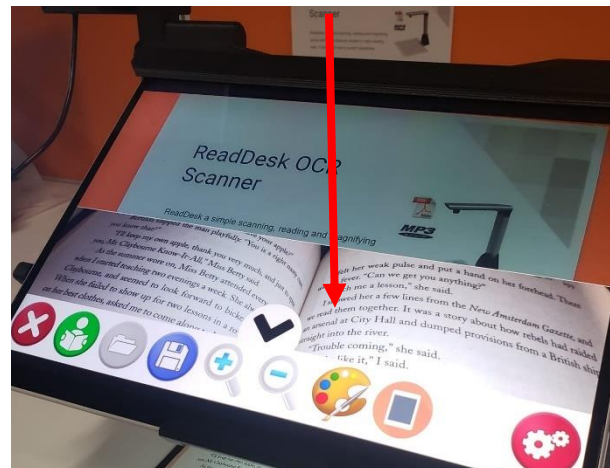

SETTINGS

Tap the Settings icon to open the settings menu.

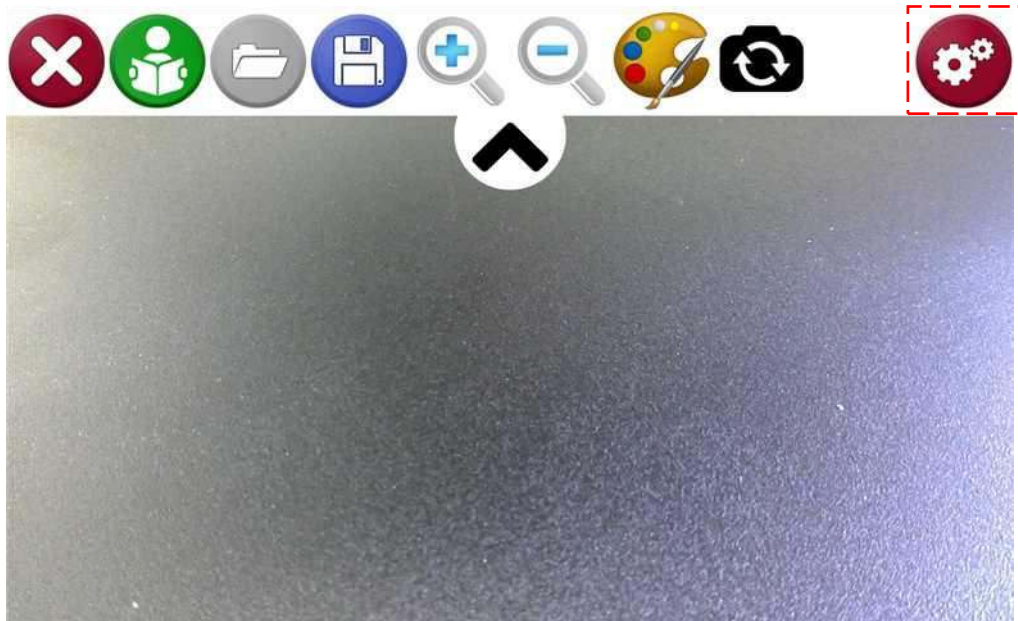

There are 3 Types of Settings

1. General Options
2. Speech Options
3. Reading Options

SETTINGS

General Options

This allows you to change the Menu, Language, Menu bar Alignment and the default folders where pictures and text files are saved.

Exit

General

Speech

Reading

Save Pictures to My Pictures /

Read Desk

Save Documents to My Documents /

Read Desk Text

Distance Camera Orientation

Original

Distance Camera Frequency

60hz

Menu Language Selection

SETTINGS

Speech Options

This allows you to change language, voices, speech volume and speech speed.

Exit

General

Speech

Reading

Language Selection

English

Voice Selection

Susan, American English

Speech Volume 100



Speech Speed 100



SETTINGS/ READING OPTIONS

This will let you switch between original and wrapped text

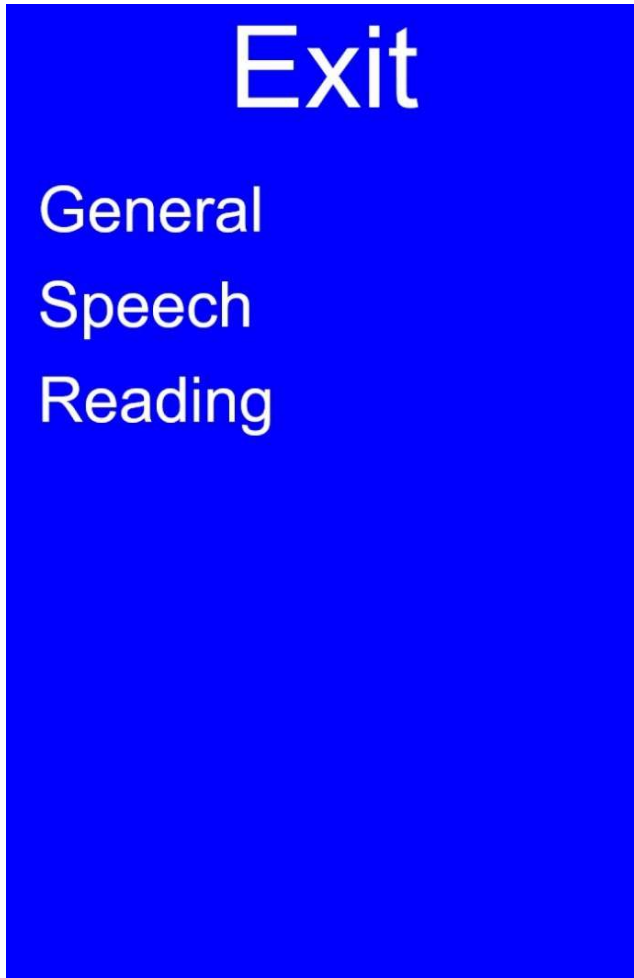

Exit

General

Speech

Reading

Reading Mode

Wrapped Mode Options

Text Size

Color Themes

SETTINGS/ READING OPTIONS

Wrapped Text

Wrapped text will digitally re-render the text in crisp text to make reading easier and fit is horizontally on the screen. However, the layout of the original document will be lost.

Original

It maintains the original layout of text while reading but the quality of the text will degrade the more you zoom in.

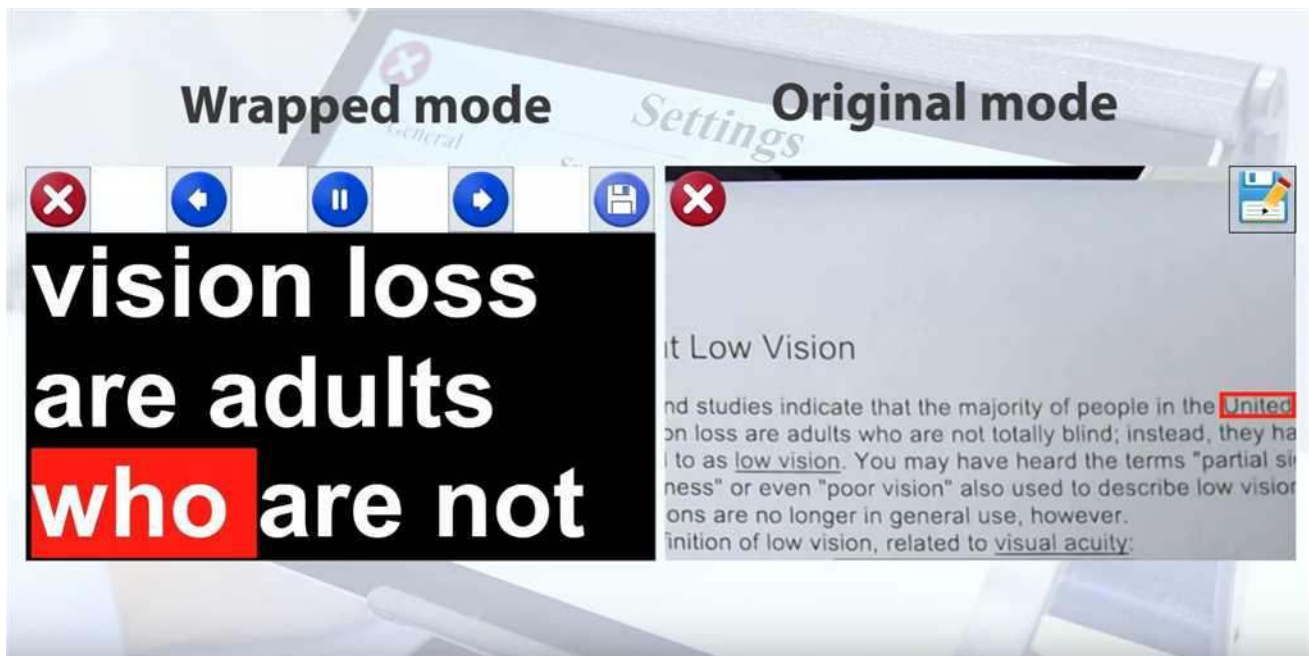

POWER OFF

To power off the device, you may use the standard Windows shutdown procedure OR press the power button for three seconds and then swipe down from the top of the screen.

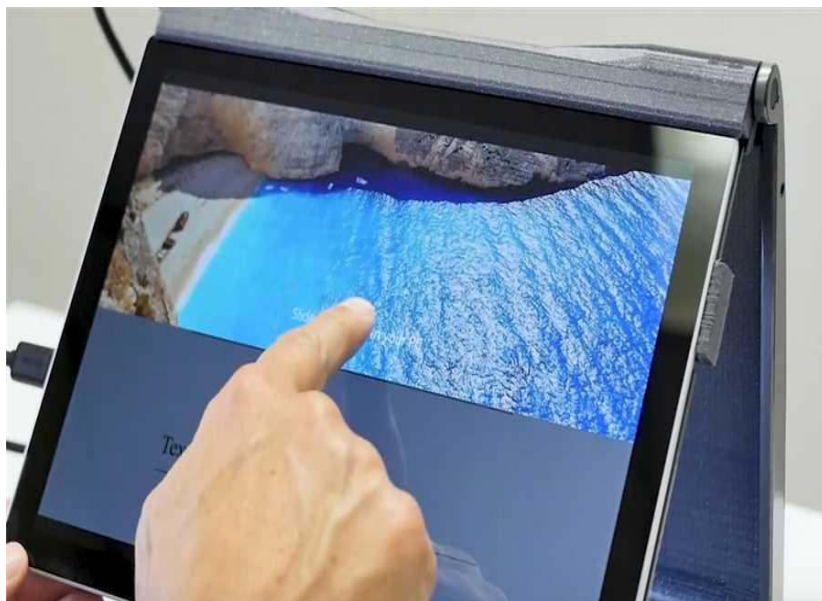

WARRANTY CONDITIONS

TrySight's **Mercury 13** warranty is free of defect in material, software and hardware for one (1) year from purchase date. This warranty extends only to the original purchaser and is not transferrable.

For any manufacturer's warranty claim/s, contact TrySight or your authorized nearest distributor. Refer to the page **35** of this user manual for TrySight's detailed contact information. Product's serial number may be asked.

Disclaimer: TrySight takes no responsibility for use of this product other than described in this user manual.

TABLET & STAND

Model	Microsoft Surface Pro 8
Screen	13"
Resolution	2880 x 1920p

Dimensions

Tablet	11.3" x 8.2" x 0.37"
Folded	12" x 13" x 2"
Unfolded	12" x 13" x 12"
Weight	2.6 kgs / 5.7 lbs

CONTACT US

You can either contact your nearest authorized dealer or you may also contact us directly at:



Visit us online:

www.trysight.com



E-mail us:

sales@trysight.com



Call us:

1-866-499-2921



Meet us:

2364 Haines Rd, Unit 16, Mississauga, ON,
Canada, L4Y 1Y6

For online video tutorials on operating the **Mercury 13**, please visit:
<https://trysight.com/tutorials/>

