

FUTURE CALL LLC

**BIG BUTTON PHONE
WITH ONE TOUCH DIALING
AND 40db HANDSET VOLUME**

MODEL: FC-1507

**SPECIAL NEEDS
COMPUTERS 
1-877-724-4922**



USER MANUAL

- Please follow instructions for repairing if any otherwise do not alter or repair any parts of device except specified.

IMPORTANT SAFETY INSTRUCTIONS{

Before using your telephone equipment, basic safety precautions should always be followed to reduce the risk of fire, electric shock and injury to persons including the following: {

1. Read and understand all instructions. {
2. Follow all warnings and instructions marked on the product. {
3. Unplug this product from the wall outlet before cleaning. Do not use liquid or aerosol cleaners. Use a damp cloth for cleaning.
4. Do not use this product near water, for example, near a bath tub, wash bowl, kitchen sink, or laundry tub, in a wet basement or near a swimming pool. {
5. Do not place this product on an unstable cart, stand, or table. The product may fall causing serious damage to the product. {
6. Slots and openings in the enclosure and the back and bottom are provided for ventilation, to protect it from overheating. These openings must not be blocked or covered. The openings should never be blocked by placing the product on a bed, sofa, rug, or other similar surface. This product should never be placed near or over a radiator or heat register. This product should not be placed in a built-in installation unless proper ventilation is provided.
7. This product should be operated only from the type of power source indicated on the marking label. If you are not sure of the type of power supply to your home, consult your dealer or local power company.
8. Do not allow anything to rest on the power cord. Do not locate this product where the cord will be abused by persons walking on it.
9. Do not overload wall outlets and extension cords as this can result in the risk of fire or electric shock.
10. Never push objects of any kind into this product through cabinet slots as they may touch dangerous voltage points or short out parts that could result in a risk of fire or electric shock. Never spill liquid of any kind on the product.
11. Do not disassemble this product, but take it to a qualified service technician or service center when repair work is required. Opening or removing covers may expose you to voltage or other risks. Incorrect reassembly can cause electric shock when the appliance is subsequently used.
12. Unplug this product from the wall outlet and refer to qualified service personnel under the following conditions:
 - A. When the power supply cord or plug is damaged or frayed.
 - B. If liquid has been spilled into the product.
 - C. If the product has been exposed to rain or water.
 - D. If the product does not operate normally by following the operating instructions. Adjust only those controls that are covered by the operating instructions. Improper adjustment of other controls may result in damage and may require extensive work by a qualified technician to restore the product to normal operation.
 - E. If the product has been dropped or the enclosure has been damaged.
 - F. If the product exhibits a distinct change in performance.
13. Avoid using a telephone during an electrical storm. There may be a remote risk of electric shock from lightning.
14. Do not use the telephone to report a gas leak in the vicinity of a leak.
15. Never install telephone wiring during a lightning storm.
16. Never install telephone jacks in wet locations unless the jack is specifically

designed for wet locations.

17. Never touch uninsulated telephone wires or terminals unless the telephone line has been disconnected at the network interface.

SAVE THESE INSTRUCTIONS

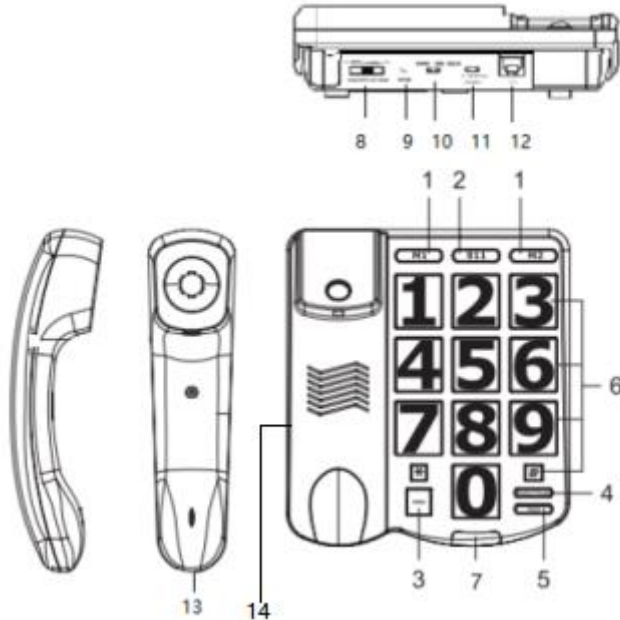

1	Direct Memory Keys	8	Slide Handset Volume Switch
2	911 memory Key	9	Store Push Key
3	MEM Key	10	ONE TOUCH-NORMAL SWITCH
4	Redial/Pause Key	11	Ringer OFF-LOW-HI Switch
5	Flash Key	12	Line Jack Socket
6	Dialing Key	13	Handset Socket
7	Ringer Light	14	Handset Socket

INSTALLATION

Coil Cord Connection

Insert coil cord into modular jack located on left hand side housing. Connect the other end into the modular jack located on handset.

Line Cord Connection

Insert the modular plug of the straight cord into the rear side of base unit, the insert the other end of RJ11C plug into the wall jack.

OPERATION

KEY FEATURE

Last Number Redial / Pause

Your PHONE remembers the last number dialed. If the number you dial is busy or not being answered, hang up. To redial the last number automatically, press the REDIAL button. NOTE: You can redial the same telephone number as many times as required. However, once you dial another number, the previous number is erased. **This key is also used as a pause key when programming this phone on a PBX system. E.G... "9" before the number**

Ringer Switch OFF / LO / HI

Your phone provides a ringer adjustment of High, Low and Off, when you don't want to be disturbed, slide the switch to the off position. Now you can still make a outgoing calls without being disturbed by incoming calls.

Handset Receiver Volume Slide control

This control may be used to adjust the handset volume of received speech.

Store Push Switch

This key is used when storing numbers into the memory

NORMAL – ONE TOUCH SWITCH

This switch is used to switch between Normal and One touch dialing mode

FLASH KEY

This key is for getting a new line if you make a mistake when dialing or it is also used to answer a call waiting call...

MEMORY FEATURE

To Program

Your PHONE is equipped with 911 memory key plus 2 one touch memory keys (M1, M2) and ten 2 touch memory keys for programming your most frequently dialed telephone numbers.

1. Slide the Normal / One touch Switch to NORMAL position.
2. Lift the handset and place it on the side. Do not listen to the handset while programming.
3. Press and release STORE button located on the back of the phone
Note: Once you start programming a number do not hesitate
4. Press the 0-9 keys for the telephone number you wish to store including area code if needed.
5. Press and release the STORE button again located on the back of the phone
6. Press the (0-9) key where you want that telephone number stored in.
7. Your number is now stored.
8. Replace handset.
9. To change a stored number, repeat the same process. The new number
Will be stored and the old number will be removed.

Note: If you need to disconnect the 911 key you may program any other number you wish or just the digit "1" into this key by following the points 1-5 push the 911 red key for point 6 then points 8-9.

To Retrieve Memory Numbers

Key button Memories:

Your phone provides the option of "Normal" or "One Touch" dialing mode.

Normal mode - To retrieve numbers stored in the key button,

Pick up the handset and wait for a dial tone then press the MEM button.

Then press the key button number (0-9) which stores the telephone number you want to dial. Your call will be automatically dialed.

One Touch mode - To retrieve numbers stored in the key button, Pick up the phone and wait for a dial tone, then press the key button (0-9) which stores the telephone number you want to dial. Your call will be automatically dialed.

Please note:

- Original Two touch memories will become one touch memories at ONE TOUCH mode
- There will be no dialing (0-9) function when the ONE TOUCH mode is selected
- You cannot program any memories when in ONE TOUCH mode

CONSUMER INFORMATION

This equipment complies with Part 68 of the FCC rules and the requirements adopted by the ACTA. On the bottom of this equipment is a label that contains, among other information, a product identifier of US: 4VKTE09BFC-1007. If requested, this number must be provided to the telephone company.

The applicable jacks (i.e. RJ11C) for this equipment are provided in the packaging with each piece of approved equipment. The jacks are certified by Universal Service Order Codes (USOC).

A plug and jack used to connect this equipment to the premises wiring and telephone network must comply with the applicable FCC Part 68 rules and requirements adopted by the ACTA. A compliant telephone cord and modular plug are provided with this product. They are designed to be connected to a compatible modular jack that is also compliant. See installation instructions for details.

The REN is used to determine the number of devices that may be connected to a telephone line. Excessive RENs on a telephone line may result in the devices not ringing in response to an incoming call. In most but not all areas, the sum of RENs should not exceed five (5.0). To be certain of the number of devices that may be connected to a line, as determined by the total RENs, contact the local telephone company. [For products approved after July 23, 2001, the REN for this product is part of the product identifier that has the format US:AAAEQ##TXXXX. The digits represented by ## are the REN without a decimal point (e.g., 03 is a REN of 0.3). For earlier products, the REN is separately shown on the label.]

If this equipment FC-1007 causes harm to the telephone network, the telephone company will notify you in advance that temporary discontinuance of service may be required. But if advance notice isn't practical, the telephone company will notify the customer as soon as possible. Also, you will be advised of your right to file a complaint with the FCC if you believe it is necessary.

The telephone company may make changes in its facilities, equipment, operations or procedures that could affect the operation of the equipment. If this happens the telephone company will provide advance notice in order for you to make necessary modifications to maintain uninterrupted service.

If you experience trouble with this equipment, disconnect it from the network until the problem has been corrected or until you are sure that the equipment is not malfunctioning.

Please follow instructions for repairing if any (e.g. battery replacement section); otherwise do not alter or repair any parts of device except specified. Connection to party line service is subject to state tariffs. Contact the state public utility commission, public service commission or corporation commission for information.

This equipment is hearing aid compatible.

NOTICE : If your home has specially wired alarm equipment connected to the telephone line, ensure the installation of this equipment FC-1007 does not disable your alarm equipment. If you have questions about what will disable alarm equipment, consult your telephone company or a qualified installer.

WARNING : Changes or modifications to this unit not expressly approved by the party responsible for compliance could void the user's authority to operate the equipment.

SERVICE

According to FCC regulation. This equipment which has been certified and registered by the FCC, may only be repaired by authorized person, the FCC certification may be voided. Should you encounter any problems, please call the FUTURE CALL LLC.

Toll-free Customer Hotline for assistance:

1-888-934-CALL, Monday - Friday between the hours of 9:00 am - 6:00 pm PST

For general inquires, you can E-Mail to futurecall@onvol.net or visit our website at www.future-call.com

FOR WARRANTY AND OUT-OF WARRANTY SERVICE:

You may call our toll-free hot line on 1-888-934-CALL (1-888-934-2255) 9AM-6PM PST or E-mail to help@future-call.com

QUESTIONS?

STOP...doesn't take unit back to the store.

LOOK...for the toll-free "help" telephone number.

LISTEN... as our experts talk you through the problem.

For immediate answers to your questions regarding operation, missing parts or installation call:

FUTURE CALL LLC

HOTLINE & E-MAIL AT:

1-888-934-CALL & help@future-call.com

LIMITED WARRANTY AND SERVICE

FUTURE CALL LLC. warrants this product to be free from defective materials or factory workmanship and will replace or repair this unit or any part thereof, except batteries, if it proves to be defective in normal use or service within 90 days from date of original purchase. Our obligation under this warranty is the repair or replacement of the defective instrument or any part thereof, except batteries. This warranty will be considered void if unit is tampered with, improperly serviced, or subjected to misuse, negligence or accidental damage. There are no other express warranties other than those stated herein.

This warranty gives you specific legal rights, and you may also have other rights which varies from state to state. TO OBTAIN SERVICE PLEASE E-MAIL US ON help@future-call.com OR CALL US TOLL FREE 1-888-934-CALL 9AM-6PM PST (1-888-934-2255). IF THE UNIT IS UNDER WARRANTY PROOF OF PURCHASE MUST BE PROVEN.