



EQUITY BI-LEVEL WITH KEYBOARD LIFT

Computer workstation with hand-crank adjustment

Parts Included

Leg Package:

- (2) Legs (A and B)
- (2) Leg Top Plates
- (2) Feet
- (4) Toe Caps
- (1) Top Crank Assembly
- (1) Drive Shaft Assembly
- (1) Hardware Bag

Keyboard Surface – Lift Package:

- (1) Keyboard Surface – Lift with Hardware

Table Package:











- (1) Cross Brace
- (2) Table Tops

Tools Needed:

- #2 Phillips Screwdriver or Power Driver

Hardware

Hardware Bag with:

- | | | | |
|---|--|------------------------------------|--|
| (2) Cross Brace Brackets |  | (4) 5/16" x 1" Fasteners |  |
| (8) 3/8" Cross Brace Bracket Fastener |  | (4) 5/16" Lock Washers |  |
| (4) #8 x 1 3/4" Wood Screws |  | (4) Levelers (or optional casters) |  |
| (8) 1/4" x 3/4" Fasteners |  | (1) 5/32" Allen Wrench |  |
| (16) #10 x 1" Screws for Leg Top Plates |  | (1) 3/16" Allen Wrench |  |



Instructions for models: EQ 361416 KBL, EQ 481416 KBL, EQ 601416 KBL, EQ 4230 CKBL

STEP ONE

Unpack and identify all parts.

Place table tops upside down on padded surface and identify front edge.

STEP TWO

Identify the legs (A and B) and their orientation as shown in the diagram.



Look at the bottom of the leg to identify the leg letter (A or B).



Legs must be positioned in correct orientation to operate. Shaft couplers face inward.

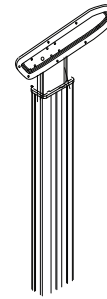

Leg B

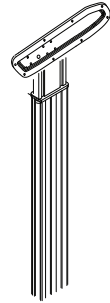

Leg A

STEP THREE

Attach leg top plates to legs using four $\frac{1}{4}$ " button head fastener per plate as shown.

$\frac{1}{4}$ " Button Head Fastener (x4)

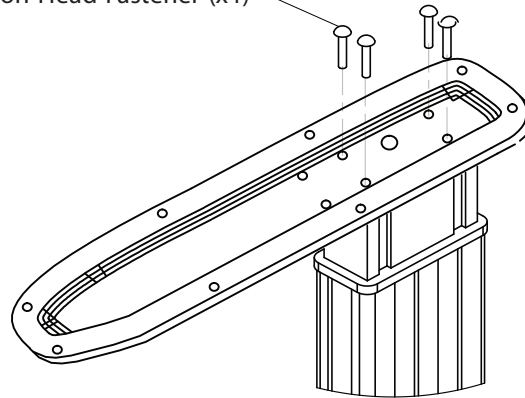

STEP FOUR

Attach feet to legs using two $\frac{5}{16}$ " button head fasteners and lock washers per foot.

Insert toe caps and levelers.



Feet are offset to the front of the table.

$\frac{5}{16}$ " Button Head Fastener (x2)

Lock Washer (x2)

Leveler (x2)

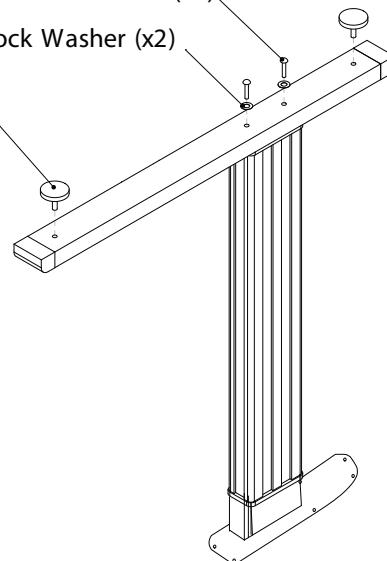

STEP FIVE

Attach cross brace bracket to cross brace using four #8 1 $\frac{3}{4}$ " screws as shown.

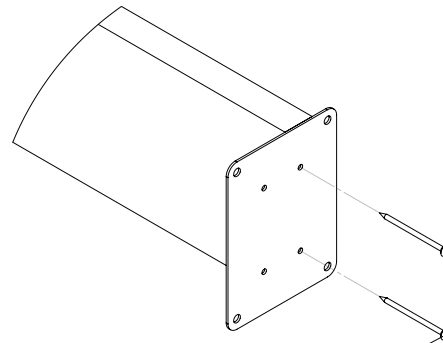

#8 1 $\frac{3}{4}$ " Wood Screw (x2)

Attach cross brace bracket to legs as shown.

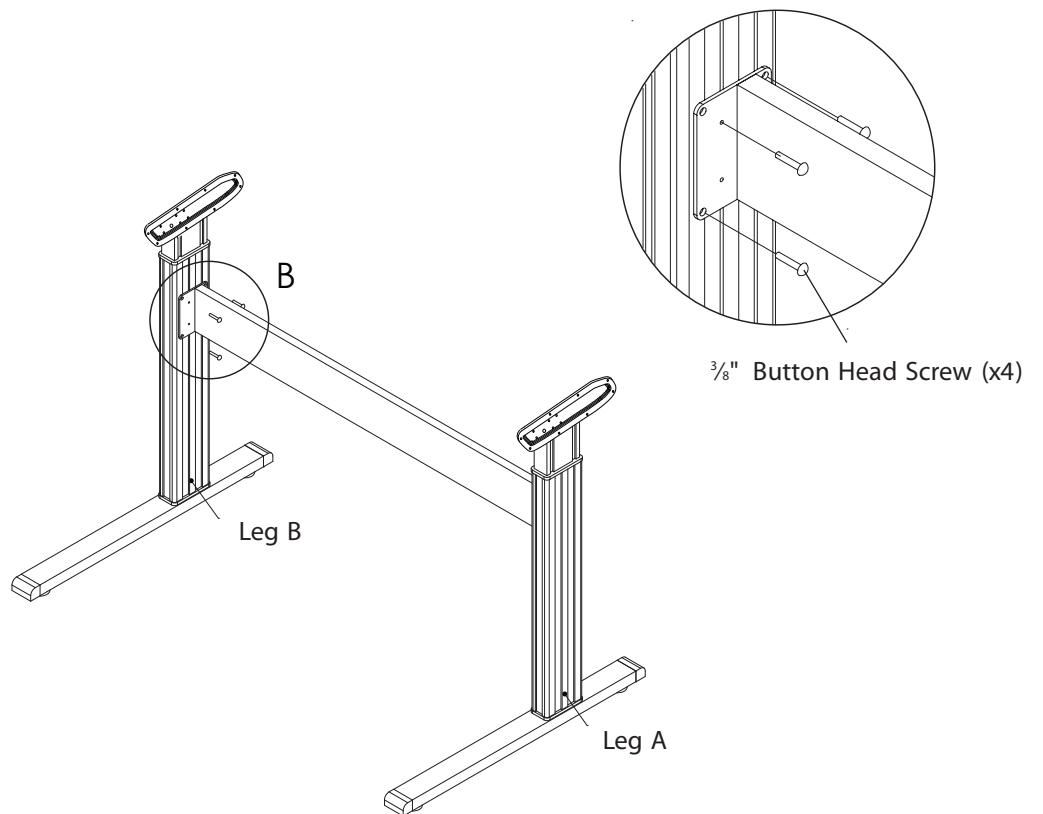

$\frac{3}{8}$ " Button Head Screw (x4)

STEP SIX

Attach mounting plates to tabletops using #10 x 1" screws.

Attach Keyboard Surface-Lift using #10 x 1" screws as shown.

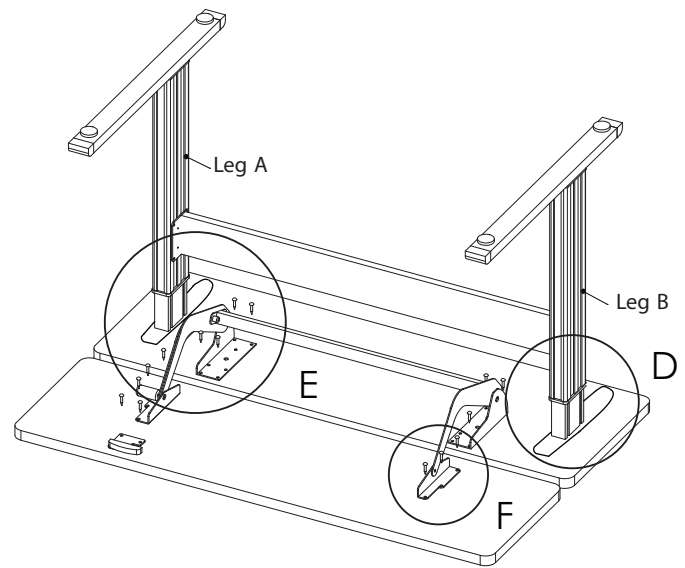

#10 x 1" Screw (x4)

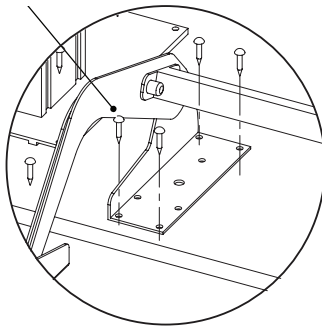

Detail: E

#10 x 1" Screw (x3)

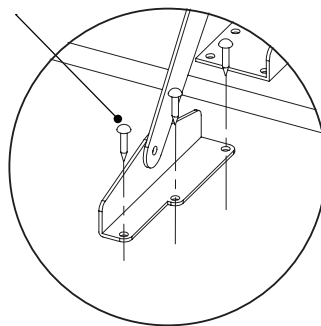

Detail: F

#10 x 1" Screws (x6)

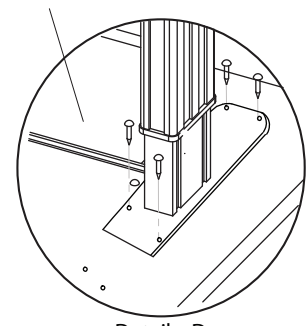

Detail : D

Insert hexagonal shafts fully into legs (front and rear).

Slide washer flush to connector tube and center tube between legs.

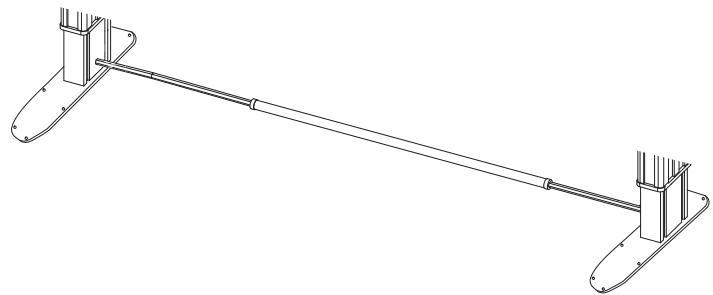

STEP SEVEN

Gently turn table over and adjust levelers if required.

Insert the top crank handle through the rear table top directly into the crank tube. Keyboard surface lift raises and lowers with front lever. Tilt adjustment is made with a knob.

Clean with soft cloth and mild cleaners suitable for furniture.