

ASSEMBLY INSTRUCTIONS



ACCELLA Workstations, desks, and tables with hand-crank adjustment

PARTS INCLUDED:

LEG PACKAGE:

- A** (2) Telescoping Legs
- B** (1) Hand-crank Assembly
- C** (2) Steel Feet
- D** (2) Table Support Braces
- (1) Hardware Bag













TABLE PACKAGE:

- E** (1) Cross Brace
- F** (1) Table Top

TOOLS NEEDED:

- Phillips Screwdriver
- Pliers or Snap Ring Pliers
- 7/16" Wrench
- 1/2" Socket Wrench

HARDWARE BAG WITH:

J (2) 1/2" Retaining Ring		Q (12) #6 x 1/2" Phillips Fasteners	
K (8) 5/16"-18 x 1" Hex Head Fasteners		R (2) 1/4"-20 x 2" Hex Head Cap Fasteners	
L (8) 5/16" Spring Washers		S (2) Curved Connector Cap	
M (4) 1/4" x 1" Hex Head Lag Fasteners		T (2) 1/4"- 20 Nylon Insert Stop Nut	
N (4) 1/4" Spring Washer		U (2) Connector Plate	
O (4) #8 x 2-1/2" Phillips Fasteners		V (4) Levelers (Or Optional Casters)	
P (12) Hydraulic Hose Clamps			

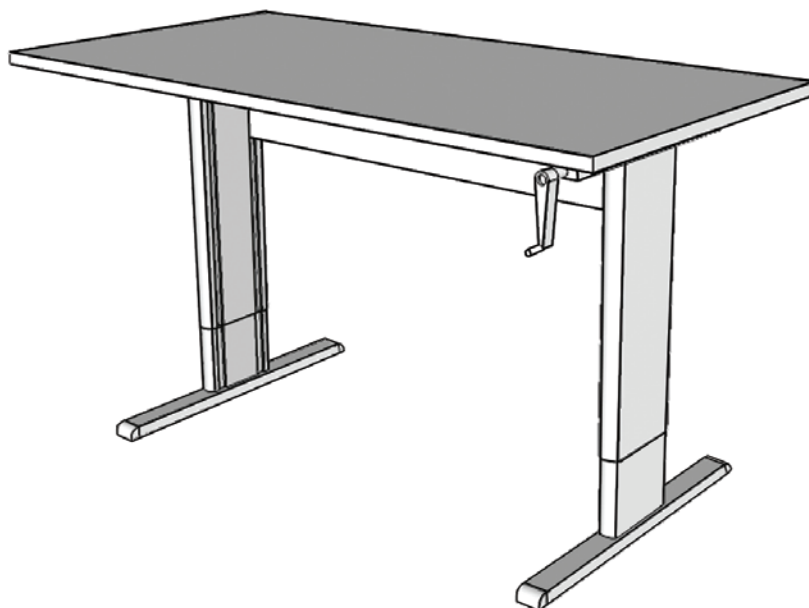

Step 1: Preparation

Unpack and identify all parts. Place Table Top (F) upside down on padded surface and identify front edge.



Be careful not to damage the hydraulic hose

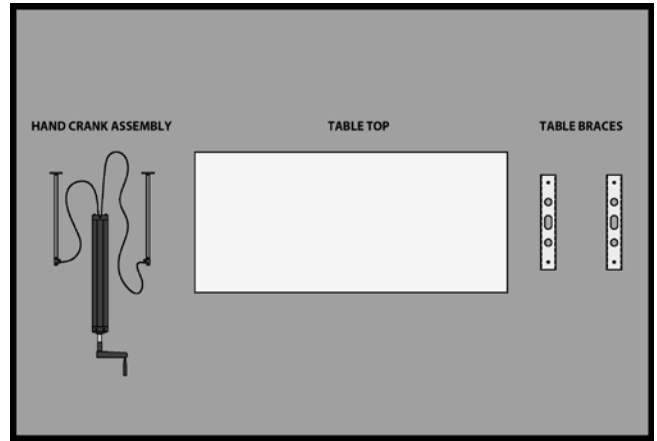

Step 2: Piston Attachment

Insert hydraulic piston into center hole of Table Support Brace (D) with piston top recessed inside brace. Secure with 1/2" Retaining Ring (J), using pliers to snap retaining ring into piston groove. Repeat for second piston. Snap ring pliers and snap rings can be used.

Snap ring pliers



Snap rings

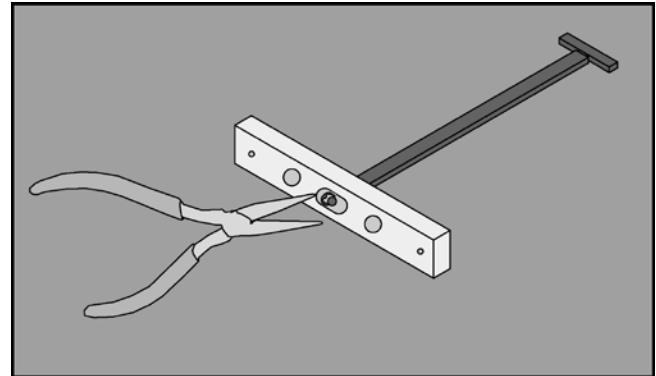

Step 3: Telescoping Leg Attachment

Insert piston foot into center of Telescoping Leg (A). Piston hose port must route through "mouse hole" of telescoping leg. Align telescoping leg with hose port facing center. Attach using two 5/16"-18 x 1" Hex Head Fasteners (K) and 5/16" Spring Washers (L). Tighten using a 1/2" socket wrench.



Keep hose routed through mouse hole to avoid pinch points

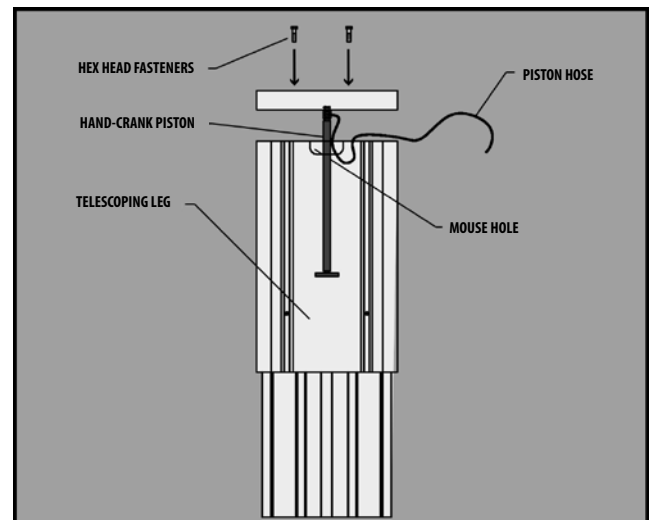

Step 4: Table Support Brace Attachment

Place Table Support Brace (D) and Hand-crank Assembly (B) on underside of table. Locate three guide holes for Hand-crank Assembly (B). Position Telescoping Leg (A) with shorter hose (A, left) closest to Hand-crank Assembly. Align Table Brace (D) to guide holes and attach using four 1/4" Spring Washers (N). Tighten using 7/16" Socket Wrench.

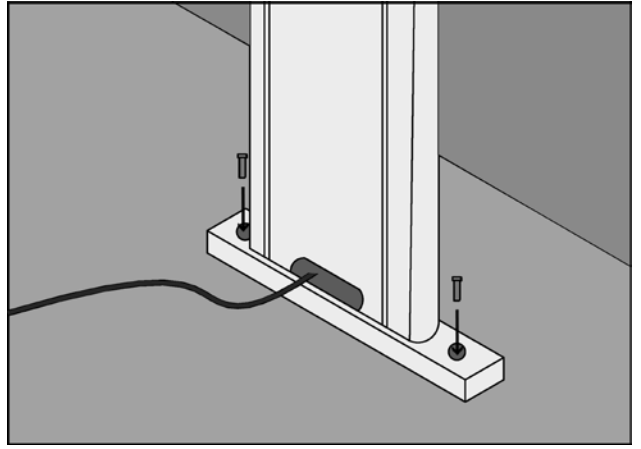

Do not over-tighten or strip



Slotted groove on telescoping legs face in

Step 5: Hand-crank Assembly Attachment

Align Hand-crank Assembly (B) to four guide holes. Attach using four #8 x 2-1/2" Phillips Fasteners (O).

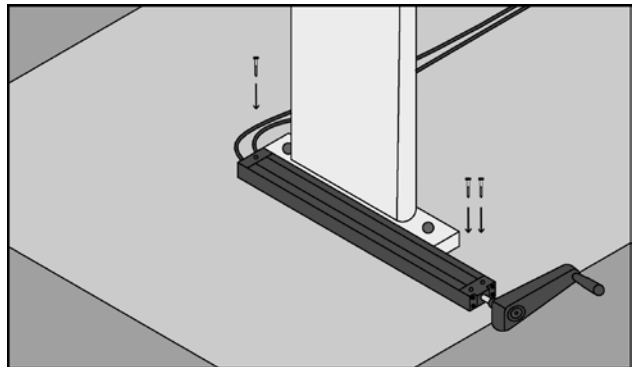

Step 6: Hose Attachment

Route hose through Hose Clamps (P) in pattern shown. Attach using #6 x 1/2" Phillips Fasteners (Q).

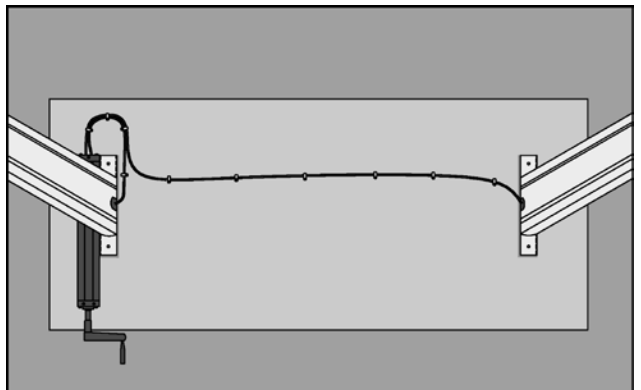

Step 7: Cross Brace Attachment

Hardware is shipped attached. Insert Hex Head of 1/4"-20 x2" Fasteners (R) into rear slotted groove of Telescoping Leg (A). Level Cross Brace (E) two inches below top of telescoping leg. Tighten using 7/16" wrench. Cover connector hardware with Connector Cap (S).

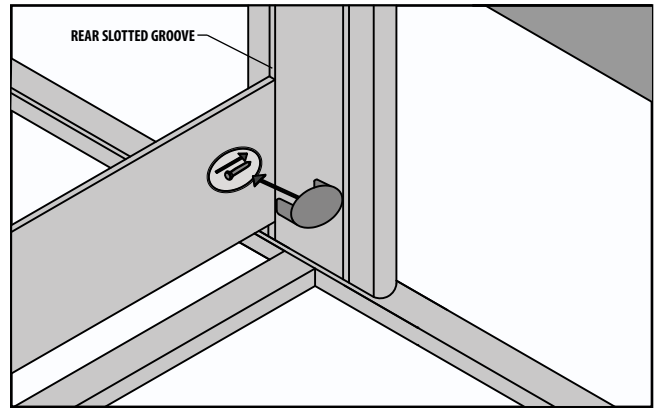

Step 8: Feet Attachment

Attach Feet (C) to Telescoping Legs (A) using two 5/16"-18x1" Hex Head Fasteners (K) and 5/16" Spring Washers (L) tighten using 1/2" socket wrench. Attach Levelers (V) or optional casters to threaded toe cap.

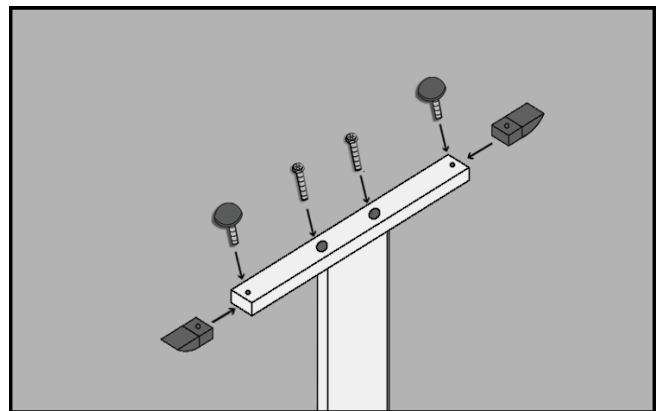

Step 9: Operation and Use

Pump handle pulls out and down to fold out of the way. Gently turn table over and adjust Levelers (V) if required. The Hand-crank raises and lowers the table. Clean with soft cloth and mild cleaners suitable for furniture.