

### Parts List

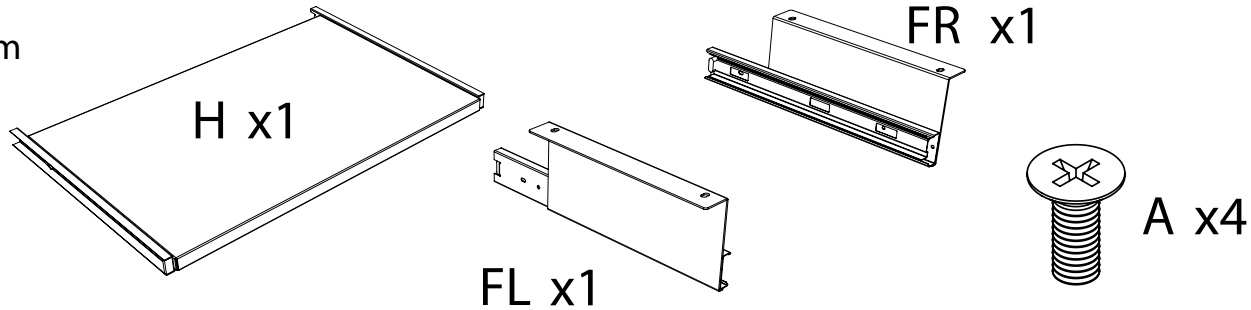

### Tools Required

- Screwdriver

### Tools in this step:

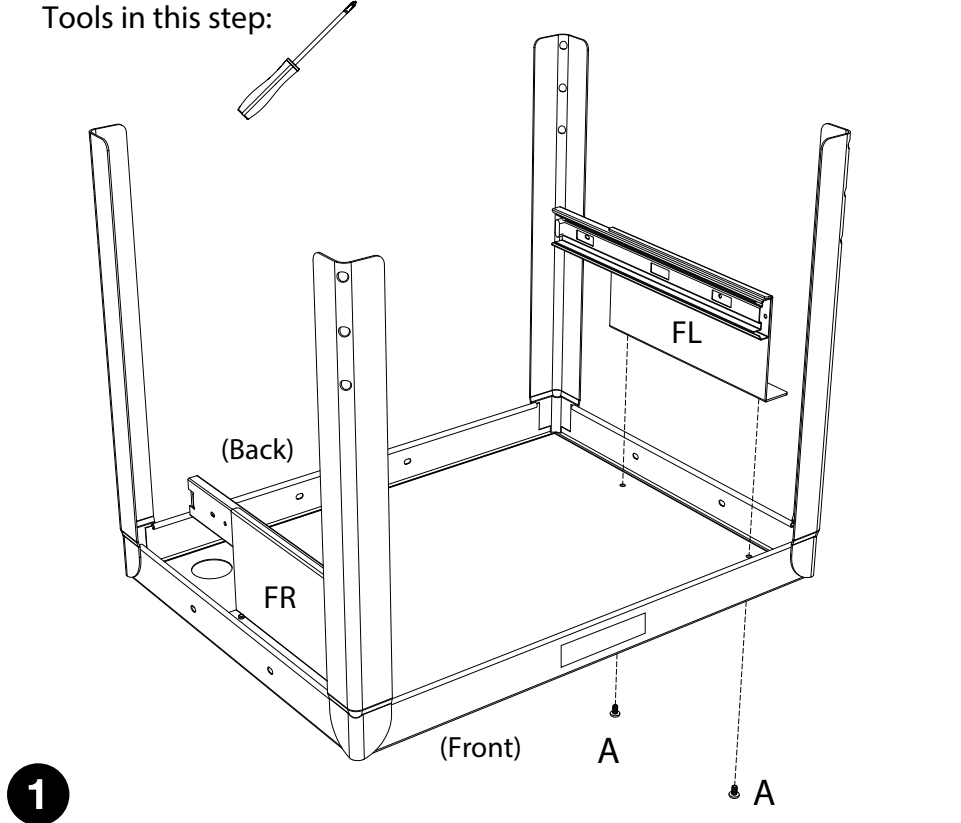

**1**

Take top shelf of metal cart and lay on side. Collect parts: FL, FR and A. Align brackets with screw holes on top of shelf. Insert screw A and tighten with screwdriver. Do not fully tighten until shelf is attached.

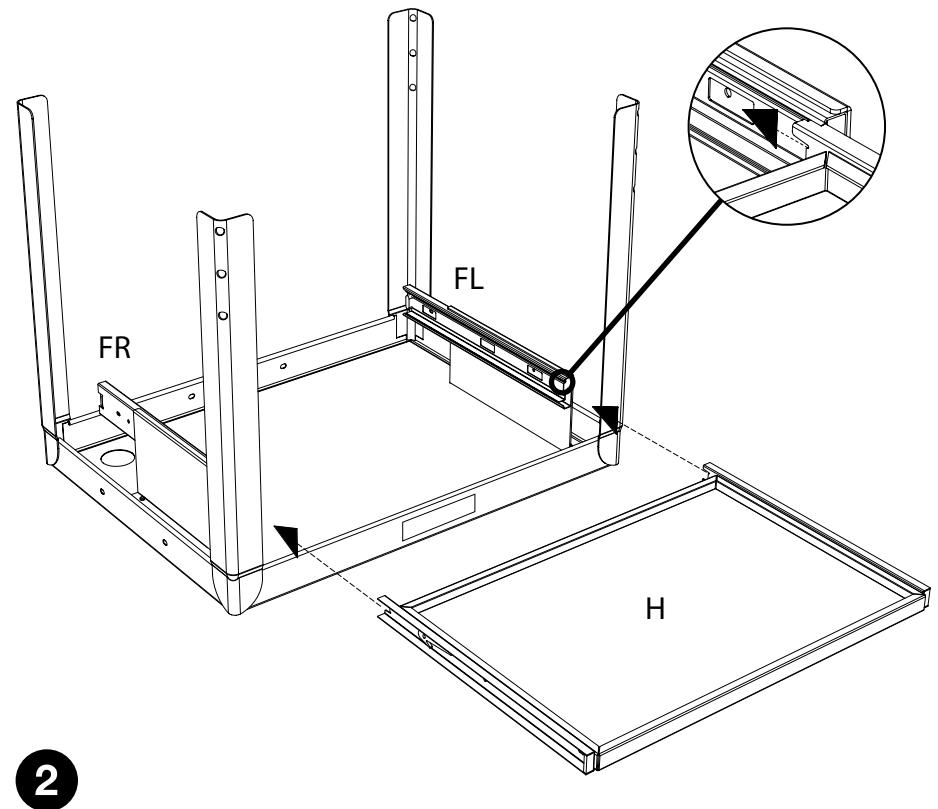

**2**

Collect part: H. Align the pullout shelf H runner so that the runner snaps into place into the FL & FR brackets. Pull the shelf out to make sure it is fully seated. Tighten screws A. Pullout keyboard shelf assembly is now complete.

# LUXOR

INNOVATIVE WORKSPACE PRODUCT SOLUTIONS

[www.luxorfurn.com](http://www.luxorfurn.com)

## Adjustable Height Metal Cart Instructions

### Parts List

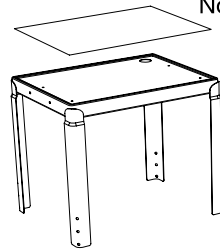

**A** x1

Non-slip mat

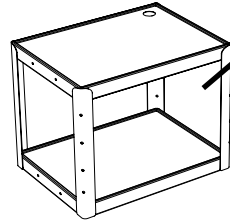

**B** x1

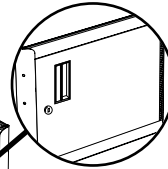

Cabinet comes pre-assembled on units that include a cabinet.

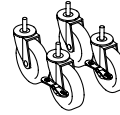

**C** x4

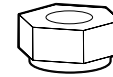

**D** x4

**E** x4

### Tools Required

- Rubber Mallet

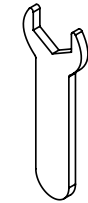

x1

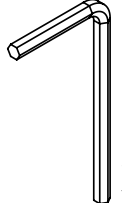

x1

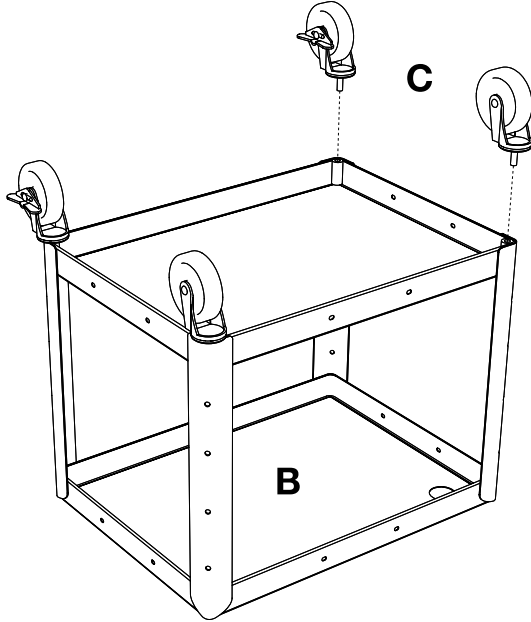

**1**

Position the bottom shelf **B** so that the caster holes are facing up. Insert caster **C** into the caster holes on the bottom of shelf **B**. Use a mallet to set the casters properly.

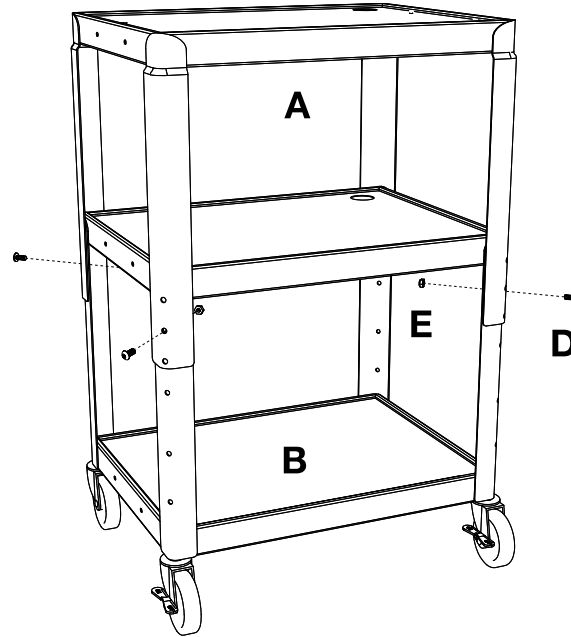

**2**

Flip bottom shelf **B** so that it is on its side. Set top shelf **A** so that it overlaps bottom shelf **B**. Align the screw holes so that the top shelf **A** is at the desired height.

Tools in this step:

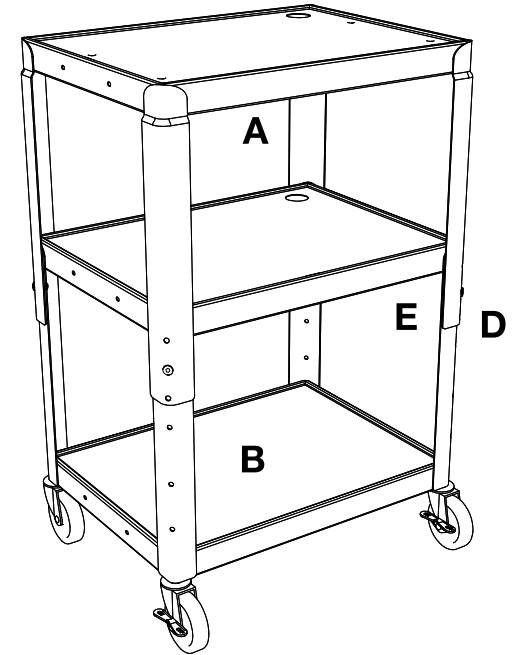

**3**

Insert screw **D** through the aligned screw hole of **A** and **B** and fasten nut **E** with wrench and allen wrench. Place Non-slip mat on desired shelf. The cart is now complete.

## Electric Assembly Instructions

Number of outlets may vary.

### Parts List

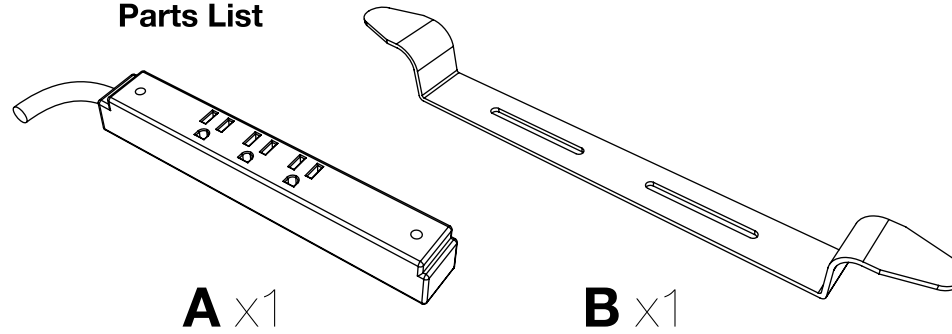

### Tools Required

- Screwdriver

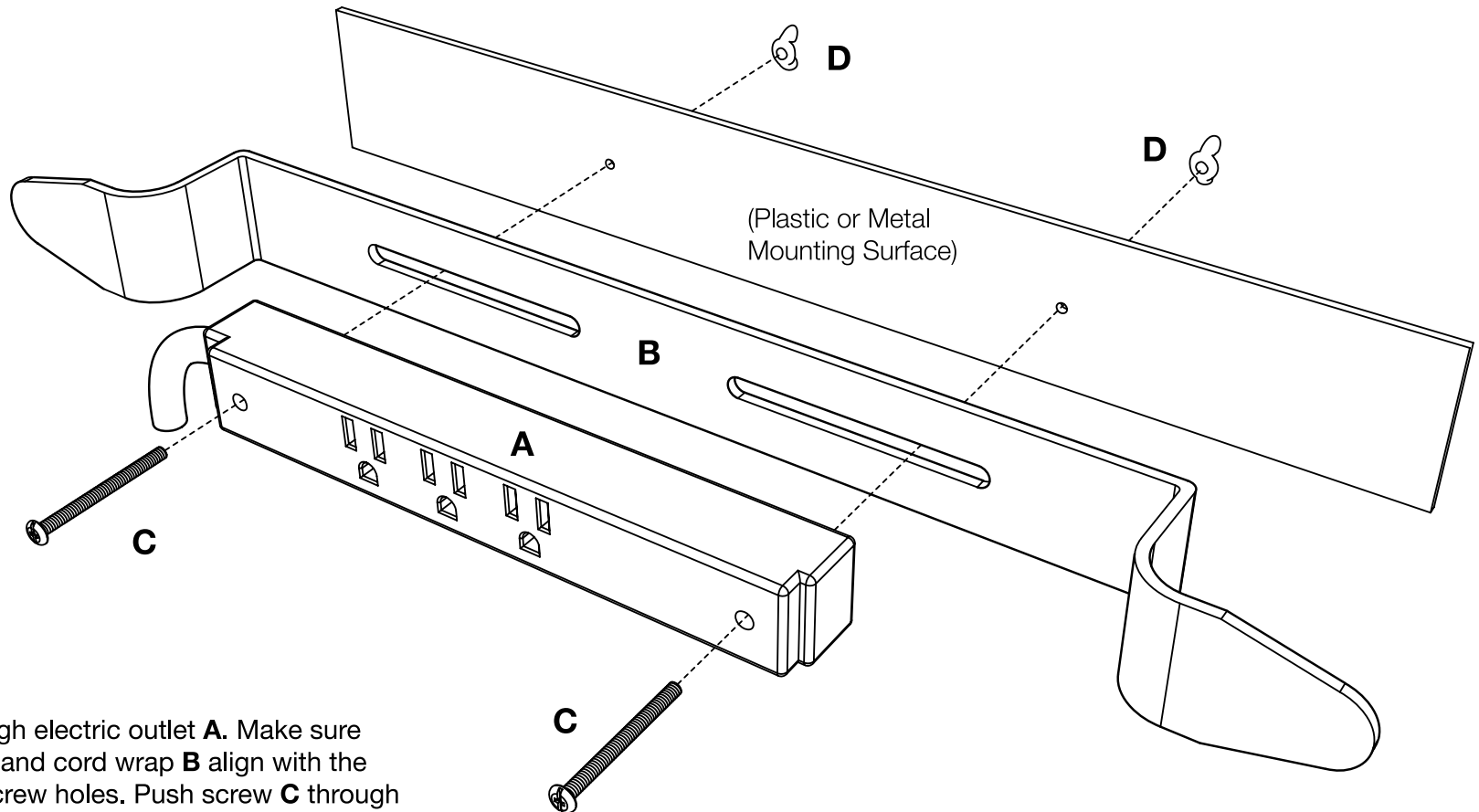
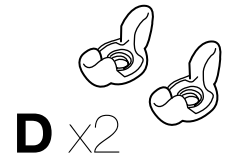
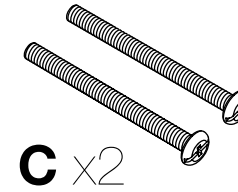

**1**

Push screw **C** through electric outlet **A**. Make sure the electric outlet **A** and cord wrap **B** align with the mounting surface screw holes. Push screw **C** through cord wrap **B** and the mounting surface screw holes. Use wing nut **D** and screwdriver to fasten.