

Components & Parts

The components and parts list will help you identify the names and part numbers of various components on your new TaskMate™.

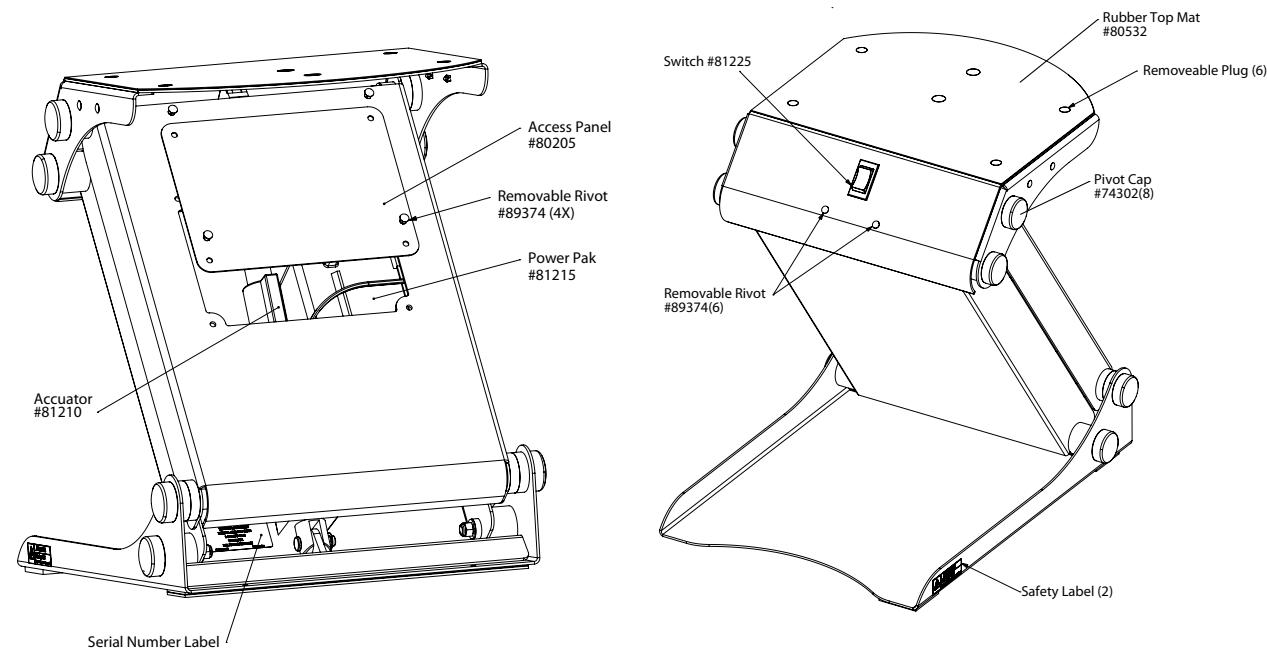

TaskMate Limited Warranty

The warranty is extended to the original purchaser/customer and commences on the purchase date from the seller/dealer. HealthPostures (HP) warrants its TaskMate to be free from defects in materials or workmanship for a period of 5 years from the date of shipment.

What is not covered by this warranty:

Normal wear and tear, Alteration or modification of the product, Abuse, misuse, or accident, Damage resulting from shipment or storage. Written notice of the defect must be given to HP within the applicable warranty period.

Any product proven to HP satisfaction to be defective and within warranty period shall be repaired or replaced at HP's option. Only HP approved components validate this warranty. This warranty does not include any labor charges incurred in replacement parts installation. No credit will be given for any repairs to damaged or defective items without prior approval of HP. HP reserves the right to require that any such items be returned to the factory for inspection.

This warranty is the only warranty made by HP, including implied warranties of marketability and fitness for a particular purpose are hereby disclaimed. Damage resulting from misuse, negligence, accident or alterations are excluded and will not be paid. HP shall not be liable for any consequential or incidental damages whatsoever.

Owner's Manual



This manual is an integral part of your TaskMate™ unit and should be read thoroughly by anyone that will be operating the unit. This will ensure the TaskMate™ is assembled and used properly.

It is important and necessary that you inspect your TaskMate™ periodically to assure that it is in safe operating condition. Minor adjustments can be made by the operator. Replacement of worn parts, major adjustments or any other important corrections should be handled by an authorized dealer or service center. To ensure safety and performance, only HealthPostures approved replacement parts should be used.

Date Purchased _____ Serial Number _____



14310 Ewing Ave. S., Suite 100, Burnsville, MN 55306 (p)800.277.1841 (f)952.873.3741
www.healthpostures.com



Safety Precautions

Please be sure to read the entire contents of this manual before operating your new TaskMate™ monitor and keyboard positioning unit. This manual contains important information concerning safety, maintenance and proper use of the TaskMate™.

- 1** Keep your work area clean. Objects can get under the TaskMate™ and cause damage to the unit and/or personal property.
- 2** **Do not lean** on or place anything heavier than 15 lbs. on the keyboard tray. Over loading the keyboard tray can cause the TaskMate™ to tip forward resulting in personal injury.
- 3** **Do not** abuse the power cord. Never pull the plug from the outlet by the cord. Keep cord from heat, sharp edges or moving parts. A damaged cord increases the risk of electric shock. Discontinue use if cord is cut or frayed.
- 4** **Do not** expose unit to rain or wet conditions. Water entering the power unit will increase the risk of electric shock. Discontinue use if your TaskMate™ is exposed to wet conditions.
- 5** **Do not** load more than 70 lbs. on to the TaskMate™. Over loading can cause the unit to become top heavy and off balanced causing personal injury or property damage.
- 6** **Use only** accessories that are recommended by the manufacturer. Using accessories not suitable for the TaskMate™ may cause the unit to be off balanced causing personal injury or property damage.

Safety Notice



- The TaskMate™ must be secured to a sturdy surface.**
1. Surface must be flat and free of dust and oil.
 2. Place the TaskMate™ in a place with the front of the unit flush with the front of the desk.
 3. Lift up the back of the unit and remove the plastic from the hook and loop as shown. Press down firmly.



- Securing a flat panel monitor to the TaskMate™. Once the monitor is in place, mount the security strap to the hook strip under the top rail of the TaskMate™ as shown.**



Option Assembly

Adjustable Keyboard Mechanism (6100 & 6200)

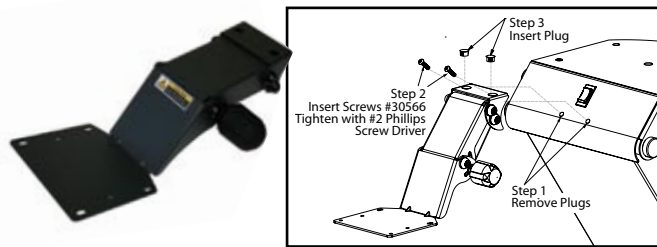

- Step 1** Remove plugs from TaskMate.
- Step 2** Align keyboard mechanism to TaskMate™. Insert screws and tighten with a #2 Phillips screw driver.
- Step 3** Insert plugs.

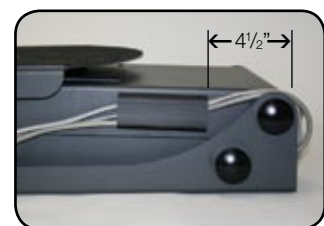

Wire Management

Remove paper from adhesive back and attach the wire management harness to the side of the TaskMate as shown.

Keyboard Tray (6100 & 6200)

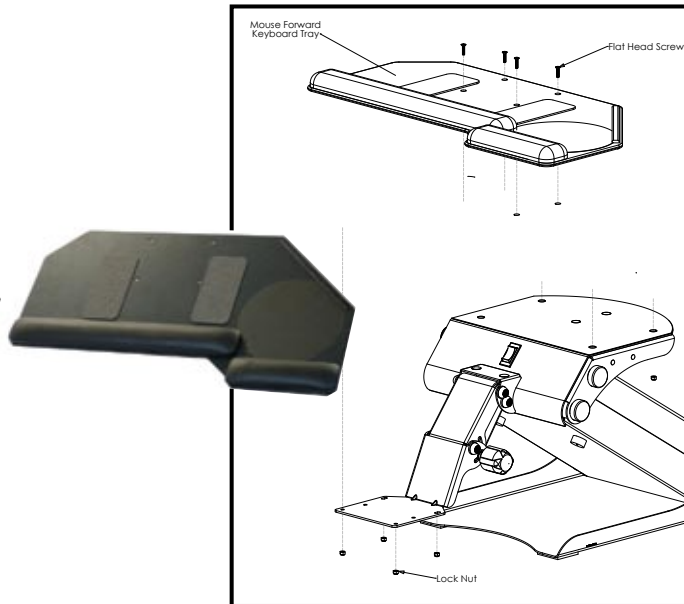

- Step 1** Mount the keyboard tray to the mechanism from the top using the supplied screws and a Phillips screwdriver.
- Step 2** Tighten locknuts to screws under the keyboard tray.

Option Assembly (continued)

Copy/Phone Holder 8" x 10" (6142)

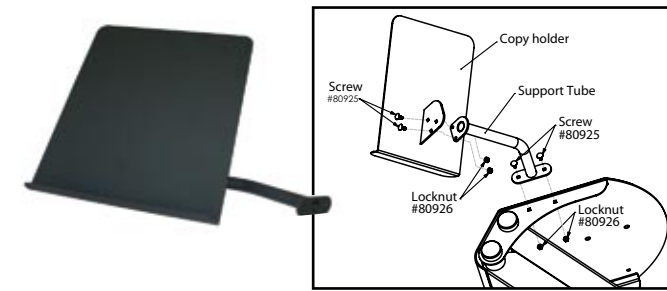

- Step 1** Align support tube holes to copy holder bracket as shown. Insert screws and attach to support tube and tighten locknuts.
- Step 2** Remove plugs from TaskMate™.
- Step 3** Align support tube holes to TaskMate™. Insert screws and tighten locknuts.

Computer TaskMate Tabletop 36" x 14" (6155)

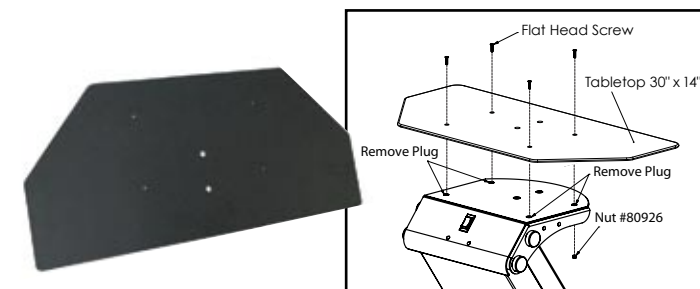

- Step 1** Raise TaskMate™ to the highest position
- Step 2** Remove plugs from TaskMate™
- Step 3** Place tabletop on TaskMate™ and align holes.
- Step 4** Insert screws from the top.
- Step 5** Fasten locknuts from beneath the TaskMate™ platform.

Dual Monitor w/articulating Arm (6912) /Notebook & Monitor Arm (6915)

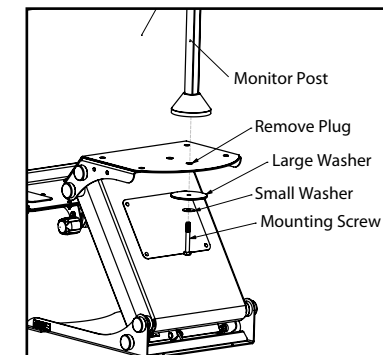

- Step 1** Raise TaskMate™ to the highest position
- Step 2** Remove plugs from TaskMate™
- Step 3** Align large washer, small washer and mounting screw from beneath the TaskMate™ as shown.
- Step 4** Align the bolt with the hole in the base of the monitor post.
- Step 5** Tighten the bolt

Surface TaskMate Tabletop 36" x 20" (6250)

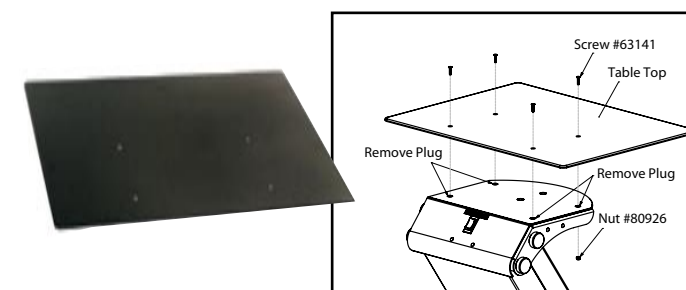

- Step 1** Raise TaskMate™ to the highest position
- Step 2** Remove plugs from TaskMate™
- Step 3** Place tabletop on TaskMate™ and align holes.
- Step 4** Insert screws from the top.
- Step 5** Fasten locknuts from beneath the TaskMate™ platform.

Call a HealthPostures Authorized Dealer for service or repair information.