

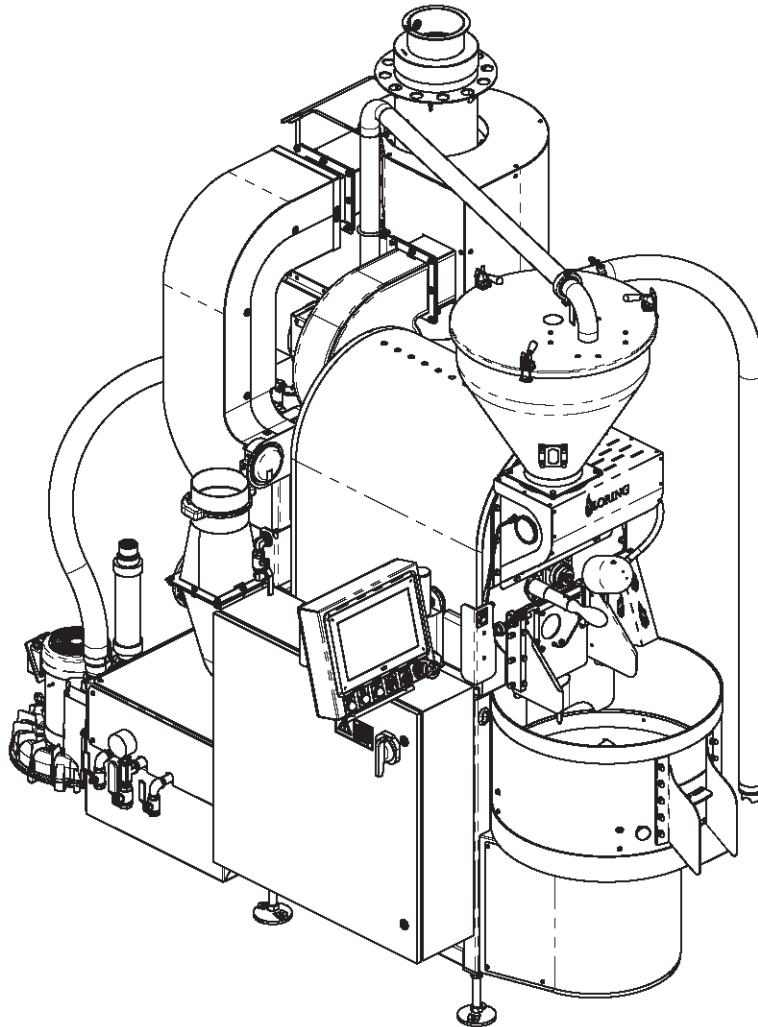

L O R I N G



# Pre-Installation and Site Preparation Guide

Loring S15 Falcon™ Coffee Roaster

This page intentionally left blank.

# Notices

## Document Versioning Information

**Document No. 1008236 Rev B**

**Date Last Exported: September 3, 2018**

© Loring Smart Roast, Inc. All rights reserved.

The name LORING SMART ROAST, the Loring logo, and the catchphrase “The Smarter Way To Roast” are all trademarks of Loring Smart Roast, Inc.

Warranty is void unless product is installed and used in accordance with all written instructions.

This manual, along with other manuals in this series, is intended to be a guideline for the installation and use for the product lines manufactured by Loring Smart Roast, Inc. The customer is responsible for complying with all applicable regulations.

The customer should refer to a licensed professional contractor or contractors for all installation details.

## Dangers, Warnings, and Cautions

Throughout this manual, the following signal words are used to identify the degree of seriousness in any operation that presents a potentially hazardous situation.



**DANGER:** Indicates a hazard that **WILL** cause severe personal injury, death, or substantial property damage if ignored.



**WARNING:** Indicates a hazard that could cause **SEVERE** personal injury, death, or substantial property damage if ignored.



**CAUTION:** Indicates a hazard that could cause **MINOR** personal injury or property damage if ignored.

## Pre-Installation and Site Preparation Guide General Notes

Follow all written instructions provided by Loring, and verbal instructions from Loring Customer Support, regarding site preparation prior to receiving the coffee roasting equipment.

All contractors or subcontractors involved in installation or working with specific connections (e.g., water, air, gas, electrical, hot and cold exhaust ventilation) should be fully licensed and qualified in that particular functional area.

Comply with all applicable rules and regulations and governing agencies.

Loring reserves the right to change information within this document at any time without notice.



# Contents

<b>Introduction</b>	<b>7</b>
Audience	7
Acquiring a Coffee Roaster	7
<b>S15 Specifications</b>	<b>9</b>
Requirements for Utilities	10
Power Specification	11
<b>Dimensions and Clearances</b>	<b>13</b>
Overall Footprint	13
Footprint – S15 Roaster	14
Floor Clearances – S15 Roaster	15
Overhead Clearances – S15 Roaster	16
Footprint - S15 Roaster Feet	17
45-Degree Vent Kit	18
<b>Space Planning</b>	<b>20</b>
Indoors	20
Floor	20
Stack Connection Location	21
Door Openings	22
Local Codes	23
Utilities	23
Room Size and Ventilation	23
Low Ceiling	24
Multi-Story Buildings	24
Workflow Space	25
Lighting	27
Network	27

<b>Receiving Shipment</b>	<b>28</b>
Shipping Notes	28
S15 Shipping Crate	29
Lifting and Moving the Roaster	31
<b>Next Steps</b>	<b>34</b>
Site Preparation Checklist	34
<b>Gas and Gas Supply</b>	<b>35</b>
Propane Fuel Installation Specifications	36
Natural Gas Installation Specifications	37
<b>Installing the Vent Stack</b>	<b>38</b>
Vent Stack Configurations	40
Adjusting Roaster to the Vent Stack	44
<b>Manufacturer Contact Information</b>	<b>46</b>

# Introduction

## Audience

The intended audience for this manual, the *S15 Pre-Installation and Site Preparation Guide*, includes customer-side administrators, floor employees, general contractors, facilities managers and other individuals who are responsible for preparing the site for installation of the roaster.

## Acquiring a Coffee Roaster

Preparing for and installing a Loring coffee roaster requires cooperation between the customer and Loring over several weeks. Generally, the customer should begin preparing the site 3 months prior to shipping. Upon receiving the roaster, the customer's general contractor assembles the roaster, connects the utilities including water, gas, and electric, connects the hot and cold exhaust ventilation, and then waits for the Loring Field Service Technician to perform final system commissioning. The commissioning period also includes hands-on customer training in the use and maintenance of the roaster.

Some tasks, such as ordering stack ventilation components, may require specifying and purchasing equipment from third-party suppliers. Allow sufficient lead times.



**WARNING:** Operating the roaster prior to final inspection and commissioning by an authorized Loring Field Service Technician will void the warranty.

## Additional Documentation

The following additional documentation is available to aid with installation and setup. Contact your Loring Account Representative for more information.

- **Welcome Packet.** The *Welcome Packet* contains detailed instructions and information sent by Loring to each new customer upon purchase of a coffee roaster. One item, the Product Specification Form, must be completed and returned to Loring in order for Loring to begin building the roaster.
- **Product Specification Form (PSF).** The customer must provide information to Loring regarding the site's utility characteristics. This information is used to configure the roaster at the factory, a process that requires several weeks' lead time. Loring strongly recommends working with a licensed professional contractor when providing this information. This form is included in the *Welcome Packet*.
- **Suggested Stack Manufacturers.** One of the items in the Welcome Packet is a list of recommended manufacturers of stack ventilation components. Loring recommends ordering stacks 6 weeks prior to the arrival of the roaster.
- **Installation and Assembly Guide.** After receiving the coffee roaster, the customer must engage with a licensed general contractor to assemble, position, and hook up the roaster to various utilities and stack ventilation.
- **Mechanical Interface Control Documents (MICDs).** These technical drawings provide detailed information on system dimensioning and components, as well as system weights. They are intended for permit submittals and for use by general contractors, as well as by architects and facilities planners. These drawings are available upon request from Loring.
- **Special Reports for Permitting.** Additional reports on various technical subjects are available from Loring. Each customer may need to satisfy unique local or regional regulatory requirements. For example, air quality reports are typically required, and some locations may require both county and city permits.

The *Product Specification Form (PSF)* conveys extremely important customer information regarding the customer site's power supply voltage and network configuration. Loring requires this form to be completed by the customer a minimum of 9 weeks prior to production completion. Any delay in providing any portion of this information can delay the roaster production by a corresponding number of weeks.

# S15 Specifications

**Table 1. S15 Basic Equipment Specifications**

S15 Specification	Value
<b>System Weight <sup>1</sup></b>	1573 lb (714 kg) uncrated
<b>Maximum Batch Size</b>	33 lb (15 kg)
<b>Minimum Batch Size</b>	6.6 lb (3 kg)
<b>Nominal Electrical Power</b>	2.8 kW
<b>Peak Electrical Power</b>	5.8 kW
<b>Maximum BTU Rating</b>	130,000 BTU/hr (33 K kcal/h)
<b>Hot Stack Max Continuous Temperature <sup>2</sup></b>	1400 °F (760 °C)
<b>Hot Stack Max Intermittent Temperature <sup>2</sup></b>	1500 °F (816 °C)
<b>Hot Stack Max Flow <sup>3</sup></b>	22 dscfm (37 dsm <sup>3</sup> /h)
<b>Hot Stack Max Flow (Peak Air Cool) <sup>5</sup></b>	310 dscfm (527 dsm <sup>3</sup> /h)
<b>Hot Stack Minimum Duct Diameter <sup>4</sup></b>	6 in (152 mm)
<b>Cooling Exhaust Max Flow <sup>5</sup></b>	980 scfm (1670 sm <sup>3</sup> /h)
<b>Cooling Duct Diameter <sup>4</sup></b>	6 in (152 mm)

**Notes:**

- 1 Exact system weight may depend on options selected.
- 2 Consult local and regional regulations for air quality, temperature, and emissions restrictions.
- 3 Dry, or water content of the flue removed, under standard pressure and temperature conditions, i.e. 29.9 in HG (760 mm HG) and 68°F (20°C).
- 4 Larger stack diameters or stack openings may be required under some conditions.
- 5 Add the Hot Stack Max Flow (Peak Air Cool) and Cooling Exhaust Max Flow to obtain the total air flow out of the building. This may be needed in the event that additional air intake, otherwise known as makeup air, is needed at the installation site.

# Requirements for Utilities

In order to ensure proper roaster performance, the customer should verify that the site utilities meet basic requirements for water, compressed air, and gas. The customer must indicate whether the site uses natural gas or propane.

**Table 2. S15 Utilities Requirements**

S15 Specification	Value
<b>Water Supply (Flow) Minimum</b>	1 GPM (3.8 LPM) or greater
<b>Water Pressure Minimum</b>	50 psi (345 kPa) or greater
<b>Compressed Air Flow, Minimum</b>	4 CFM (0.11 m <sup>3</sup> min) or greater
<b>Compressed Air Pressure, Minimum</b>	60 psi (414 kPa)
<b>Natural Gas Pressure (Min/Max Range)</b>	4 - 7 in WC (1.0 - 1.7 kPa)
<b>Natural Gas Caloric Content, Minimum</b>	1000 BTU/ft <sup>3</sup> (37 MJ/m <sup>3</sup> ) or greater
<b>Propane Gas Pressure (Min/Max Range)</b>	11 - 13 in WC (2.7 - 3.2 kPa)
<b>Propane Gas Caloric Content, Minimum</b>	2500 BTU/ft <sup>3</sup> (93 MJ/m <sup>3</sup> ) or greater

# Power Specification

Loring coffee roasters can be built to accommodate a wide range of electrical configurations. To determine which Loring topology matches your facility's supply, the customer should engage a licensed electrician to perform a site survey, in order to provide the following information.

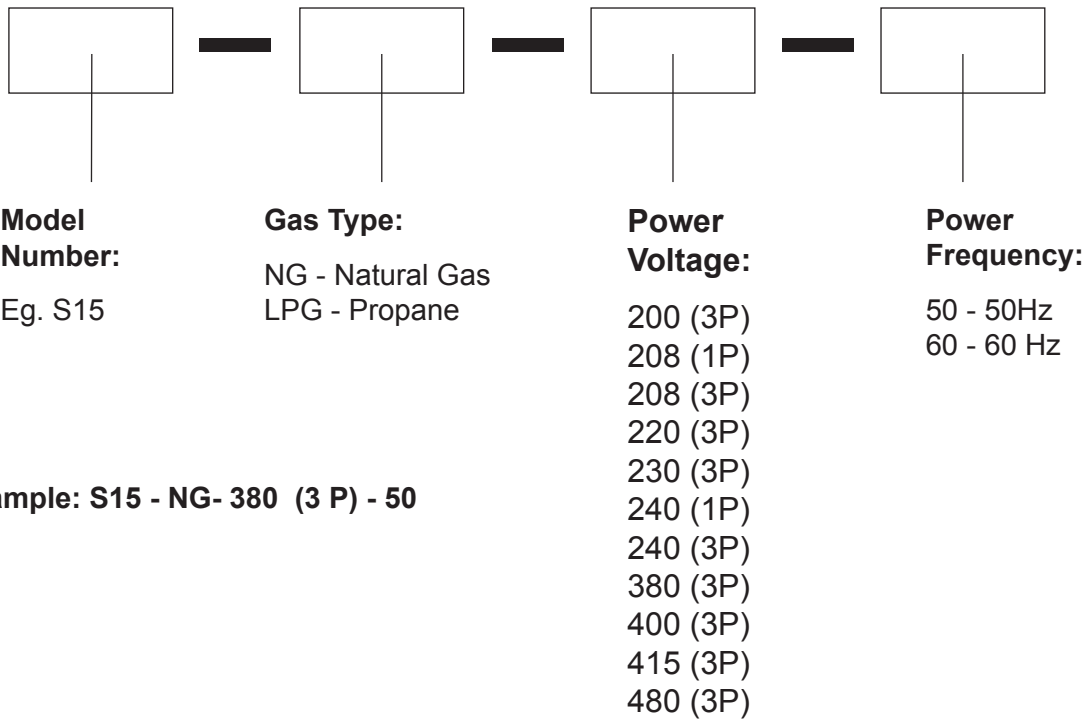

**Example: S15 - NG- 380 (3 P) - 50**

## Supply Voltage Combinations

For example, a typical U.S. installation might be 208 VAC, 3-phase, at 60 Hz.

This equates to a specification of 208 (3P) - 60

A typical installation in Europe might be 400 VAC, 3-phase, at 50 Hz.

This equates to a specification of 400 (3P) - 50

On the Product Specification Form, the customer has the option to choose among some commonly occurring configurations. However, the customer should NOT approximate by choosing the closest one if it is not an exact match.

If the customer site is not represented, contact Loring immediately for other possible configurations.

## Supply Voltages, Explained

The information under Power Specification is as follows:

- Voltage: Designates the type of power voltage at the site.
  - » The L-L number is the Primary or Line-to-Line voltage.
  - » The L-N is the Secondary Line-to-Neutral voltage.  
Note: A Neutral wire is no longer required for Loring Roasters.
- Number of Phases: The Number of Phases represents the number of Line-to-Line phases. This is either 1P or 3P, indicating single phase or three phase respectively.
- Wiring Topology: The type of circuit. Refer to *Loring Engineering Document No. 1001163* for more information.
  - » Y= Wye
  - » D= Delta
- Power Frequency: The last informational block designates the site's voltage frequency, in Hertz (Hz).

**1** **3-Phase Wye**, 4-Wire; Grounded Neutral and Contiguous Ground

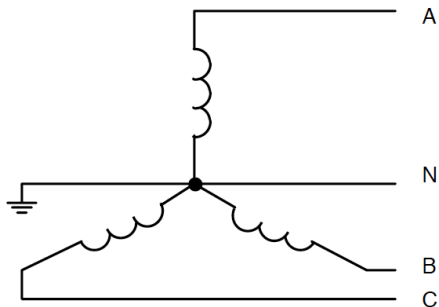

3-Phase Wye

**3** **3-Phase Delta**, 4-Wire; Grounded at Midpoint of Phase; Contiguous Ground

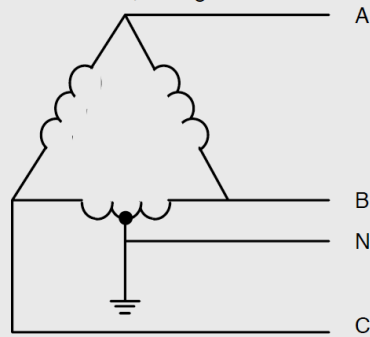

3-Phase Delta

## Supply Amperage

In order for the roaster to function properly, the customer is responsible for installing service to the required level of amperage as follows:

- 200 VAC – 240 VAC:
  - » 1P – 30 Amps
  - » 3P – 30 Amps
- 380 VAC – 480 VAC – 20 Amps



# Dimensions and Clearances

## Overall Footprint

**Table 3. S15 Dimensions and Clearances**

S15 Dimension	Value
<b>Footprint (Roaster only)</b>	61" W x 91" L x 91" H (155 cm W x 231 cm L x 231 cm H)
<b>Clearance</b>	29" left, 36" right, 26" front, 11" in back (74 cm left, 91 cm right, 66 cm front, 27 cm back)
<b>Roaster Height</b>	91" (231 cm)
<b>Minimum Ceiling Clearance</b>	12" (31 cm) above Stack Hat
<b>Total Ceiling Height</b>	103" (262 cm)

Refer to the *Mechanical Interface Control Document (MICD)* from Loring for further information, including CAD diagrams with construction details.

# Footprint – S15 Roaster

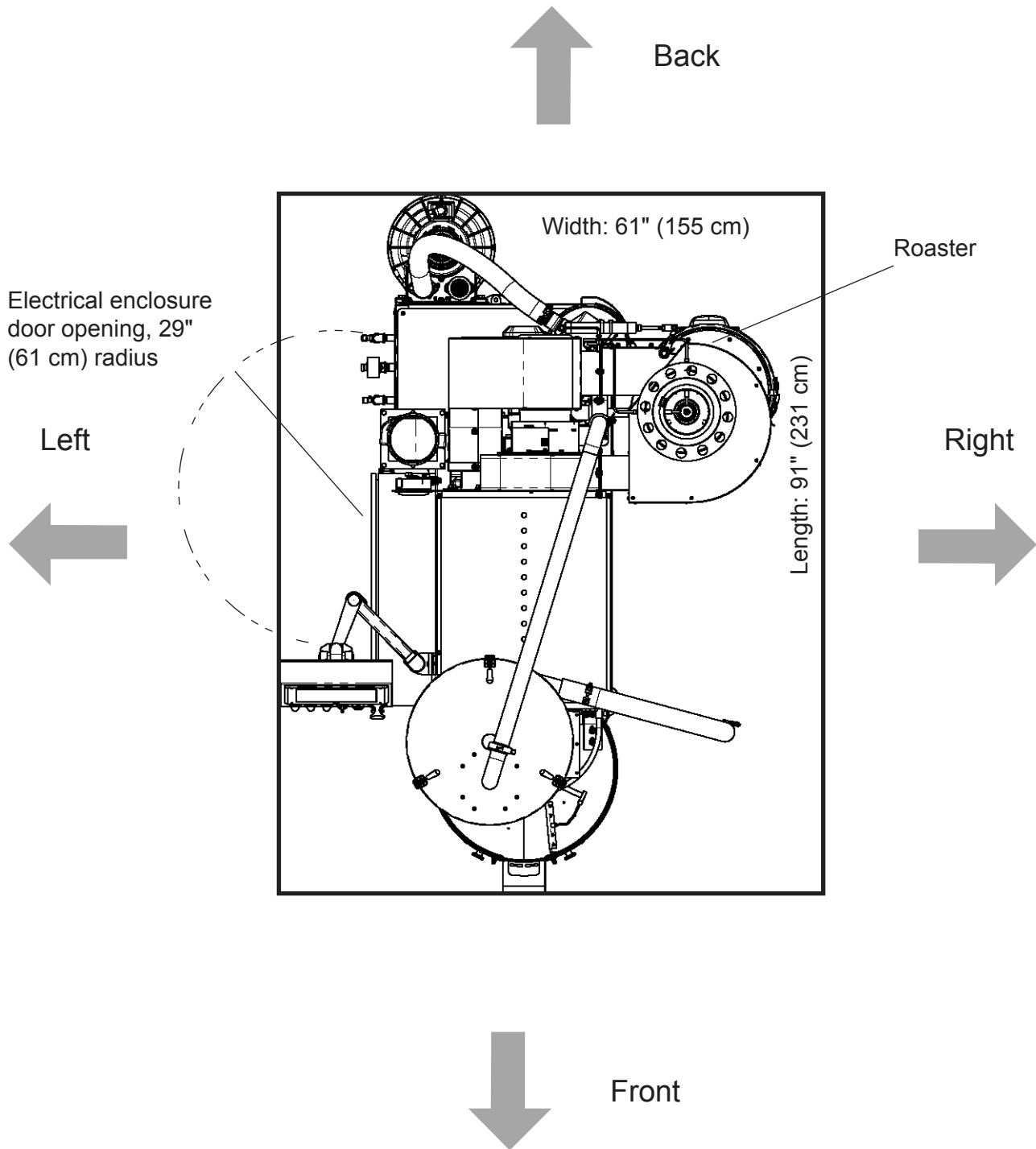

# Floor Clearances – S15 Roaster

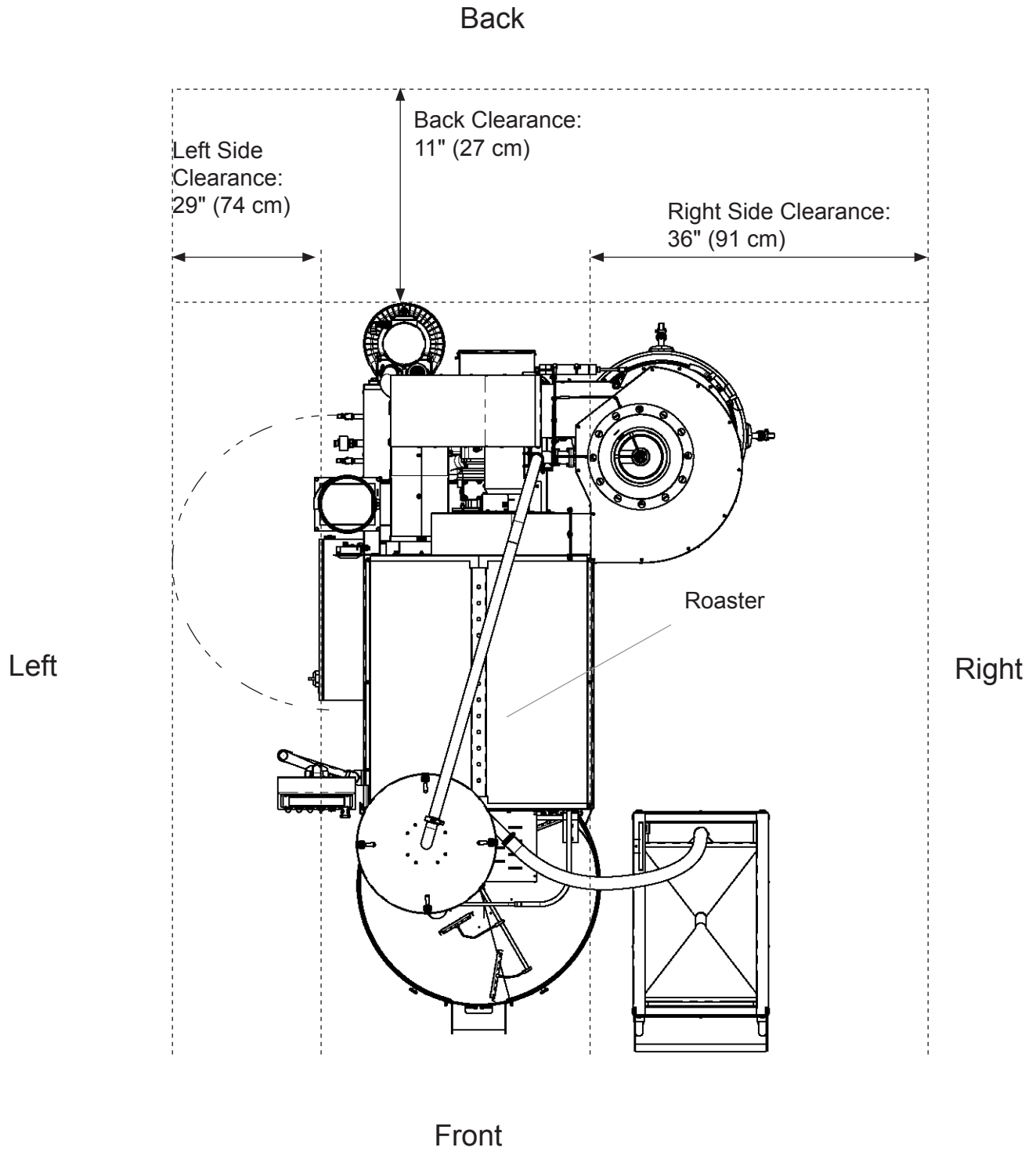

# Overhead Clearances – S15 Roaster

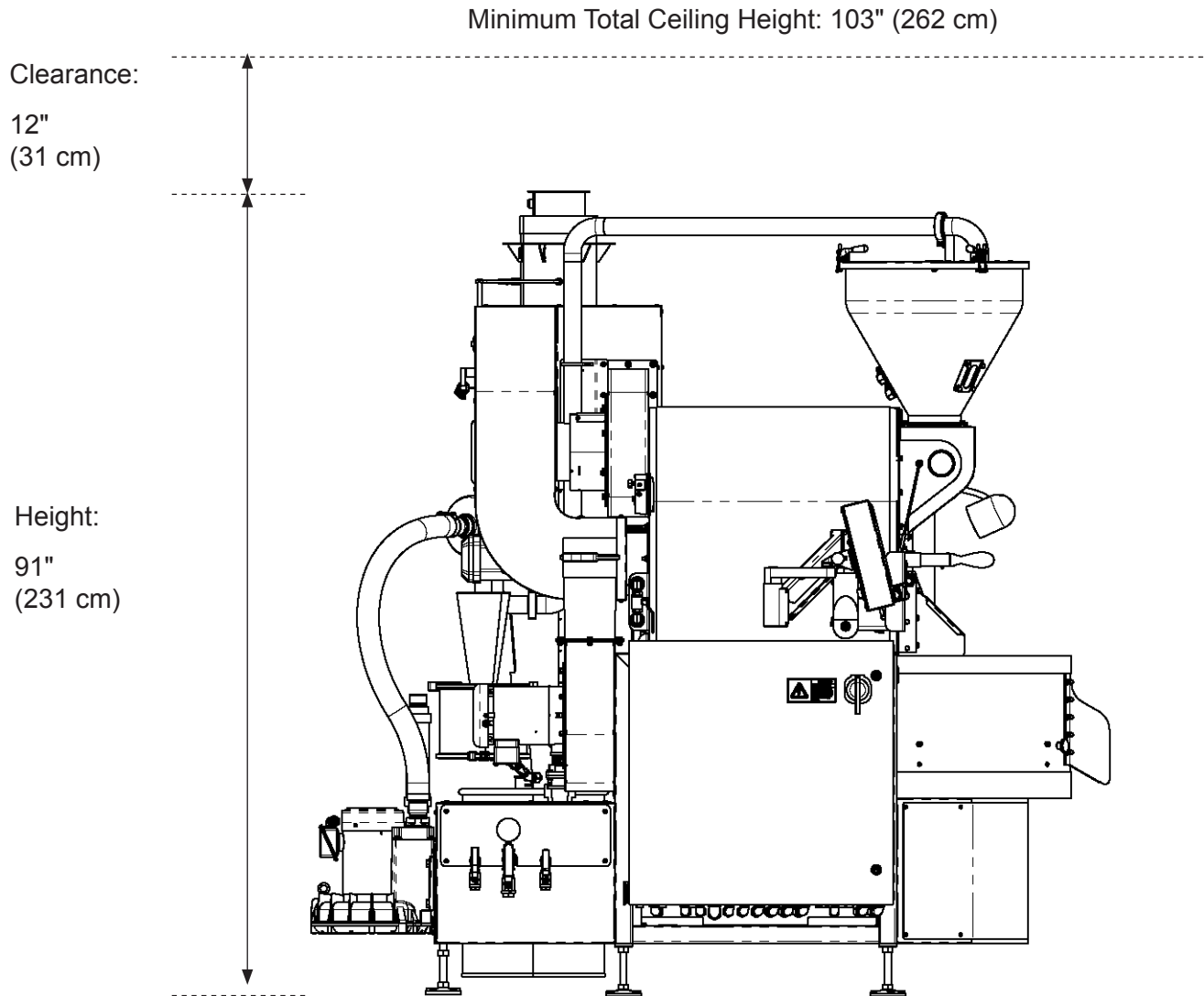

Overhead clearance should accommodate the roaster plus a minimum stack height. This clearance is also necessary for routine maintenance, as well as providing room to maneuver during installation.

# Footprint - S15 Roaster Feet

For dimensions of roaster feet spacing, contact Loring Support for the S15 MICD. [support@loring.com](mailto:support@loring.com)

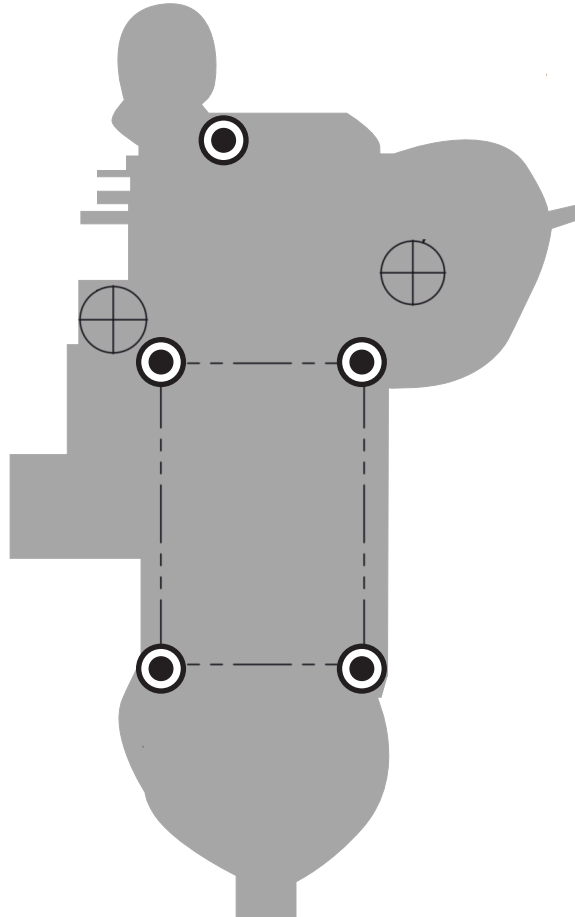

The roaster rests on 5 Roaster Feet, which support the entire weight of the roaster and allow for leveling on uneven floor surfaces. The floor must be able support the concentrated weight.

Note that total system weight may vary depending on options selected. The S15 roaster alone weighs 1573 lb (714 kg). Most of this weight is concentrated in the 4 Roaster Feet that are under the roaster body itself.

# 45-Degree Vent Kit

The 45-Degree Vent Kit is an optional 2-piece component set for the Cooling Exhaust Vent that acts as an extender. It provides additional range for positioning the exit point, including rotating around the roaster attachment point, and can be removed to facilitate cleaning of the Cooling Vent.

This kit is a special order item. If needed, it is shipped with the roaster in the Accessory crate.

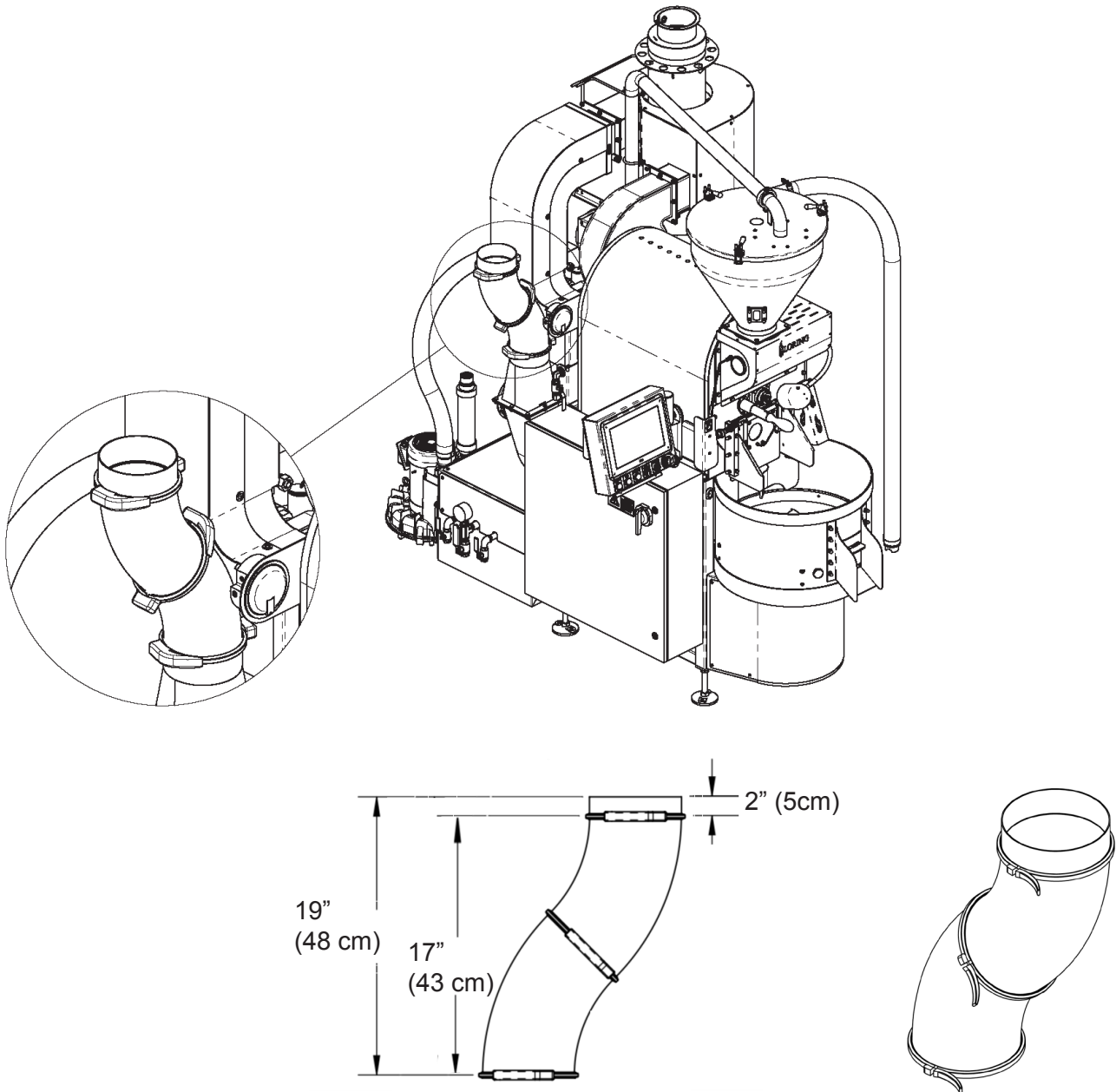

# 45-Degree Vent Kit Rotation

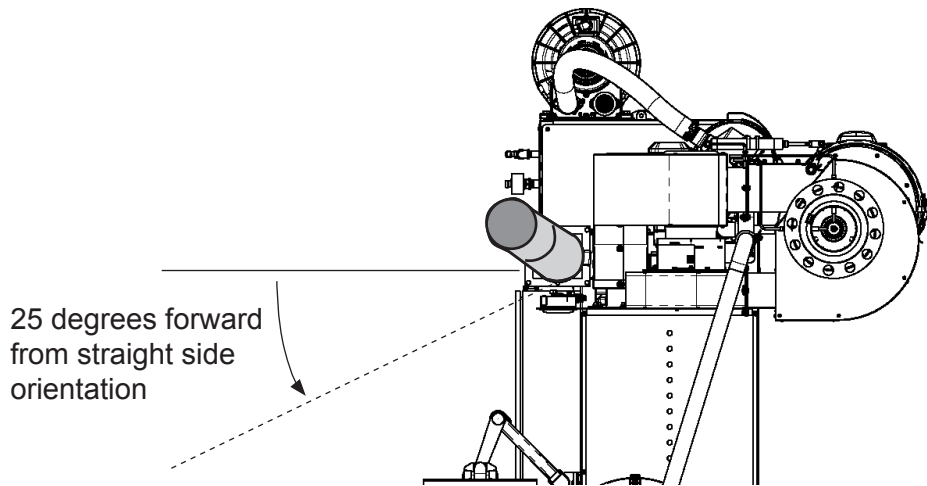
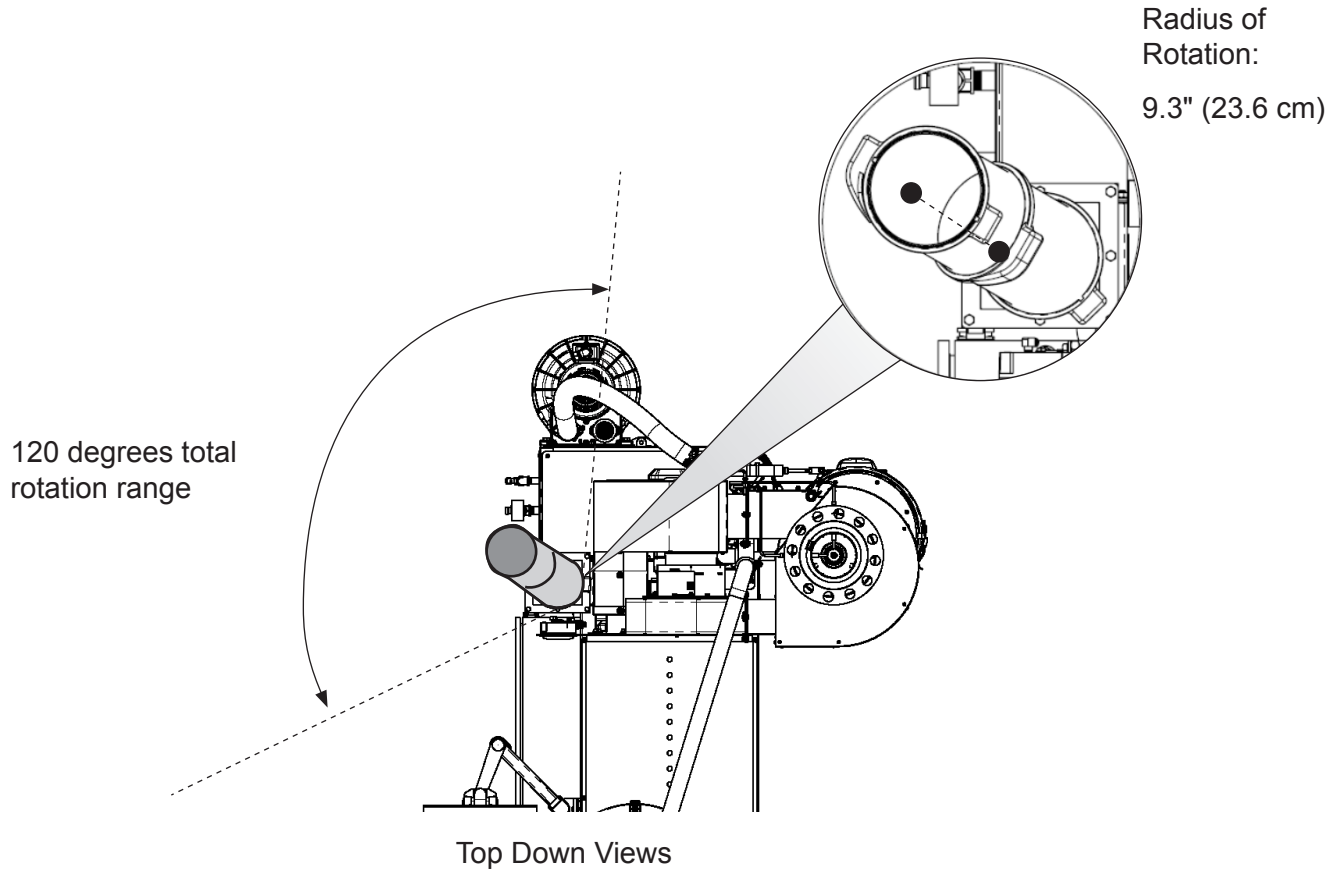

# Space Planning

## Indoors



Locate the coffee roaster in an area that is protected from the elements and from water intrusion. The area does not need to be a fully conditioned space.



## Floor

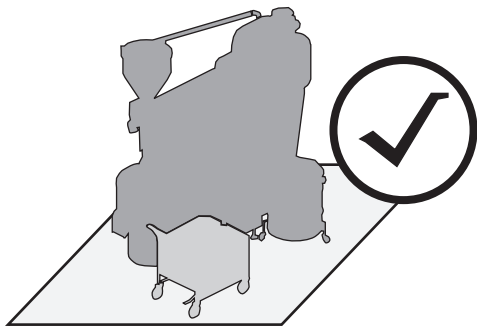

Flat and Level

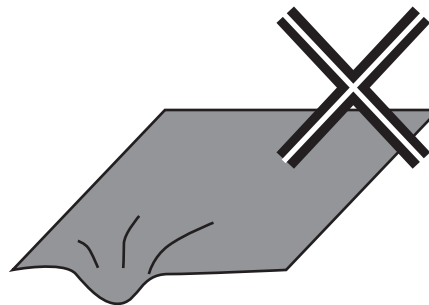

No Soft Spots

Place the roaster on a flat, level, and firm surface such as hard wood or concrete. The floor should be strong enough to support the total system weight of the roaster and all supplemental equipment.



**WARNING:** Do not place the roaster on a soft or unstable surface.



**CAUTION:** Use care when transporting the equipment over bumpy or uneven flooring.



# Stack Connection Location

The ventilation stacks connect to openings in the wall or roof. An optimal location is directly above the corresponding stack connections on the roaster.

**Refer to the Mechanical Interface Control Documents from Loring for:**

- Exact dimensions and locations on the roaster.
- Stack elbow options for routing through existing openings.

Check local building codes for additional stack ventilation requirements.

Assistance with stack design is available through Loring upon request. Loring recommends engaging with a stack design consultant to create details for complex site configurations.

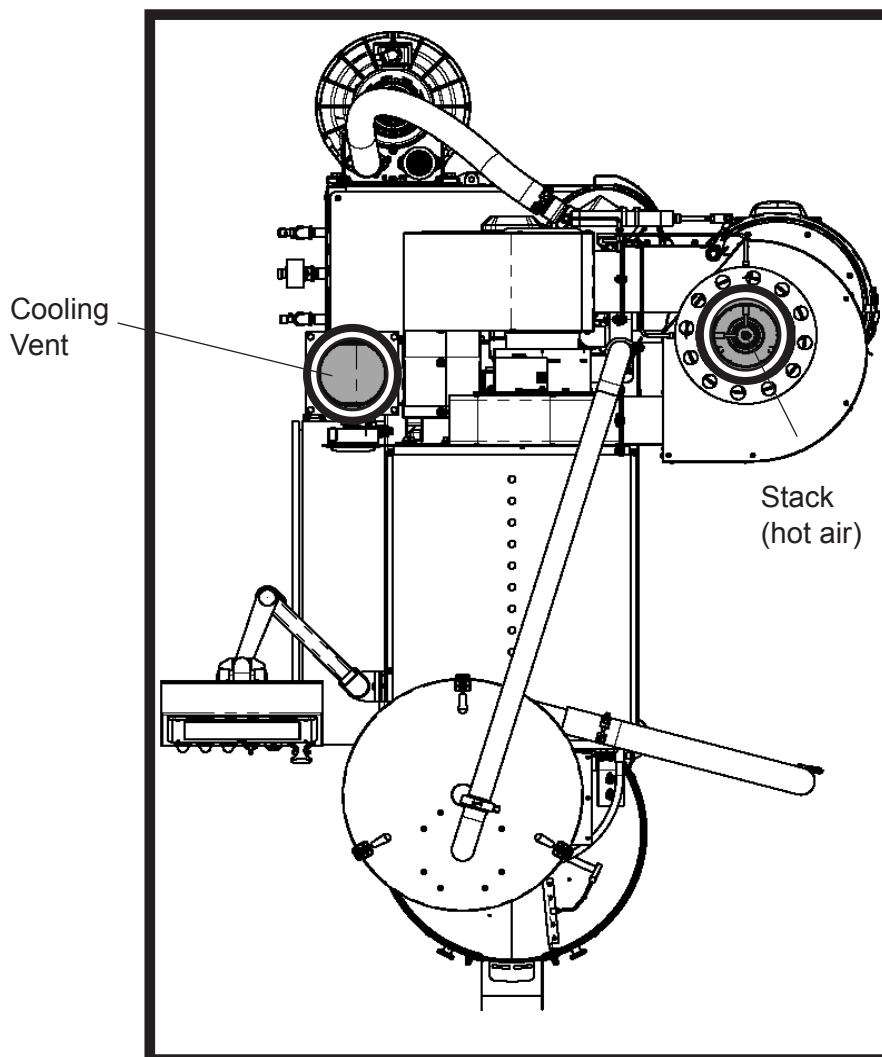

# Door Openings

Customers must consider not only the room where the roaster will be installed, but also any openings or corridors that the roaster equipment must fit through during transport and assembly.

Generally speaking, the smallest opening for the S15 (crated) 92" (234 cm) tall by 60" (153 cm) wide if the crates are side loaded onto a pallet jack, Heavy End inwards. However, under special circumstances, Loring may be able to suggest further measures to fit a piece of equipment through a tighter space.

For more information on S15 crating dimensions go to [S15 Shipping Crate on page 29](#)

## Minimum Recommended Door Opening for S15

For small openings, load crate sideways onto pallet jack

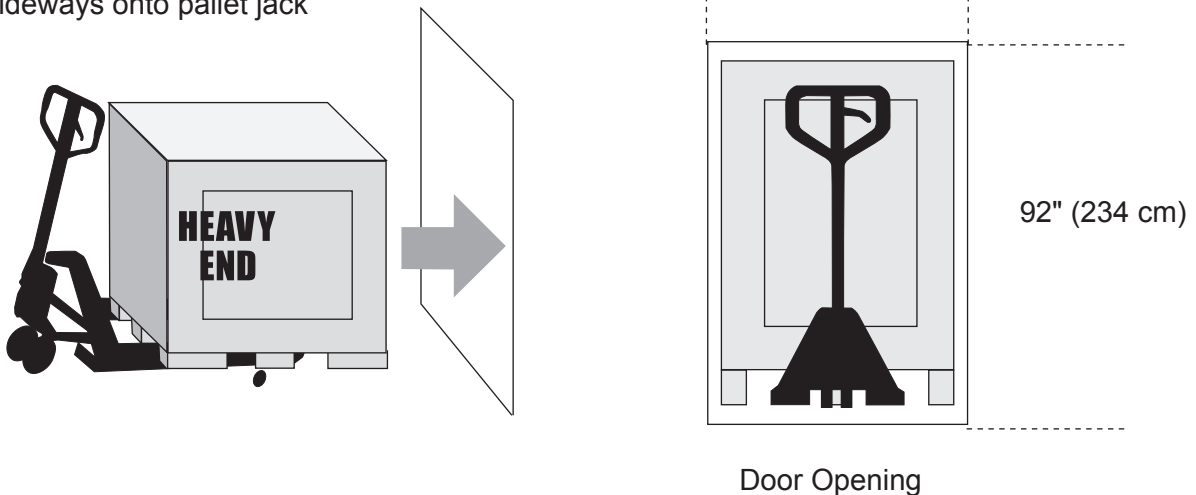

### Crate Handling Dimensions:

- Wide 51" (130 cm)
- Long 99" (251 cm)
- Height 89" (226 cm) + 3" (8 cm) for pallet jack
- Weight 1985 lb (900 kg)

# Local Codes

Local building codes and regulatory standards may require additional steps during construction and installation in areas such as seismic reinforcement or air quality. Allow sufficient time to address these requirements, including steps for mitigation if needed.

# Utilities

A licensed professional should evaluate the utility services at the installation site with the minimums shown under the Specifications section, and test that each utility meets the listed requirements. For example, if actual gas pressure is lower than rated, the roaster will not function properly.

It is important to verify that this information is correct, because the roaster will be configured to match what is available at the site. For example, some 220V AC electrical outlets are actually 230V. Note also if the gas supply is propane or natural gas.

# Room Size and Ventilation

If the roaster is located in a small, sealed room, the air outflow from the hot air and cooling air vents can create negative air pressure inside the room. Additional air intake may be needed. Refer to the Specifications section of this manual for more information.

For the S15 roaster, the total air intake flow rate is the combination of the Hot Stack Max Flow (Peak Air Cool) and Cooling Vent Max Flow from [Table 1. S15 Basic Equipment Specifications on page 9.](#)



# Low Ceiling

For rooms with low ceilings, the stack opening should be bigger than stack to allow air space for cooling, and so radiant heat can dissipate. Refer to local code requirements for the amount of space to allow. Radial stack clearances may differ based on stack manufacturer’s installation requirements. Additional rain proofing measures may be required.

Contact Loring for assistance with custom configurations for very low ceilings.

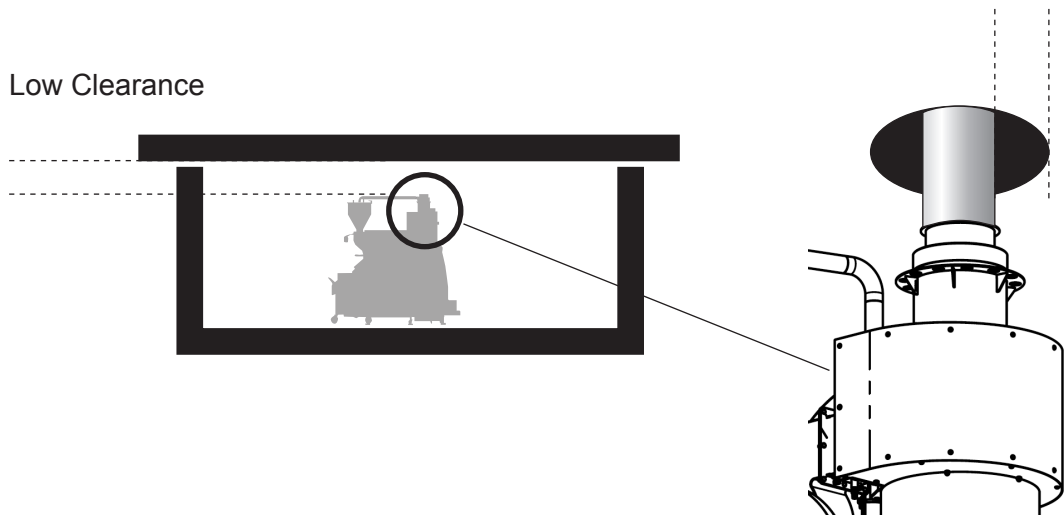

# Multi-Story Buildings

If the ceiling is taller than 15 feet, the stacks can go straight up and out of the roof, or they can bend after a certain height and exit the wall instead. This height may vary based on local regulatory requirements.

During roaster operation, air from the Hot Stack is a continuous 1400 degrees F (760 degrees C), and can get as hot as 1500 degrees F (816 degrees C). Check local code requirements on wall openings for hot air ventilation. Some municipalities may not allow hot air to be vented directly onto a sidewalk or pedestrian walkway.



# Workflow Space

Workflow refers to the smooth operation of one or more personnel within the same physical space. Both access and lighting should be considered. Some of the main access areas are shown below from the top down. Note that some controls are at eye level, while others are at floor level.

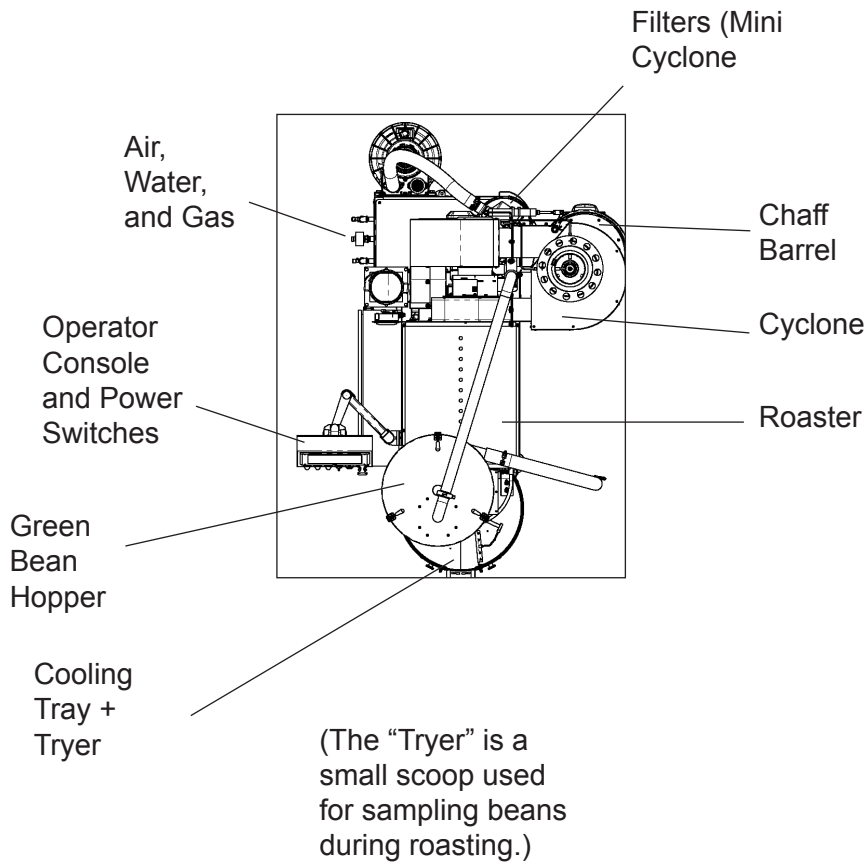

The tasks comprising daily roasting operations include:

Beans In, Beans Out. Roasting requires several points of access:

1. Load green beans into the Green Bean Cart in green bean storage area.
2. Move Green Bean Cart over to roaster, and connect the Green Bean Hopper Vacuum Hose.
3. Go to the Operator Console Touchscreen (operator interface) to initiate a roast cycle. This includes vacuum-loading the green beans from the Green Bean Cart into the Green Bean Hopper above the roaster.
4. During roasting, the operator may use the Tryer (a small sampling tray) to periodically inspect bean samples. After roasting, the beans are ejected into the Cooling Tray. The Cooling Tray is emptied and the roasted beans are transported to the next processing area.

Moving Parts. Other tasks require additional points of access:

5. On the right of the roaster, the Chaff Barrel must be removed and emptied, sometimes several times a day.
6. Periodically, the filter in the back by the Mini Cyclone must be replaced.
7. In the event of ignition problems, the operator may also use the Cyclone's Sight Glass to view the interior of the Cyclone.
8. The utility valves for air, gas, and water may be shut off at the end of daily operations.

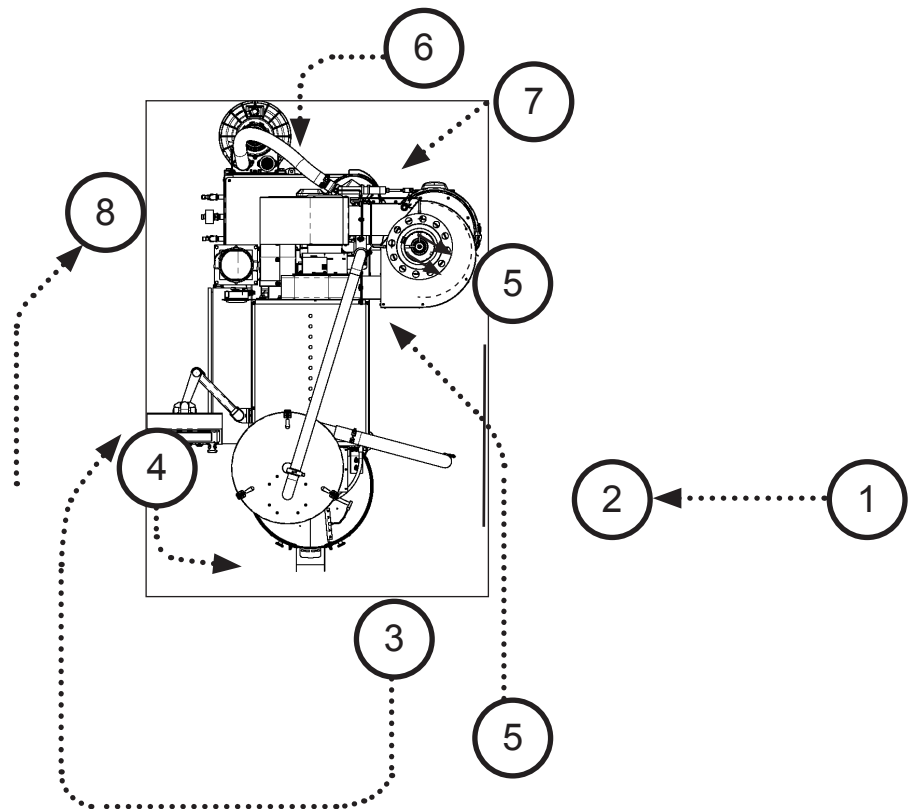

## Lighting

A minimum level of lighting should be available on all sides of the roaster, at all levels including overhead and underneath.

## Network

The roaster has the capability of connecting to an existing hard-wired Ethernet network. This allows you to monitor and control the roaster remotely from a desktop or laptop computer, email roaster data and machine fault reports, as well as upload, download and save Roast Profiles.

Customers must determine their own network configuration prior to final site commissioning, and must be able to provide this information to the Loring Field Service Technician.

# Receiving Shipment



Pallet Jack

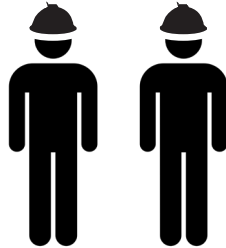

2 People



Forklift

S15 Minimum Capacity 3000 lbs

## Shipping Notes

The customer is responsible for shipping arrangements, after notification from Loring that the roaster is ready to be picked up for shipping. In particular, the customer should comply with the following guidelines:

- Be sure to state that the roaster is to travel on a vehicle equipped with air ride suspension to dampen the vibration and minimize the chance of damage during shipment.
  - » For a cross-country shipment within the United States, Loring will not load the roaster equipment onto a trailer that does not have air ride suspension.
  - » For domestic shipments, request a nose / front load in order to minimize loading and unloading at multiple terminals along the way, which will reduce the opportunity for potential damage.
- Overseas customers are advised to use a Full Container Load (FCL) shipment as this will minimize the amount of transfers and handling by others.
- Handle the crates according to markings on crate for “This Side Up” and “Heavy End”.
- For safety, use 6’ forklift extensions.

Shipping the roaster according to Loring’s guidelines is required in order to maintain product warranty.



# S15 Shipping Crate

The S15 Roaster is shipped to domestic and overseas destinations in a single crate.

Crate dimensions and weight:

Length 99" (251 cm) Width 51" (130 cm) Height 89" (226 cm) Weight 1985 lb (900 kg).

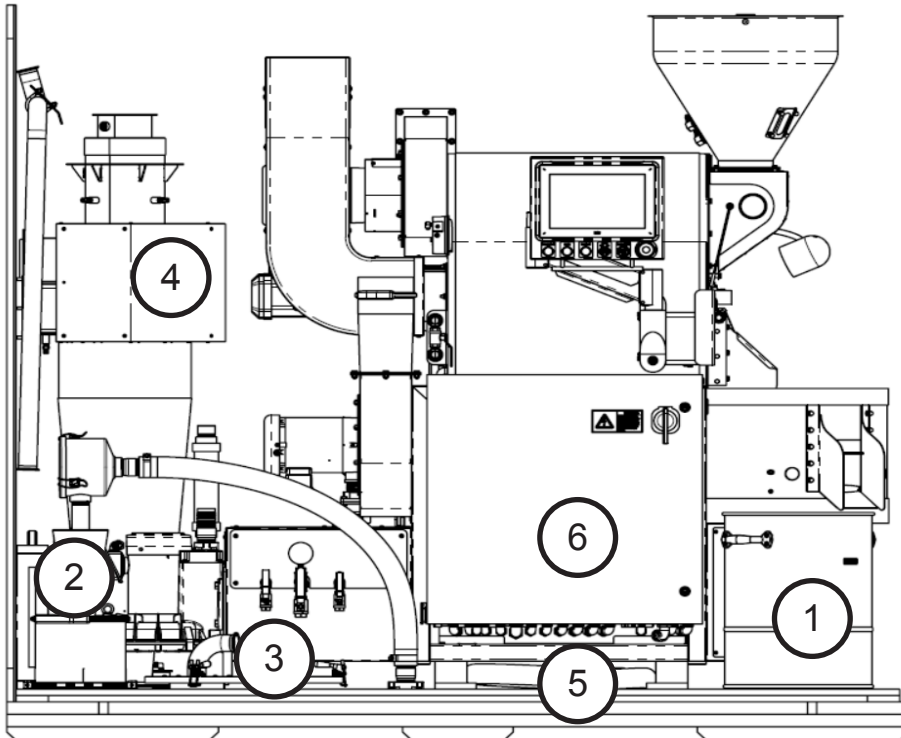

## Items included in the crate

1. Chaff Barrel
2. Mini Cyclone
3. Green Bean Hopper Lid
4. Cyclone
5. Green Bean Vacuum Hose
6. Electrical Panel
7. Green Bean Hopper
8. Vacuum Tube (Attached to side wall).

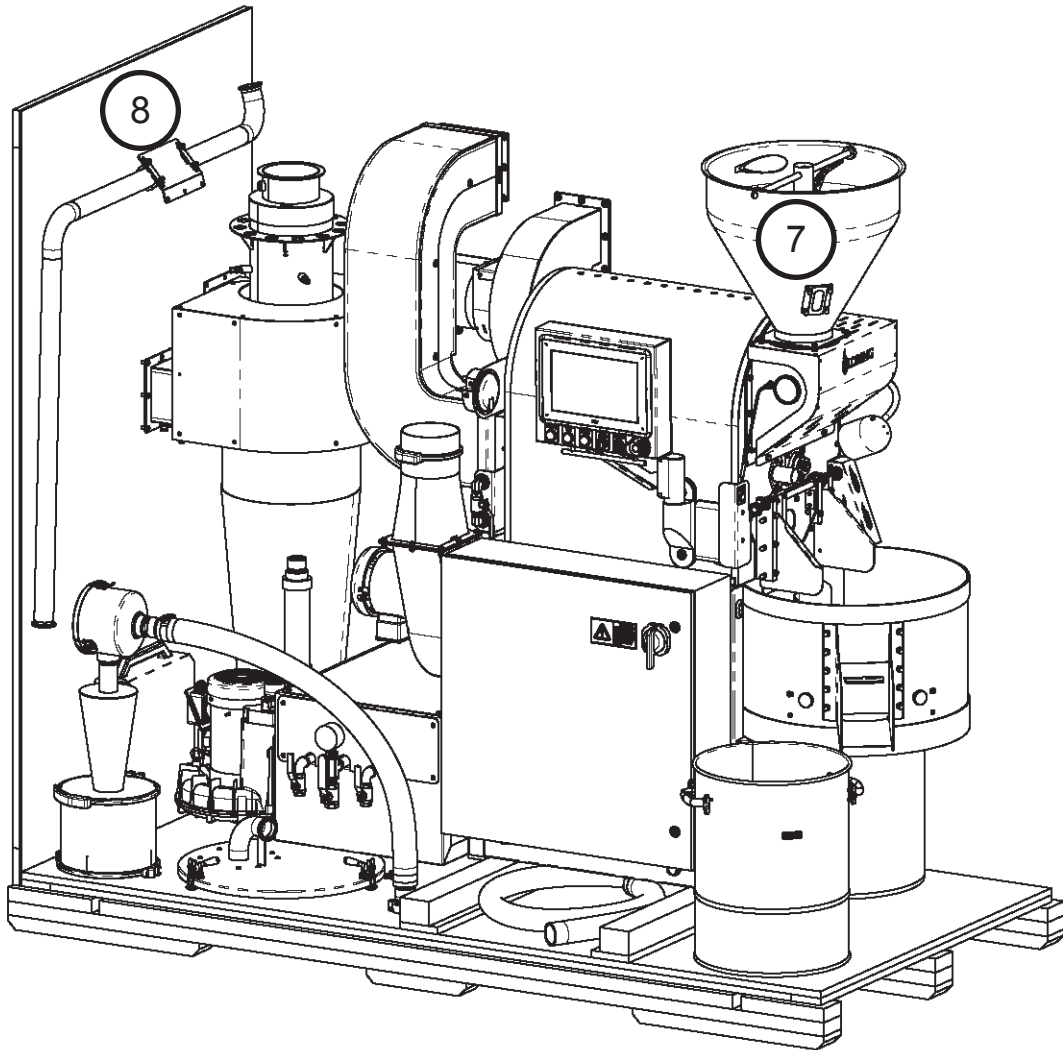

# Lifting and Moving the Roaster

## Off-Loading

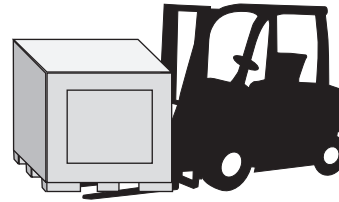

Use forklift rated for weight of crate + pallet

## Transporting

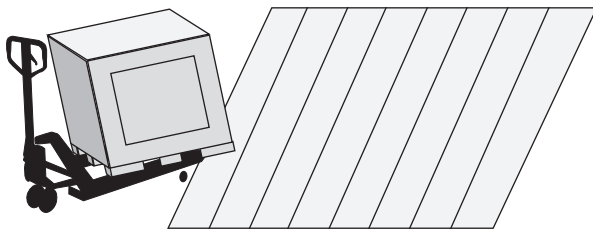

Use pallet jack for smooth surfaces

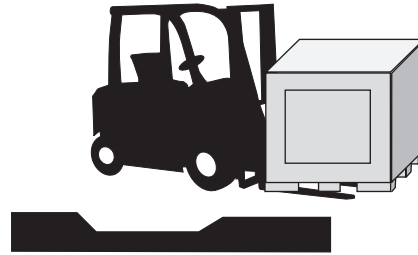

Use forklift for uneven ground with level changes

## 6' Fork Extensions

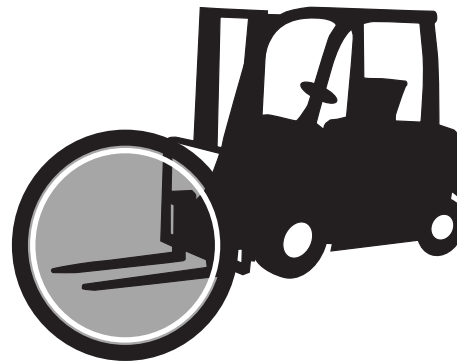
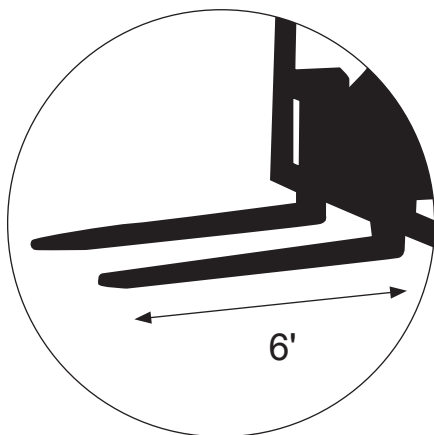

Handling

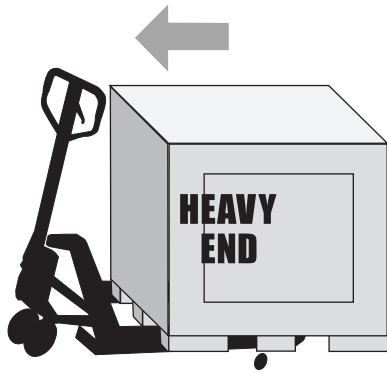

For side loading, always load "Heavy End" inwards

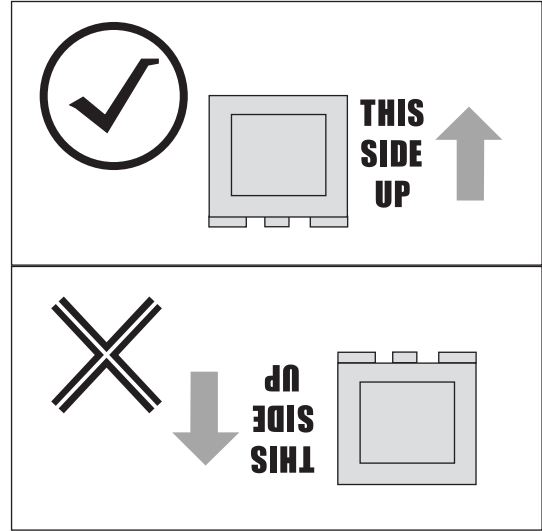

 **WARNING:** Always keep shipping crates upright during handling and storage.

Inspecting

Each crate ships with 2 shock indicators and 2 tilt indicators. Inspect crates for damage at time of delivery. Note any shipping damage on the Bill of Lading. Refer to the instructions on the indicators for detecting damage.

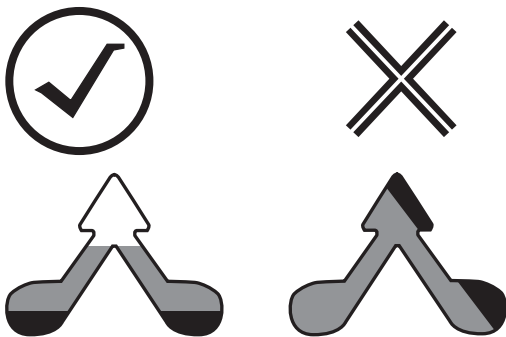

Tilt indicator shows color above line if crate has tipped

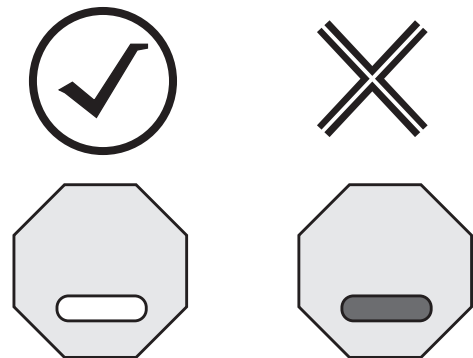

Shock indicator changes color if crate has been dropped or impacted

### Opening

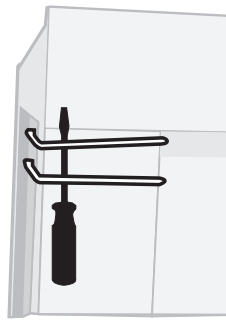

Open crate using the clips provided

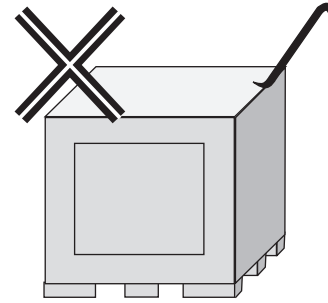

CAUTION: Do not pry open the shipping crates.

### Transporting



Do not load "Heavy End" out, as crate may fall.

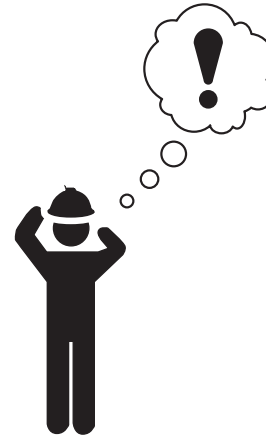

WARNING: Do not drop the roaster.

# Next Steps

After confirming the shipping date with Loring, the customer should:

1. Review the *Assembly and Installation Guide* and the *Mechanical Interface Control Documents* (MICDs), available from Loring.
2. Provide the roaster model's *Pre-Installation Guide*, the *Assembly and Installation Guide*, a copy of the customer's completed *Product Specification Form*, and the *Mechanical Interface Control Document* drawings to the licensed contractor responsible for roaster assembly and installation.

## Site Preparation Checklist

Use the following informal checklist to ensure that the site is fully prepared:

- Building meets footprint and clearance requirements for selected roaster model
- Building doorways, elevators and corridors can accommodate the roaster
- Roaster location is clearly marked
- Stack hookup locations exist and are marked
- Site Detail/Construction Drawings are completed, accurate, and available
- Destoner position has been determined and marked, if applicable
- Local code requirements are known, and have been addressed
- Required permits have been obtained
- Both the moving equipment and the final installation location can handle system weight
- Air, Gas, and Electric Utilities have been measured and verified to be within required ranges

# Gas and Gas Supply

## Gas Connection Planning

Loring roasters can be fueled by either natural or propane gas. The gas supply pressure is the same for each roaster, but the gas volume is different between them.

Gas connections to the roaster must be made by a licensed contractor in accordance with all applicable local and regional regulations regarding installations of this type. It will be the responsibility of the contractor to not only be sure that the connections meet local code guidelines but also will supply the BTU/HR demand of the roaster. Improper connection type and pipe size will cause the roaster to perform poorly, potentially rendering it unusable. The gas contractor will be able to verify the potential BTU/HR of the supply system he installs based on pipe size, length, path and available pressure.

Provided on the utility tray of the roaster is an NPT pipe fitting, which is the inlet to the burner assembly. There is a shutoff valve provided at the roaster as well as a gauge for monitoring the incoming gas pressure.

A separate regulator may be required to feed the roaster if the upstream pressure is too high.

Multiple fittings or a long path may reduce flow, which must be taken into consideration.

It is vital to the proper operation of the roaster as well as the safety and legality of the system that proper care and planning go into the gas supply system.

## Gas requirements

### Caloric Content

In order to provide adequate roasting performance, Loring roasters require that the gas supply maintain a minimum caloric level.

- Natural gas: 1000Btu/ft<sup>3</sup> (37 MJ/m<sup>3</sup>) or greater
- Propane: 2500Btu/ft<sup>3</sup> (93 MJ/m<sup>3</sup>) or greater

This is critical to the proper operation of the roaster. Confirm with your gas supply company that the minimum caloric content is supplied and constant.

## Operating gas pressure

In order to provide proper burner operation, it is critical that a constant operating pressure is available. Loring roasters require the following pressures to operate in all situations.

- Natural gas: 4 in.WC to 7 in.WC (1.0 kPa to 1.7 kPa)
- Propane: 11 in.WC to 13 in.WC (2.7 kPa to 3.2 kPa)

A regulator or a combination of regulators may be needed to attain the proper operating pressure.

## Propane Fuel Installation Specifications

BTU minimum requirements of the Loring S15 roaster.

S15 Falcon requires a 130,000 BTU/hr (33K kcal/h) gas supply.

Note: These are peak BTU requirements and the average can be less, based on usage.

BTU delivery is based upon 11" water column (WC) (2.7 kPa) dynamic flow with a maximum of 13" WC (3.2 kPa).

### Components of a Propane System:

- Propane Tank(s)
- 3/8" (0.95 cm) x 3' (91 cm) long flexible gas line(s) (hog-tail, depending on how many tanks are in the manifold)
  - » POL TEE(s) if making a manifold
  - » Additional 3/8" (0.95 cm) x 3' (91 cm) long flexible gas line(s) (hog-tail, depending on how many tanks are in the manifold)
- Hi Pressure Regulator 10 PSI (70 kPa)
  - » Sometimes an additional 2 PSI (14 kPa) regulator is required
- Low Pressure Regulator 11" WC (2.7 kPa)
- Gas Pipe properly sized for distance between regulators and BTU/hr requirement
  - » Flexible gas line 3/4" (1.9 cm) x 3' (91 cm) for S15
- Gas Meter (sometime required to meet Permit Conditions)



# Natural Gas Installation Specifications

BTU minimum requirements of the Loring S15 roaster.

- S15 Falcon requires 130,000 BTU/hr (33K kcal/h) gas supply

BTU delivery is based upon minimum 4" water column (WC) (1.0 kPa) dynamic flow with a maximum of 7" WC (1.7 kPa).

## Components of a Natural Gas System

- Utility Company supplying Natural Gas to your building
- Gas Regulator(s)
- Gas Meter
- Plumbing to Appliances

## Recommended Gas Supply System:

Gas supply to the outside of the building is always higher than the working pressure and needs to be regulated according to the specific demand.

The distance from the meter to the roaster will determine if more than one regulator is needed. If a first and second stage regulator is required, typically the first regulator is set for 2 PSI and the second regulator is set for working pressure of 4" to 7" WC (1.0 to 1.7 kPa).

Meter and regulator must be designed to handle 130,000 BTU/hr (33K kcal/h).

Second Regulator or Working Pressure Regulator must be less than 100 feet (30.5 m) and more than 10 feet (3 m) from the roaster to reduce higher pressure to the minimum working pressure of 4" WC (1.0 kPa) to maximum 7" WC (1.7 kPa).

Recommended Natural Gas Working Pressure Regulator: Sensus 143-80-2 with ½" (1.3 cm) orifice and Blue Spring with appropriate pipe inlet and outlet size. After installation, adjust working pressure of 5" WC (1.2 kPa) to 8.5" WC (2.1 kPa).

# Installing the Vent Stack

Exhaust gases are produced during the roasting process that need to be vented to the atmosphere. There are two sources of exhaust gas. Hot gas (products of combustion) through the cyclone assembly passes up into the “Hot Stack.” Also, air is drawn through the hot beans in the cooler tray to cool them is passed up the “Cooling Stack.”

To keep rain out of the stack, caps must be attached at the exit of the stacks and any joints in the stack ducting must also be designed to keep rain out.

In general, a survey of the building will be made to determine where to position the roaster and how then to position the stack ducting to vent exhaust gases to the atmosphere. In the following pages are examples of common ducting configurations and techniques to provide ducting flexibility using the 45-degree vent kits.

## Hot Stack

The Hot stack connects to the top of the cyclone to the “Stack Hat” which is provided with the roaster. From this stack hat, you can attach to the customer supplied stack by welding, clamping, screwing, riveting and caulking. The best connection is with a V-Band. No amount of leakage is acceptable.

The stack must be supported above and not by the roaster. Also, the effects of thermal expansion should be taken into account so that thermal growth does not put force on the roaster.

## Cooling Stack

The cooling stack will attach to the top of the cooler housing outlet, typically with a V-Band to a flange fitting, or at the preference of the customer and contractor may be attached by a variety of other methods. It is important that this connection is sealed but also easily removable for cleaning. The roaster may have the optional 45-degree offset kit, which does not alter the connection type, but allows for an easily removable and cleanable section.

## Roaster Placement

The roaster should be placed on a level, solid and cleanable work surface. The ball swivel mount leveling feet will allow the roaster to be leveled after it is put into position.

There may be regulations in your area which will mandate surface structure, anchoring, and minimum clearances.

## Getting Help

You will need to refer to your ventilation contractor for the preferred method of attachment. In turn, your ventilation contractor will need to be sure to comply with all applicable local and regional regulations regarding installations of this type.

## Connection to be avoided

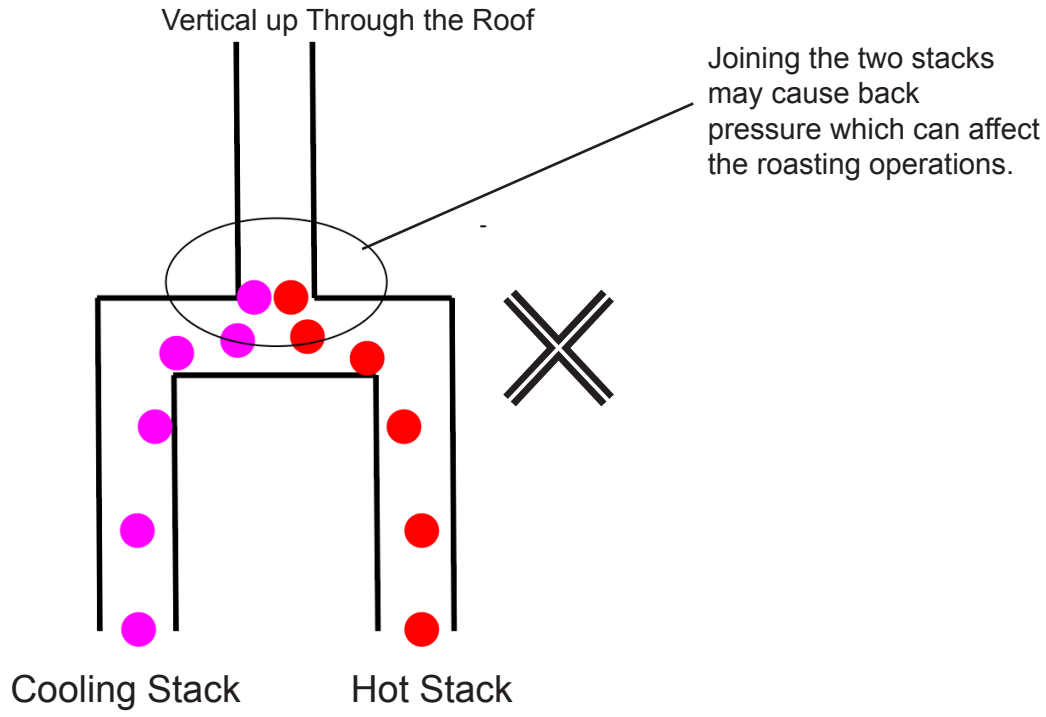

# Vent Stack Configurations

## Vertical up Through the Roof

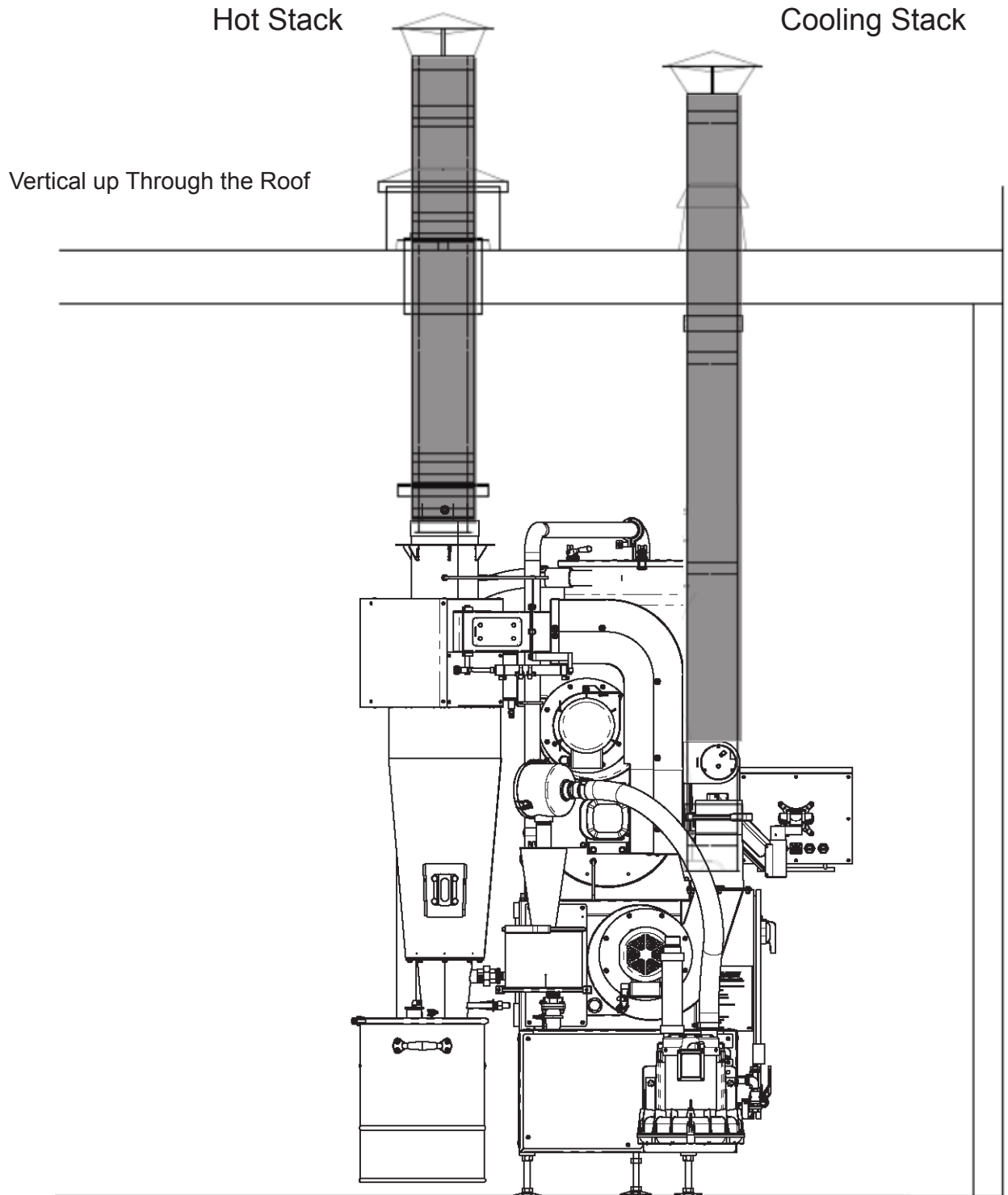

## 90 Degree Horizontal Through the Wall

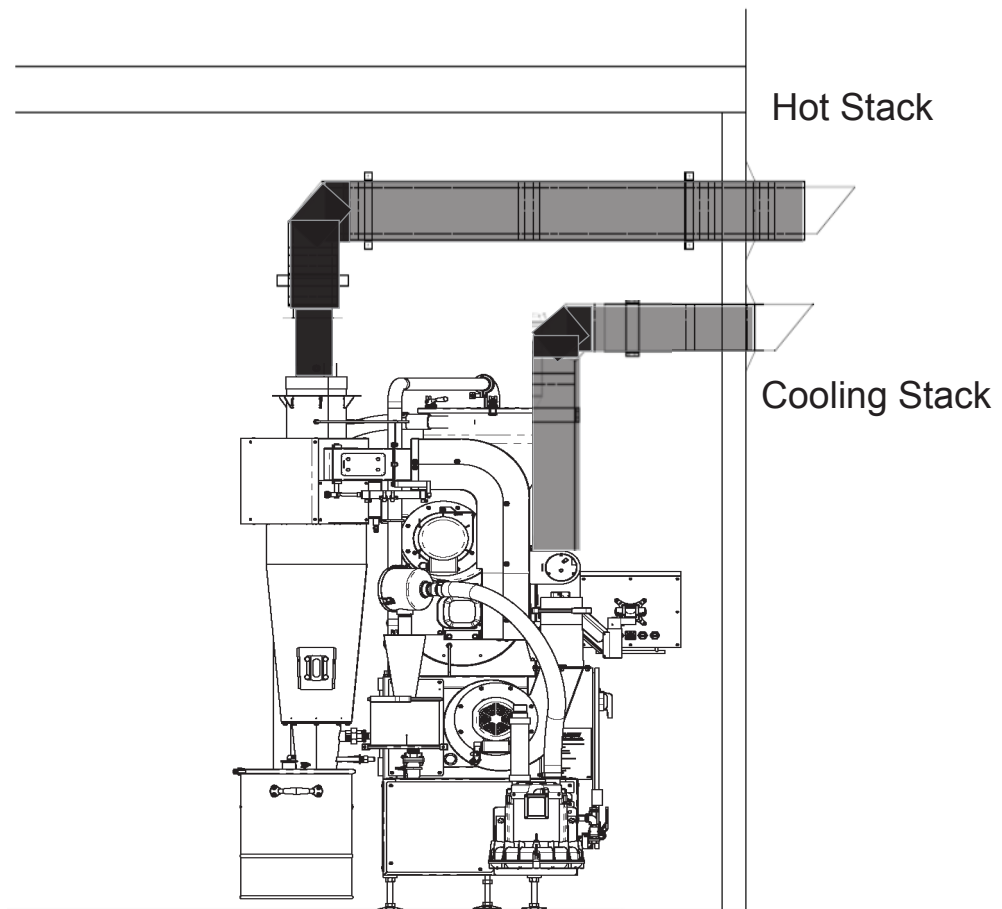

## Vertical with 45 Degree Vent Kit

Hot Stack

Cooling Stack

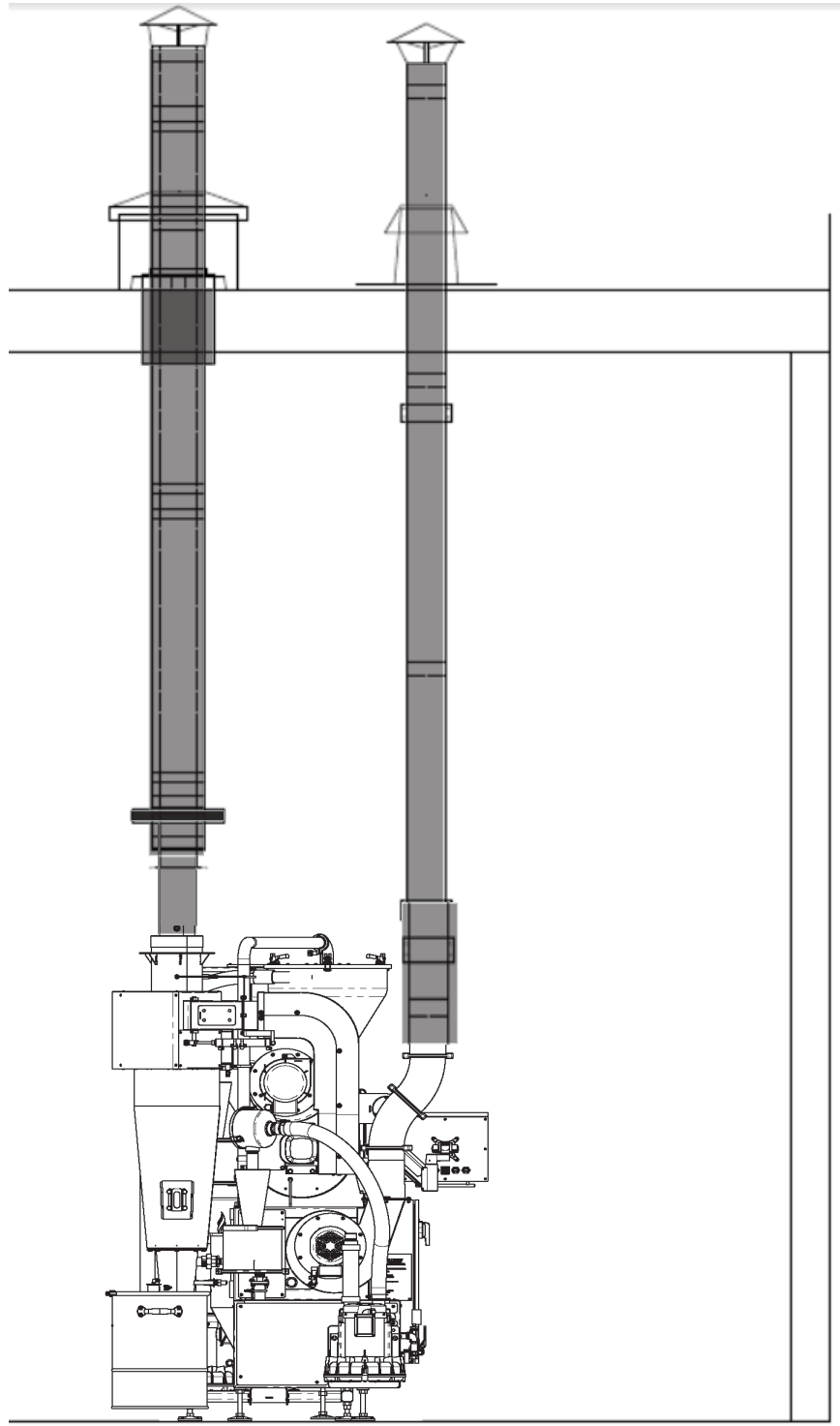

## Extended 45 Degree Extension on Cooling Duct

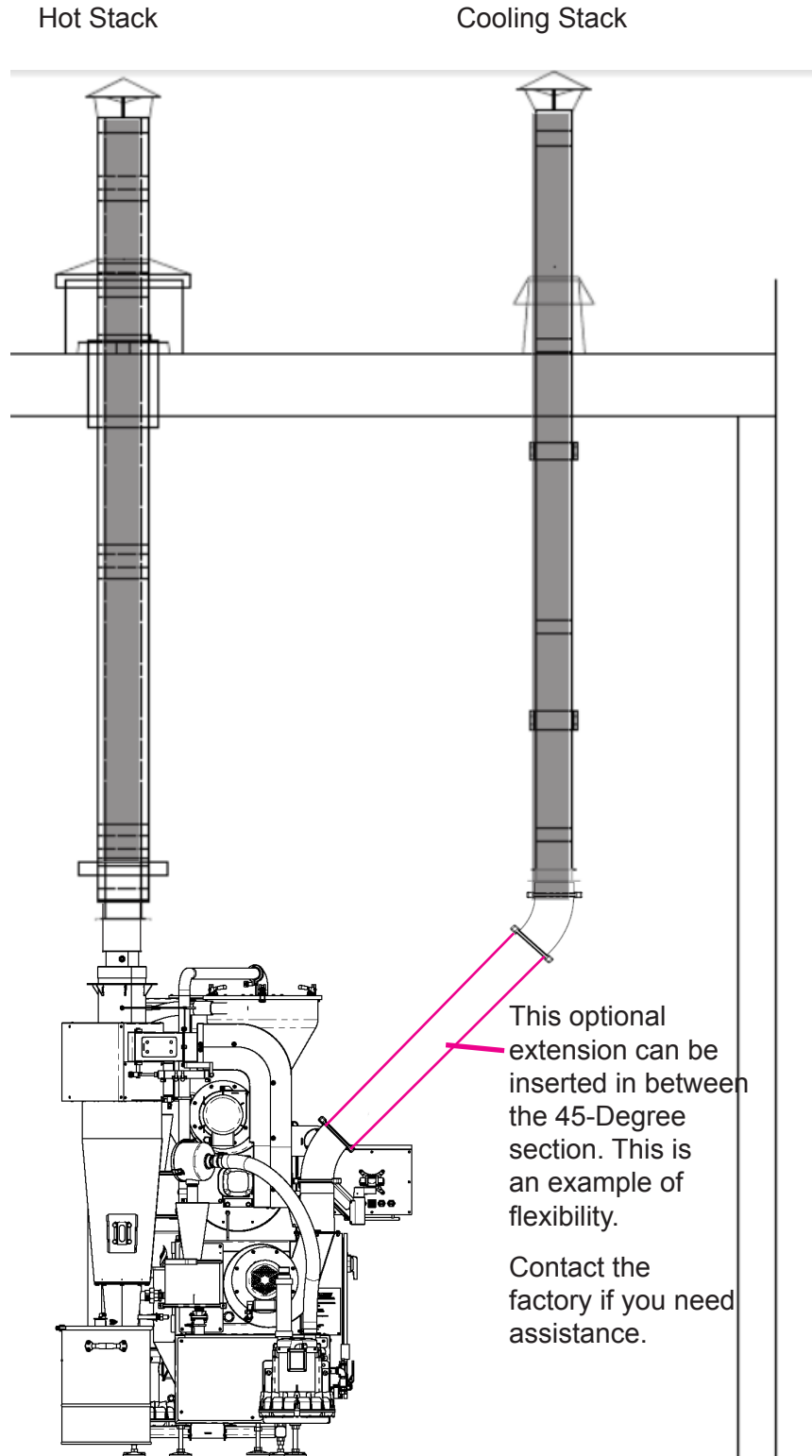

# Adjusting Roaster to the Vent Stack

Using a Standard 45 Degree on Cooling Duct

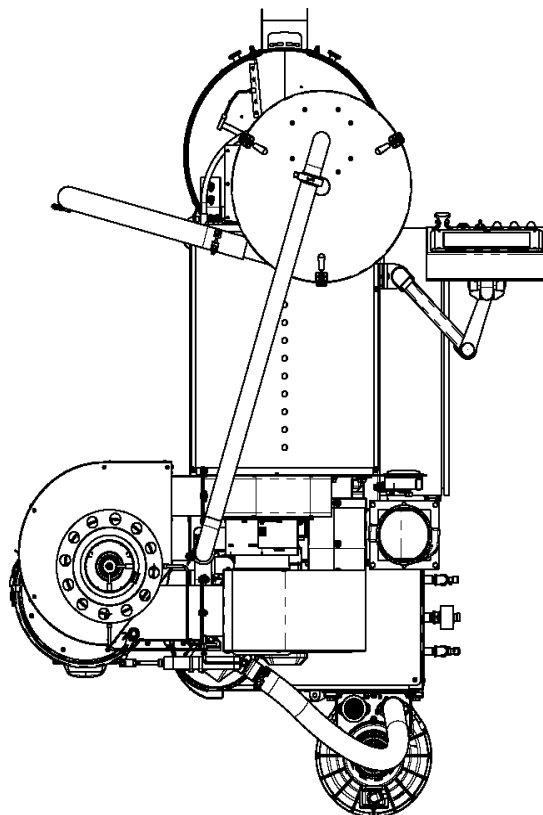
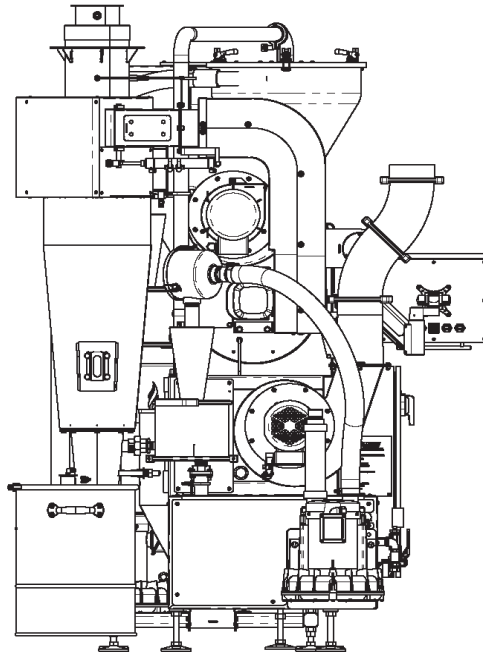



This page intentionally left blank.

# Manufacturer Contact Information

This equipment is manufactured by:

Loring Smart Roast, Inc.  
3200 Dutton Ave #413  
Santa Rosa, CA 95407  
(707) 526-7215

For questions, please contact Loring Customer Support:

[www.loring.com/support](http://www.loring.com/support)  
(707) 526-7215 ext. 217  
[support@loring.com](mailto:support@loring.com)