



HT-KJ20Series Mini Capsule Packaging Machine

Operation Manual



Table of contents

Preface.....	4
Important Notes	5
Chapter 1 Safety Precautions.....	8
1-1 Safety (Mechanical)	8
1-2 Safety (Electrical)	9
1-3 How to operate the emergency stop button	10
Chapter 2 Outline and Specifications of the Machine	11
2-1 Outline of each process.....	11
2-2 Main technical parameters of this machine	13
2-3 Outline of the machine.....	14
2-4 Dimension of this machine.....	14
Chapter 3 Inspection and Installation.....	15
3-1 Inspection.....	15
3-2 Installation.....	15
Chapter 4 Operation	18

4-1 Precautions during operation.....	18
4-2 Operation switch and touch screen description.....	20
4-3 Operation procedures.....	29
4-4 Auto or manual/debugging operation procedures.....	30
Chapter 5 Spare Parts, Circuit Diagram and Cylinder arrangement.....	32
5-1 Spare Parts with the machine.....	32
5-2 Circuit Diagram.....	33
5-3: Cylinder arrangement diagram.....	34

Preface

Thank you for purchasing HT-KJ20 mini Capsule Packing Machine.

This machine uses prefabricated cups as packaging materials to fill and package the products.

This machine is designed with the first principle in mind to ensure the safe use of customers and is manufactured under strict quality conditions.

Please read the instruction manual carefully, and use the machine correctly and safely on the basis of fully understanding the contents.

Since we are continually improving this mini capsule packaging machine all the time, please understand that your company's machine may have some differences with the items described in the instruction manual.

During the use of this machine, if you find any problems, please contact our company.

Important Notes

1. If you have not read this instruction manual, do not operate the machine and the accompanying accessories.

Before the installation, adjustment, maintenance and inspection of the machine, and before operating the machine, the operator who uses the machine must read this instruction manual carefully, and then carry out the operation on the basis of a full understanding of the content. Operation without understanding the contents of the manual may result in personal injury.

2、 Please operate according to this instruction manual.

In order to use this machine safely and to bring out its best performance, the operator should work according to the instruction manual and pay sufficient attention when using this machine. Our company does not assume any responsibility for the consequences caused by the customer's failure to operate in accordance with this manual.

3、 Please install a safety device.

In order to ensure the safety of operators, this machine is equipped with safety devices. Please use the safety device correctly on the basis of full understanding. Serious personal injury may result if the safety device is removed while the machine is in use.

4、 Please abide by the workshop safety and hygiene management system.

Please let the operator who has read this instruction manual carefully and fully understand the content carry out maintenance, inspection and operation alone. If the operator puts his hand or head inside the machine, other personnel may maintain, inspect and operate the machine, which may result in personal injury. When it is unavoidable that more than two people must work, please determine the rules of mutual communication in advance, and make sure that all operators are safe before operating.

When using this machine, in order to ensure the safety of operators, please implement safety education and training for operators. Use this instruction manual for education, or formulate the "Safety Management System" according to the actual industry situation of the company, and abide by the routine written system.

Our company cannot manage the usage status or operator of your company's machine. Therefore, the use of this machine and the management of operators are all within the scope of your company's management and responsibilities. In addition, the company is not responsible for the use of machines or other companies' parts and accessories that we cannot directly manage.

Please thoroughly rinse and disinfect the machine parts where the product comes in contact with the filler. Your company should formulate sanitation management standards for washing and disinfection according to the products, strictly abide by and record them. In addition, if the industry or the industry has certain regulations, please comply with the regulations.

5、 Please use the voltage and frequency listed on the nameplate.

In order to use the unit safely and achieve its best performance, please use the voltage and frequency stated on the nameplate. Failure to do so may result in fire, electric shock, or damage to the machine. If the environment used does not match the description on the nameplate, please confirm with our sales staff. The company does not take any responsibility for accidents and malfunctions that occur when the usage environment and the conditions stated on the nameplate are not in conformity.

6、 Modification is strictly prohibited.

In order to avoid personal injury, our company has designed and installed various safety devices. To ensure safe use, do not disassemble or modify the safety device. In addition, without the consent of the company, do not modify the machine without permission. If the machine or safety device is modified, there is a high possibility of serious personal injury or machine damage. The company does not assume any responsibility for accidents and malfunctions caused by this situation.



7、 When the machine is discarded, please do not leave it casually.

When disposing of the machine, please dispose of it as industrial waste according to the country or local regulations, etc.

8、 Be sure to fully understand and strictly abide by the locations and contents of "Danger", "Warning" and "Caution".

There are hidden dangers in the operation and maintenance of machines. Careless operation or ignoring instructions will result in serious accidents. These marks are

recorded on the machine or in the instruction manual. Please be sure to fully understand the following contents and strictly observe them.

word of warning		content
	DANGER	Indicates that failure to comply with its contents may result in serious personal injury.
	WARNING	Indicates that failure to comply with the contents may result in serious personal injury.
	CAUTION	Indicates that non-fatal personal injury or machine damage is likely to result if the contents are not followed.



当心触电

Beware of electric shock



当心机械伤人

Beware of mechanical injuries



Beware of getting hot



no touch



be careful



Do not touch while running



Do not touch while running

9、 Be sure to confirm the sealing status of the product.

Be sure to confirm whether the sealing state of the packaged product is appropriate, whether the sealing part is clean, whether there is any defect caused by product or liquid spillage, and whether the strength of the sealing is sufficient. Please carry out strict quality inspection of the packaged products according to the industry standards of your company or the product. If any defects are found, please check and maintain the sealing device, and adjust the sealing time or temperature.

Chapter 1 Safety Precautions

1-1 Safety (Mechanical)

When developing this machine, our company designed and manufactured it based on repeated and thorough research on safety factors. However, if the operator uses the machine without sufficient knowledge, safety problems may arise. To ensure safe installation, operation and maintenance, be sure to observe the following "Warnings" and "Cautions". If you still have questions or are unclear, please consult the manufacturer and do not proceed until you receive a response.



- 1) Please do not start or operate the machine until you understand all safety precautions, installation precautions, operation procedures, maintenance and cleaning procedures.
- 2) During the operation of the machine, the operator should not put fingers, hands, head and clothes near the running parts of the machine.
- 3) Do not wear loose and fat clothes or accessories that are easily hooked on the machine for operation, adjustment, repair and cleaning. Be sure to wear appropriate work clothes and work caps. Also, wear non-slip shoes, etc. when working in a place where the floor is wet with water or oil.
- 4) Before starting the machine, be sure to confirm that the safety cover and safety guard are properly installed.

- 5) Do not adjust, repair or clean while the machine is running.
- 6) During manual operation, fine-tuning operation, or when multiple people operate the machine at the same time, please ensure the safety of the surrounding in advance.
- 7) This machine operates intermittently for the cup feeding turntable, so some mechanisms will be temporarily stopped when the machine is running, and it is forbidden to touch the machine at this time.
- 8) Do not physically touch the delivery station of the packaged finished product.



Cautions

- 1) Do not place tools, parts or other objects in or on this machine.
- 2) After adjusting the machine, do not press the running switch immediately, first press the jog switch to run the machine, and then press the running switch to turn on the machine after confirming that the machine runs smoothly.
- 3) Before running the machine, please make sure that the air supply hose is inserted into the machine and the air pressure is up to standard.
- 4) When cleaning the machine, do not spray water on the inside of the rack, the inside of the electrical box, or the upper part of the turntable.
- 5) If a strange sound or abnormal vibration occurs during operation, stop the machine immediately, clear the fault, and then restart it.
- 6) If you need to replace consumables or spare parts, be sure to use our company's products or designated products. If you want to use another company's product, please confirm with our company in advance whether it can be used.

1-2 Safety (Electrical)



Warning

- 1) When the machine is shut down due to a fault, the main power supply and air source of the machine must be cut off before inspection and maintenance.

2) When performing electrical work or replacing and maintaining electrical components, be sure to cut off the power supply and air source in advance.



- 1) Please use the voltage and frequency listed on the nameplate.
- 2) Please be sure to firmly close all the electrical box doors of the machine to prevent water from entering. Tighten all knobs after completing electrical work, adjustments and repairs.
- 3) When jogging adjustment is required, please avoid continuous jogging. If the jog is continued continuously, the mechanical parts may not be adjusted to the proper position and may be stuck and collided, resulting in overload damage to the drive motor or damage to other drive components.
- 5) The sealing heating device and the surrounding parts are easy to become hot, please do not touch it with your body.
- 6) When the machine is turned on, the machine will automatically reset. If it is found to be abnormal, you should press the emergency stop immediately to find the cause.

1-3 How to operate the emergency stop button

To make an emergency stop of the machine, press the emergency stop button. After being pressed, the unit stops in an emergency and locks in the pressed state. To operate again after troubleshooting, turn the button in the direction of the arrow (clockwise) to release the lock. Next press the start button to turn on the unit.



Press to lock emergency stop state



Turn right to unlock

Chapter 2 Outline and Specifications of the Machine

2-1 Outline of each process

HT-KJ20 small capsule packaging machine consists of three parts: suction cup device, unloading device and film suction device and heat sealing device. The turntable of the capsule machine operates intermittently, with ten stations evenly distributed on the circumference.

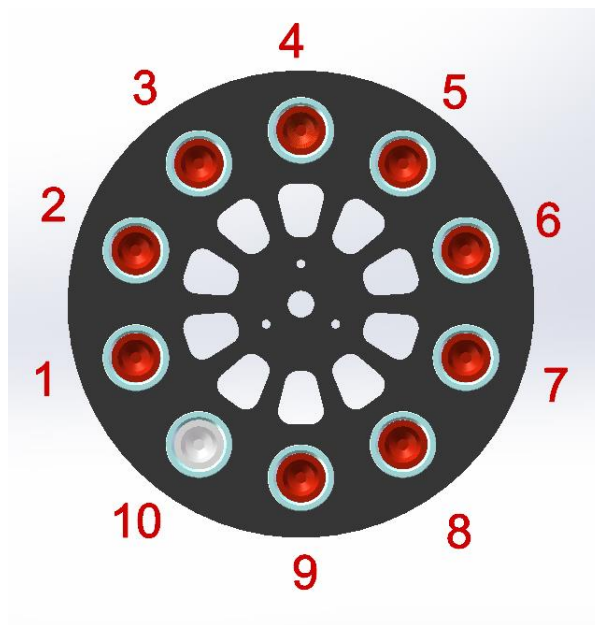

Work station illustration

- ① suction cup ② vacancy ③ detection cup ④ feeding ⑤ nitrogen filling ⑥ suction film ⑦ Film detection ⑧ heat sealing ⑨ discharging ⑩ vacancy

Turntable

- ① Suction cup station

Put the cups in the silo above the work station, there is a suction head below, and suck the cups from the top to the work station one by one.

② **Backup station**

③ **Detection cups**

There is a detection sensor under the station. In the automatic operation mode, the station behind the cup is detected to operate normally, and the station behind the cup does not move when it is detected that there is no cup.

④ **Feeding station**

The station is equipped with quantitative equipment, when the previous station has a cup signal, and the quantitative equipment is fed on the station.

⑤ **Nitrogen filling station (optional)**

According to the actual condition of the packaging material, nitrogen filling requirements may be configured, and the nitrogen filling interface and sealing plate are installed above the station.

⑥ **Film Suction station**

A film suction device is installed above the station, the film is placed in the device, and a suction cup that moves up and down is installed below the device to suck the films to the station one by one.

⑦ **Film detection station**

A detection element is installed on the station. In the automatic operation mode, when a film is detected, the next heat-sealing station operates normally, and if no film is detected, the next heat-sealing station does not work.

⑧ **Heat sealing station**

A heat-sealing device is installed above the station. When the previous station detects a film, the heat-sealing device will automatically seal.

⑨ **Discharge station**

After the cup completes all the actions, the pneumatic element transports it out at this station to complete the final action.

⑩ **Backup station**

2-2 Main technical parameters of this machine

Model and name:	HT-KJ20 mini capsule packaging machine
Mechanical speed:	25 packs/min
Actual packing speed:	12-25 packs/min (according to material condition, etc.)
Packing bag size:	cup diameter 15mm-60mm
Material filling range:	1-100g
Sealing method:	heat sealing
Total power supply:	single-phase 220V/50Hz 1kw
Machine dimensions:	820X602X1630
Machine weight:	about 1600Kg
Compressed air:	pressure 0.5-0.8MPa, air consumption about 100L/min
Installation conditions:	Temperature 10-40℃ Humidity 30-90%RH, no condensation Altitude below 1000 meters No corrosive gas, no flammable gas, no dust and iron filings.

Note: The power specification of this machine is used in mainland China. If it is used outside China, please confirm with our sales staff in advance.

2-3 Outline of the machine

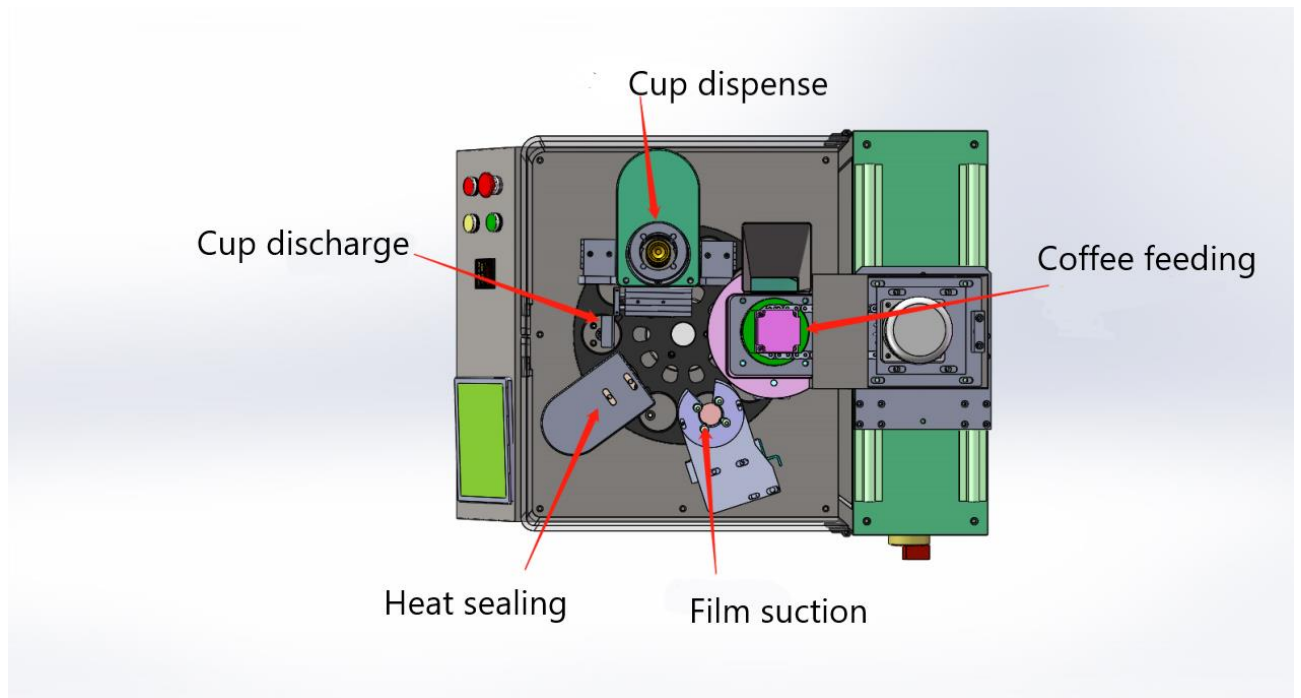

2-4 Dimensions of this machine

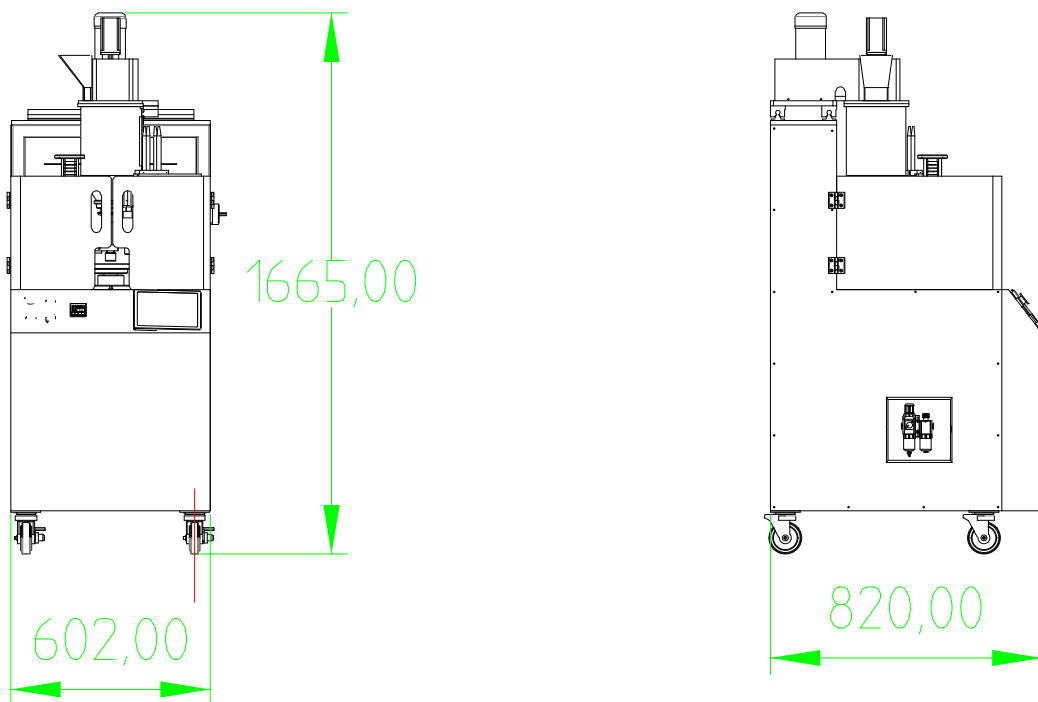

Chapter 3 Inspection and Installation

3-1 Inspection

This mini capsule packaging machine is shipped in wooden boxes. After arrival, please check the quantity of the goods according to the delivery and transportation list to confirm whether the machine and all parts are included. Inspect the packing crates for signs of damage or rough handling to confirm that the goods are intact.

If the goods are damaged or missing, please contact our company immediately and fill in the damaged and missing goods on the shipping note before signing for it.

3-2 Installation

1) Installation place

① Please leave enough space around the installation site of this mini capsule packaging machine for future maintenance

② Dimensions (length, width, height) are recorded in the outline drawing, please ask our sales staff for it.

③ The ground of the machine installation site should be flat and firm, which can ensure that the machine is in a horizontal state, and it is indoors with no vibration, no strong magnetic field interference, and certain light conditions. Also, the location should ensure that no foreign objects can fall from the building (ceiling) above the machine.

④ Please determine the distance between the required space and the compressed air source, power supply, and vacuum pump on the basis of convenient daily maintenance.

2) installation steps

① Unpack the wooden box and move the machine to the installation site.



Always pay attention to safety when moving the machine. When using a forklift, no one should ever get under the machine. Be sure to place the forks of the forklift firmly under the machine frame to prevent the machine from tipping over with excessive force.



In order to prevent the machine from tilting or the forklift being overloaded, please choose the lifting point carefully.

The fork of the forklift is in direct contact with the frame, ensuring that the gravity of the machine will not deform the stainless steel cover outside the frame.

Do not pinch wires, air distribution pipes, vacuum hoses, etc.

When moving the machine, cover the machine with canvas or plastic film to prevent the machine from being soiled.

② Install the mini capsule packing machine.

There are casters under the machine, and the front casters have a brake mechanism. The wheels can be fixed by stepping on them. Please fix the wheels.

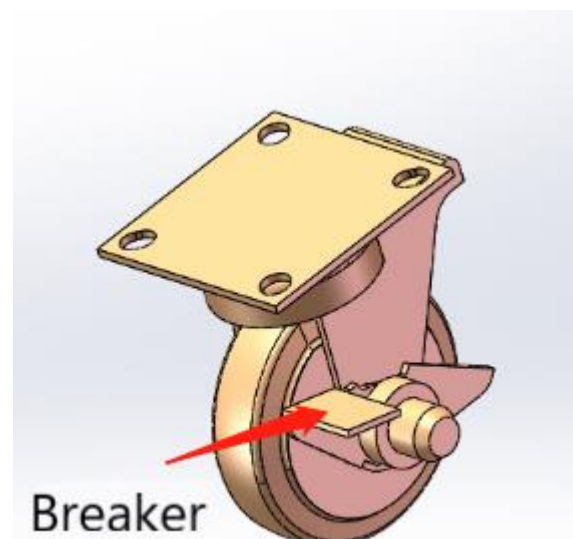

③ Connect compressed air.

Connect compressed air to the air inlet of the small capsule packaging machine with a 10mm diameter trachea. When the compressed air is working normally, the pressure is not less than 0.5MPa, and the compressed air must be clean and dry.

④ Connect all mechanical equipment grounding wires.

Before using the equipment, be sure to install the ground wire.



Failure to ground it may result in an electric shock.

Installation and maintenance of electrical wiring shall be carried out by persons qualified for electrical operation.

⑤ Power up the machine.

Turn off all circuit breakers in the electrical box, connect the main power supply of the machine's incoming line, and supply power to the machine.



For the total power supply of the small capsule packaging machine, a power switch must be installed nearby, and a circuit breaker suitable for the total power of the packaging machine must be installed.

⑥ Run the small capsule packing machine.

Turn on the main power switch of the packaging machine, keep the main power circuit breaker, control the power circuit breaker to be on, and test whether the main machine button is normal.



Before running, make sure that there are no tools, cloths and other items on the

machine.

Before running, make sure that other people around the machine are in a safe area.

Before operation, confirm whether the air circuit is connected.

After the installation is complete, please confirm the following:

Are all bolts and nuts loose?

Is the connection of the electrical wiring firm and reliable?

Does it work normally in safety switches such as emergency stop?

After installation is complete, please clean the machine before starting to use it.

Chapter 4 Operation

4-1 Precautions during operation

Precautions before operation



1. Never start and operate the machine until you understand all safety precautions, installation precautions, operating procedures, and cleaning and maintenance procedures.
2. Be sure to confirm that all safety switches operate normally.
3. Be sure to confirm that the safety cover and safety device are working properly.
4. Before operating each equipment, make sure that no one is near the equipment.

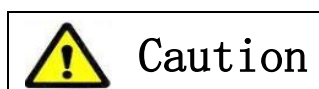

1. Make sure that the air hose and the vacuum connection tube are connected to the unit properly.
2. When starting the machine or restarting operation after an emergency stop, be sure to check whether there are any objects on or around the machine that may be caught in the machine or affect the operation of the machine.

Precautions during operation



During the operation of the machine, the operator should not put fingers, hands, head and clothes near the machine. After stopping the machine and turning off the power, remove the product that failed to supply, and correct the position or foreign matter mixed in. Otherwise, it may get caught in the machine and cause injury.



After the machine starts to operate, please check the status of the products packaged in the machine in a timely manner. (sealing state), manage and record for preservation as needed.

Precautions after operation



Do not clean during operation. After the machine is stopped, move it to a position where it is easy to clean by jogging. Then clean with the machine stopped. Failure to do so may result in injury.



1. When cleaning the machine, do not use hot water above 50°C or chemicals that are not suitable for this machine. Failure to do so may cause parts to deteriorate, deform or discolor.
2. After cleaning the feeding device, install and fix the parts as they are.
3. Please thoroughly clean and sterilize the parts in the feeding and dosing device that are in direct contact with the material. Otherwise, substandard products may be produced.
4. Do not spray water on the inside of the rack, the inside of the electrical box, the turntable, the air outlet on the top of the electrical box, the feeder servo motor, etc.

4-2 Operation switch and touch screen description

1) Main external switch of the machine

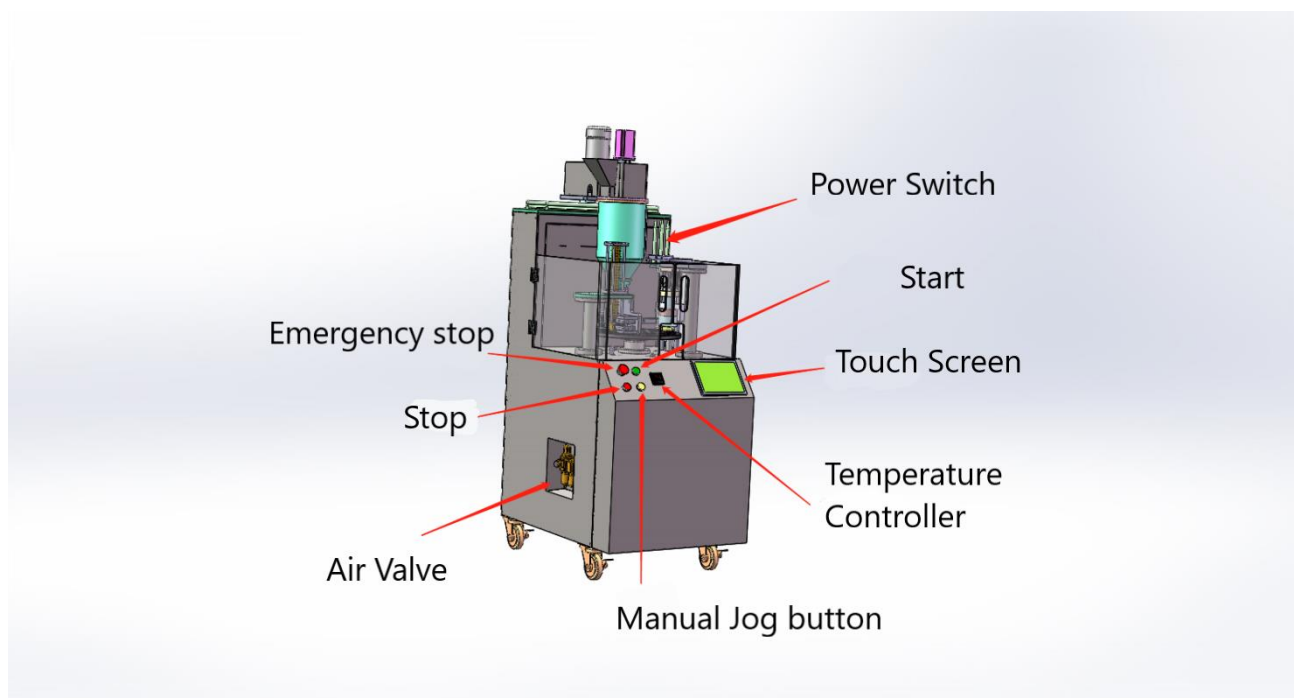

1. Touch Screen

The operation parameter setting of the packaging machine, function selection, manual test, alarm display, host operation and stop, etc. can be completed through the touch screen operation.

2. Emergency stop button

In case of emergency, press the button, the machine stops in an emergency and locks in the pressed state. To operate again after troubleshooting, turn the button in the direction of the arrow (clockwise) to release the lock.

3. Electrical panel

The electrical panel of the mini capsule packaging machine is equipped with main electrical components such as circuit breakers, PLC program controllers, control signal amplification modules, frequency converters, and servo motor drivers.

4. Main power switch

Control the power on or off of the mini capsule packaging machine. When cleaning, maintaining and maintaining the packaging machine, the switch must be turned off.

2) Touch screen operation instructions

Turn on the power of the packaging machine, close the main power switch, the screen displays the [initial screen] page, select the corresponding language.

Initial interface: home page of the machine, you can choose language at this screen and switch to other screens.

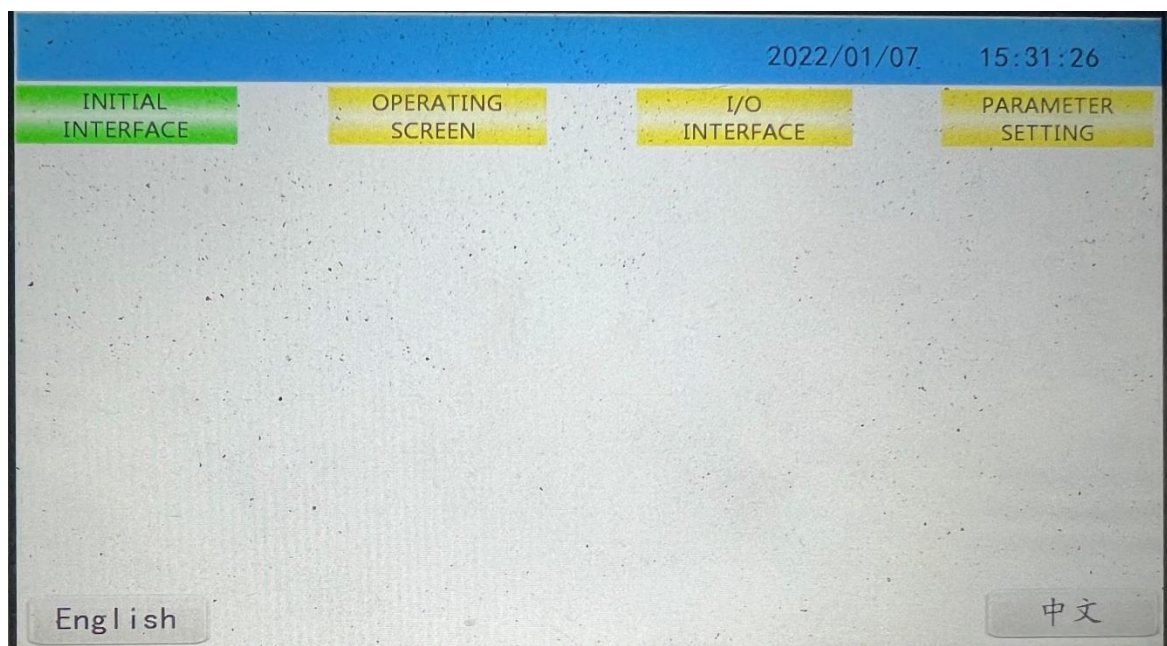

【Options】

[Operation Screen]: enter the operation interface page, which is used to control the operation of the machine.

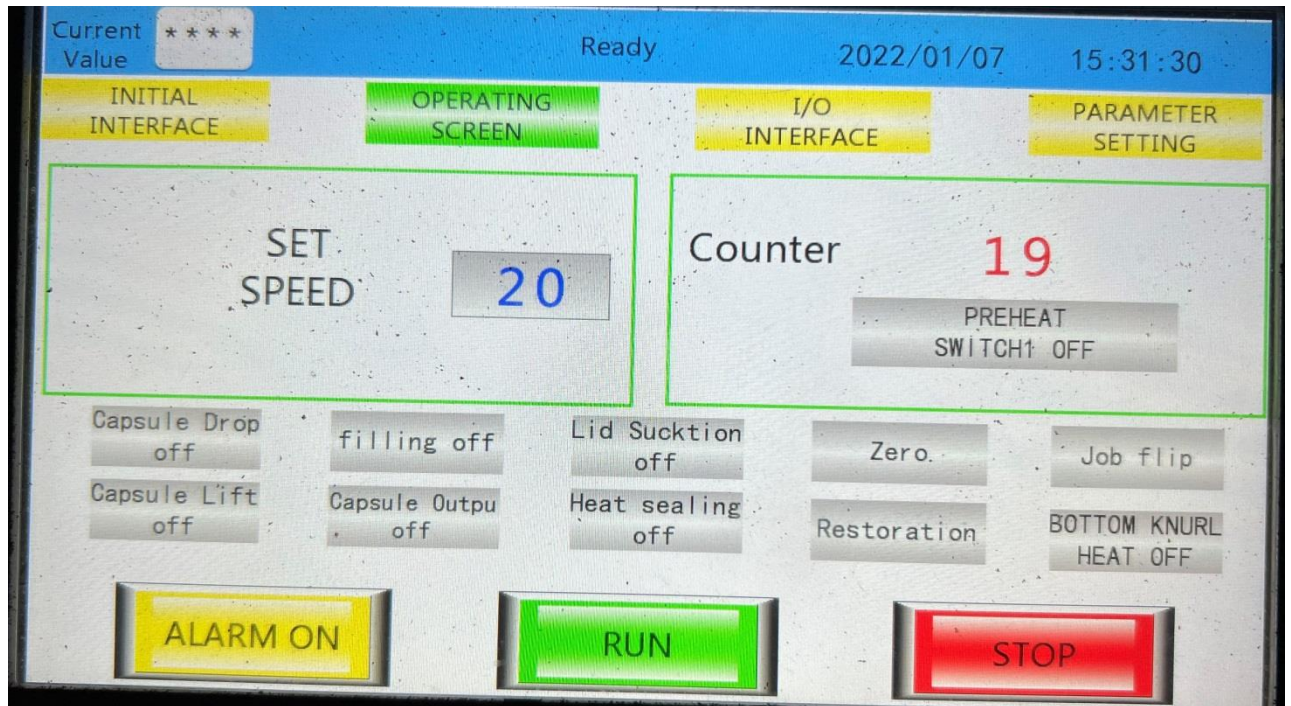

Explanation of each function on this screen:

Current value: the current position of the encoder

Operation screen: in green, means you are at Operation screen

Set Speed: set up machine speed, please test the best speed for your blend. Recommended speed: 15-25 capsules per minute, depends on your blends.

Counter: counting how many cups already produced by this machine.

Preheat switch off: wrong description, it should be reset the counter here.

Capsule drop off/on: turn on (in green) to drop the cups, off means no cup will drop

Filling off/on: turn on filling coffee or not

Lid suction off/on: turn on/off to pick the lid on the cups or no action

- Zero: empty the hopper when finish the production.
- Jog flip: turn on this switch, then press the JOG button, the turntable will turn on another direction, it is used to clean or remove malfunction cups, or debugging the machine.
- Capsule lift off/on: turn on/off to enable/disable the cylinder to push up the cups when it is discharged.
- Capsule output off/on: turn on/off to push the cup out or not
- Heat sealing off/on: turn on/off to enable/disable heat sealing function. Note: the heating will be on automatically when the machine has power.
- Restoration: Push this button to let the turntable moves back to the original position. You can use this button after emergency stop or debug the machine.
- Bottom Kunrl: Wrong description, this is an empty button for backup
- ALARM ON: Wrong description, should be JOG. Debug the machine manually. You can watch every second movement of every procedure by push this button.
- RUN: Start to run the machine
- STOP: Stop the machine, when you push this button to stop the machine, all working stations stop, but the turntable will still move forward to the initial position.

[IO interface]: It is also named debug interface, which used for debug the machine when any problems happen, or monitor the machine working well or not.

Password for IO interface is: 888888

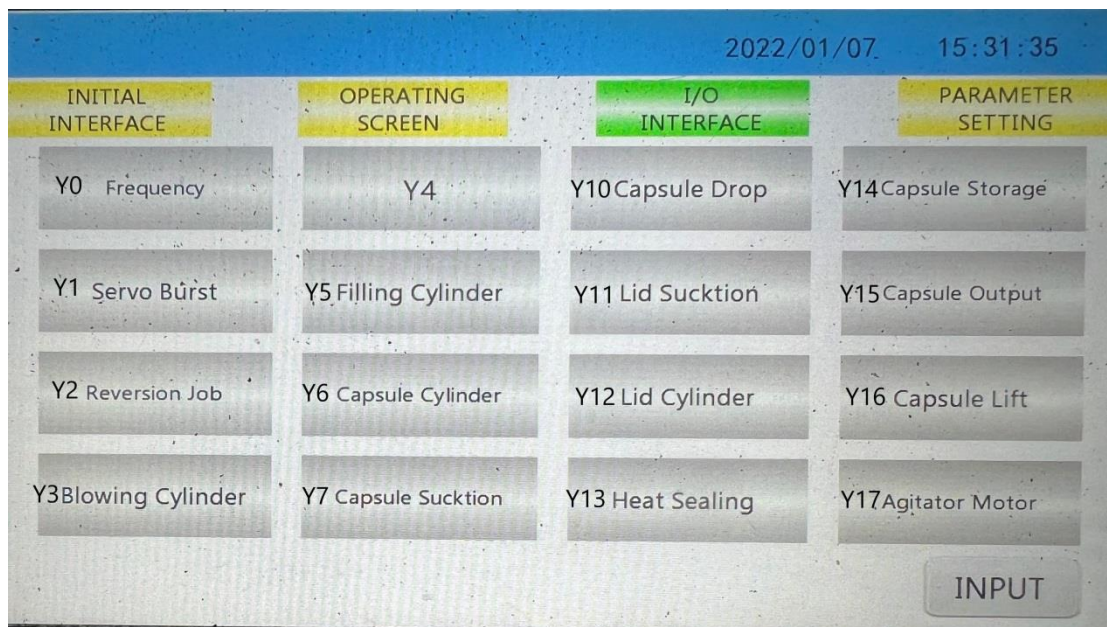
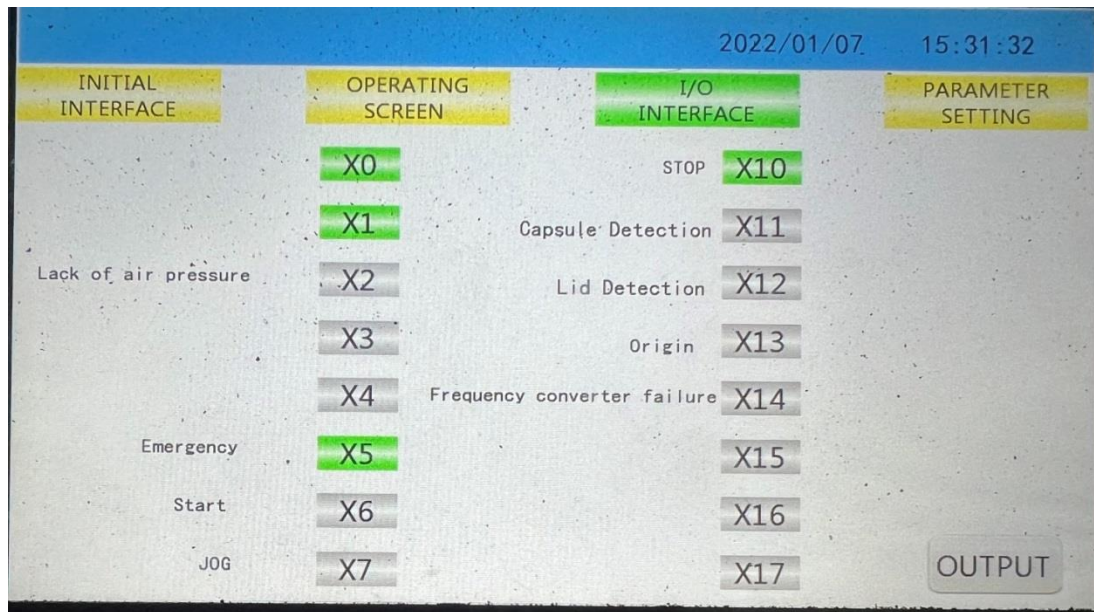

In the first screen of IO interface, all X buttons are used to monitor the status of the machine, and are not operational. For example, when the air pressure is not enough, the X2 will turn green.

In the second page of IO interface, Y0, Y1 and Y2 are monitoring the status only too.

Y0: show the status of frequency converter, green is on and gray is off

Y1: Show the servo is working or not

Y2: The button will be in green, when the turntable jogs on reverse direction.

From Y3 to Y17, except Y4 for backup, all other buttons are operational, which most used for debugging the machines. By pushing those buttons could test every movement of every work station. Detail operations for each work station are referred to <Quick Start Manual>, or 4-4 of chapter 4.

- Y3: This button is used for picking up the lid process. It should work with Y11 and Y12. Pushing this button (turn green) will blow a little air to the lid sucker to separate the lid from the sucker and then release the lid on the cup.
- Y4: Backup button
- Y5: This cylinder will push the cups up when filling the coffee into the cups.
- Y6: This cylinder is used for cup dropping process, and works with Y7, Y10 and Y14 cylinder together. Pushing this button will push the cup sucker up.
- Y7: After Y6 cylinder push the sucker up, the vacuum will work on Y7 and suck the cups down into the mold of the turntable.
- Y10: When this cylinder works, it will open the holder of the cup silo and let the cup drop down.
- Y11: Pushing this button to suck the lid down
- Y12: This cylinder will move the lid sucker up to let Y11 sucking the lid, and then turn 180 degree to move the lid sucker down.
- Y13: Pressing this button to move the heating head down and seal the lid.
- Y14: The cylinder holds the cups in the cup silo and when it opens, it will release one cup to Y10 and ready to drop.
- Y15: It will work with Y16 to discharge the cups.
- Y16: The cylinder pushes the cups up and then Y15 push the cups out.
- Y17: Turn on/off the stirring motor to stir the coffee inside the hopper.

[Parameter Setting]: there are parameters for each movement of the machine in this screen.

Warning: The parameters on this page are the most important for this machine, please DO NOT CHANGE anything unless you completely understand the principles for how the machine runs. Please record this page before changing any parameters.

Current Value		****	STOP	50	100	OUTPUT	2022/01/07	15:31:38
INITIAL INTERFACE		OPERATING SCREEN			I/O INTERFACE		PARAMETER SETTING	
Capsule Sucktion	24	630	Filling	110	480			
Capsule Drop	150	450	Capsule Output	250	500			
Capsule Storage	900	640	Capsule Lift	80	600			
Capsule Cylinder	50	400	Heat Sealing	60	420			
Filling Cylinder	50	500	Lid Sucktion	50	260			
Lid Cylinder	70	580	Agitator	600	100			
Filling	262	270						
Lid Detection Delay	4	Sealing Delay	1	Filling Delay	1	Lidding Delay	3	

Parameter setting page-1

Every parameter in this page controls one cylinder, motor, vacuum or sensor to take one action in the machine.

Current Value: This encoder number indicates the current machine position.

The most important device is the encoder inside the machine. It controls and shows the machine position. In the meantime, it works like a timer to control every movement and every procedure of the machine. The encoder number shows the current position of the machine. It is always between 0-999, and after 999, it starts from 0 again. For example, the current machine in the operation page is 509, which the encoder arrives the position 509. The number in the first column is the time to start that procedure, and the number in the second column is the time to stop that procedure.

Stop:	Indicate the stop position of the machine.
Capsule Suction:	The vacuum start working to suck the cup down when the encoder runs and arrives at position 24 and stops when the encoder arrive position 630.
Capsule drop:	The cylinder starts to open cup holder at position 150 to release the cup to the turntable and close the holder at position 450.
Capsule storage:	The cylinder starts to open cup holder at position 900 to release one cup to the cup holder controlled by the capsule drop cylinder and close the holder at position 640.
Capsule cylinder:	The cylinder pushes the cup up when dropping cups at position 50, and return at position 400.
Filling Cylinder:	The cylinder pushes the cup up when filling coffee at position 50, and return at the position 500.
Lid Cylinder:	The cylinder goes up at position 70 and goes down at 580.
Filling/blowing:	The vacuum gives a little air to release the lid from the sucker from position 262 to 270.
Filling:	The auger fills coffee into the cup from position 110 to 480.
Capsule output:	The cylinder pushes the cups out from position 250 to 500.
Capsule lift:	The cylinder pushes the cup up from position 80 to 600.
Heat Sealing:	The heater seals the lids on the cup from position 60 to 420.
Lid suction:	The vacuum sucks the lid from position 50 to 260.
Agitator:	The stirring motor runs from position 600 to 100.

Interval of work station between procedures:

The following 4 values are used to calculate the timing of each working station inside the PLC program. They are used for machine controlling. The customer SHOULD NOT CHANGE those values unless the customer has to re-arrange the working stations.

Definition of Interval of work station:

If we name the hole (work station) on the rotary plate is the first hole (work station) which is the sensor to detect if there is a cup inside the hole. Then the second hole (work station) is where the hopper fills the coffee into the cup. **Therefore, we define the interval between these two holes are 1, which is shown as “Filling delay” = 1.** If moving the sensor to the hole before the first hole, the number here should be 2.

Lid detection delay: Coffee filling station to lid detection station: There are 4 work stations between Coffee filling (including the Coffee filling itself) and the lid detection. So, the interval here is 4.

Sealing delay: Lid detection to sealing station is 1.

Filling delay: Cup detection to coffee filling station is 1.

Lidding delay: The coffee filling to the station to put the lid is 3.

Parameter setting page-2

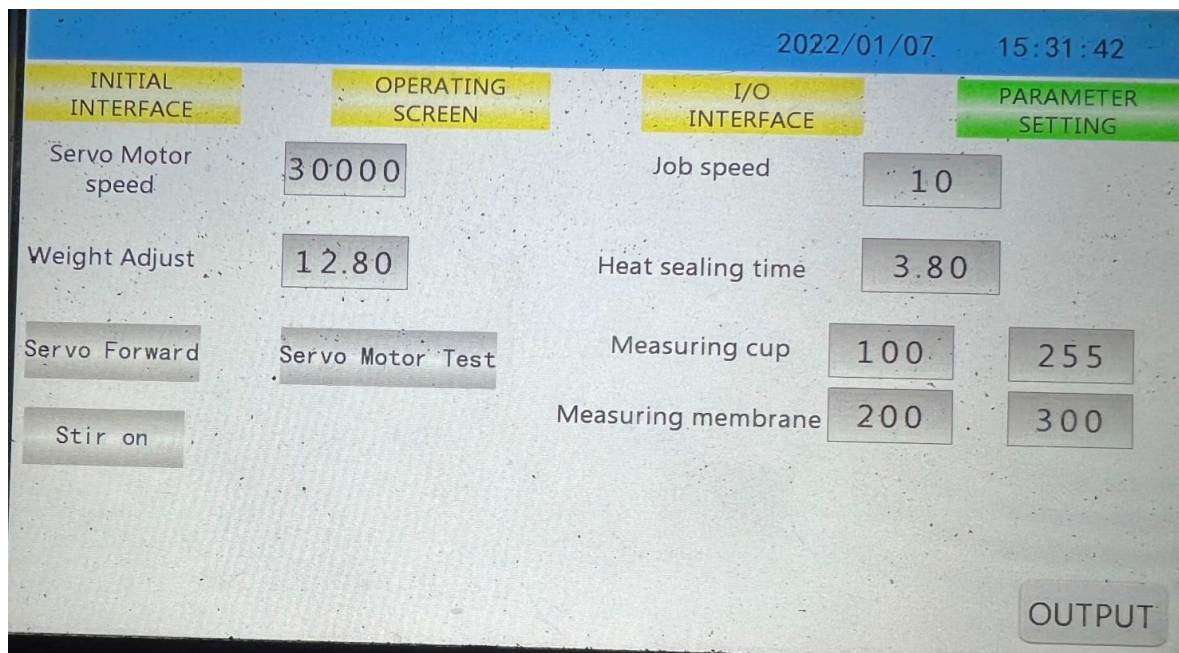

Servo motor speed: The speed of servo motor, adjusting this speed can adjust the filling weight, but we do not recommend doing so.

Weight Adjust: Adjusting the filling weight. The number here is how many numbers of circle the screw should turns. It is NOT weight. Please refer to Quick start manual to see how to adjust the weight.

Servo forward:	The servo motor will continue working when you press on this button and stop when releasing this button.
Servo motor test:	The servo motor will continue working when you CLICK this button (turn on) until you click it again (turn off). They are both used for testing the servo motor and filling function.
Stir on:	Turn on/off the stir bars inside the hopper.
Jog speed:	The speed of jogging the machine. 10 means the machine will pack 10 cups per minute.
Heat sealing time:	The time for heat sealing the lid.
Measuring cup:	The cup detection sensor works from position 100 to 255.
Measuring membrane:	The lid detection sensor works from position 200 to 300.

4-3 Operation procedures

1. Start button:

Press the start button, the machine enters the automatic work mode.

2. Manual Jog button

Press the jog button, the machine does not drop the cup, and the cup that is already on the station still works, press one time to forward one station.

3. Stop button

Press the stop button and the machine goes back to the initial point and then in stop mode.

4. Emergency stop button

Press the emergency stop button, the machine will stop immediately. It is basically used for machine failures or safety conditions. After pressing the emergency stop button, check the fault. Turn off the machine or press the reset button on the touch screen and the reset will return to normal.

4-4 Auto or manual/debugging operation procedures

1) Cup dropping device

Automatic mode, in operation screen, if click the <Capsule drop off> button, it will stop taking the cup, the button becomes the <Capsule drop on>, and then if click again, it will drop the cups again.

Manual/Debug mode, in IO interface, follows these procedures to drop one cup:

- Click the Y6 <capsule cylinder> button to push the sucker up.
- Click the Y7 <Capsule suction> button start vacuum sucking the cup.
- Click the Y14 <Capsule storage> button to **close the cup silo holder**.
- Click the Y10 <Capsule drop> button to **open the cup drop holder**.
- Click the Y6 <capsule cylinder> button again to **bring the cup down and place into the turntable** which the vacuum suction is still on.
- Click the Y7 <Capsule suction> button again to cut off the vacuum suction.
- Click the Y10 <Capsule drop> button again to **close the cup drop holder**.
- Click the Y14 <Capsule storage> button again to **open the cup silo holder**.
Completing the whole process to place one cup into the turntable.

In auto mode, one <Capsule drop on/ off> button control the above 8 steps, but in manual /debug mode, we need to do these 8 steps one by one, so that if there are any problems, we can find it easily.

2) Capsule detection device

Normal situation:_The cup passes through the turntable and goes to the detection station. When there is a cup, the photoelectric components will light up, then go to the next station, and feed automatically. If no cup is detected, go to the next station without feeding.

Debugging method: if there is a problem to detect the cups, following the procedure here to debug the problem:

Put the cup into the cup detection station, check if <X11> Capsule detection is on (turn green) in the touch screen debugging screen (IO Interface), and if there is no cup on the station, <X11> should be off, which means the detection device is

working normally. If it works abnormally, adjusting the height, distance, position, angle, or sensitivity of the optoelectronic components until <X11> works normally.

3) Coffee feeding device

In automatic mode, when the previous station detects that there is a cup, the feeding device (auger and hopper) automatically fill the coffee into the cups. If there is no cup detected in the previous station, it will not feed the coffee.

In manual mode, click the Y5 <filling cylinder> button to let the cylinder push up the cup, and then click <Servo Forward> button in Parameter interface page 2 to manually fill one cup of coffee.

How to adjust filling weight to the desired number should refer to Quick Start Manual, Adjusting the Weight.

4) Nitrogen filling device (Option)

There is a gas valve joint on the station. The external nitrogen equipment can be directly connected to the gas valve joint. The cylinder connect diameter is 6mm.

Debugging method: Adjust the gas valve joint, and the nitrogen gas output meets the product requirements.

5) Film suction device

In automatic mode, if the previous station (the feeding device) works, and the film is automatically sucked, otherwise there will be no action at this step.

In manual mode, the suction cup should face upwards when it stops, then click the Y3<Blowing cylinder>, Y11 <Lid suction> and Y12 <Lid cylinder> button in IO interface to suck the film once.

6) Film/Lid detection device

If there is a film/lid on the cup, the photoelectric switch is on; if there is no film/lid, the photoelectric switch will be off. If there is no film detected, the machine will not heat seal the film/lid on the cup in the next station.

Debugging method: When there is a film/lid, the X12 Lid detection in the touch screen IO interface will light up (turn green), otherwise it will not light up. If the film detection device is detected abnormally, adjusting the height, distance, position, angle, or sensitivity of the optoelectronic components until <X12> works normally.

7) Heat sealing device

In automatic mode, the previous station detects if there is a film/Lid or not. If there is a lid/film on the cup, then seal it automatically, otherwise, the heating head will not move down and skip that cup without sealing.

In manual mode, click the Y13 <Heat Sealing> button, the heat sealing cylinder will be pushed down, pressed copper head on the surface of the cup, and seal it. Push Y13 again to return the cylinder when the sealing is done.

8) Discharge the cups device

In automatic mode, regardless of whether there is a cup in the station, the ejector cylinder and the cup-push-up cylinder will act.

In IO interface manual mode, first click the Y16 <Capsule Lift> button to push up the cups, and then click Y15 <Capsule Output>button to discharge the cups.

Chapter 5: Spare Parts, Circuit Diagram and Cylinder arrangement

5-1 Spare parts with the machine

No	Description and name	Unit	QTY
1	Sucker to suck the cup down	Piece	2
2	Sucker to suck the film down	Piece	2
3	Heating Pipe	Piece	4
4	Thermocouple	Piece	2
5	Inner hexagon wrench	Set	1
6	Adjustable wrench 8 inches	Piece	1
7	Hexagon wrench	Set	1
8	Electrical box key	Piece	1
9	Air gun	Piece	1

5-2 Circuit diagram

- Y4 feeding 2
- Y77 feeding coffee 1
- 5 feeding cylinder
- 6 suck cup up cylinder
- 7 suck cup
- 10 release cup
- 11 suck film
- 12 suck film up
- 13 and down
- 13 Heat sealing
- 14 cup storage
- 15 cup discharge
- 16 cup push up
- X1 feeding 2 signal
- X2 feeding 1 signal
- X5 emergency stop
- X6 start
- X7 Manual/ Jog
- X10 stop
- X11 cup detection signal
- X12 film detection signal
- X13 Encoder initial point
- Y1 Servo motor pulse
- Y3 Servo motor direction
- X3 Servo alarm

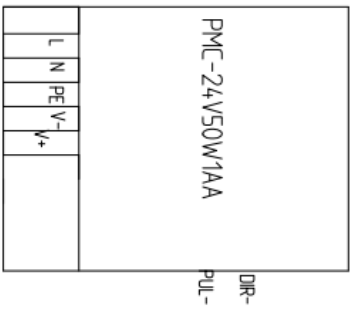
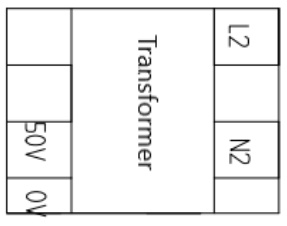
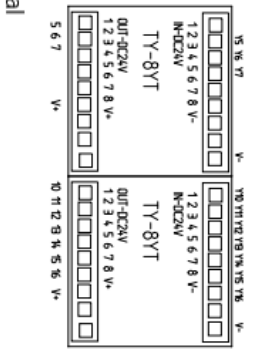
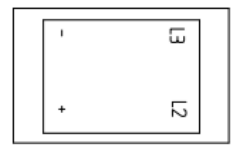
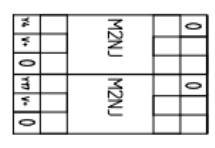
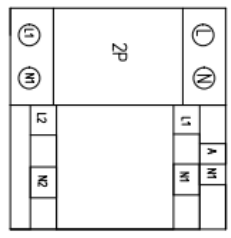

X3	Y3	Y1	V-	M2	M1	X7	X1	X2	X5	X6	X10	X11	X12	X13	Y1	Y3

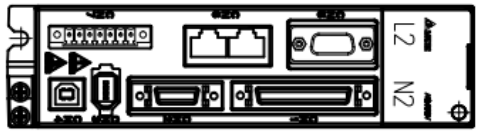

400W



5-3: Cylinder arrangement diagram

	1	2	3	4	5	6	7	8	9	10
中文	储杯	放杯	吸杯上 气缸	吸杯	加料气 缸	吸膜上 下	吸膜	热封	顶出	出杯
English	Capsule Storage	Capsule Drop	Capsule Cylinder	Capsule Suction	Filling Cylinder	Lid Cylinder	Lid Suction	Heat Sealing	Capsule Lift	Capsule Output

