

MODEL **GP-140** COFFEE GRINDER

HIGH CAPACITY DISC-STYLE COFFEE GRINDER FOR ALL GRIND TYPES



Model GP-140 Coffee Grinder

The Model GP-140 is an industrial disc-style grinder designed to run continuously and deliver a superior coffee grind. The GP-140 uses 7.1 inch diameter “diamond hard” grinding discs that are precision-cut to optimize cutting action with infinite adjustment control, resulting in a cool, uniform coffee grind for optimal brew performance.

- **High Capacity**
- **Infinite grind adjustment**
- **Easy to clean and operate**
- **“Diamond hard” grinding discs**

ACCOMMODATES ALL GRIND SIZES

ESPRESSO	FLAVORED COFFEE
DRIP	VENDING
REGULAR	COARSE



SERIES GP-140

PRECISION DISC-STYLE GRINDER

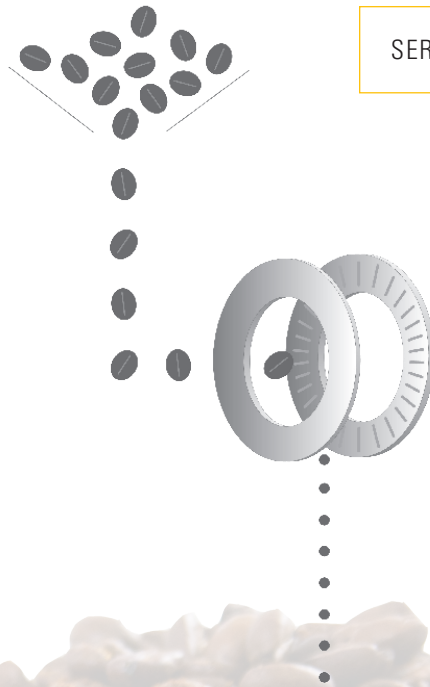

SPECIFICATIONS

Disc Size: 7.1 inches [180 mm] in diameter

Grinding Discs can be re-sharpened

Motor: 5 HP [3.7 kW] / 3 phase / 50 or 60 Hz available

Grind Range: Espresso - Coarse [200-3000 microns]

Capacity: 400-1000 lbs/hr [180-450 kg/hr], espresso to coarse respectively

Drawing: Available for download on website

FEATURES & OPTIONS

- Designed for fast and easy cleanout – By simply removing three dial plate knobs, the entire grinding chamber can be removed and cleaned in minutes.
- Simple maintenance and operation – With few moving parts, maintenance and operation are easy.
- Various grinding discs offered – Gourmet, flavored, and high capacity.
- Sharp teeth and ultra-hard metal alloys ensure both performance and disc longevity. Economical re-sharpening also available.
- Hopper Size: 4 cu-ft (75 lb)
- Bag holder tray (standard) or larger tote container (optional) for ground product collection.
- Hopper grate magnet (optional)



MODERN PROCESS EQUIPMENT CORPORATION • MPECOFFEE.COM

3125 SOUTH KOLIN AVENUE CHICAGO, ILLINOIS 60623, USA • SOLUTION@MPECHICAGO.COM • P: +1 773.254.3929 • F: +1 773.254.3935

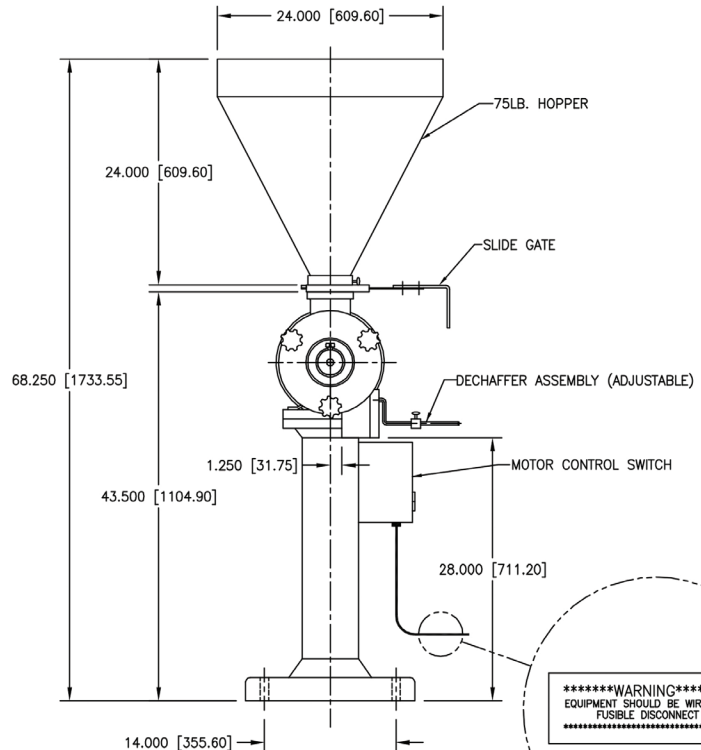
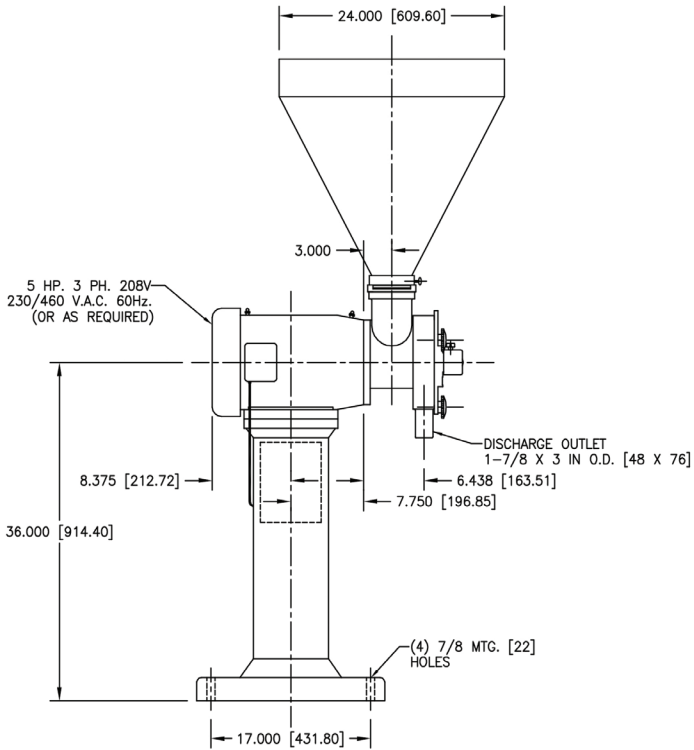

*****WARNING*****
EQUIPMENT SHOULD BE WIRED TO
FUSIBLE DISCONNECT

NOTES:

1. DIMENSIONS WILL BE INDICATED AS FOLLOWED, 1 [25.4]
ENGLISH (IN) METRIC (MM)

REFERENCE DRAWINGS:

GENERAL PURPOSE GRINDER ELEVATION

GP-807B

				MATERIAL	USED ON UNIT	MODERN PROCESS EQUIPMENT, Inc. <small>3125 South Kalle Avenue, Chicago, Illinois 60643</small>	DRAWN	RR	SCALE
				PATTERN NO.	GP-790D		DATE	9/29/08	8
REV.	CHANGE	DATE	BY				CHECKED		
							NAME OF PART	PART NO.	
							GP/GP-140 ELEVATION GENERAL PURPOSE GRINDER	GP-7536 C	