

DIEDRICH

— ROASTERS —



IR-12 Manual

TABLE OF CONTENTS

Table of Contents	1
1. IR-12 Manual Roaster Technical data	2
2. IR-12 Manual Roaster Drawings	2
Front View	3
Left Side View (Operator Side)	4
Rear View	5
Right Side View	6
Top View	7
Front Left - Isometric View	8
Front Right - Isometric View	9
Top View with Space and Utility Connection Information	10
Isometric View - Full Roasting System	11
Top view - Full Roasting System	12
3 Facility and Installation Preparations	13
4 Exhaust Ducting	14
5 Additional Documents and Information	16

1. IR-12 MANUAL ROASTER TECHNICAL DATA

General Information	
Green coffee capacity, Min-Max	0.55-26.5 lb.; 0.25–12 kg
Dimensions, maximum L x W x H	56 1/4 x 29 1/8 x 75 5/8 in; 1429x740 ¹ x1921mm
Shipping weight	1252 lb.; 568 kg
Shipping crate dimensions, LxWxH	61 x 41 x 77 in; 1549 x 1041 x 1956 mm
Full batch roast time to 440F (227C)	13 – 16 Minutes
Hourly output ¹ , 15 minute roast	106 lb ¹ /hr.; 48 kg ¹ /hr.
Exhaust airflow, Max	363 scfm; 617 scmh
Exhaust duct outside diameter	8 in; 203 mm
Temperature high limit	475F/246C burner off, 485F/252C pilot off
Electrical Information	
Volts AC (1-Phase)	100-120V or 200-240V
Frequencies	50Hz or 60Hz
Full Load Amps	11.1 Amps at 120V 60Hz 6.1 Amps at 230V 50Hz
Roaster Main Breaker size	15 Amps at 120V 60Hz 10 Amps at 230V 50Hz
Gas Information	
Gas Types (others if pre-approved)	Liquid Propane (LP) or Natural Gas (NG)
Maximum consumption	90,000 BTU/hr.; 26 kW
Typical consumption per roast ²	18,670 BTU.; 5.47 kWh
Inlet Pressure LP	12-14 in WC; 30-35 mbar
Inlet Pressure NG	8-9 in WC; 20-22.5 mbar
Inlet gas supply connection	1/2 in male NPT on roaster

2. IR-12 MANUAL ROASTER DRAWINGS

This section contains drawing views with dimensions and component descriptions. These drawing are valuable for familiarization with the Diedrich IR-12 Manual roaster and for space and utility connection planning. There are also drawings of the IR-12 Manual roaster with optional loader, destoner, cyclone, and Afterburner. This information is subject to change.

¹ Hourly “green” coffee output. Thus, the weight has not been corrected for moisture loss.

² Based on a 13-16 minute roast to 440F.

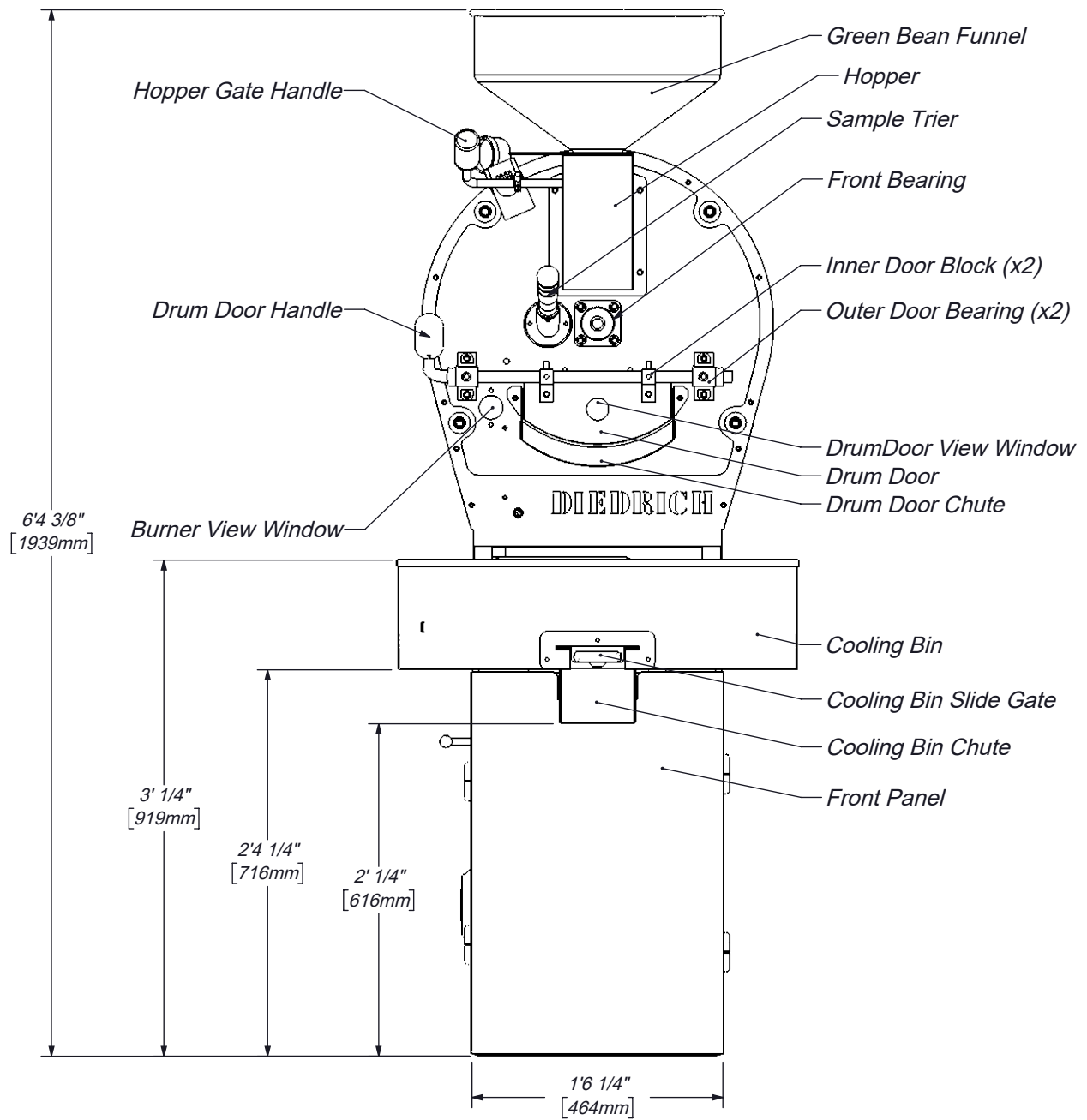

Front View

Scale 1:12

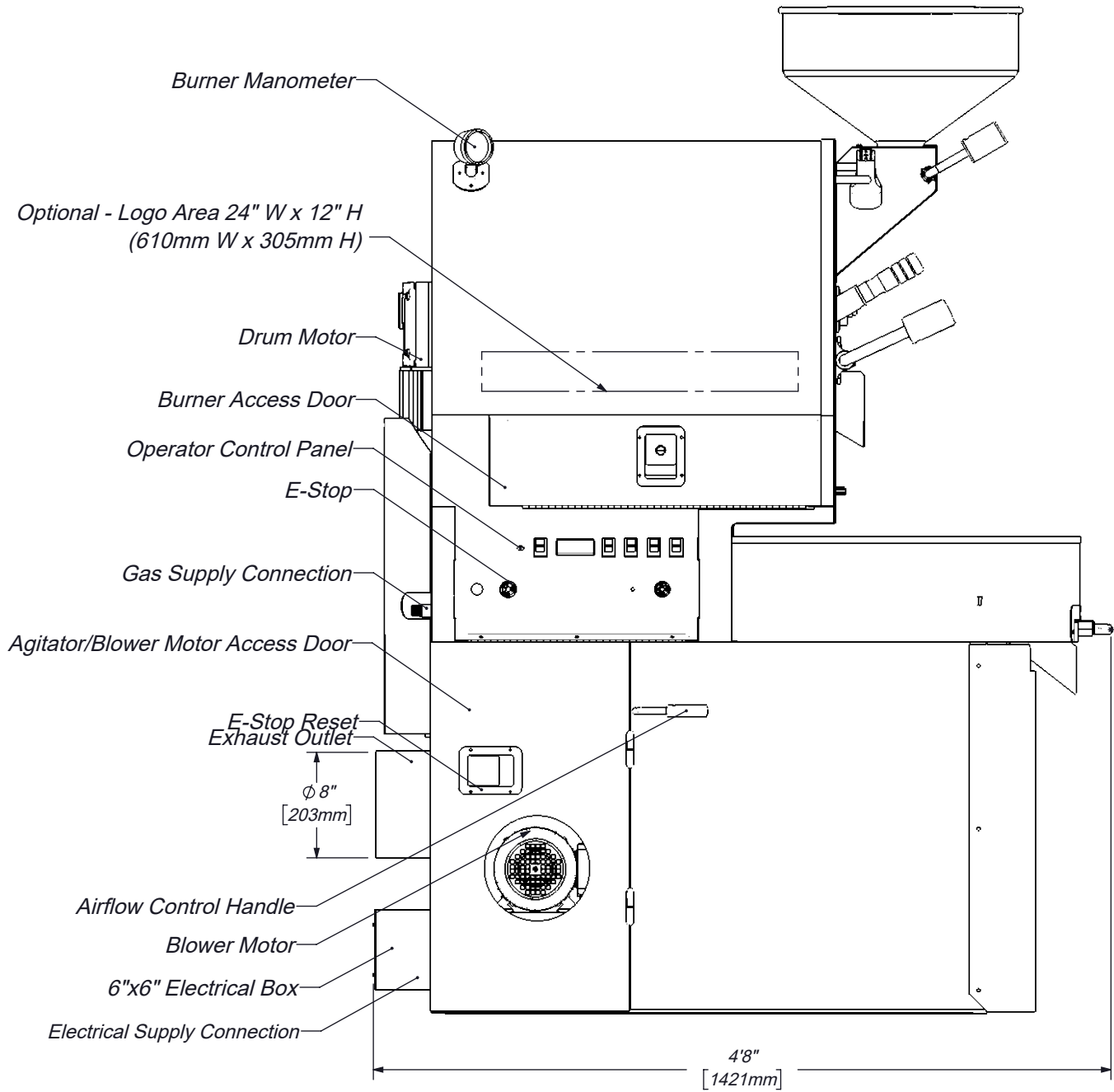

Left Side View

Scale 1:12

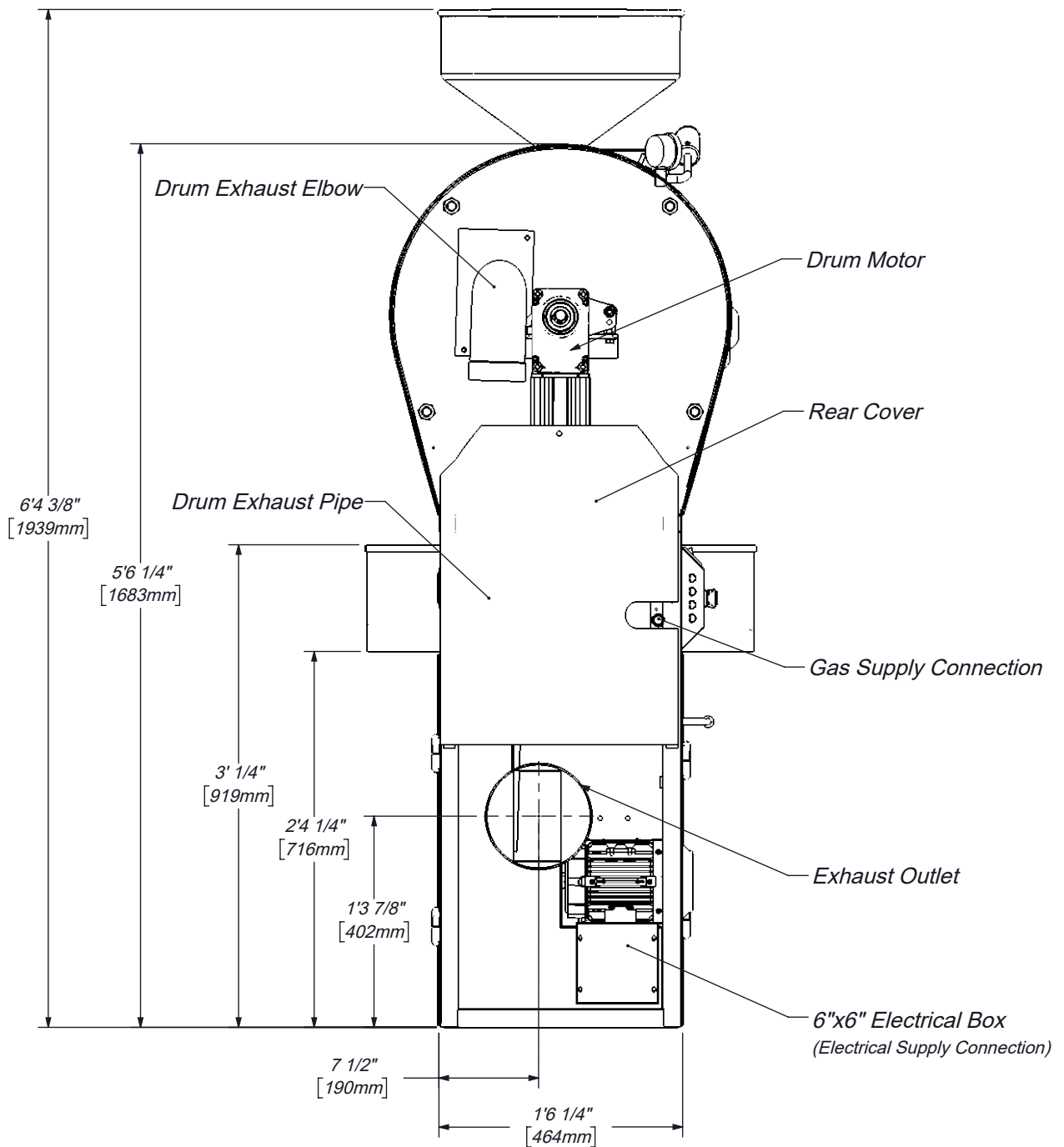

Rear View

Scale 1:12

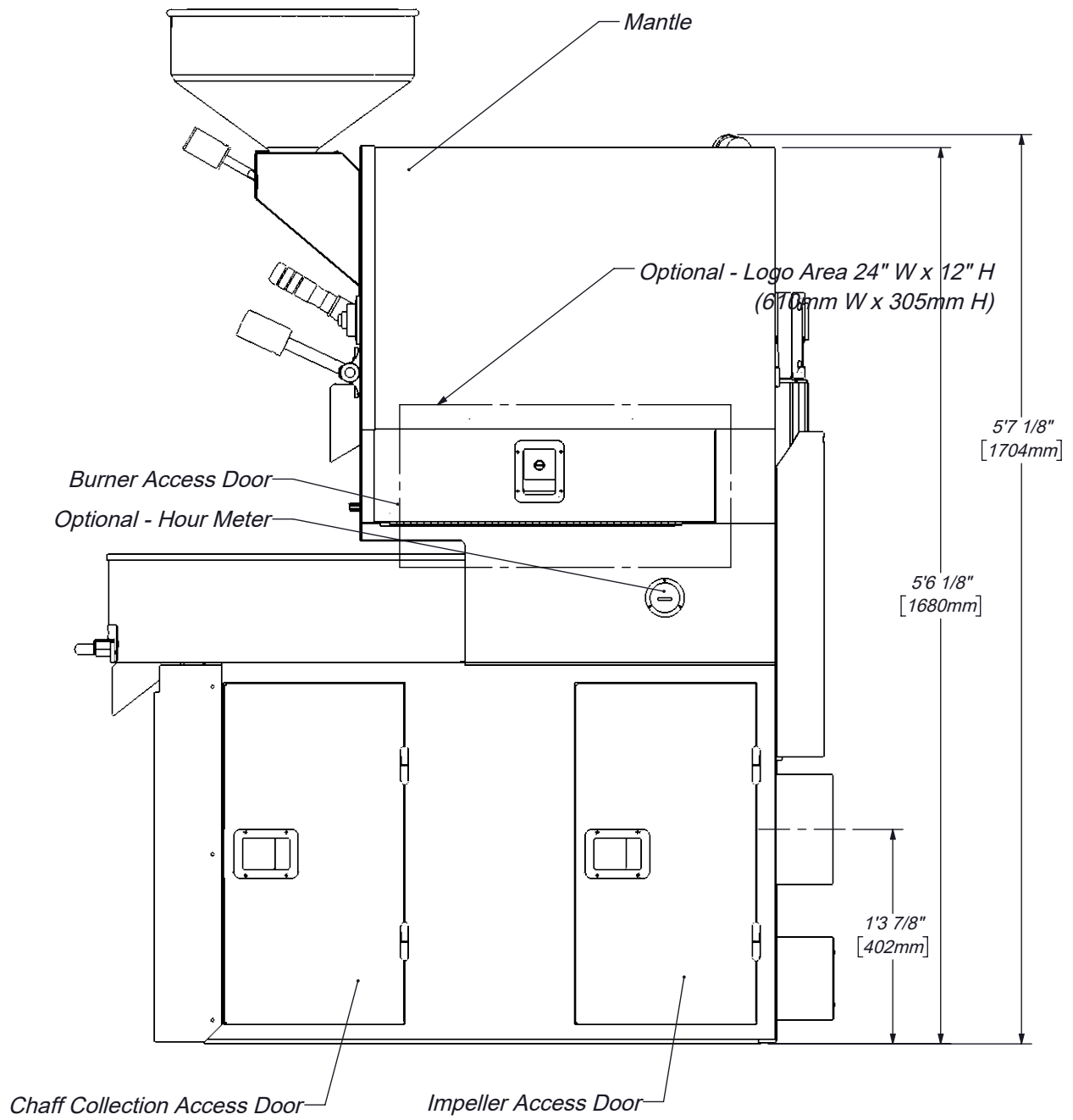

Right Side View

Scale 1:12

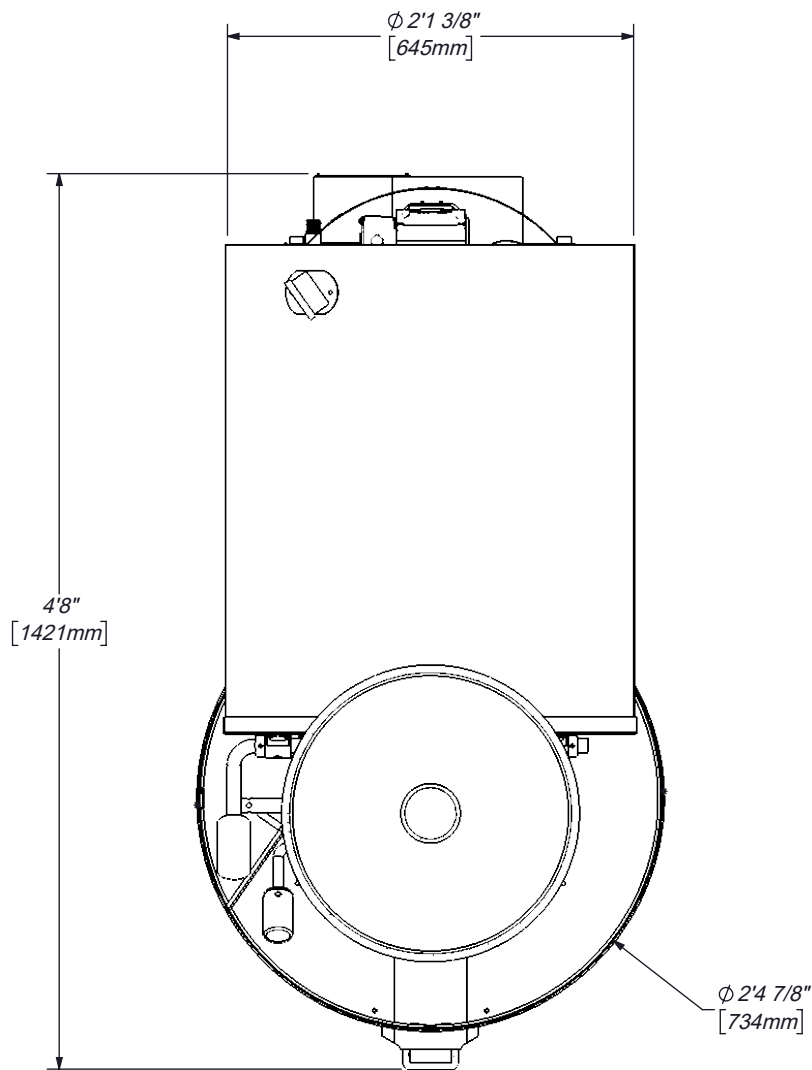

Top View

Scale 1:12

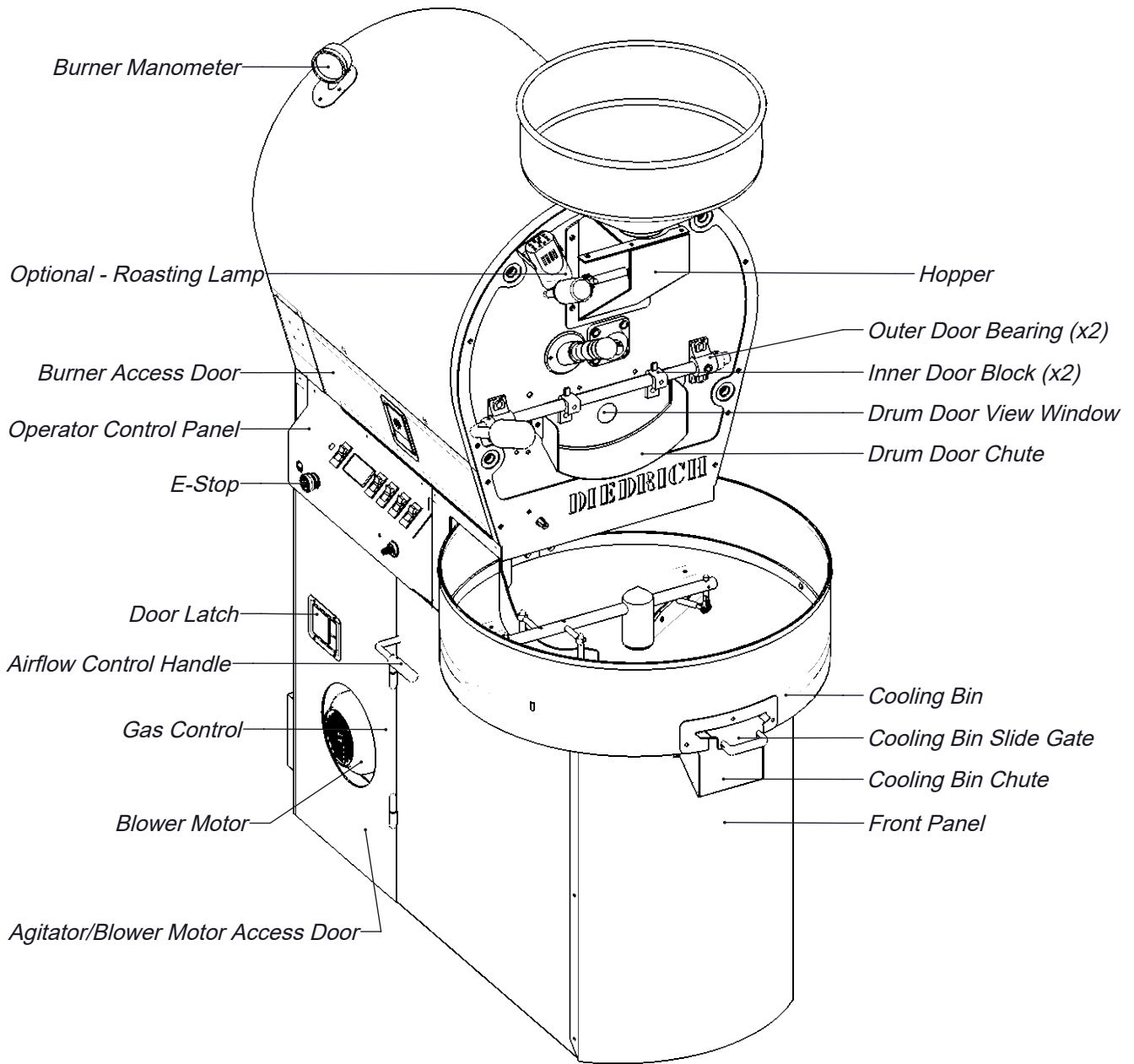

Front Left - Isometric View

Scale 1:12

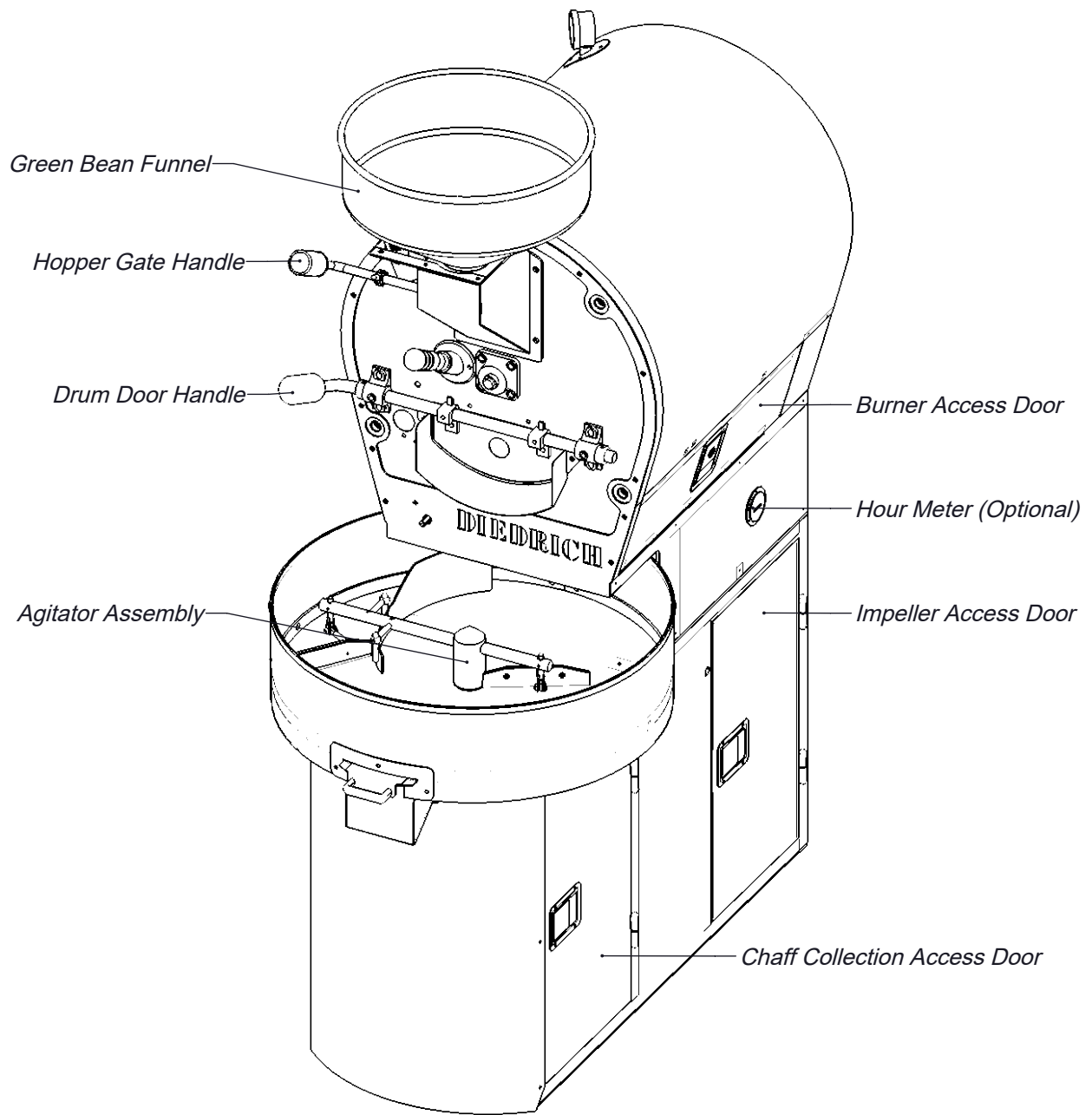

Front Right - Isometric View

Scale 1:12

Space and Utility Connection Information

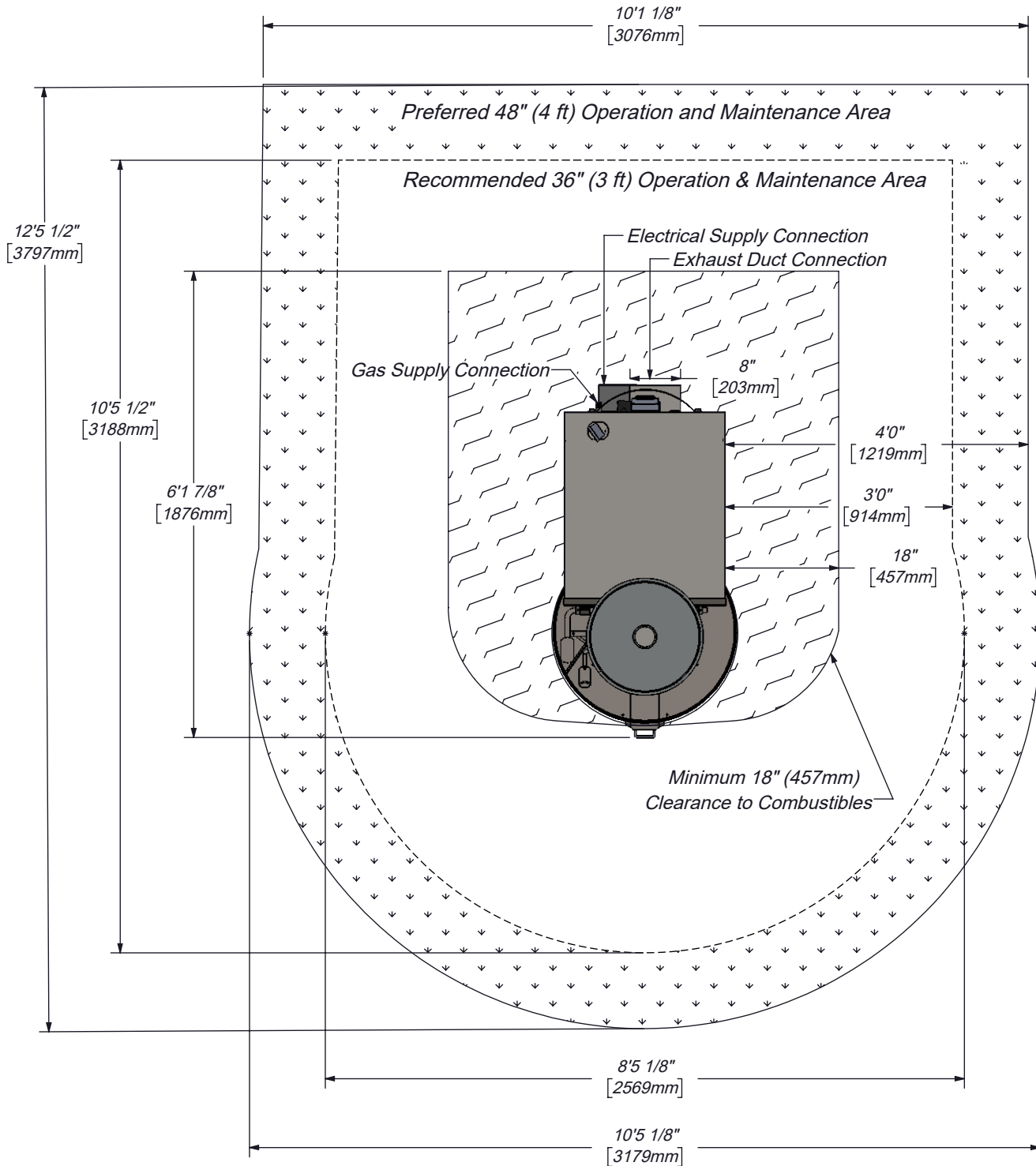

Top View

Scale 1:24

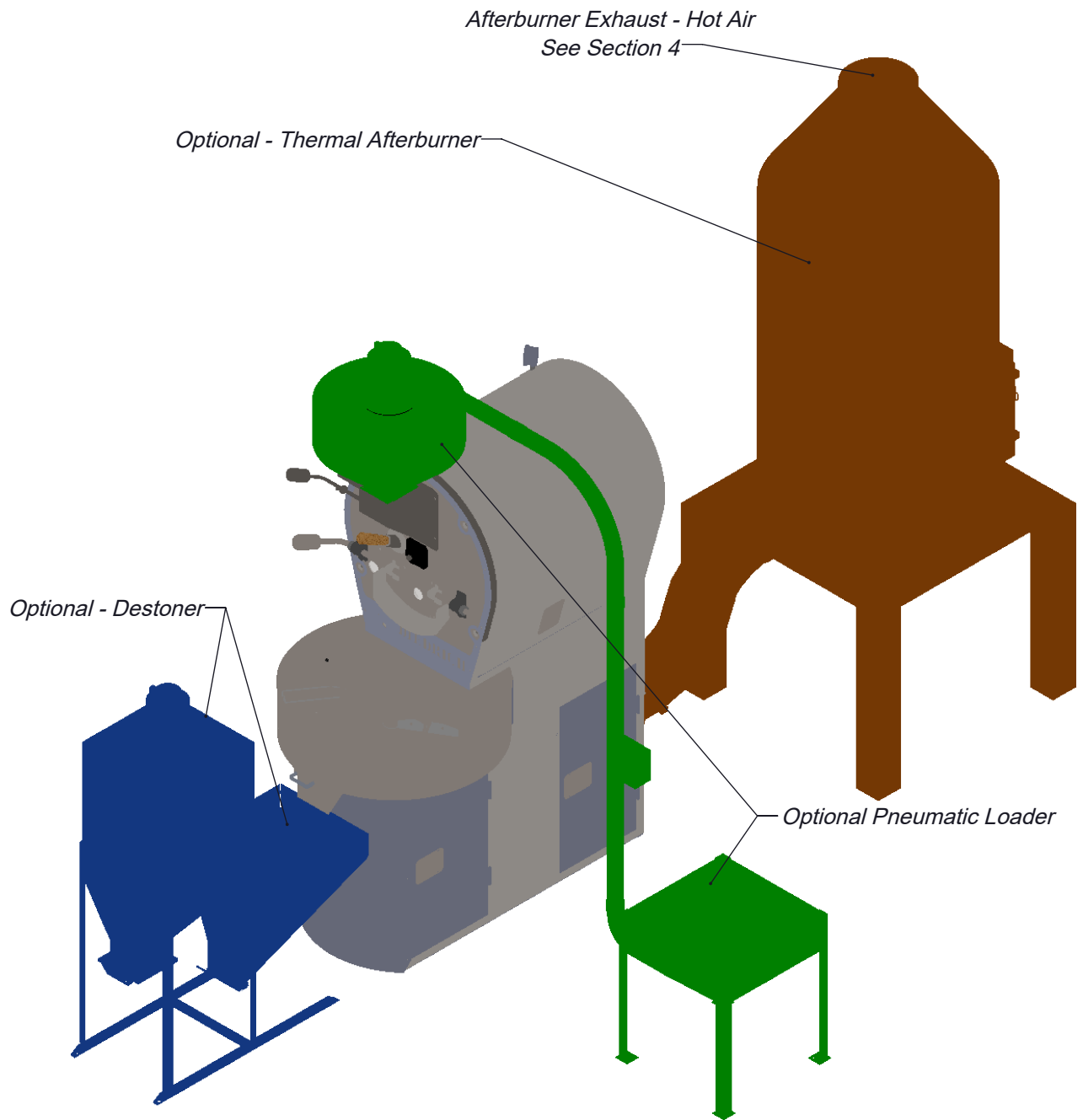

Isometric View - Full Roasting System

Scale 1:20

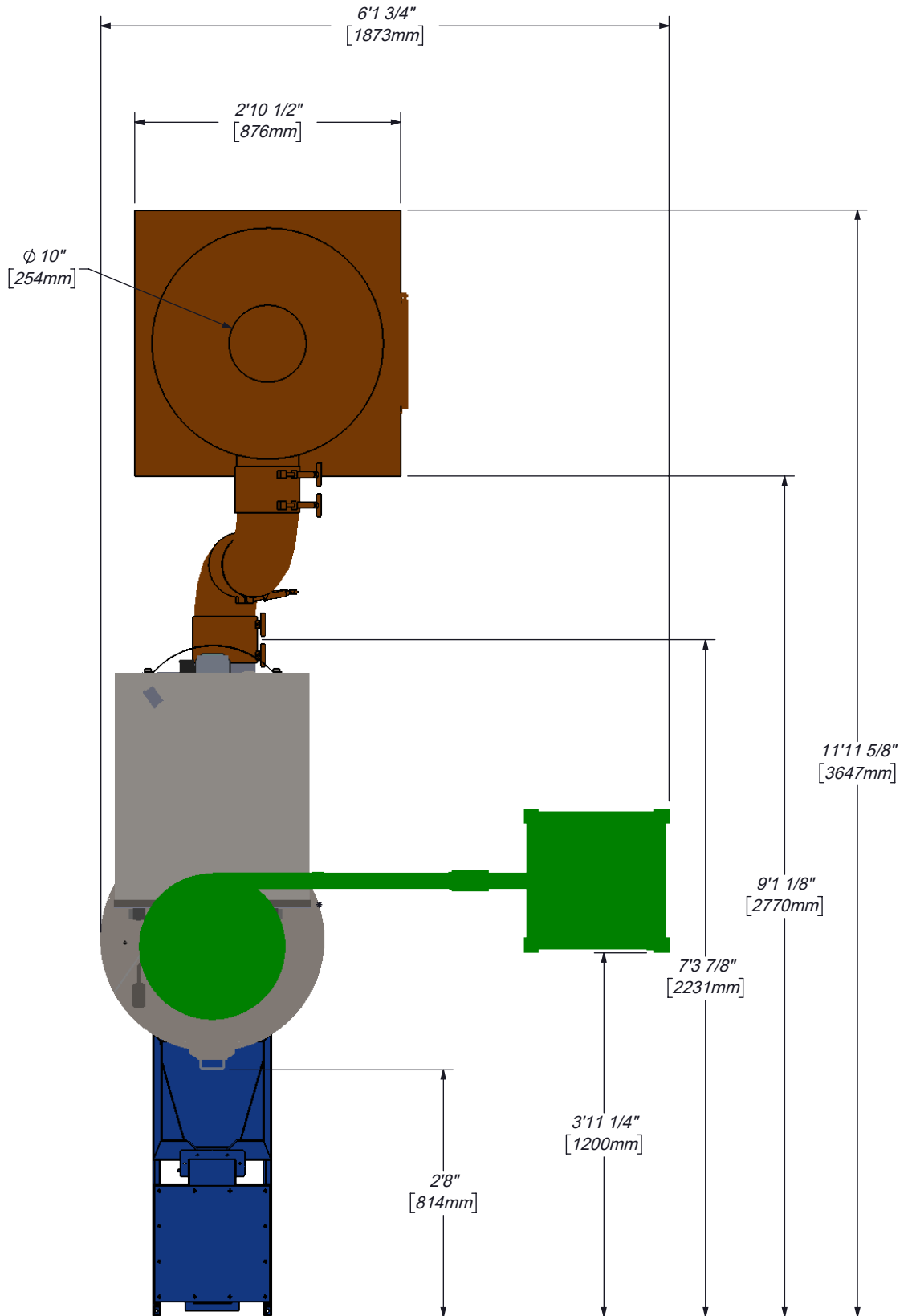

Top View - Full Roasting System

Scale 1:20

3 FACILITY AND INSTALLATION PREPARATIONS

- 3.1 Review the Installation and Operation Manual upon purchase. Read it thoroughly prior to installation of the roaster and/or ancillary equipment.
- 3.2 Check local building/fire codes and regulations. Local regulations and requirements will govern in the event they exceed or contradict information provided by Diedrich Roasters LLC, in this document or elsewhere.
 - 3.2.1 It is the purchaser's responsibility to ensure the appropriate codes and regulations, specific to their area, are followed and met.
- 3.3 Obtain any required permits such as building and air quality permits. Requests for information or assistance with permitting and/or certification forms must be submitted to Diedrich within 30 days of purchase. Anticipate approximately 15 business days from submittal of forms for Diedrich to complete our part.
- 3.4 Determine the layout/location of the roaster and any ancillary equipment.
 - 3.4.1 Clearance to combustibles must be a minimum of 18 inches (457 mm) from the sides and the back of the roaster, as well as from the exhaust pipe stub. However, 3-4 feet (1-1.2 meters) minimum clearance is recommended for operation, maintenance, and repairs. See the Top View Space and Utility Connection Information drawing.
 - 3.4.2 Diedrich Roasters personnel may assist with a customized layout to fit within a specified space. This service is primarily available for Diedrich systems with roasters and other ancillary equipment.
- 3.5 Seek licensed and certified professionals for preparation, installation, and connection of electrical, gas, and exhaust ducting to the roaster and any ancillary equipment.
- 3.6 Make sure the appropriate electrical power is available. Ancillary equipment such as the loader, destoner, and afterburner will require their own power source, since they are not powered by the roaster. See section 1 of this document and the Installation and Operation Manual for additional information.
- 3.7 Make sure the appropriate gas supply is available. See section 1 of this document and the Installation and Operation Manual for additional information.
- 3.8 The roasting system will remove fresh air from the building. An additional fresh air inlet may be required to allow "make up air". See section 1 of this document for roaster airflow information. Consultation with a licensed Heating, Ventilation, and Air Conditioning (HVAC) contractor is recommended.
- 3.9 Ensure the appropriate size and type of exhaust ducting is installed. Section 1 of this document, and the "Exhaust Ducting" section below, provide technical data and other pertinent information. *The exhaust ducting can be expensive and have a long lead time.*

4 EXHAUST DUCTING

- 4.1 One of the most important aspects of the roaster installation is the use of an approved exhaust ducting system. Its design will greatly affect the performance of the roaster and the product quality. The cost and time to order and install the exhaust ducting are important factors for the customer to consider.
- 4.2 Designing the exhaust system requires a trained professional to calculate the efficiency of the system and the proper size of ducting. The ducting must be of sufficient diameter to accommodate the air flow (SCFM - standard cubic feet per minute or SCMh - standard cubic meters per hour) and meet the static pressure requirement (noted below). A licensed engineer or Heating, Ventilation, Air Conditioning (HVAC) professional can assist you with the best ducting layout for your site. Pertinent information the contractor will need, such as the diameter of the exhaust ducting on the roaster and the maximum exhaust air flow in SCFM, is located in the section 1 *Technical Data* table.
- 4.3 All makes of roasters and afterburners have a blower which forces exhaust air into the ducting. The oils and residues in the roaster exhaust air are flammable. In the event of a ducting/flue fire, the internal duct temperatures can exceed 1000° F (538°C), which could cause nearby combustible materials to ignite. For this reason, Diedrich recommends, at a minimum, stainless steel, double wall, positive pressure grease ducting that meets the applicable region/local standards, such as UL for the USA, ULC for Canada, and CE for the European Union.
- 4.4 For Roasters (with or without cyclones).
 - 4.4.1 Ducting must be suitable for 500°F (260°C) continuous, 2,000°F (1,093°C) for 30 minutes, and comply with UL-1978/ULC-SC662 Standard for Grease Ducts in the USA/Canada, and/or equivalent standards for other countries (such as CE standards for the European Union).
 - 4.4.2 Installation must be done in accordance with appropriate NFPA standards in the USA or equivalent standards in other countries. The installation must also comply with the manufacturer's installation specifications and allowable distance to combustible/noncombustible materials.
- 4.5 For Roasters with an Afterburner.
 - 4.5.1 Ducting from the Afterburner must be suitable for 1,000°F (538°C) continuous, 1,400°F (927°C) intermittent, and comply with UL-103/ULC_ORD-C959 in the USA/Canada, and/or equivalent standards for other countries (such as CE standards for the European Union).
 - 4.5.2 Installation must be done in accordance with appropriate NFPA standards in the USA or equivalent standards in other countries. The installation must also comply with the manufacturer's installation specifications and allowable distance to combustible/noncombustible materials.

- 4.6 There are companies that offer ducting products that meet both of the standards noted above (UL 1978 and UL 103). Some of these companies are listed below along with their websites and contact information.

Van-Packer www.vpstack.com; 888-877-8225, and/or VPTech@vpstack.com

Selkirk www.selkirkcorp.com and/or customer service at 800-848-2149

Jeremias www.jeremiasinc.com and/or e-mail Cayce.raper@jeremiasinc.com

DuraVent www.duravent.com and/or e-mail customerservice@duravent.com

- 4.7 Another consideration when designing an exhaust ducting system is the static pressure. The static pressure is the backpressure or suction within the system. The exhaust system must be designed to operate with a static flue pressure between negative 0.15"WC (negative pressure – suction) and positive 0.25"WC (backpressure) at the exhaust of the roaster (cyclone or Afterburner, as applicable) while in operation.
- 4.7.1 When venting your roaster, a direct vertical run is typically the most efficient and cost effective. Long horizontal runs and elbows will put a restriction on the airflow which may cause excessive backpressure. A booster fan may be needed to assist air movement if the system is too restrictive. A qualified ducting contractor/engineer should determine the best design for your specific installation.
- 4.8 A properly designed and installed chimney and rain cap is essential to the equipment performance and longevity. Water leaking in may cause an electrical short or damage the equipment. Your contractor will be able to coordinate with local jurisdictions for the correct cap. The cap should not have a screen since it will clog with residue of chaff over time.
- 4.9 The roaster (cyclone or Afterburner, as applicable) MUST NOT support the weight of the exhaust system. Ducting must be connected to the roaster based on the ducting manufacturer's recommendation.



DANGER

DO NOT USE CLASS B OR SPIRAL-WRAP DUCTING UNDER ANY CIRCUMSTANCES.



DANGER

Fires are caused by failure to maintain a clean roaster and its exhaust ducting system. Regular cleaning of the roaster and exhaust ducting will prevent the buildup of residues that could cause fire.

5 ADDITIONAL DOCUMENTS AND INFORMATION

The information in this document is intended to assist customers with purchasing and facility preparation decisions. Upon purchase of a Diedrich Roaster, additional documentation will be provided. It is important for customers to read these documents in order to ensure that the installation and operation phases are smooth and safe.

Please feel welcome to reach out to us with questions or information requests.

Phone: 844-343-3742

E-mail: Support@DiedrichRoasters.com

Website: DiedrichRoasters.com

Facebook: [Facebook.com/DiedrichRoasters](https://www.facebook.com/DiedrichRoasters)

Instagram: [Instagram.com/DiedrichRoasters](https://www.instagram.com/DiedrichRoasters)

Released June 2019