

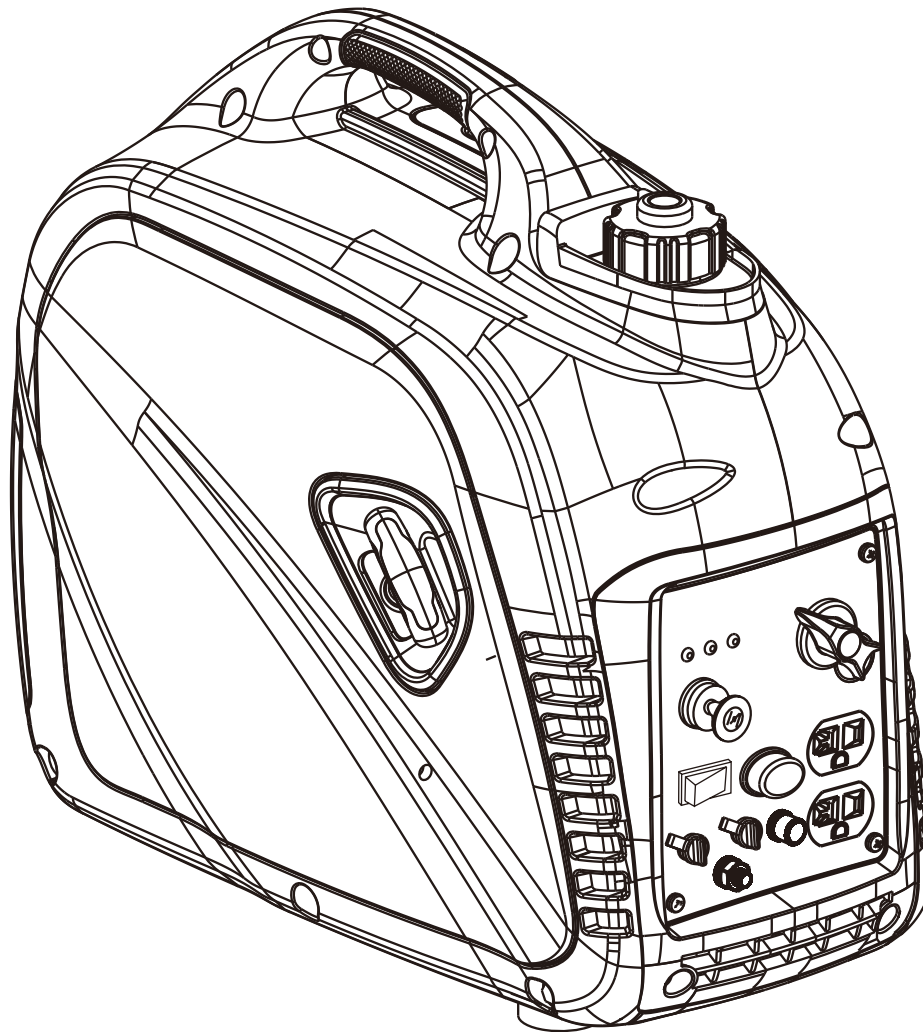

Model: PG2200BiS

Inverter Gasoline OPERATOR'S MANUAL



Warning: The Engine Exhaust from this product contains chemicals known to the State of California to cause cancer, birth defects or other reproductive harm.

support@pulsar-products.com

TABLE OF CONTENTS

| | |
|---|-----------|
| Introduction | 3 |
| Product Specifications..... | 3 |
| Parts Ordering / Customer Service..... | 3 |
| Safety Rules | 4 |
| Safety Symbols..... | 4 |
| Safety Instructions | 4 |
| Features | 7 |
| Control Panel Functions | 8 |
| ON/OFF Start Switch and Choke..... | 8 |
| USB Outlet | 8 |
| Indicator Lights..... | 8 |
| DC Protector..... | 9 |
| Engine “Economy” Control | 9 |
| Parallel Outlets..... | 10 |
| Fuel Cap Air Vent..... | 10 |
| Ground Terminal..... | 10 |
| Assembly | 11 |
| Connecting Generator to an Electrical System..... | 11 |
| Adding Fuel..... | 11 |
| Adding / Checking Oil | 12 |
| Operation | 13 |
| Grounding the Generator..... | 13 |
| How to Start Engine..... | 13 |
| How to Stop Engine..... | 14 |
| Attaching Electronic Devices..... | 14 |
| Charging a 12 Volt Battery..... | 15 |
| AC Parallel Operation..... | 16 |
| Don’t Overload Generator..... | 17 |
| Wattage Reference Guide..... | 17 |
| Maintenance | 18 |
| Maintenance Schedule | 18 |
| Checking Spark Plug | 19 |
| Changing Oil | 20 |
| How to Clean Air Filter..... | 21 |
| Checking Muffler and Spark Arrestor | 21 |
| How to Clean Fuel Filter | 22 |
| Transport & Storage | 22 |
| Troubleshooting | 24 |
| Specifications | 25 |
| Noise | 25 |
| Warranty | 30 |

INTRODUCTION

Thank you for purchasing this superior quality portable generator from PULSAR PRODUCTS INC. When operating and maintaining this product as instructed in this manual, your generator will give you many years of reliable service.

Product Specifications:

This generator is an engine-driven, portable generator. It is designed to supply electrical power to operate tools, appliances, camping equipment, lighting, or serve as a back up power source during power outages.

| | | |
|-----------|---------------------|--|
| AC Output | Rated AC Voltage | 120V |
| | Rated Frequency | 60Hz |
| | AC Current | 15A |
| | Rated Output | 1800W |
| | Maximum Output | 2200W |
| Engine | Displacement | 80cc |
| | Engine Type | Single cylinder, 4 Stroke, OHV, Air Cooled |
| | Engine Oil Type | SAE 10W30 |
| | Engine Oil Capacity | 350ml / 11.8oz |
| | Fuel Tank Capacity | 4.5L / 1.18Gal |

The emissions control system for this generator is compliant with all standards set by the Environmental Protection Agency.

How to contact us:

You can contact us by Telephone: 1.866.591.8921, Email: support@pulsar-products.com, or write to us at:

PULSAR PRODUCTS.INC.
5721 santa Ana st Unit A
Ontario, California, U.S.A. 91761

Record the following information below for service or warranty assistance.

| | |
|-------------------|--|
| Date of Purchase: | |
| Model Number: | |
| Serial Number | |

SAFETY RULES

Safety Symbols



WARNING!

Indicates a potentially hazardous situation which could result in serious injury or death if not avoided.



CAUTION!

Indicates a potentially hazardous situation which could result in damage to equipment or property.



Toxic Fumes



Risk of fire



Risk of explosion



Risk of electric shock



Hot surface

Safety Instructions

The manufacturer cannot anticipate every possible hazardous circumstance that the user may encounter. Therefore, the warnings in this manual, on tags, and on affixed decals are not all-inclusive. To avoid accidents, the user must understand and follow all manual instructions and use common



WARNING!

Read and understand this manual in its entirety before operating this generator. Improper use of this generator could result in serious injury or death.



WARNING!



Do not operate indoors or in a confined space preventing dangerous carbon monoxide gas from dissipating.

- Using a generator indoors **WILL KILL YOU IN MINUTES!**
- Carbon monoxide gas is a poisonous, odorless gas that can cause headache, confusion, fatigue, nausea, fainting, sickness, seizures, or death. If you start to experience any of these symptoms, **IMMEDIATELY** get fresh air and seek medical attention.
- **Never use indoors, in a covered area, or in a confined space, even if doors and windows are open.**
- Install a battery operated carbon monoxide alarm near bedrooms.
- Keep exhaust from this unit from entering a confined area through windows, doors, vents, or other openings.
- When working in areas where vapors could be inhaled, use a respirator mask according to all of its instructions.



WARNING!

Engine exhaust contains chemicals that lead to cancer and cause birth defects.

- Always wash hands after handling generator.

SAFETY RULES



WARNING!

Never exceed generators wattage / amperage capacity. This could damage the generator and / or connected electrical devices.

- Check operating voltage and frequency requirements of all electrical devices prior to plugging them into the generator.



WARNING!

Never start or stop engine with electrical devices plugged in to the receptacles. Failure to do so could damage the generator and / or connected electrical devices.

- Always start the engine and let it stabilize before connecting any electronic devices.
- Disconnect all electronic devices before stopping the engine.



WARNING!

Starter and other moving parts can catch on clothing, jewelry, and hair.

- Do not wear loose clothing or gloves.
- Remove jewelry or anything else that could be caught in moving parts.
- Tie back or wear protective head covering to contain long hair.



WARNING!



Keep engine away from flammable objects and other hazardous materials.

- The fuel and its vapors used to power this unit are highly flammable and could explode resulting in serious injury or death.
- Never fill or drain fuel tank indoors.
- Never overfill fuel tank. If fuel spills, move the unit at least 30 feet away from the spill and wipe up any remaining fuel on the unit before starting the engine.
- Never smoke while operating or fueling this unit.
- Never operate or store this unit near an open flame, heat, or any other ignition source.
- Generator should have at least 5 feet of clearance from buildings or other equipment during operation.
- Keep engine free of grass, leaves, or grease which are flammable.
- When adding or draining fuel, unit should be turned off for at least 2 minutes to cool before removing fuel cap. If unit has been running then the fuel cap is under pressure, remove slowly.
- To keep fuel from spilling, secure unit so it cannot tip while operating or transporting.
- When transporting unit, disconnect the spark plug wire and make sure the fuel tank is empty with the 3 in 1 switch is turned to the off position.



WARNING!

Pull cord recoils rapidly and pulls arm towards engine faster than you can let go which could result in injury.

- To avoid recoil, pull starter cord slowly until resistance is felt, then pull rapidly.



WARNING!



Avoid contacting hot areas of this unit.

- Use caution around the muffler, cylinder, and other engine parts as they can be extremely hot.
- Allow hot components to cool before touching.

SAFETY RULES



WARNING!



This generator produces a very high voltage which could result in burn or electrocution causing serious injury or death.

- Never handle the generator, electronic devices, or any cord while standing in water, while barefoot, or when hands or feet are wet.
- Always keep the generator dry. Never operate generator in rain or under wet conditions.
- Use a ground fault circuit interrupter (GFCI) in a damp or highly conductive area, such as metal decking or steel work.
- Never plug electronic devices into generator having frayed, worn, or bare wires. Never touch bare wires or make contact with receptacles.
- Never permit a child or unqualified person to operate generator. Keep children a minimum of 10 feet away from the generator at all times.
- If using the generator for back up power, notify the utility company.
- If connecting generator to a building's electrical system for standby power, you must use a qualified electrician to install a transfer switch. Failure to isolate the generator from the power utility could result in serious injury or death to electric utility workers.



WARNING!



Generator must be properly grounded to prevent electrocution.

- Only operate generator on a level surface.
- Always connect the nut and ground terminal on the frame to an appropriate ground source.



WARNING!

Never modify this unit in any way or modify governed speed.

- Increasing governing speed is dangerous which can result in personal injury and / or damaged equipment.
- Decreasing governing speed adds an excessive load and can damage equipment.
- Only when operating at the preset governing speed will this generator supply the correct rated frequency and voltage.



WARNING!

Only use this unit as it is intended or serious injury or death could result.

- Do not bypass any safety device. Moving parts are covered with guards. Make sure all protective covers are in place.
- Never transport or make adjustments to this unit while it is running.
- Never insert objects through cooling slots.



WARNING!

Never operate this unit if there are any broken or missing parts and only use PULSAR PRODUCTS INC. replacement parts specifically designed for this unit.

- Improper treatment of generator can damage the unit and shorten its life.
- Always repair this unit as specified in this manual. If you have any questions contact your dealer or consult a qualified service center.
- Shut generator off if electrical outpost is missing, unit vibrates excessively or begins to smoke, spark or emit flames.

PROP 65 WARNING: This product contains chemicals known to the state of California to cause cancer and birth defects or other reproductive harm.

FEATURES

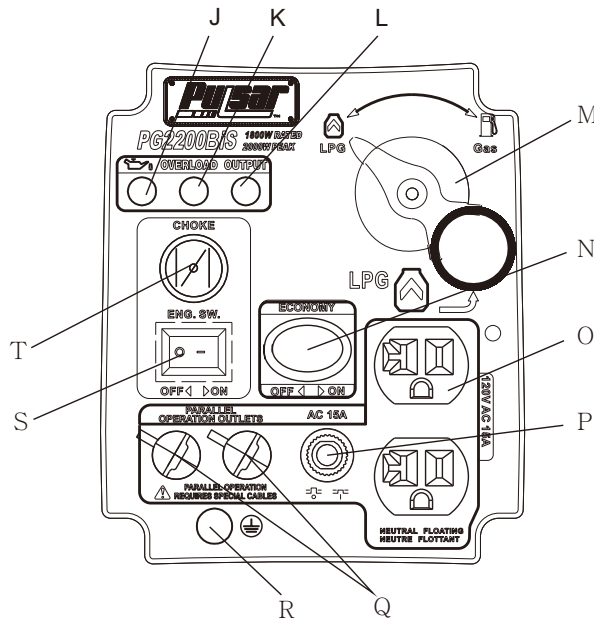
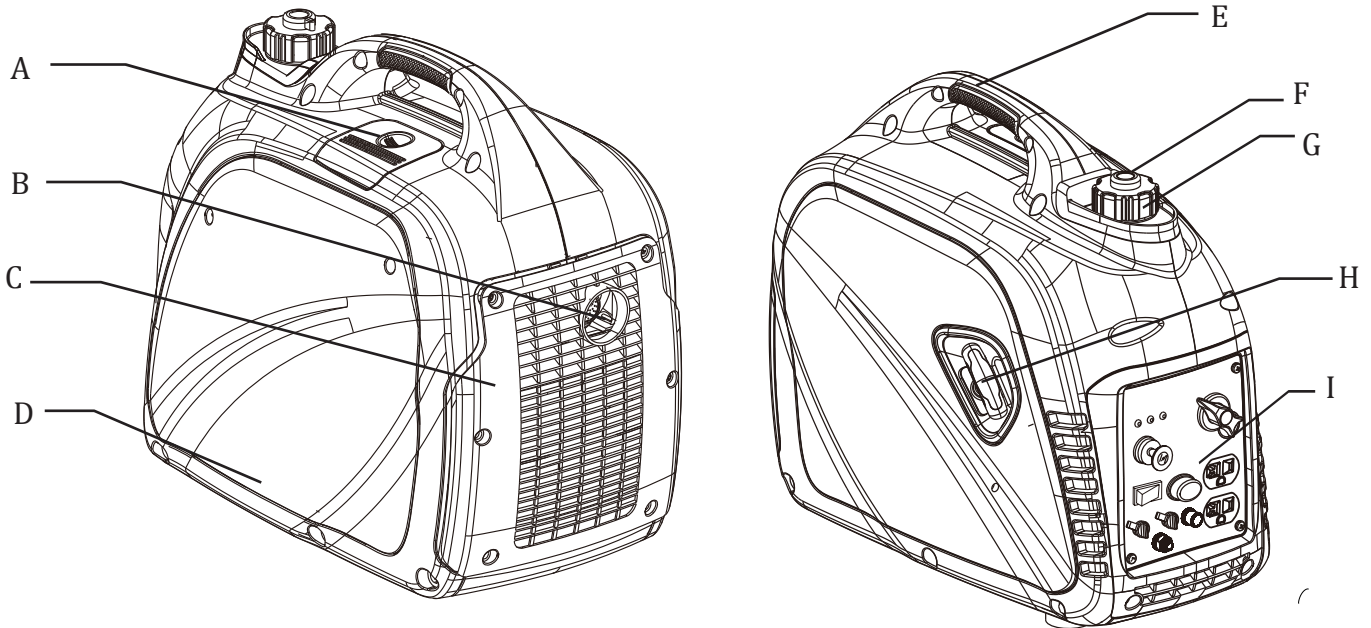

- A - Spark Plug Cover
- B - Spark Arrestor
- C - Muffler Cover
- D - Outer Casing (Side Panel)
- E - Handle (Grip)
- F - Air Vent
- G - Fuel Cap
- H - Recoil Starter

- I - Control Panel
- J - Oil Warning Light
- K - Overload Indicator Light
- L - AC Pilot Light
- M - Fuel Selector
- N - Power Switch
- O - 120V AC 15A Duplex Outlet
- P - AC 15A Circuit Breaker
- Q - Parallel Outlets
- R - Ground Terminal
- S - Engine Switch
- T - Choke

CONTROL PANEL FUNCTIONS

Fuel Selector Switch

When the Switch is in the Gas position and the Gasoline is "On", the generator is ready to start on Gasoline.

When the Switch is in the LPG position and the Gasoline is "Off", the generator is ready to start on LPG.

Choke Lever

When starting the generator on gasoline, pull out the "Choke" lever to allow the unit to start. Once started, push the choke back in to allow the unit to run normally.

Note: The Choke is not required to start a warm engine

Oil Warning Indicator Light

When the oil falls below the minimum level, the oil warning indicator light comes on and the engine stops automatically. The engine will not start until the proper amount of oil is in the crank case.

Note: If the oil warning indicator light does not come on and the engine stalls, turn the Start Switch to "RUN" and pull the recoil starter.

Engine Overload Indicator Light

If the engine overload indicator light comes on, the generator's wattage / amperage capacity has been exceeded by connected electrical devices or by a power surge. When this occurs, the green AC Pilot Indicator Light will go off. The engine will continue to run, (but the red Engine Overload Indicator Light will stay on and power will no longer be supplied to connected electronic devices.)

How to Correct

1. Disconnect any electronic devices then stop the engine.
2. Reduce the total wattage of connected electronic devices until it is within the generator's rated output.
3. Inspect the Air Inlet and Control Panel for any blockage. Remove blockage if found.
4. Restart Engine.

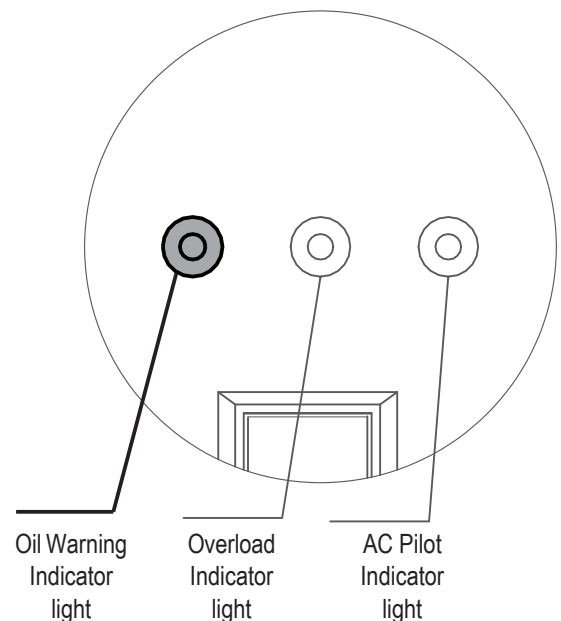

CONTROL PANEL FUNCTIONS

Note: The engine overload indicator light may turn on for a few seconds when attaching a load due to a power surge. This is normal.

AC Pilot Indicator Light

The green AC Pilot Indicator Light comes on when the engine starts and generates power.

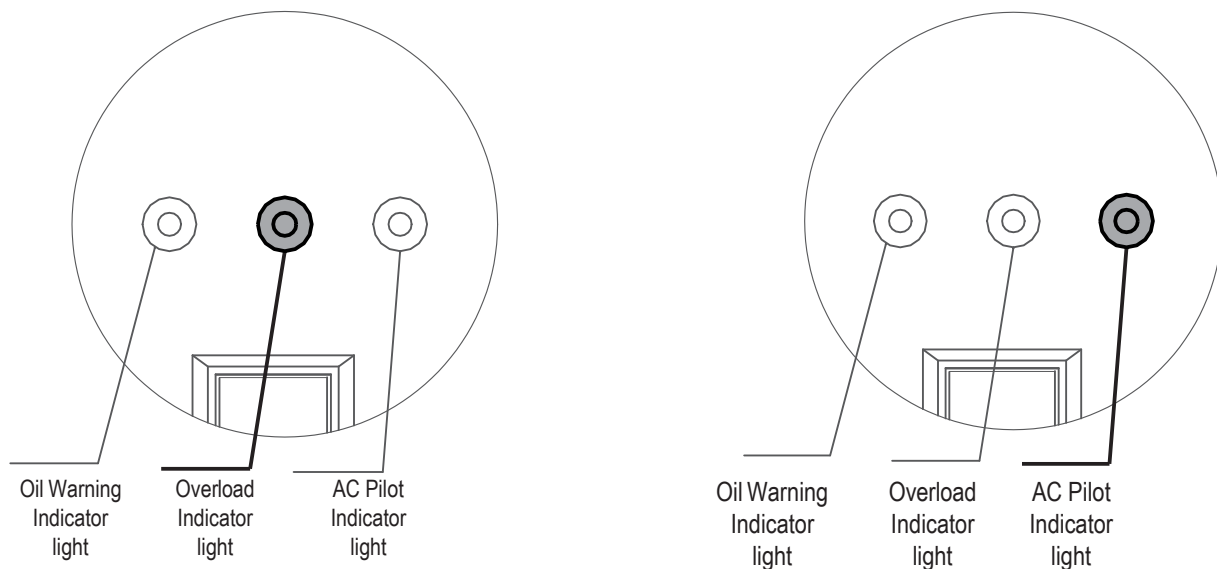

Engine Economy Control

- When the Engine Economy switch is turned to the "ON" position, the economy control unit automatically determines the generator's proper engine speed based on the connected electronic load. This results in superior fuel economy and reduces noise.
- When the Economy switch is turned to the "OFF" position, the engine runs at the rated speed of 4,100 r/min.

CONTROL PANEL FUNCTIONS

Note: The Economy switch must be turned to the “OFF” position when using electronic devices that require a large starting current, such as a compressor.

Parallel Outlets

Located just above the Ground Terminal, the generator’s Parallel Outlets enable a user to run two PG2000BiSR generator’s simultaneously. This operation requires special cables. When operating parallel generators, the rated output is 3.0kVA and the rated current is 25A/120VAC. For cables and instructions consult a PULSAR dealer for a PARALLEL OPERATION CABLE KIT.

 **WARNING!** Never connect generators that are different models.

- Only connect this generator to another PG2000BiSR Standard Generator.
- Only use a parallel operation cable kit designed to work with this Generator.

Fuel Cap

Turn counterclockwise to remove the fuel cap.

Fuel Cap Air Vent

The fuel cap is equipped with an air vent to stop fuel from flowing to the carburetor. The Air Vent must be in the “ON” position to allow fuel to flow so that the engine can run. Turn the Air Vent to the “OFF” position to stop fuel flow.

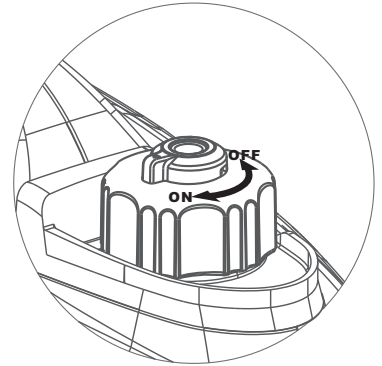

Ground Terminal

The generator’s ground terminal must always be used to connect the generator to a driven ground rod. Connect the ground terminal to the driven ground rod with a 12 AWG (American Wire Gage) copper wire. The wire connects to the terminal between the lock washer and nut. Tighten the nut securely to ensure good connection. Grounding the generator protects you from electric shock that results from a build up of static electricity or undetected ground faults.

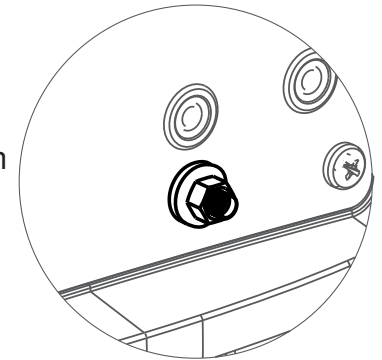

 **WARNING!**  Generator must be properly grounded to prevent electrocution.

- Only operate generator on a level surface.
- Always connect the nut and ground terminal on the frame to an appropriate ground source.

ASSEMBLY

Connecting Generator to an Electrical System

- If connecting generator to a building's electrical system for standby power, you must use a qualified electrician to install a transfer switch. The power from the generator must be isolated from the circuit breaker or alternative power source. The connection must comply with all electrical codes and applicable laws.

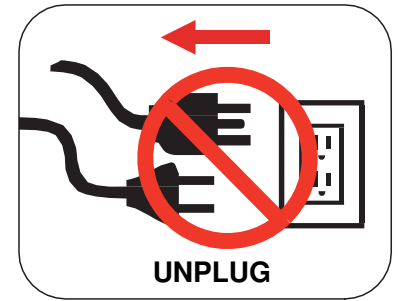

Never directly connect generator to a household power source.



WARNING!



This generator produces a very high voltage which could result in burn or electrocution causing serious injury or death.

- Never handle the generator, electronic devices, or any cord while standing in water, while barefoot, or when hands or feet are wet.
- Always keep the generator dry. Never operate generator in rain or under wet conditions.
- Use a ground fault circuit interrupter (GFCI) in a damp or highly conductive area, such as metal decking or steel work.
- Never plug electronic devices into generator having frayed, worn, or bare wires. Never touch bare wires or make contact with receptacles.
- Never permit a child or unqualified person to operate generator. Keep children a minimum of 10 feet away from the generator at all times.
- If using the generator for back up power, notify the utility company.
- If connecting generator to a building's electrical system for standby power, you must use a qualified electrician to install a transfer switch. Failure to isolate the generator from the power utility could result in serious injury or death to electric utility workers.

Adding Fuel

- Set generator on a clean and level surface in an area that is well ventilated.
- Remove fuel cap.
- Insert a funnel into the fuel tank and carefully pour gasoline into the tank until fuel level reaches about 1 ½ inches below the top of the neck. Be careful not to overfill the tank to provide space for fuel expansion.
- Replace fuel cap and secure tightly.

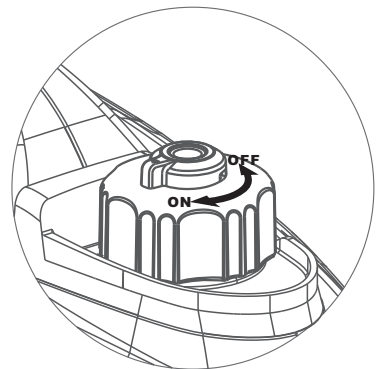

Turn cap counterclockwise to remove.

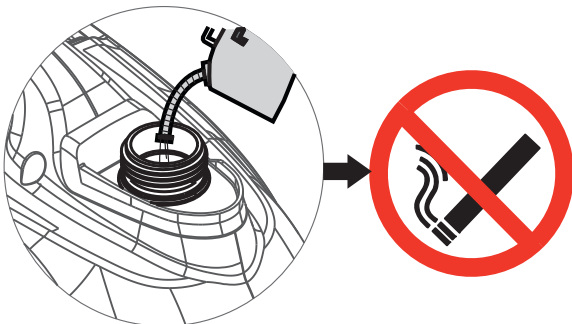

Do not smoke when adding fuel.

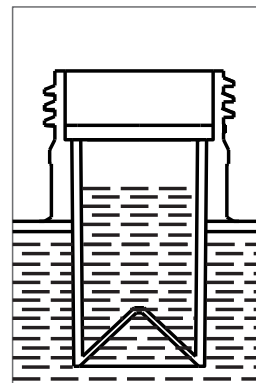

Do not overfill the fuel tank.
Provide space for fuel expansion.

ASSEMBLY

Adding /Check ing Engine Oil

- Place generator on a level surface.
- Remove screws and then remove the outer casing cover.

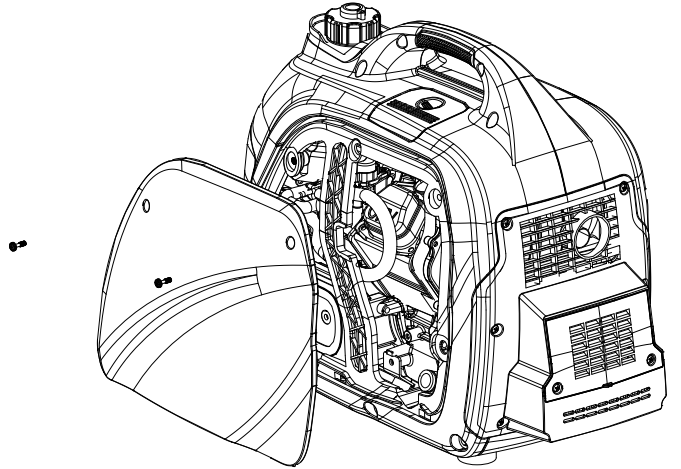

- Remove the crankcase dipstick.

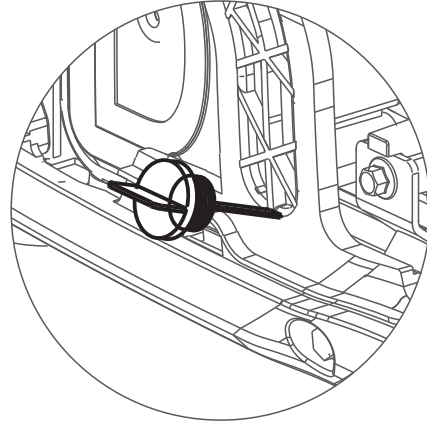

- Insert a funnel into the crankcase dipstick hole and carefully add the specified amount of 4-Cycle engine oil (SAE 10W-30) to empty reservoir until or oil reaches the outer edge of the oil fill hole (crankcase dipstick hole).
- Be sure to replace dipstick and securely tighten before attempting to start the engine.
- To check oil, set generator on a level surface, wipe dipstick clean, then reinsert dipstick without re-threading.

Recommended Oil: SAE 10W-30

Oil Capacity: 0.35L (11.8oz)



CAUTION!

Generator has been shipped without engine oil. You must add oil before first operating this generator. Always check oil level before each operation.

OPERATION

Grounding the Generator

To avoid electrocution, this generator must be properly grounded prior to use. For instructions see Control Panel Functions pg. 10.

Standard Atmospheric Conditions

Ambient Temperature: 77°F (25°C)

Barometric Pressure: 100kPa

Relative Humidity: 30%

Generator output will vary due to changes in temperature, altitude, and humidity. If the temperature, humidity, or altitude are higher than standard atmospheric conditions, the generator's output will be reduced. The load attached to the generator must therefore be reduced.

How to Start Engine on Propane

- Place generator on a level surface. All electrical loads **MUST** be disconnected from generator.
- Turn the ENG. SW. to "ON"
- Turn the fuel selector fully left to "LPG"
- Screw the Propane hose to the Panel Propane Connection
- **DO NOT** Pull the choke lever out.
- Turn on the propane supply.
- Press the decompression valve button for 3 to 5 seconds.
- Pull recoil handle (starter cord) slowly until resistance is felt, then pull rap



WARNING!

Pull cord recoils rapidly and pulls arm towards engine faster than you can let go which could result in injury.

- To avoid recoil, pull starter cord slowly until resistance is felt, then pull rapidly.

Note: To start the generator with the Economy switch in the "ON" position

- Disconnect all electrical loads from generator.
- If ambient temperature is below 32°F (0°C) allow about 3 minutes for the engine to warm up.
- The Economy is in "ON" position, the unit returns to normal operation after the above warm up time.
- Economy switch must be turned to the "OFF" position when using electronic devices that require a large starting current, such as a compressor.

OPERATION

How to Stop Engine

- Turn the Economy switch to the “OFF” position.
- Disconnect any electronic device. All loads **MUST** be disconnect from the generator. Never start or stop the engine with electrical devices plugged in to the receptacles.
- Turn the Start Switch to the “OFF” position.
- Turn the fuel supply to the “OFF” position.



CAUTION!

If you choose one push start key or remote control to stop the generator, please press the power switch to "OFF" position at the end.



WARNING!

Never start or stop engine with electrical devices plugged in to the receptacles. Failure to do so could damage the generator and / or connected electrical devices.

- Always start the engine and let it stabilize before connecting any electronic devices.
- Disconnect all electronic devices before stopping the engine.

How to Attach Electronic Devices

1. Before Starting generator
 - Make sure the generator is grounded (see page 10 for instructions).
 - Make sure the attached load is within the generator rated output and the receptacle’s rated current.
 - Make sure all electrical cords and receptacles are in good condition.
 - Make sure all electronic devices are turned “OFF” before plugging them into the generator.
2. Start engine
3. If the attached load is small, turn the Economy switch to the “ON” position. For a larger load, or if attaching multiple electronic devices turn the Economy switch to the “OFF” position.
4. Make sure the green AC pilot indicator light is on.
5. When engine has stabilized, plug in and turn on first load. It is strongly recommended to plug in devices with the largest output first and the smallest output last to help prevent overloading the generator.
6. Allow generator output to stabilize (engine and attached devices run evenly) before plugging in the next load.

OPERATION

Charging a 12 Volt Battery

This generator can be used to charge a 12 volt automotive or storage battery by taking the following steps:

Inspect fluid level of the battery cells. Add ONLY distilled water to any cell where fluid level is low. Never add tap water.

1. Use a wire brush to clean battery terminals if corroded.
2. Securely connect the red cable clamp to the positive (+) battery terminal.
3. Securely connect the black cable clamp to the negative (-) battery terminal.
4. Turn the Economy switch to the "OFF" position to start battery charging.
5. Battery is considered fully charged when the gravity of its fluid is between 1.26 and 1.28 when measured by a hydrometer.

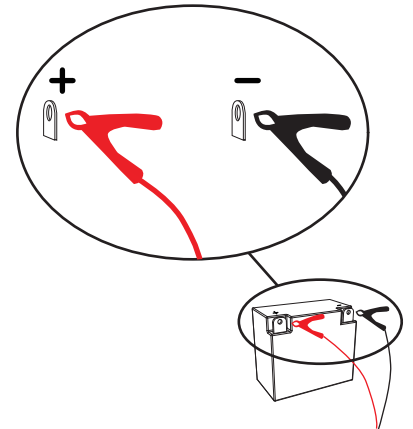

Note: It is strongly recommended to check the gravity level of the electrode at least once per hour with a hydrometer to prevent overcharging and to test the battery's condition. Be careful to follow the hydrometer manufacture's instruction.



WARNING!



Battery electrolyte is poisonous and dangerous.

- Do not disconnect battery clamps while charging. Batteries produce explosive gasses. Disconnecting the battery clamps while charging could spark and ignite.
- Do not charge battery in an enclosed area.
- Never smoke while charging the battery or operating or fueling this generator.
- Battery electrolyte contains sulfuric acid. Avoid contact with skin, eyes, and clothing. Always wear eye protection when charging battery.
- If battery acid contacts skin, flush with water immediately. If it contacts eyes, flush with water for 15 minutes and get immediate medical attention. For internal ingestion, drink large quantities of water or milk, followed by milk of magnesia, beaten egg, or vegetable oil. Contact a medical physician immediately.

OPERATION

AC Parallel Operation

It is possible to connect two PG2000BiSR generators to each other, using a parallel cable kit, to increase available power

- Connect PARALLEL OPERATION CABLES to two PG2000iS generators according to the instructions provided with the cable kit.
- Make sure the Economy switch is in the same position on both generators.
- All electronic devices should be turned “OFF” and disconnected from generators prior to starting generator engines.
- Start generator engines. Make sure the green output indicator light comes on for each generator.
- When engines have stabilized, plug in electronic device to AC receptacle and turn on first load.
- Allow generator output to stabilize (engine and attached devices run evenly) before plugging in the next load.

Maximum Power in Parallel Operation: 4.0kVA

Rated Power in Parallel Operation: 3.0kVA

Limit operation time to 3 seconds for load requiring maximum output. For continuous operation, do not exceed the rated output.

Note: It is strongly recommended to plug in devices with the largest output first and the smallest output last to help prevent overloading the generator.

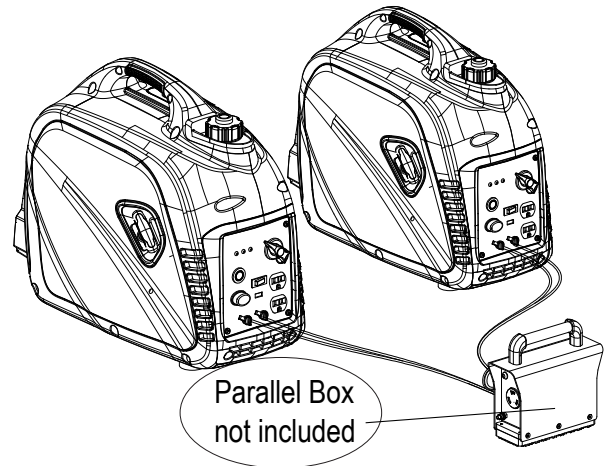

Note: Most electronic devices require power beyond its rated wattage to start. This additional power is referred to as surge watts and usually lasts between 2-3 seconds. When an electronic device is started, the red overload indicator may come on. This is normal. If the light stays on disconnect all electronic devices and stop the engine. Refer to “Engine Overload Indicator Light” on page 8.



CAUTION!

NOT FOR INTERRUPTING CURRENT and ATTENTION: NE PAS UTILISER POUR COUPER LE COURANT.



WARNING!

Only connect electronic devices to the generator that are in good working order and do not exceed the rated power supply of the parallel generators or the desired receptacle.

- A faulty appliance or power cord can create an electric shock. Do not use electronic devices that have a damaged cord or plug.
- If an appliance begins to operate abnormally, becomes sluggish, or stalls, turn off and disconnect appliance immediately. The appliance may have a fault or its rated load capacity exceeds the power supply of the generator.
- To avoid damage to generator or electronic device, do not connect a load to the generator if its electrical rating exceeds that of the receptacle.



WARNING!

Never connect generators that are different models.

- Only connect this generator to another PG2000BiSR Generator.
- Only use a PULSAR approved parallel operation cable kit to connect generators.
- Do not run generators in parallel operation in excess of 30 minutes.
- The parallel cable must be removed if operating only one generator.
- Never disconnect or remove the parallel operation cable while generator is still running.

OPERATION

Don't Overload Generator

Make sure you can supply enough rated watts for all electronic devices connected to the generator. Rated watts refer to the power a generator must supply to keep a device running. Surge watts refer to the power a generator must supply to start an electronic device. This power surge for starting a device usually lasts between 2-3 seconds but this additional output must be taken into account when selecting the electronic devices you plan to attach to the generator. To prevent overloading the generator take the following steps:

1. Add up the total rated wattage of all electronic devices that will be connected to the generator simultaneously.
2. Estimate surge watts by adding the item(s) with the highest output (it is unnecessary to calculate the surge output for all devices as they should be connected one at a time).
3. Add the Surge Watts to the total Rated Watts in step 1. Keep total load within generator's power capacity.

Wattage Reference Guide

(Wattages listed are just approximations. Check electronic device for actual wattage)

| Essentials | Rated Watts | Surge Watts |
|---------------------------------|-------------|-------------|
| 75W Light Bulbs | 75 each | 75 each |
| 18 CU Ft Refrigerator / Freezer | 800 | 2200 |
| Furnace Fan (1/3 HP) | 800 | 2350 |
| Sump Pump (1/3 HP) | 1000 | 2000 |
| Water Pump (1/3 HP) | 1000 | 3000 |
| Heating/Cooling | | |
| Dehumidifier | 650 | 800 |
| Table Fan | 800 | 2000 |
| Electric Blanket | 400 | 400 |
| Space Heater | 1800 | 1800 |
| Kitchen | | |
| Blender | 300 | 900 |
| Toaster (2 slice) | 1000 | 1600 |
| Coffee Maker | 1500 | 1500 |
| Electric Range (1 element) | 1500 | 1500 |
| Dishwasher | 1500 | 3000 |
| Laundry Room | | |
| Iron | 1200 | 1200 |
| Washing Machine | 1150 | 3400 |
| Gas Clothes Dryer | 700 | 2500 |

| Bathroom | Rated Watts | Surge Watts |
|-----------------------------------|-------------|-------------|
| Hair Dryer | 1250 | 0 |
| Curling Iron | 1500 | 0 |
| Family Room | | |
| X-Box or Play Station | 40 | 0 |
| AM/FM Radio | 100 | 100 |
| VCR | 100 | 100 |
| Color TV (27") | 500 | 500 |
| Home Office | | |
| Fax Machine | 65 | 0 |
| Personal Computer (17" Monitor) | 800 | 0 |
| Laser Printer | 950 | 0 |
| Copy Machine | 1600 | 0 |
| Power Tools | | |
| 1000W Quartz Halogen Work Light | 1000 | 0 |
| Airless Sprayer (1/3 HP) | 600 | 1200 |
| Reciprocity Saw | 960 | 0 |
| Circular Saw (7 1/4") | 1400 | 2300 |
| Mitar Saw (10") | 1800 | 1800 |
| Table/Radial Arm Saw | 2000 | 2000 |
| Electric Drill (1/2 HP, 5.4 Amps) | 600 | 900 |

MAINTENANCE

Regular maintenance will extend the life of this generator and improve its performance. The warranty does not cover items that result from operator negligence, misuse, or abuse. To receive full value from the warranty, operator must maintain the generator as instructed in this manual, including proper storage.



WARNING!

Before inspecting or servicing this machine, make sure the engine is off and no parts are moving. Disconnect the spark plug wire and move it away from the spark plug.



CAUTION!

If you are unsure of how to perform a maintenance task, have the unit serviced by a PULSAR dealer



CAUTION!

Only use specified PULSAR replacement parts.

Maintenance Schedule

Pre-Operation Steps

Before starting the engine, perform the following pre-operation steps:

- Check the level of the engine oil and the fuel tank level. Check for any leakage.
- Check fuel hose for cracks or damage. Replace if necessary.
- Make sure the air filter is clean.
- Remove any debris that has collected on the generator and around the muffler and controls. Use a vacuum cleaner to pick up loose debris. If dirt is caked on, use a soft bristle brush.
- Inspect the work area for hazards.

After Each Use

Follow the following procedure after each use:

- Shut off engine.
- Store unit in a clean and dry area.

| | |
|-------------------------------|---|
| After First 5 Hours | Change Oil. |
| After 8 Hours or Daily | Clean Debris. |
| | Check Engine Oil Level. |
| 6 Months (100 hr Use) | Check and Clean Air Filter Element. (Service more often under wet or dusty conditions.) |
| | Change Engine Oil. (Service more often under dirty or dusty conditions.) |
| | Check Muffler Screen. Replace if necessary. |
| | Service Spark Plug. |
| | Inspect Muffler and Spark Arrester. |
| 12 Months (300 hr Use) | Clean Fuel Filter. Replace if necessary. |
| | Check Crankcase Breather Hose for cracks or damage. Replace if necessary. |
| | De-carbonize cylinder head. See dealer. |
| | Check and adjust Valve Clearance. See dealer. |
| | Check all Fittings and Fasteners. See dealer. |

MAINTENANCE

Checking Spark Plug

- Remove cap. Then remove spark plug cap.
- Disconnect the spark plug wire from the spark plug.
- Before removing the spark plug, clean the area around its base to prevent debris from entering the engine.
- Insert a spark plug socket wrench through the opening on the outside of the cover. Turn the wrench counterclockwise.
- Check for discoloration and clean carbon deposits off the electrode with a wire brush.
- Check the electrode gap and slowly adjust to 0.6 - 0.7mm (0.024-0.028 in) if necessary.
- Reinstall spark plug and tighten to Torque 20.0Nm (14.8ft-lb).
- If spark plug is worn replace only with an equivalent replacement part. Spark plug should be replaced annually.
- Reconnect spark plug wire.
- Replace spark plug cap, then replace cap.

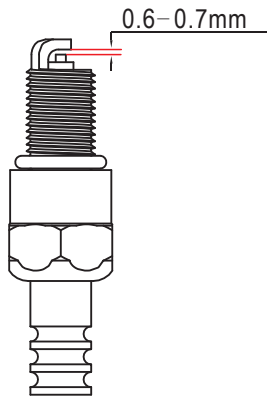
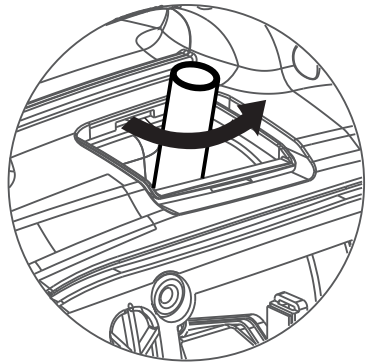
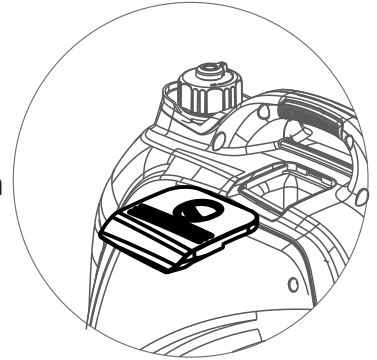

Standard Spark Plug: E6TC/E6RTC/BPR6HS

Spark Plug Gap: 0.6 - 0.7mm (0.024-0.028 in)

Spark Plug Torque: 20.0Nm (14.8ft-lb)

Carburetor Adjustment

The carburetor is low emission and is equipped with a non-adjustable idle mixture valve. If adjustment is needed contact an authorized dealer.

Oil Recommendations

- Do not use special additives.
- Outdoor temperatures determine the proper oil viscosity for the engine. Use the chart to select the best viscosity for the outdoor temperature range expected.

*Note: * Below 40°F (4°C) the use of SAE 30 will result in hard starting.*

*** Above 80°F (27°C) the use of 10W-30 may cause increased oil consumption. Check oil level more frequently*

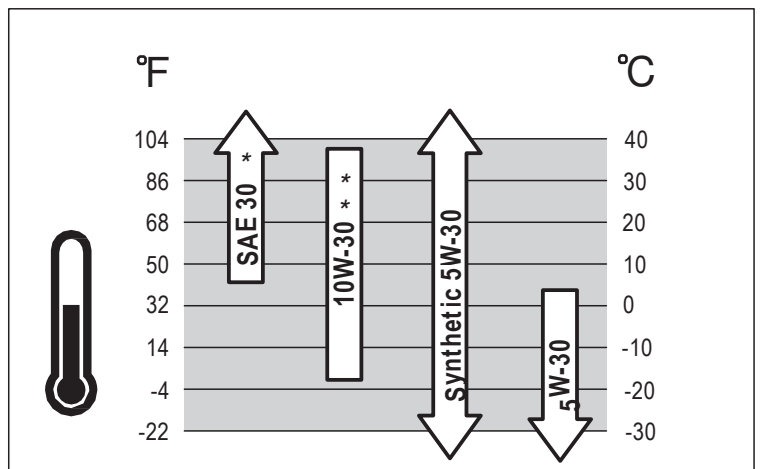

MAINTENANCE

Changing Oil

- Place generator on a level surface.
- Run the generator for several minutes until the engine is warm. Turn off generator.
- Remove screws, then remove outer casing side cover.
- Remove the crankcase dipstick.
- Place an oil pan underneath the engine. Tilt generator to collect used oil. Allow oil to drain completely.
- Return generator to a level surface.
- Carefully add 4-Cycle engine oil (SAE 10W-30) to empty reservoir until oil reaches the outer edge of the oil fill hole (Crankcase Dipstick hole).
- Use a clean rag to wipe up any spilled oil.
- Replace crankcase dipstick.
- Reinstall outer casing side cover and tighten screws.

Recommended Engine Oil: SAE 10W-30

Recommended Engine Oil Grade: API Service SE type or higher quality of engine oil.

Engine Oil Quantity: 0.35L (0.924 US gal)

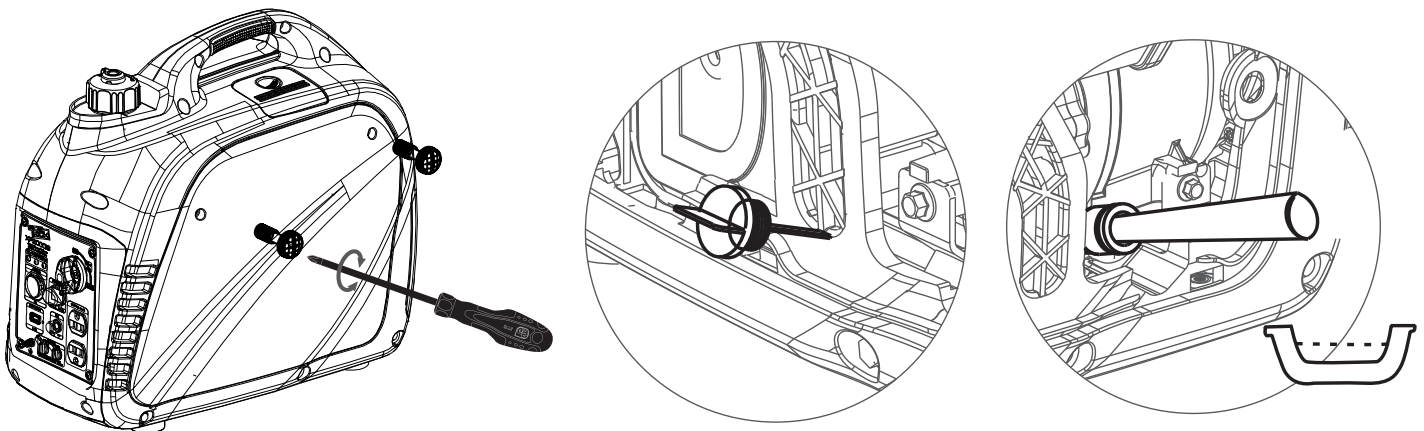

CAUTION!

Do not tilt generator when adding oil. This could result in overfilling which could damage the engine.



CAUTION!

Make sure no foreign matter enters the crankcase

MAINTENANCE

Air Filter

A dirty air filter will reduce the life span of the engine, make it difficult to start the engine, and reduce the unit's performance. Replace with new filter annually.

- To clean, remove the screws then remove outer casing.
- Remove the screws then remove air filter cover.
- Remove the foam element.
- Wash the foam element in solvent and let dry.
- Pour a small amount of oil on the foam element then squeeze out, but do not wring out, excess oil. Foam element should be damp, but not dripping.
- Reinsert the foam element into the air filter case.

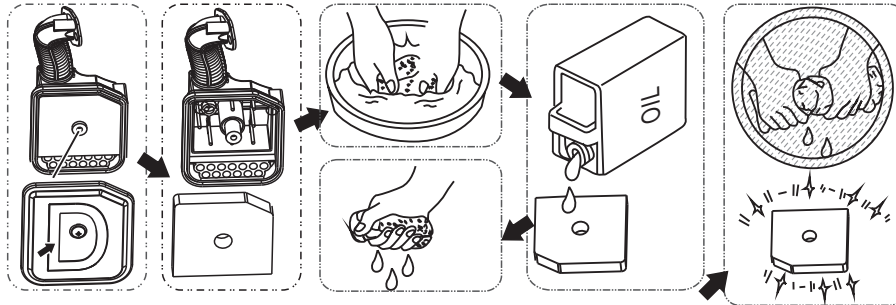
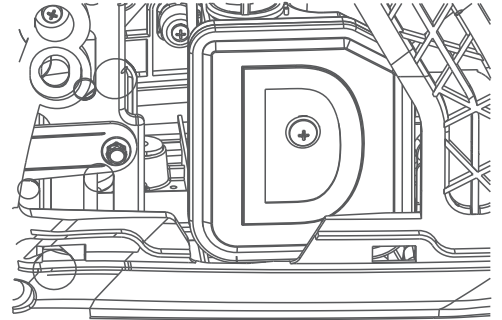

CAUTION!

Do not run the generator without reinstalling the foam element or excessive piston and cylinder wear may result.

Checking Muffler and Spark Arrester

- Inspect muffler for cracks, corrosion, or other damage.
- Remove screws, then remove the muffler cover as shown.
- Loosen bolt, then remove muffler cap, muffler screen, and spark arrester.
- Check the muffler screen and spark arrester for carbon deposits. Remove carbon deposits with a wire brush.
- Check the muffler screen and spark arrester for damage. If damaged replace with PULSAR replacement parts specifically designed for this unit.
- Install the spark arrester. Align the spark arrester projection with the hole in the muffler pipe.
- Install the muffler screen and muffler cap.
- Install the outer casing and tighten the screws.

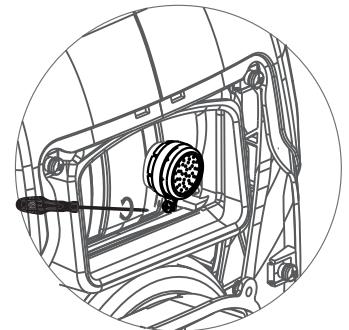
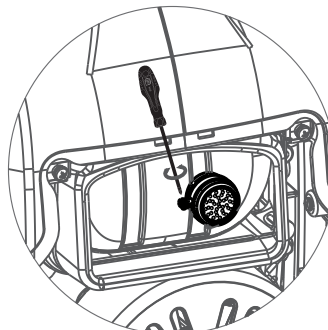
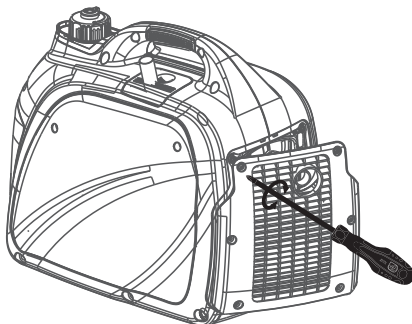

WARNING!



Avoid contacting hot areas of this unit.

- Use caution around the muffler, cylinder, and other engine parts as they can be extremely hot.
- Allow hot components to cool before touching.

MAINTENANCE

Fuel Tank Filter

- To clean, remove fuel cap and filter.
- Clean filter with gasoline.
- Wipe the filter with a clean rag.
- Install filter.
- Install fuel cap.

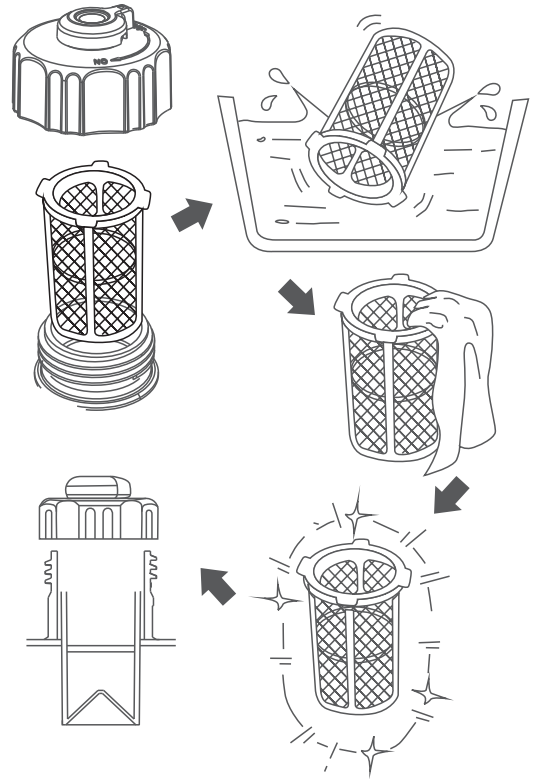

Fuel Filter

- To clean, remove screws, remove outer casing, and drain fuel.
- Lift and hold onto the clamp, then remove hose from tank.
- Take out fuel filter.
- Clean filter with gasoline.
- Wipe the filter with a clean rag and return filter to tank.
- Install hose and clamp.
- Open fuel valve. Inspect for leakage.
- Install outer casing and tighten screws.

Storage and Transportation of the Generator:

When transporting the generator, please keep the fuel cap on "OFF" to storage.

- Remove any debris that has collected on the generator and around the muffler and control panel. Use a brush or vacuum to remove loose dirt.
- Inspect air cooling slots. Remove any debris if obstructed.
- For short-term storage, start the generator once every 7 days.
- For semi-long term storage, add fuel stabilizer to prevent stale fuel from causing acid and gum deposits in the fuel system and carburetor.
- For long-term storage, drain the fuel.
- Store indoors to prevent freezing and use a protective cover to protect from dust.
- The generator must be Shipped, Run, and Stored in the upright position as seen in this image.

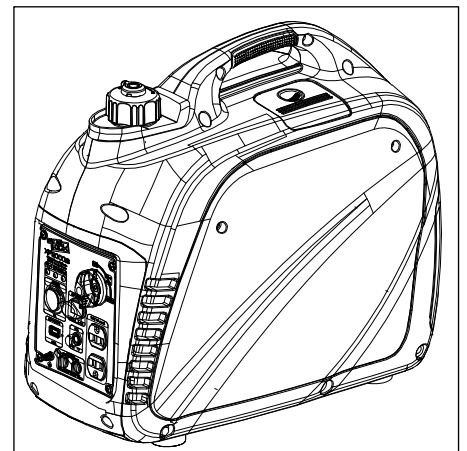

MAINTENANCE



WARNING!

Contact with a hot engine or exhaust system can cause serious burns or fires. Let the engine cool before transporting or storing the generator.



CAUTION!

Take care not to drop or strike the generator when transporting. Do not place heavy objects on the generator.

Engine Long Term Storage:

- Remove the spark plug and pour about 1 teaspoon of 10W30 Engine oil into the spark plug hole. Reinstall the spark plug. With the 3 in 1 switch in the “OFF” position pull the recoil starter cord several time to coat the cylinder walls with oil.
- Slowly pull the recoil starter until you feel the engine build compression (when you feel resistance). Leave the engine in this state as this will prevent any corrosion on the cylinder walls if stored for a long period of time.

How to drain fuel

- Turn off the engine.
- Remove fuel cap and fuel tank filter.
- Use a siphon to transfer gasoline from generator into a gasoline approved container. Wipe up any spilled fuel with a clean rag.
- Start generator engine and let it run until it stops and all remaining fuel is consumed. Do not connect electronic devices to generator during this process.
- Remove outer casing screws, then remove outer casing.
- Drain fuel from carburetor by loosening the drain screw on the carburetor float chamber
- Turn the 3 in 1 switch to “LPG” position.
- Tighten the drain screw.
- Install the outer casing and tighten screws.
- When the engine has completely cooled down, turn the Fuel Cap Air Vent to the “OFF” position.

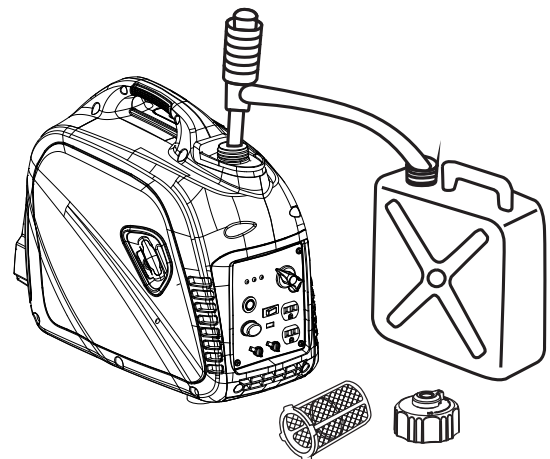
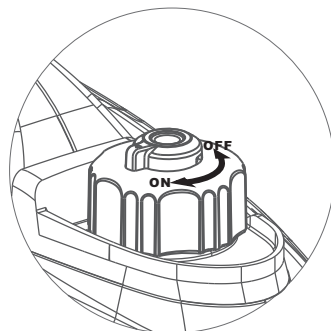
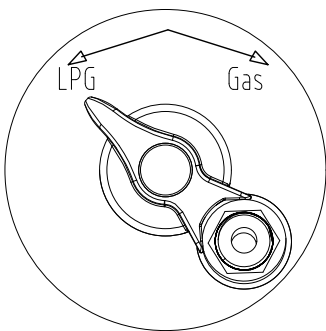

TROUBLESHOOTING

| Problem | Cause | Solution |
|--|--|--|
| Generator is running, but does not supply power. | <ol style="list-style-type: none"> 1. DC Circuit Breaker is "OFF" 2. Green AC Pilot Light Indicator is off. 3. Poor connection 4. Defective cord set 5. Connected device is faulty 6. Fault in generator | <ol style="list-style-type: none"> 1. Turn DC Circuit Breaker "ON" 2. Stop engine and restart. 3. Check and repair 4. Check and repair 5. Connect a device that is working properly 6. Contact service department |
| Engine runs good without load but bogs down when loads are connected | <ol style="list-style-type: none"> 1. Short circuit in connected device 2. Generator is overloaded 3. Clogged fuel filter 4. Engine speed is too slow 5. Short circuit in generator | <ol style="list-style-type: none"> 1. Disconnect device 2. See pg 17 "Don't overload generator" 3. Clean or replace fuel filter 4. Contact service department 5. Contact service department |
| <p>Engine will not start, shuts down during operation, or starts and runs rough.</p> <p>2. Clean or replace Air filter 3. Clean or replace fuel filter</p> | <ol style="list-style-type: none"> 1. Check battery connection properly 2. Dirty Air filter 3. Clogged fuel filter 4. Out of fuel or Stale fuel 5. Spark plug wire disconnected from spark plug 6. Bad spark plug 7. Water in fuel 8. Overchocking 9. Low oil level 10. Engine has flooded 11. Please try to recoil starter to starting. 12. Faulty ignition | <ol style="list-style-type: none"> 1. Make sure battery wire connection properly. 2. Clean or replace Air filter 3. Clean or replace fuel filter 4. Replace fuel 5. Reconnect spark plug wire 6. Clean or replace spark plug 7. Drain fuel tank and replace fuel 8. Turn off choke 9. Add oil level. 10. Wait 5 minutes and re crank engine 11. Please try a few times more. 12. Contact PULSAR dealer |
| Engine lacks power | <ol style="list-style-type: none"> 1. Generator is overloaded 2. Clogged fuel filter 3. Dirty Air filter 4. Engine needs servicing | <ol style="list-style-type: none"> 1. See pg 17 "Don't overload generator" 2. Clean or replace fuel filter 3. Replace Air filter 4. Contact service department |
| Engine "hunts" or falters | <ol style="list-style-type: none"> 1. Choke was removed too soon 2. Clogged fuel filter 3. Carburetor is running too rich or too lean | <ol style="list-style-type: none"> 1. Move to choke until engine runs evenly 2. Clean or replace fuel filter 3. Contact service department |

DIAGRAMS

| Model No. | | PG2200Bi | PG2200BiS |
|---------------|---|--|-----------|
| Generator | Type | Inverter | |
| | Rated Frequency | 60Hz | |
| | Rated Voltage | 120V | |
| | Maximum Output Power | 2.2kW | |
| | Rated Output Power | 1.8kW | |
| | Power Factor | 1.0 | |
| | AC Output Quality | ISO8528 G1 | |
| | THD% | ≤3% | |
| | DC Output | 12V/8A | |
| | Overload Protect | DC | Yes |
| AC | | Yes | |
| Engine | Engine Type | Single Cylinder, 4-Stroke, Forced Air Cooling, OHV | |
| | Displacement | 80cc | |
| | Fuel Type | Unleaded Gasoline | |
| | Fuel Tank Capacity | 4.5L / 1.18gal. | |
| | Continued Running Time (At Rated Power) | 4hours | |
| | Engine Oil Capacity | 350ml / 11.8oz | |
| | Spark Plug Model No. | E6TC/E6RTC / BPR6HS | |
| | Starter Type | Recoil Starter | |
| Generator Set | Length Width Height | 560x285x455 | |
| Net Weight | | 47.1lbs / 21kg | |

Pulsar Products continually seeks advancement in quality and product desing. Therefore, while this manual contains the most current product information available at the time of printing, there may be minor discrepancies between your product and this manual. If there is any question concerning this manual, please consult a PULSAR dealer. This manual should be considered a permanent part of this product and should remain with this product when resold. Products and specifications are subject to change without notice.

WIRING DIAGRAM

120V without Parallel Receptacle

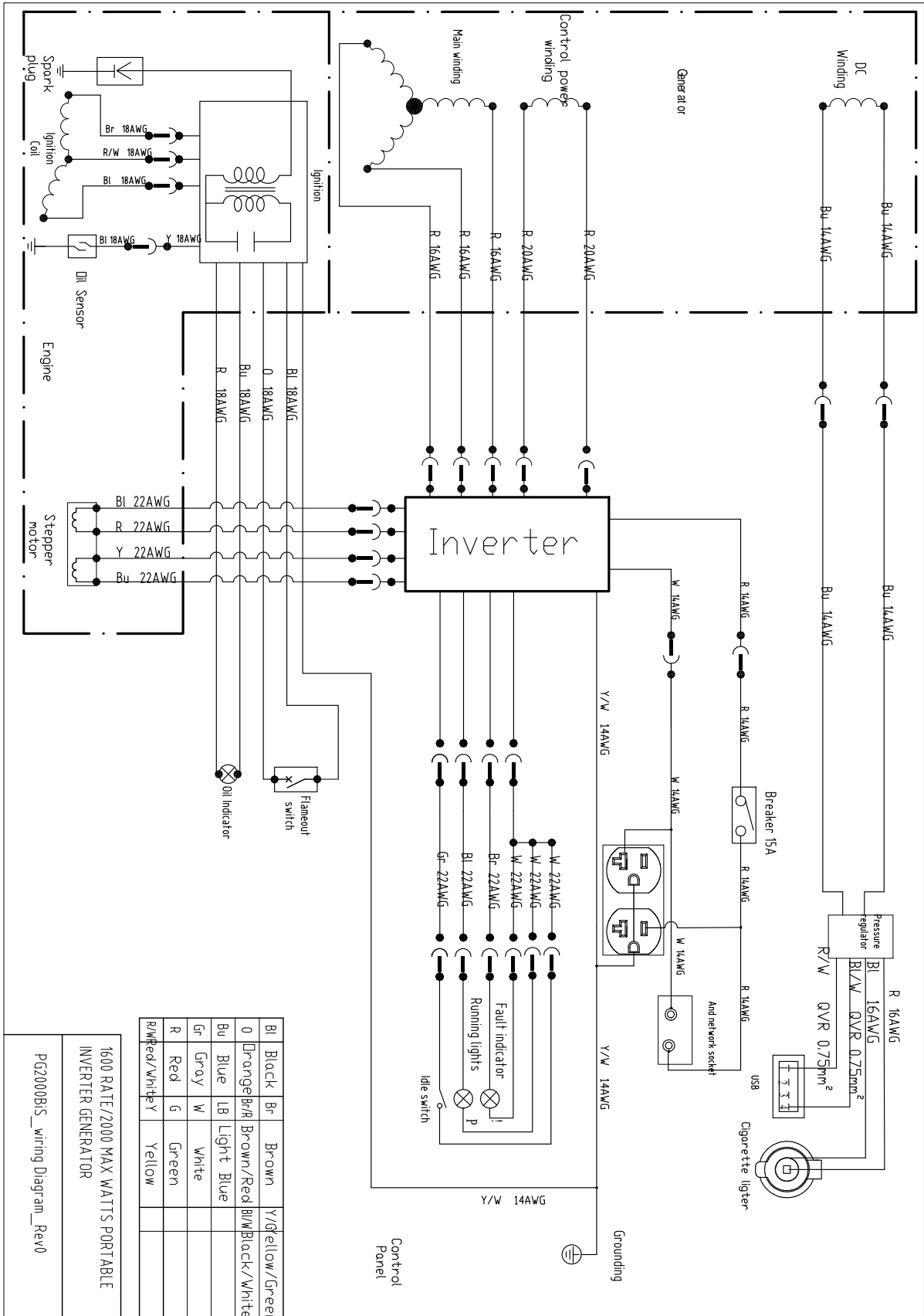

WARRANTY

Limited 1 Year Warranty:

From the date of original purchase, The warrants to the original purchaser, that each portable generator sold, shall be free from defect in material and workmanship, for the items and time period set forth below. It at its discretion, agrees to repair or replace any defective part that upon examination, inspection, and testing by a authorized service dealer, is found to be defective within the original warranty period. We will also decide upon the use of new or rebuilt parts or comparable product. Any part or product that is replaced, will be retained by us. This warranty period shall not be extended and any repaired product shall be warranted for the remaining period of the original warranty. The consumer is responsible, and shall prepay all transportation costs, including returning items to the factory or warehouse. This warranty is not transferable and proof of purchase must be presented for requesting warranty service. If proof-of-purchase or a receipt is not provided, the product's shipping date by the manufacture will be used to determine the warranty period.

Length of Warranty:

Personal use applications of this portable generator are warranted for one (1) year. Proof of purchase and of maintenance must be provided.

- Year 1 - Limited comprehensive coverage on all generator components and labor

“Personal use” means personal residential household use or recreational use by the retail consumer. “Commercial use” means all other uses including commercial, construction, or other income producing purposes. Once a generator has been used for commercial purposes, it shall thereafter be considered as a “commercial use” generator for the purposes of this warranty. Any portable generator used for commercial use, as rental equipment or for the purpose of primary power in place of utility will not be covered under this warranty.

Consumer Responsibilities:

- Consumer is responsible for carefully reading and following all instructions in the owner's manual. Any product that is damaged due to misuse or abuse will not be covered by this warranty.
- Consumer is responsible for all transportation costs to an authorized Service Center. Unless otherwise requested, ground shipping will be applied for part shipment and customer will pay any additional charges for expedited shipments.
- Consumer is responsible for labor costs associated with warranted repairs twelve (12) months after the purchase date. Labor rates will only be based on normal working hours.
- Consumer is responsible for maintaining generator as specified in the owner's manual. Documentation of this maintenance may be required to cover warranty requests.
- Consumer is responsible for presenting any problems with the generator to an authorized PULSAR Service Center as soon as the problem exists. Warranted repairs will be completed in a reasonable period of time, not to exceed 30 days.

WARRANTY

What this Warranty Does Not Cover:

- **Normal wear:** This warranty excludes normal wear items such as filters, spark plugs, gaskets, O-rings, adapter cord sets, wheels, and starting batteries.
- **Maintenance:** This warranty does not apply to tune-ups or routine maintenance and does not cover any adjustments or repairs not performed by an authorized repair facility.
- **Misuse:** This warranty does not apply if your product has failed due to abuse, misuse, neglect, using incorrect fuels or lubricants, overloading, over-speeding, improper maintenance, improper storage, unapproved modifications, or has been operated in any way contrary to the instructions found in the products owner's manual.
- **Adverse conditions:** This warranty does not apply if your product has failed due to freezing, accident, natural disasters.
- **Product Shipment:** This warranty does not apply to damage resulting from shipping, handling, or warehousing: Any damage claims to this product caused by shipment must be filed with freighter.
- **Other exclusions:** This warranty does not apply if your product has been sold "as is" or where the factory applied serial number has been removed. Refurbished, used, demonstration or floor models are not covered by this warranty.

Where Warranty is Valid:

For warranty coverage, this product must be purchased from an authorized PULSAR dealer and the warranty only extends to the original purchaser in the United States, Canada, or Mexico. Refurbished used, demonstration, or floor models are not covered by this warranty. Products purchased from on-line auction websites, such as ebay, are not covered under this warranty. Products used for commercial use are not covered under this warranty.

How to Obtain Warranty Service:

Take the original receipt and product to the place of purchase or mail the original receipt and product to the address found on the web site if purchased on-line. PULSAR recommends you retain all of your receipts covering the purchase and maintenance of your Portable Generator, but will not deny you warranty coverage as long as proof of purchase or service can be obtained.

PULSAR'S OBLIGATION UNDER THIS WARRANTY IS EXCLUSIVELY LIMITED TO PRODUCT REPAIR OR REPLACEMENT AND SHALL NOT BE LIABLE FOR ANY INCIDENTAL OR CONSEQUENTIAL DAMAGES INCLUDING, BUT NOT LIMITED TO, THE EXPENSE OF DELIVERING PRODUCT TO AND FROM REPAIR CENTER, LOSS OR DAMAGE TO PERSONAL PROPERTY, LOSS OF REVENUE, TELEPHONE CHARGES, LOSS OF TIME, OR INCONVENIENCE. SOME STATES, PROVINCES, OR JURISDICTIONS DO NOT ALLOW THE EXCLUSION OR LIMITATION OF INCIDENTAL DAMAGES, SO THE ABOVE LIMITATION MAY NOT APPLY TO YOU. THIS WARRANTY GIVES YOU SPECIFIC LEGAL RIGHTS, AND YOU MAY ALSO HAVE OTHER RIGHTS WHICH VARY FROM STATE TO STATE OR PROVINCE TO PROVINCE.

