

270 Awning Plus Fitting Guide

1. Welcome to the Naturnest 270 Awning plus fitting guide! We're thrilled that you've chosen our product to enhance your camping experience. To ensure you enjoy the full benefits of this awning, it's essential to install it correctly. In this comprehensive guide, we'll walk you through each step of the fitting process, and share some expert tips and tricks to help you maximize your awning's performance. So, let's dive in and get your Naturnest 270 Awning set up for your next adventure!



2. To ensure a smooth installation of your Outback Tourer 270 Awning, it's crucial to gather all the essential tools and equipment beforehand. Start by unpacking your awning and locating the fitting hardware which is stored in a practical grey canvas bag provided in the box. This hardware bag contains everything you need to securely install your awning, including two mounting brackets. You'll also find sturdy ground pegs to keep your awning steady on firm surfaces like grass or dirt (though not recommended for beach use), ropes to anchor your awning, and a bag of nuts and bolts for installation purposes.
3. Assembling the brackets is just the first step - the real fun begins when it's time to bolt them onto your car. Finding the perfect spot on your roof racks or platform is key, but don't forget to follow our guidelines to ensure maximum strength of the awning frame. If you're also installing one of our Roof Top Tents, take some time to figure out how far the brackets need to overhang the sides of the car to accommodate your tent.
4. With the brackets in place, it's time to bolt them down. We recommend using a little bit of anti-seize on the bolts to avoid binding up - they're stainless steel, after all! Depending on your setup, you can either drill holes and bolt the bracket through

the centre of the rail or use U bolts to clamp around the cross bar. If you're bolting to a platform, check with your supplier to find the right bolts that will slide in easily.

Once the brackets are securely fastened, it's time to attach the awning itself. Lift the awning with a friend and align the bolts with the bracket holes. Loosely fasten the nuts, then adjust the awning's position as needed. When tightening the nuts, be sure to do so snugly, but without overdoing it. And don't forget to use anti-seize for those stainless bolts!

Now that everything is in place, it's time to hit the road with your brand-new awning. Ready to take on whatever adventures come your way!

Mounts directly on the cross bar

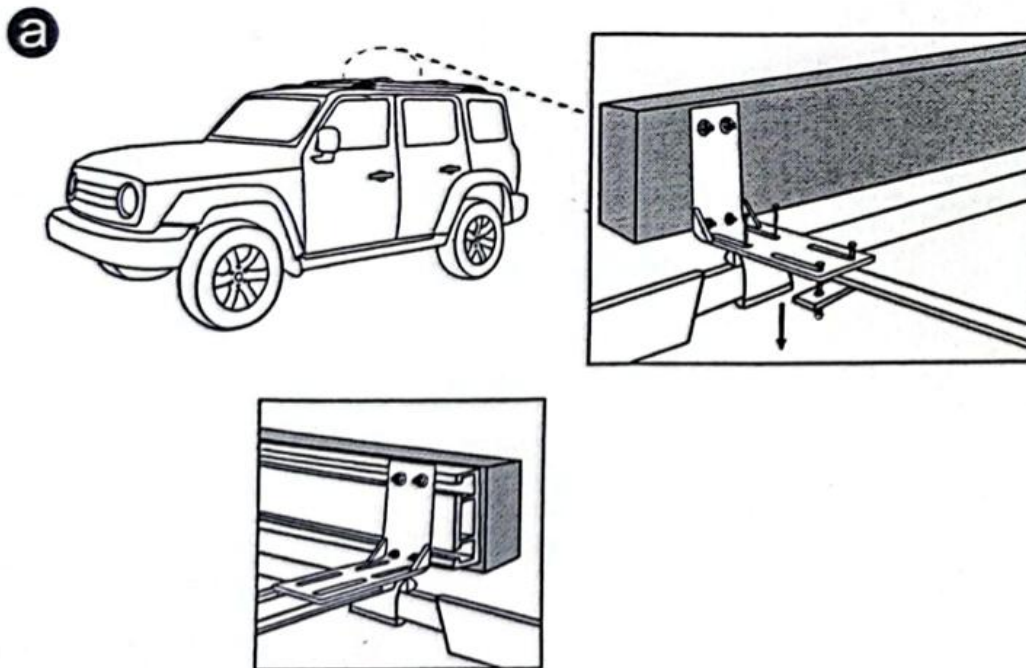

Mounts directly on the roof wishbone

a

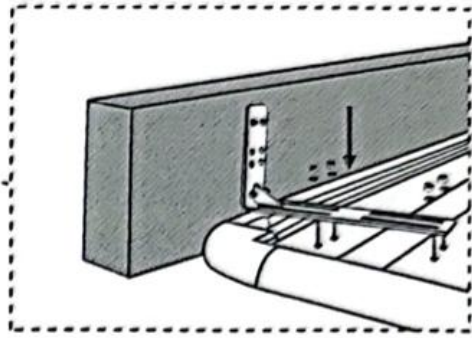
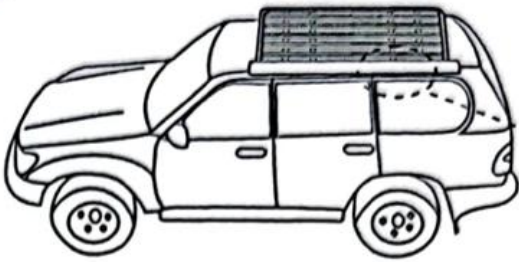

b

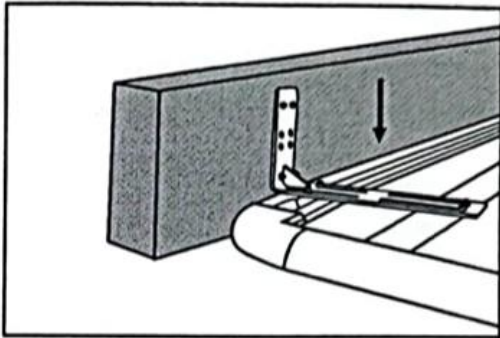

Mounts directly on the luggage rack

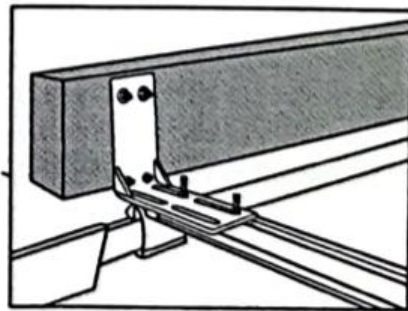
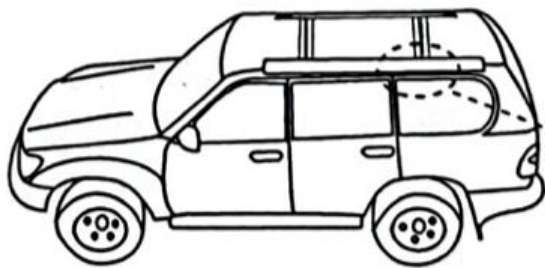

a

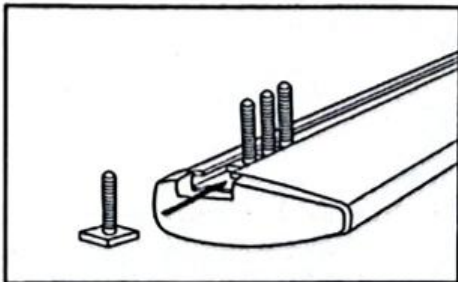

b

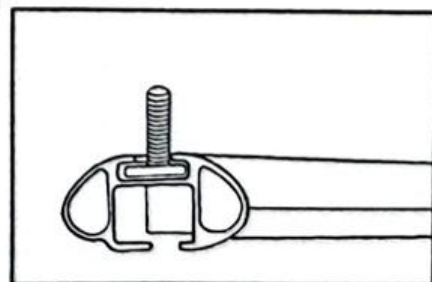

Setup/Pack Up

To set up the awning:

1. To begin, simply unzip the bag and fold it around the back of the frame to keep it out of the way.
2. Next, grab the strap on the first arm and walk it around towards the back of your car. Take the strap on the other wrist and loop it around the front of the car. Find a suitable location to hook that strap onto and tighten it.
3. Once tightened, your awning is free-standing and ready to go! If the weather worsens and you want to secure the awning further, simply undo the Velcro around the legs and drop them to the ground. Adjust the height as desired, twist the two halves of the legs to tighten them, and grab the supplied guy ropes. Tie the guy ropes through the eyelets on the awning and use the supplied pegs to secure them to the ground. Finally, tighten the guy ropes. We always recommend using common sense and securing your awning if you plan to remain stationary for an extended period.

To pack up the awning:

1. To pack up the awning, repeat the above process in reverse. Ensure that all rain arms are folded away, and legs are secured back up into their original position.
2. Undo the strap that secures the awning and walk it around to the front of the car. Reach up and ensure that the buckles in the bag are free and ready to be strapped in.
3. You will be left with the canvas hanging down in the shape of half a triangle. Simply fold this in half and then roll it up nice and snug.
4. Finally, grab the three Velcro straps and secure the awning in place, ensuring that it is nice and secure to avoid damage during transit. Fold the bag back over and zip it up.



Tips & Tricks

1. Prior to packing up the awning, it is essential to ensure that it is clean and completely dry. If the awning has been packed up while still damp, it is imperative to air it out as soon as possible to prevent any potential damage.
2. Make sure to fold down the rain arms to avoid any obstructions when packing up the awning.
3. It is crucial to check that nothing is caught or tightened up in the awning structure before packing up, as this could result in damage during transport.
4. Properly securing the awning for transport is essential to avoid any harm during transit.
5. While the awnings are free-standing, it is still advisable to tie them down with ropes if you plan to stay in one place for an extended period, as unexpected gusts of wind could cause damage.
6. In the event of heavy rainfall, it is vital to raise the rain arms and tie down the awning between them to create a rain gutter. The ground nails and the awning need to be linked through wind ropes so that the surface of the awning forms a downward slope to avoid water accumulation. This will prevent water from pooling on top of the awning and potentially causing structural damage.



7. To ensure longevity and prevent rusting, it is recommended to apply lanolin spray to the bolts every two months.