

Caution: Please read the entire manual before proceeding
View warranty and disclaimer on page 13

Getting Started

Before we start lets make sure we have the correct mount and all the required tools and hardware to complete the installation.

- ✓ The TV is a Flat Panel TV between 13" - 37" and weighs no more than 40lbs.
- ✓ The Wall the TV will be mounted on is either concrete or dry wall with wood studs.
- ✓ You have all of the following tools:



Check out our free level app in the app store!

If you answer "Yes" to all the questions above then you are ready to begin the TV Mount installation!

2

Step 2 : Attach Mounting Bracket to TV

- 1 Check what screw size will fit in your TV. (**M-A, M-B, M-C, M-D**)

Note: If Your TV has a curved back you may need to use longer screws with spacers (**M-F**).

- 2 Align the mounting bracket onto the back of the TV and install with the appropriate hardware and tighten.

Note: If the back of your TV is curved, use the appropriate Combination of spacers to level the mounting brackets.

Tool Required:



5



Caution: Hand tighten with screwdriver only, over tightening may damage the TV!
Do not use an electric drill for this step!

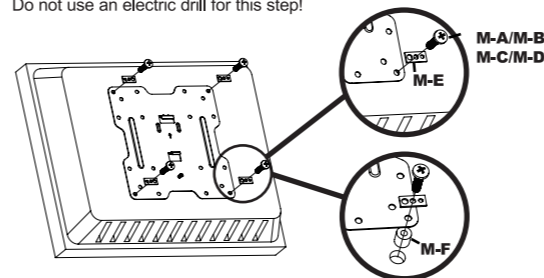

Step 3B : Install Wall Plate on Concrete

- 1 Level the wall plate and make 3 marks with pencil to show where to drill the pilot holes.
- 2 Remove the wall plate and drill the pilot holes with a 3/8" drill.

Tools Required:

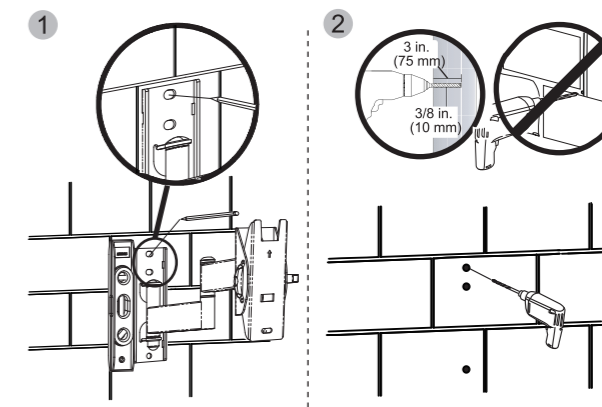
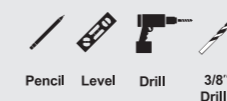

Caution: The minimum depth of the concrete must be 8". Do not drill pilot holes into the mortar between the concrete.

8

Caution: This product contains small items that could be a choking hazard if swallowed.

Parts & Hardware

Caution: Before starting assembly, verify all parts are included and undamaged. If any parts are missing or damaged, do not return the damaged item to your dealer; contact Customer Service. Never use damaged parts or previously used parts!

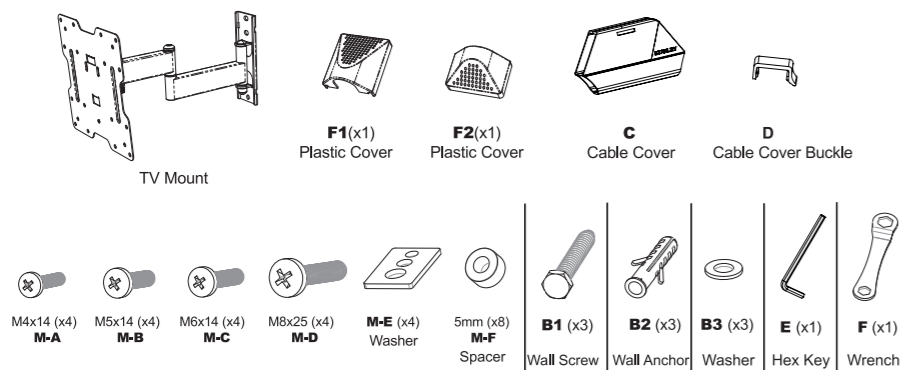

For attaching TV to Mount

3

Step 3A : Install Wall Plate on Drywall with Wood Stud Note : For Concrete skip to Step 3B

- 1 Use the stud finder to locate 1 stud. Then draw a vertical line marking the center of the stud.
- 2 Level the wall plate and align it with the center of the studs. Make 3 Pencil marks to indicate where to drill.

Tools Required:

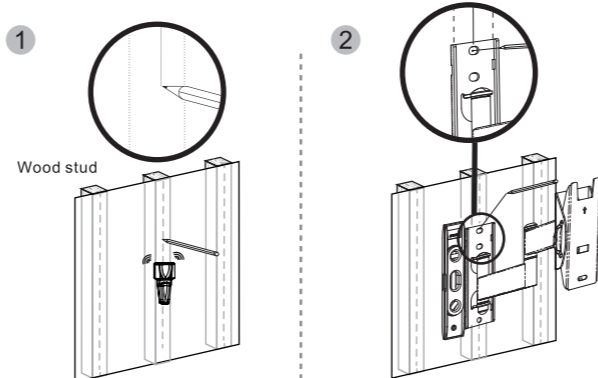

Caution: The minimum size of the woodstud must be 2"x 4" and the thickness of the drywall must not exceed 5/8".

6

- 3 Insert the anchors into the 3 pilot holes. Tap with Hammer.
- 4 Align wall plate with pilot holes and anchors. Insert 3 bolts through washers and anchors then tighten with wrench.

Tools Required:

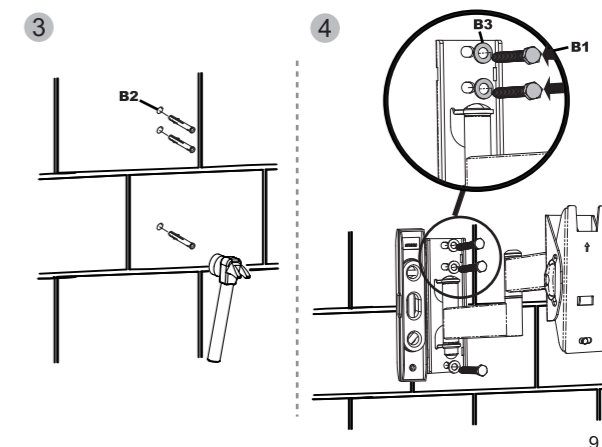

9

Step 1: Preparation

- 1 Loosen nut securing vesa plate. Remove nut and washers.
- 2 Remove vesa plate.

Tools Required:

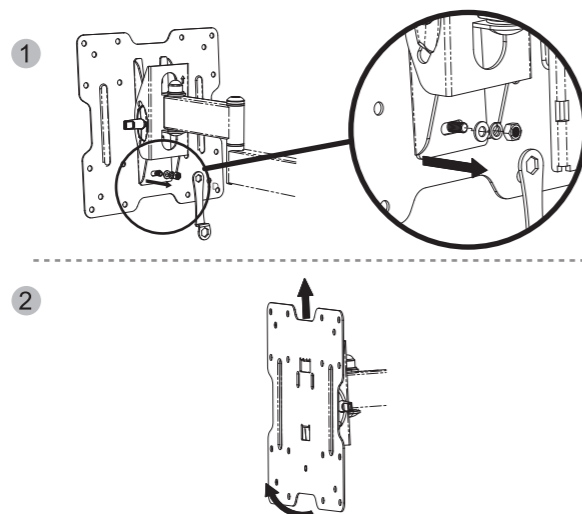

4

- 3 Remove the wall plate and drill the pilot holes with a 3/16" drill.
- 4 Align the wall plate with the pilot holes and insert 3 bolts through the washer in the pilot holes and tighten.

Note: use bubble level to level the mount before fully tightening all screws.

Tools Required:

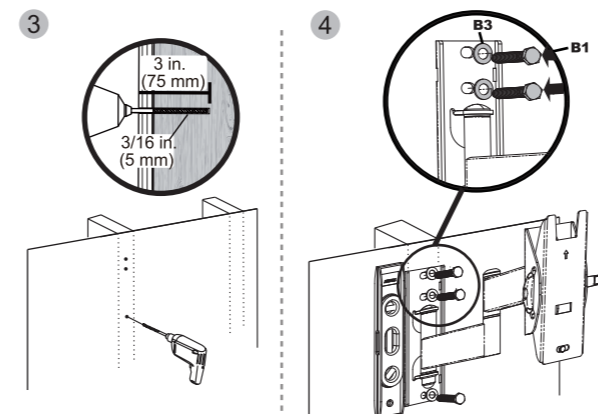

7

Step 4: Hang Your TV

- 1 Lift the TV and secure it with the hook on the top bracket, Always have two people lift TV.
- 2 Install back the screw nut and the washer dismantled in step 1, tighten.

Tools Required:

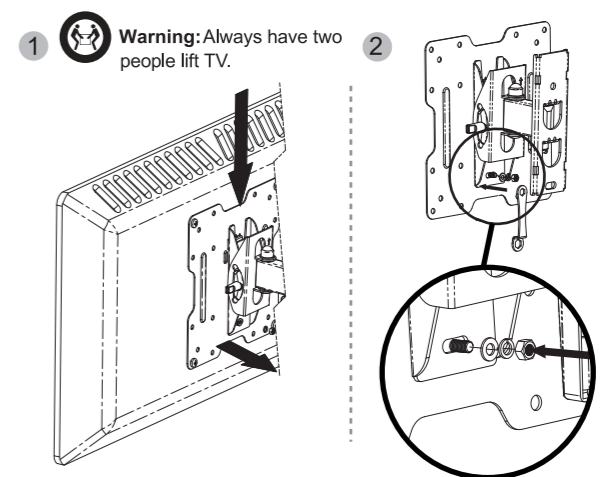

10