

General Disclaimer

Disclaimer – Suncraft Solutions Inc. has extended every effort to ensure accuracy and completeness of this manual. However, Suncraft Solutions Inc. does not claim that the information covers all installation, situational or operational variables. The information contained in this document is subject to change without notice or obligation of notification of any kind. Regarding the information contained herein, Suncraft Solutions Inc. makes no representation of warranty, expressed or implied, and assumes no responsibility for accuracy, sufficiency, or completeness of the information contained in this document.

WARNING: FAILURE TO READ, THOROUGHLY UNDERSTAND, AND FOLLOW ALL INSTRUCTIONS CAN RESULT IN SERIOUS PERSONAL INJURY, DAMAGE TO PERSONAL PROPERTY, OR VOIDING OF LIMITED WARRANTY!

It is the responsibility of the installer of this product to ensure all components are properly assembled and installed using the instructions provided. If you do not understand these instructions or have any questions or concerns, please contact customer service at 1-855-816-6868 or service@suncraftsolutions.com. Do not attempt to install or assemble this product if the product or hardware

is damaged or missing. In the event that replacement parts or hardware are needed, please contact Customer Service at 1-855-816-6868 or service@suncraftsolutions.com. International customers needing assistance should contact the Dealer from which they purchased the product.

The included hardware is designed for use on vertical walls constructed of wood studs or solid concrete. A wood stud wall is defined as consisting of a minimum of 2x4 wooden studs (1.5" wide by 3.5" deep 51 x 102 mm) with a maximum of 5/8" (16 mm) drywall. The included hardware is not designed for use with metal studs or cinderblock walls. If you are uncertain or knowledgeable about the construction of your wall, then please consult a qualified contractor or professional installer for assistance. The wall you are mounting to must support 4 times the weight of the total load. The load is defined as the TV and Mount along with anything else suspended from the mount. If not, then the surface must be reinforced to meet this standard. The installer is responsible for verifying that the wall structure and hardware used in any installation method will safely support the total load.

STANLEY®

TV Mount Installation Guide

Thank you for choosing Stanley – the hardware of choice for Architects, Contractors, and Home Owners for its quality, performance and dependability.

Enclosed are your step-by-step instructions for an install made easy.



If you get stuck, give customer service a call at 1-855-816-6868
You can also reach us at contact@stanleymounts.com

Caution: Please read the entire manual before proceeding
View warranty and disclaimer on page 10

Getting Started

Before we start lets make sure we have the correct mount and all the required tools and hardware to complete the installation.

- ✓ The TV is a Flat Panel TV between 32" - 70" and weighs no more than 80lbs.
- ✓ The Wall the TV will be mounted on is either concrete or dry wall with wood studs.
- ✓ You have all of the following tools:



Check out our free level app in the app store!

If you answer "Yes" to all the questions above then you are ready to begin the TV Mount installation!

2

Step 2A: Install Wall Plate on Drywall with Wood Stud

Note: For Concrete skip to Step 2B

- Use the stud finder to locate 2 studs. Then draw a vertical line marking the center of the stud.
- Level the wall plate and align it with the center of the studs. Make 4 Pencil marks to indicate where to drill.

Tools Required:



5

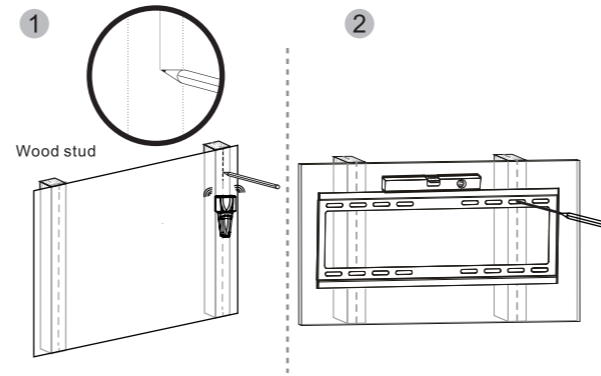

Caution: The minimum size of the woodstud must be 2"x 4" and the thickness of the drywall must not exceed 5/8".

- Insert the anchors into the 4 pilot holes. Tap with a hammer.
- Align wall plate with pilot holes and anchors. Insert 4 bolts through washers and anchors then tighten with wrench.

Tools Required:



8

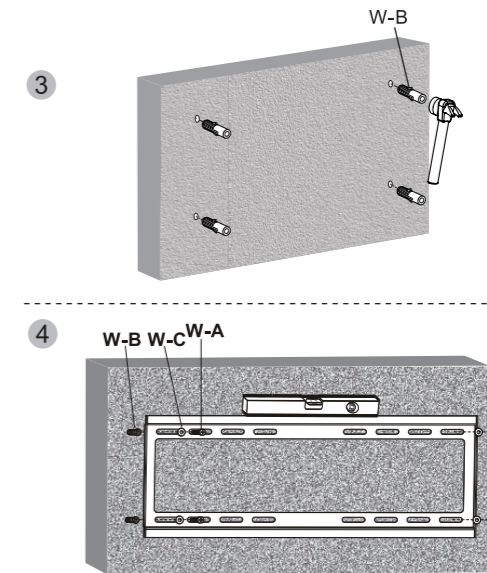

Step 3: Hang Your TV

Warning: Always have two people lift TV.

- Lift the TV and secure it with the hook on the top bracket. Always have two people lift TV.
- The two ropes pulled down, and Pull the TV to the wall, loosen the two ropes.

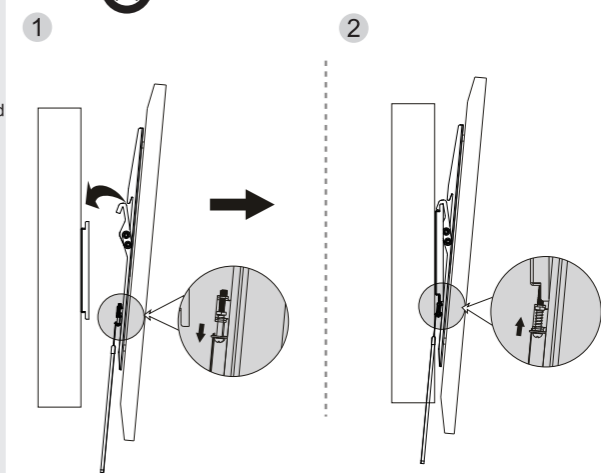

9

Caution: This product contains small items that could be a choking hazard if swallowed.

Parts & Hardware

Caution: Before starting assembly, verify all parts are included and undamaged. If any parts are missing or damaged, do not return the damaged item to your dealer; contact Customer Service. Never use damaged parts or previously used parts!

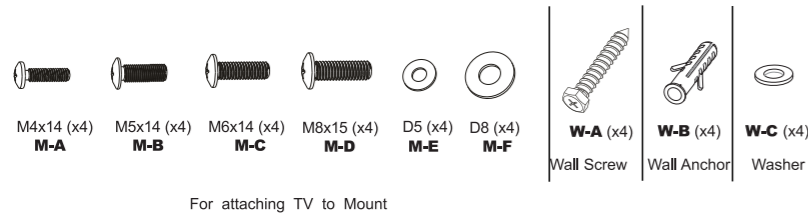
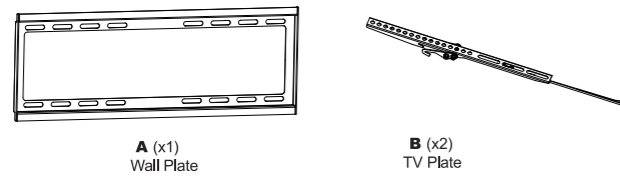

For attaching TV to Mount

3

- Remove the wall plate and drill the pilot holes with a 3/16" drill bit.
- Align the wall plate with the pilot holes and insert 4 bolts through the washer in the pilot holes and tighten.

Tools Required:



6

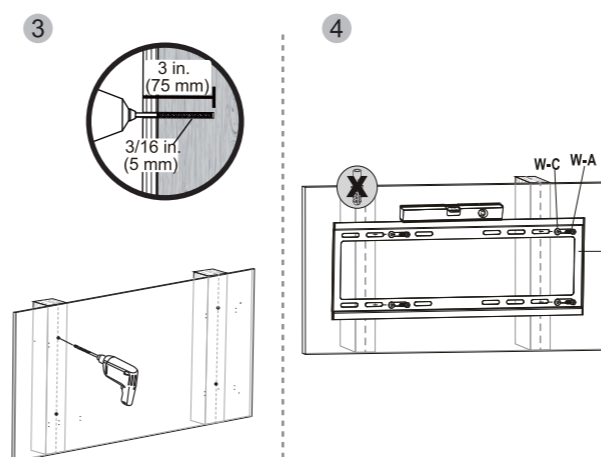

Step 1: Attach Mounting Bracket to TV

- Check what screw size will fit in your TV (M-A, M-B, M-C, M-D).
- Align the mounting bracket onto the back of the TV and install with the appropriate hardware and tighten.

Tools Required:



4



Caution: Hand tighten with screwdriver only, over tightening may damage the TV!
Do not use an electric drill for this step!

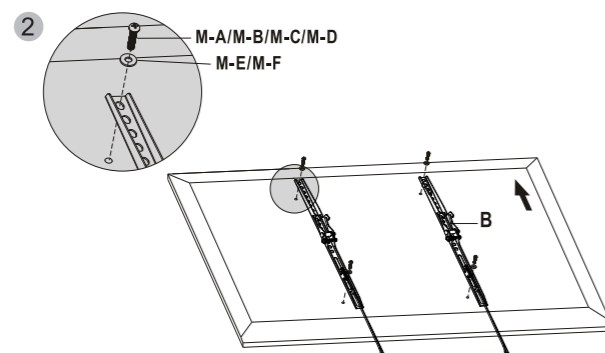

Step 2B: Install Wall Plate on Concrete

- Level the wall plate and make 4 marks with pencil to show where to drill the pilot holes.
- Remove the Wall plate and drill the pilot holes with a 3/8" drill bit.

Tools Required:

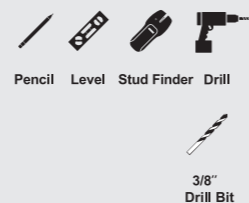

7

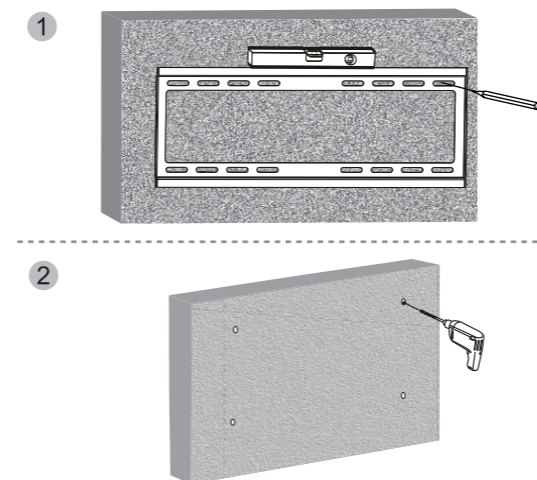

Caution: The minimum depth of the concrete must be 8". Do not drill pilot holes into the mortar between the concrete.

SUNCRAFT SOLUTIONS INC. LIMITED WARRANTY

SUNCRAFT SOLUTIONS INC. LIMITED WARRANTY

SUNCRAFT SOLUTIONS, INC. warrants its products to be free of defects in material and workmanship for the product's Warranty Period. The Warranty Period commences on the original purchase date of the product and the sales receipt serves as proof of purchase.

All SUNCRAFT SOLUTIONS, INC. products are covered by a limited product warranty of three (3) years for all metal mounts and fixtures and non electrical items.

This Limited Warranty extends only to the original purchaser and is non-transferable. It is automatically void if your SUNCRAFT SOLUTIONS, INC. product is modified or altered in anyway, improperly or incompletely installed, usage of non-supplied hardware and used in a non-conventional method, exceeding the weight capacity or size restrictions. All SUNCRAFT SOLUTIONS, INC. products are intended for indoors consumer or commercial use only and any outdoor or use in areas subject to weather and high humidity, water vapor or exposure to the elements use voids this Limited Warranty. The Limited Warranty for all mounts is void if the mount is transferred from one location to another. To the maximum extent permitted by applicable law, SUNCRAFT SOLUTIONS, INC. disclaims any other warranties,

express or implied, including warranties of fitness for a particular purpose and warranties of merchantability, SUNCRAFT SOLUTIONS, INC. will not be liable for any damages whatsoever arising out of the use or inability to use its products, even if SUNCRAFT SOLUTIONS, INC. has been advised of the possibility of such damages. To the maximum extent permitted by applicable law, SUNCRAFT SOLUTIONS, INC. disclaims any responsibility for incidental or consequential injuries, damages to persons, properties and other items.

For warranty claims made during the stated warranty period, SUNCRAFT SOLUTIONS, INC. will replace any defective product part free of charge. Contact SUNCRAFT SOLUTIONS, INC. at 1-855-816-8888 to make a warranty claim or e-mail warranty@suncraftsolutions.com. Proof of warranty is required. This Limited Warranty does not cover the costs of removing and replacing defective parts from your SUNCRAFT SOLUTIONS, INC. product. SUNCRAFT SOLUTIONS, INC. assumes no liability for any installation, adjustment or other costs.

10