



**IB BETAFENCE**

**Egidia Tempofor SC**

Sales book 2018

# Egidia Tempofor

1. Background
2. General characteristics
3. Technical characteristics
  - 3.1 Overview
  - 3.2 Dimensions
  - 3.3 Guiding post
  - 3.4 Lock post
  - 3.5 Wing
  - 3.6 Automatic execution
  - 3.7 Manual execution
4. Installation guidelines
5. Advantages for the end user/installer
6. Ordering data
7. Pictures

# 1. Background

The Tempofor® gate is CE certified cantilever sliding gate which has been designed and built to temporary control and secure access of construction sites, temporary facilities and events.

It is offered in manual or automatic execution. End post with an integrated catcher is installed in line with the gate. Guiding post and End post are foreseen with a fence connection.



## 2. General characteristics

- The Tempofor<sup>®</sup> gate is completely made out of galvanized steel with a free passage of up to **4.63m** and wing height **1,87m**
- The gate has a robust welded frame and features the Nylofor<sup>®</sup> 3D infill.
- Manual or automatic execution is mounted on a concrete base for direct placement on site. Gate also features left or right opening.
- The base is designed to be combined with the Tempofor panel range and allows smooth integration of the gate.
- The complete assembly, gate and concrete base, can easily be moved by forklift.
- Anchor points are foreseen in the concrete base for a steady fixation to the ground.
- Fence connections on the guiding and end posts for rigid installations fence + gate

## 3. Technical characteristics

### ■ 3.1 Overview

<b>Gate specifications</b>	
<b>Free passage</b>	4630mm
<b>Wing height</b>	1870 mm
<b>Total needed free space</b>	12250mm + 500mm to first obstacle
<b>Coating</b>	Hot dip galvanized
<b>Weight with concrete base</b>	844 kg
<b>Infill</b>	Nylofor 3D
<b>Wing</b>	Underbeam 75x65 Horizontal profiles 60x40 Vertical profiles 40x40
<b>Guiding post</b>	Single guiding post 120x80
<b>Lock post</b>	Double Lock post 80x80

# 3. Technical characteristics

## ■ 3.2 Dimensions

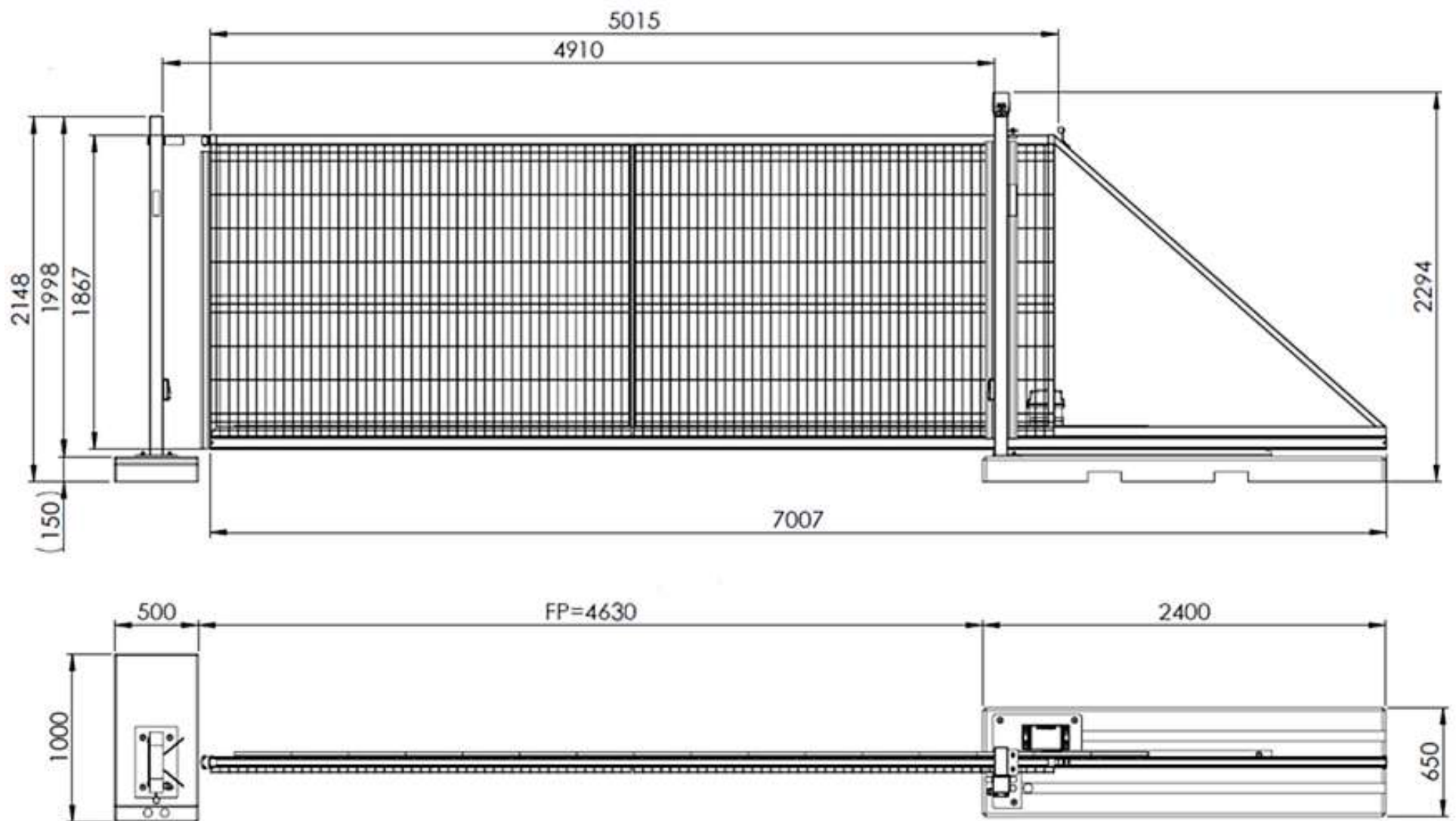

## 3. Technical characteristics

### 3.3 Guiding post

Single guiding post  
made of 120x80 profiles

Concrete base plate  
(prepared to be handled  
with forklift)

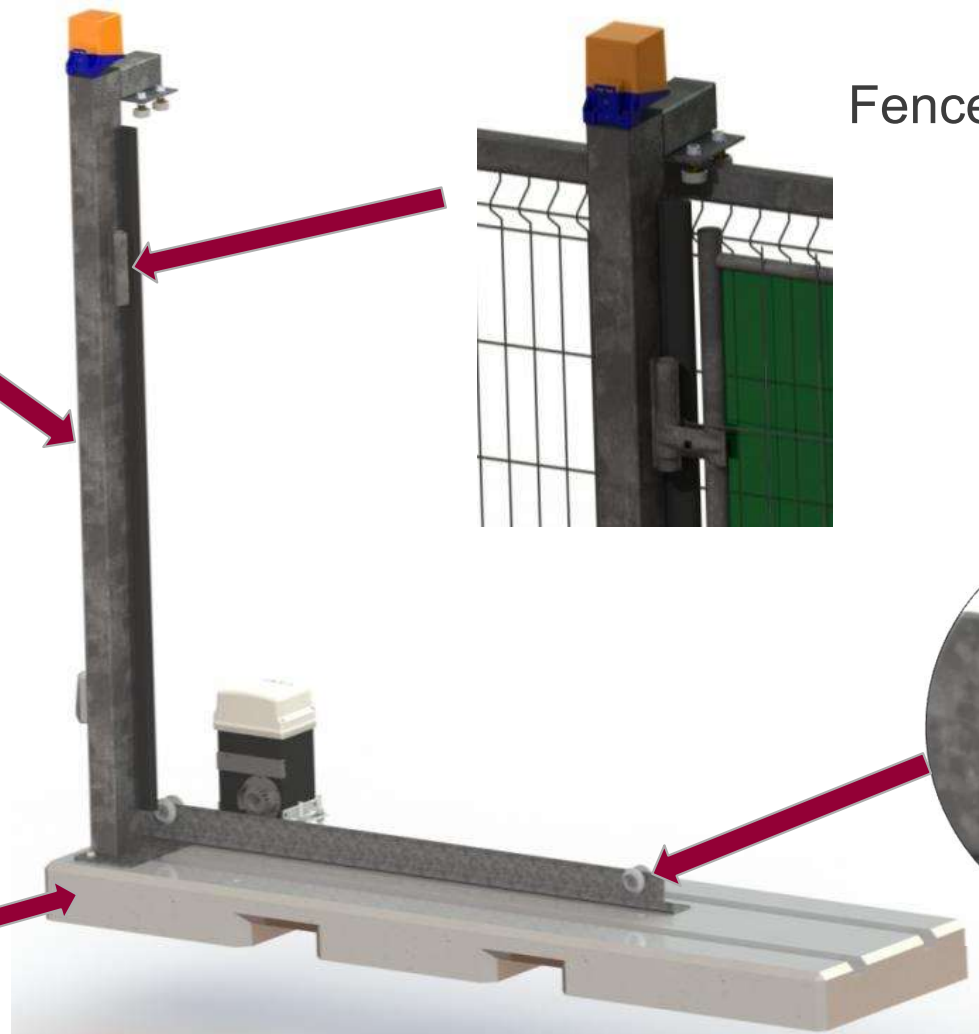

Fence connection

2 sets of guiding rollers  
made of polyamide

# 3. Technical characteristics

## ■ 3.4 Lock post

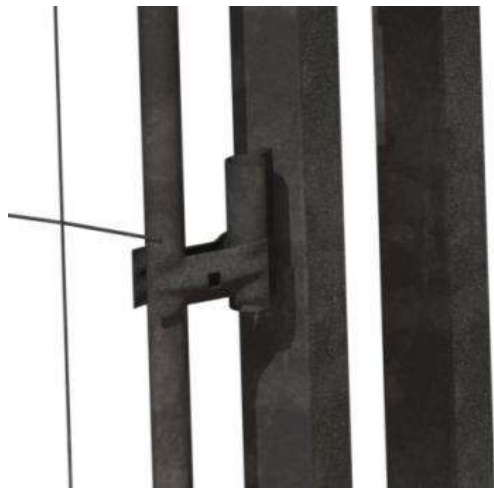

Fence connection

Double lock post made of 80x80 profiles

Concrete base plate (prepared to be handled with forklift)



Catcher



## 3. Technical characteristics

### ■ 3.5 Wing

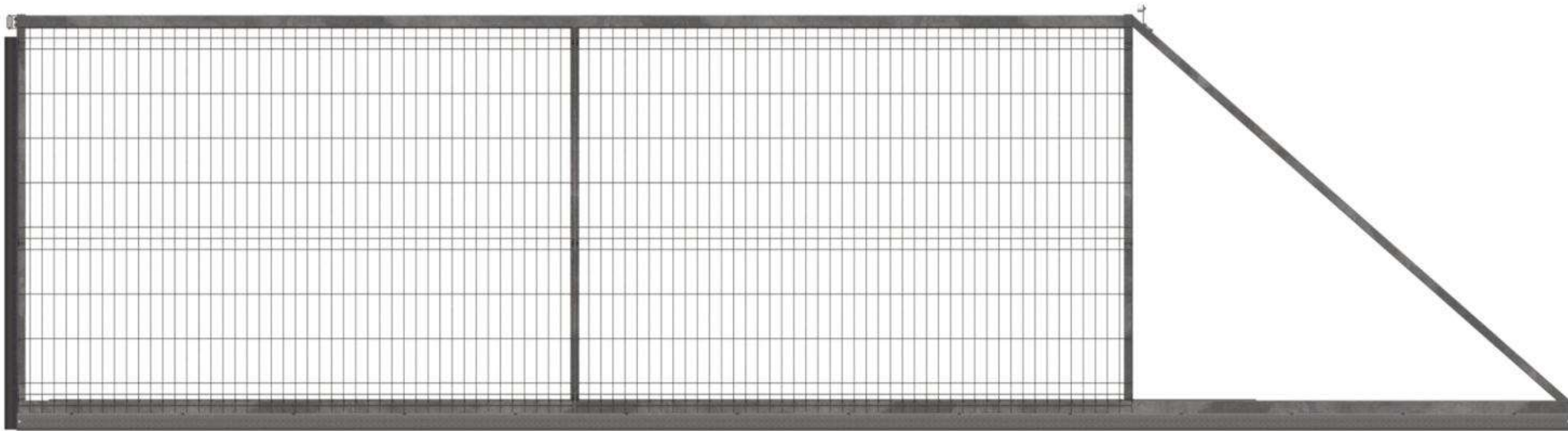

- Underbeam 75x65
- Frame 60x40 and 40x40
- Nylofor 3D infill
- Guiding rollers on front
- Stop bumper on back

## 3. Technical characteristics

### ■ 3.6 Automatic version

The Egidia Tempofor® SC gate is offered in automatic execution. It is designed and built to temporary control and secure access to construction sites, temporary facilities and events.



Motor FAAC 746



FAAC LED 230V



868MHz SLH Remote controller



XP20W Wireless  
Photocells with batteries

### 3. Technical characteristics

Type	Tempofor Automatic
Motor	FAAC 746 ER16
Controller Board	780D
Plug-in receiver	868MHz
Nr of remote controls	1
Photocells	XP20W
Nr. of photocells	1
Height of the photocells	600 mm
Warning Light	FAAC - LED light 230V (orange)
Safety edges	Active (ASO)
Nr./ Type of safety edges on GP	2 pc's ASO model SENTIR 65ST
Safety edges on front wing	ASO model SENTIR 65ST
Transmission system	JCM RADIOBAND

## 3. Technical characteristics

### Plug and play

The Egidia Tempofor® SC gate is fully assembled and tested. It is delivered in „Plug & play concept” with 3m power cable.



Remote controller is programmed and allows to start using the gate immediately after installation.

# 3. Technical characteristics- wiring diagram

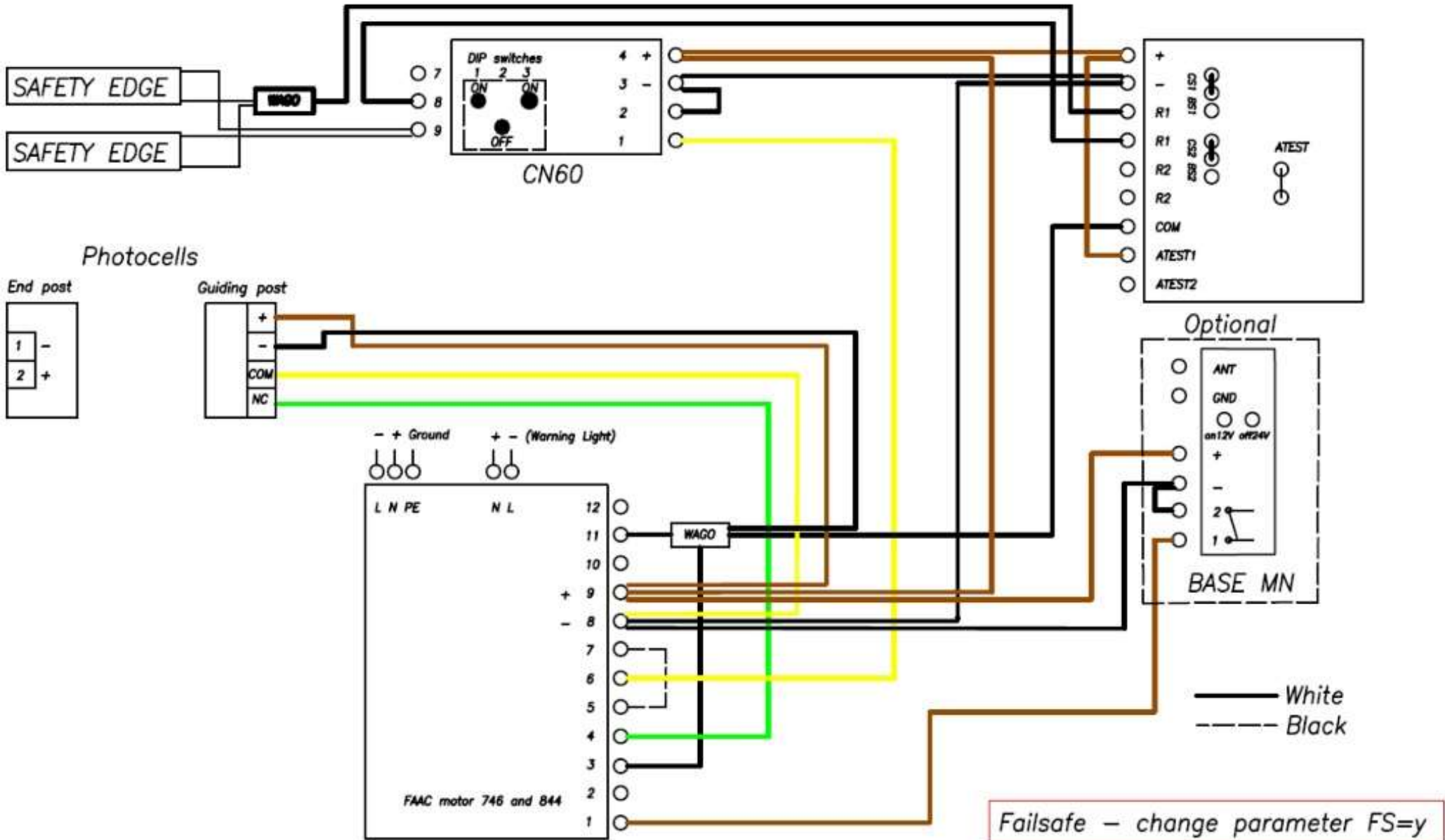

## 3. Technical characteristics

### ■ 3.7 Manual version

The Tempofor® gate is also offered in manual execution. Wing is equipped with hook lock and ear for padlock. Lock post with lock catcher.



## 4. Installation guidelines

Usage of automatic gate is related with safety requirements.

All the movement area must be closed to avoid risk of putting hand between fixed fence and moving wing.

You can use curtains f.e SAP: 7036578 or 7036507

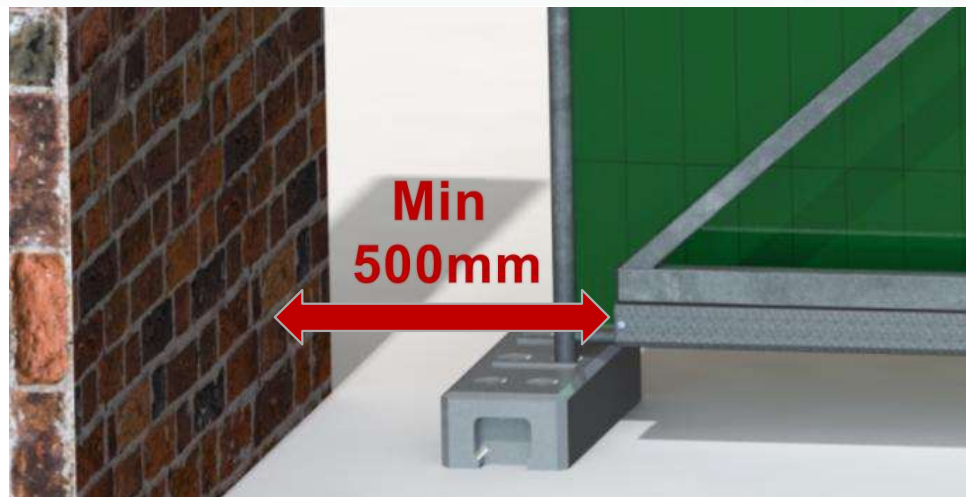
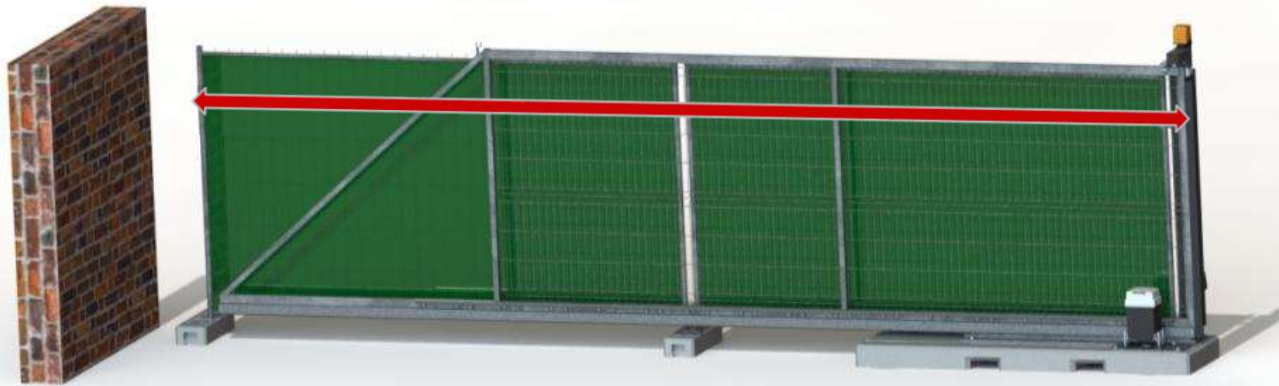

Minimum distance of 500mm from end of fully opened gate to first fixed obstacle must be kept.

## 4. Installation guidelines

Curtains fixed on the mobile panels cause heavy wind-load. Please take that in mind local wind conditions to assure stability of the panels.

If there is enough space we recommend to use brace posts:



**Brace** SAP 7002916 strong version  
SAP 7069002 light version

- improved stability
- essential in combination with curtain
- delivered with standard connector and ground pin



If the space is limited, You can use the anti-lift device and add more concrete base plates.



**SAP 7002908**

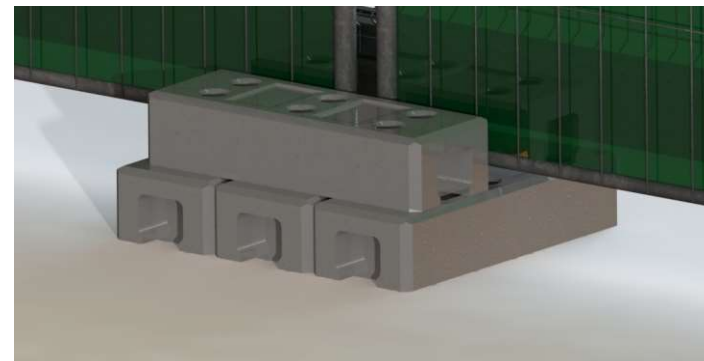



## 5. Advantages for the end user/installer

### Advantages for END USER

- ✓ Easy use
- ✓ Robust design
- ✓ High reliability
- ✓ Integrated functionality
- ✓ Proven technology
- ✓ Optimal price-quality ratio

### Advantages for INSTALLER

- ✓ Easy connection and start-up
- ✓ Allowing a competitive offer to the final customer

## 6. Ordering data

	Opening direction	Material	SPG group	Material Description
AUTOMATIC	Right	7071369	713V	SLG TEMP N3D 500x187 AUT R GA 746
	Left	7071370	713V	SLG TEMP N3D 500x187 AUT L GA 746
MANUAL	Right	7072905	713G	SLG TEMP N3D 500x187 MAN R GA
	Left	7072907	713G	SLG TEMP N3D 500x187 MAN L GA

As a standard 1 remote controller is delivered with an automatic gate.



Additional remote controllers can be ordered on separate line:  
1018203 REMOTE XT2 868 SLH LR BLACK FAAC LOGO

**9 complete gates fit into standard truck.**

## 7. Radio receiver FAAC – „master” remote controller programming

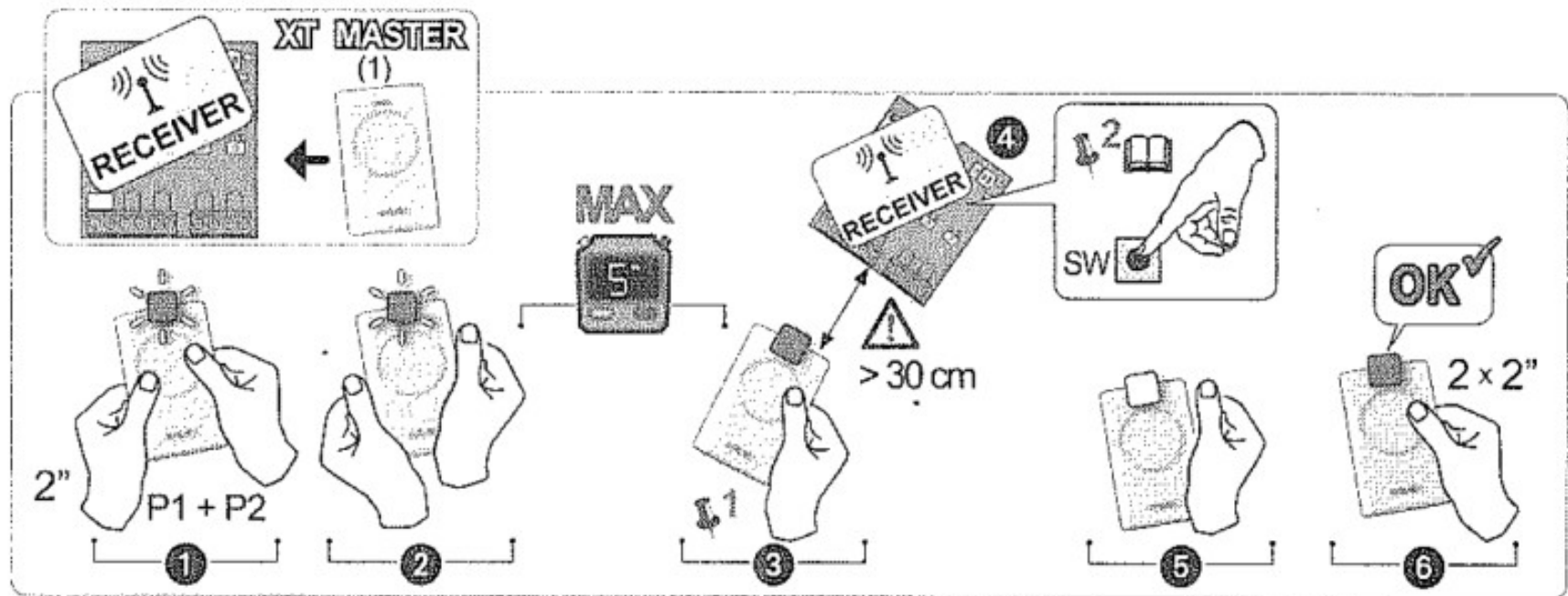

- 1) Push and hold both remote controller buttons for 2 seconds.  
Led on the remote control will blink.
- 2) Within max. 5 seconds, holding remote controller in distance not lower than 30 cm push and hold the button you will programming.
- 3) Push „SW” button on radio module.
- 4) Release the button on remote controller.
- 5) Push twice for 2 seconds the programmed button.

## 7. Radio receiver FAAC – remote controller programming from remote controller

Below link to movie how to program remote controller from remote controller  
[https://www.youtube.com/watch?v=X2ffKXunXyY&feature=player\\_embedded](https://www.youtube.com/watch?v=X2ffKXunXyY&feature=player_embedded)

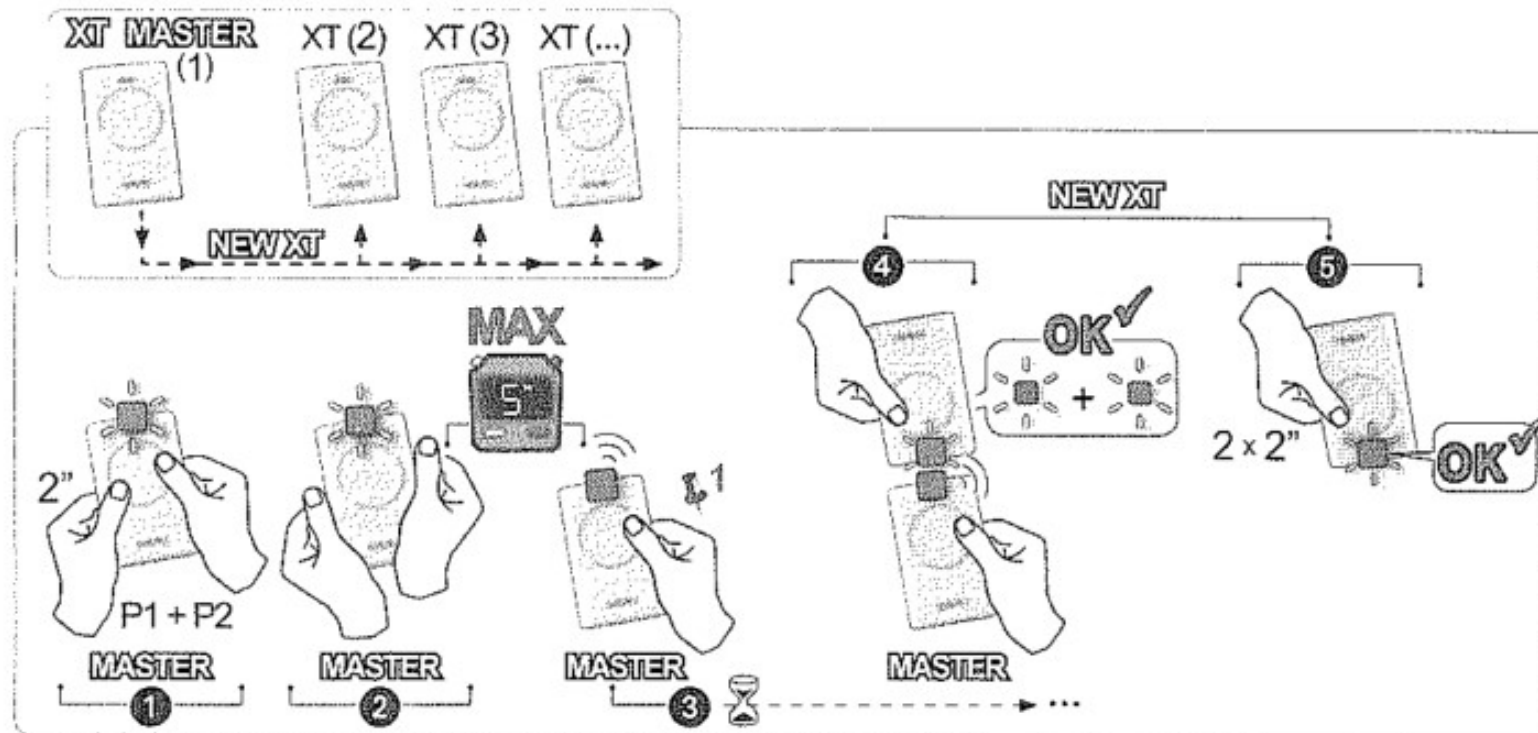

- 1) Push and hold both remote controller buttons for 2 seconds. Led on the remote control will blink.
- 2) Within max. 5 seconds, holding remote controller in distance not lower than 30 cm push and hold the button you will programming.
- 3) Push twice for 2 seconds the programmed button.

## 8. Pictures



## 8. Pictures



## 8. Pictures



## 8. Pictures





## 8. Pictures



## 8. Pictures



## 8. Pictures

