



# User Manual

Appropriate professional training is absolutely essential prior to use. This manual is NOT a substitute for appropriate professional training.

**THIS MANUAL IS NOT A SUBSTITUTE FOR APPROPRIATE PROFESSIONAL TRAINING. IT IS A REFERENCE FOR ASSEMBLY AND BASIC OPERATION OF THE BUTTERFLY LIFT BY TRAINED USERS.**

**DO NOT ATTEMPT TO TRAIN YOURSELF IN THE USE OF THE BUTTERFLY LIFT FROM THIS MANUAL.**

#### **DISCLAIMER**

**ROCK EXOTICA AND ITS AFFILIATES ARE NOT RESPONSIBLE FOR ANY DIRECT, INDIRECT, PUNITIVE, INCIDENTAL, SPECIAL OR CONSEQUENTIAL DAMAGES, TO PROPERTY OR LIFE, WHATSOEVER ARISING OUT OF OR CONNECTED WITH THE USE OR MISUSE OF OUR PRODUCTS.**

#### **ASSUMPTION OF RISK**

**RIGGING AND PERFORMER FLYING ARE INHERENTLY DANGEROUS AND CARRY A SIGNIFICANT RISK OF INJURY OR DEATH THAT CANNOT BE ELIMINATED. DO NOT USE THIS EQUIPMENT UNLESS YOU CAN AND WILL UNDERSTAND AND ASSUME ALL RISKS AND RESPONSIBILITIES FOR ALL DAMAGE/INJURY/DEATH THAT MAY RESULT FROM USE OF THIS EQUIPMENT OR THE ACTIVITIES UNDERTAKEN WITH IT. YOU MUST PERSONALLY UNDERSTAND AND ASSUME ALL RISKS AND RESPONSIBILITIES OF USING THIS EQUIPMENT. IF YOU CANNOT OR DO NOT WANT TO DO THIS, DO NOT USE THIS EQUIPMENT.**



**We strongly recommend registering your Butterfly Lift at [www.rockexotica.com/register](http://www.rockexotica.com/register)**

**Upon registering, we will be able to contact you regarding important product updates and information.**



**WARNING:** This product can expose you to chemicals including nickel acetate, which is known to the State of California to cause cancer. For information go to [WWW.P65Warnings.ca.gov](http://WWW.P65Warnings.ca.gov)



**ROCK EXOTICA**  
ISO 9001:2008

#### **Rock Exotica LLC**

POB 160470  
Freeport Center, Building E-16  
Clearfield, UT 84016 · USA  
801 728-0630

**BL1 500 08/2018 F**



#### **WARNING - FOR EXPERT USE ONLY!**

- Rigging and performer flying are inherently dangerous and carry a significant risk of injury or death that cannot be eliminated.
- Appropriate professional training in the field of application is essential before use.
- Attaching the Butterfly Lift to a structure requires skills and expertise beyond the scope of this manual. The user must have the required skills and knowledge to perform this task or must consult the appropriate qualified professional (e.g. Aerial Rigger, Structural Engineer).
- Assembly, inspection and operation must be done by individuals who have successfully completed appropriate professional training and accept responsibility for judging their own competence in performing the above tasks. It is the responsibility of the owner of this equipment to ensure these tasks are performed by individuals who have successfully completed appropriate professional training.
- Do not use this equipment unless you can and will understand and assume all risks and responsibilities for all damage/injury/death that may result from use of this equipment or the activities undertaken with it.
- Any device is subject to failure from fatigue, overloading, misuse, etc. Carefully check all parts and components of this equipment before and after each use.
- Everyone using this equipment must thoroughly understand the instructions and refer to them before each use.
- In the event the system is disabled or the performer is injured, you must have a primary and secondary rescue plan and the means to implement it. Inert suspension in a harness can quickly result in death!
- Do not use around electrical hazards, moving machinery or near sharp edges or abrasive surfaces.
- Stay up to date! Regularly go to our website, [www.rockexotica.com](http://www.rockexotica.com), and read the latest user instructions and product updates.
- ROCK EXOTICA AND ITS AFFILIATES ARE NOT RESPONSIBLE FOR ANY DIRECT, INDIRECT, PUNITIVE, INCIDENTAL, SPECIAL OR CONSEQUENTIAL DAMAGES, TO PROPERTY OR LIFE, WHATSOEVER ARISING OUT OF OR CONNECTED WITH THE USE OR MISUSE OF OUR PRODUCTS.





EXPERT USE ONLY



## REQUIREMENTS

To install this system you must have access to suitable overhead attachment points capable of resisting all forces including any dynamic events you will apply to the Butterfly Lift Payload line. The overhead attachment points must also resist lateral forces that include resultant angles and forces from the load or performer swinging. Consult a professional to determine the suitability of the attachment points.

To install this system, you must either have suitable floor anchors or ballast adequate to secure the Base Plate assembly. The ballast weight required is at least four times the payload weight.

Generally, the amount of counterweight required is equal to the payload minus the weight of the empty counterweight case (40 lb or 18 kg).  
(Payload - 40 lb = suggested counterweight)

For multiple person acts, maintain less than a 90 lb (40.8 kg) differential between the total counterweight (counterweight case + counterweight) and the payload (performer + apparatus).

**NOTE:** Rigging and performer flying are inherently dangerous activities and carry a significant risk of injury or death that cannot be eliminated. Both operator and performer must have successfully completed appropriate professional training in the use of the Butterfly Lift system. Live movement on aerial apparatus creates potential hazards not encountered on static apparatus. Performers should never attempt to fly on this system without first successfully completing appropriate professional training. Being at height is dangerous and it is up to you to reduce the risks as much as possible - but the risks can never be eliminated. There are many ways to misuse this equipment, too many to list or imagine. Users must personally understand and assume all risks and responsibilities of using this equipment. If you cannot or do not want to do this, do not use this equipment.

## RATINGS

Butterfly Lift components are designed to work as a system and are not rated individually. Use of Butterfly Lift components outside of the system is prohibited.

System Minimum Breaking Strength (MBS) = 4,000 lbf (17.7kN)

Working Load Limit (WLL\*): 350 lb (158 kg). (Static weight of performers and apparatus)

Maximum Total Counterweight = 350 lb (158 kg)

Maximum differential between payload and total counterweight must be less than 90 lb (40 kg)

\*Working Load Limit is based on about an 11:1 static system design factor, you must decide if this is sufficient or if you need to reduce your Working Load Limit (WLL).

## SPECIFICATIONS

BFL Case weight with components: 70 lb (31.7 kg)

Folding Base Plate and bag: 30 lb (13.6 kg)

Total rope weight (2): 22.7 lb (10.2 kg)

Counterweight Line: 5/8" (16 mm) diameter x 120' (36.5 m)

Payload Line: 7/16" (11mm) diameter x 120' (36.5 m)

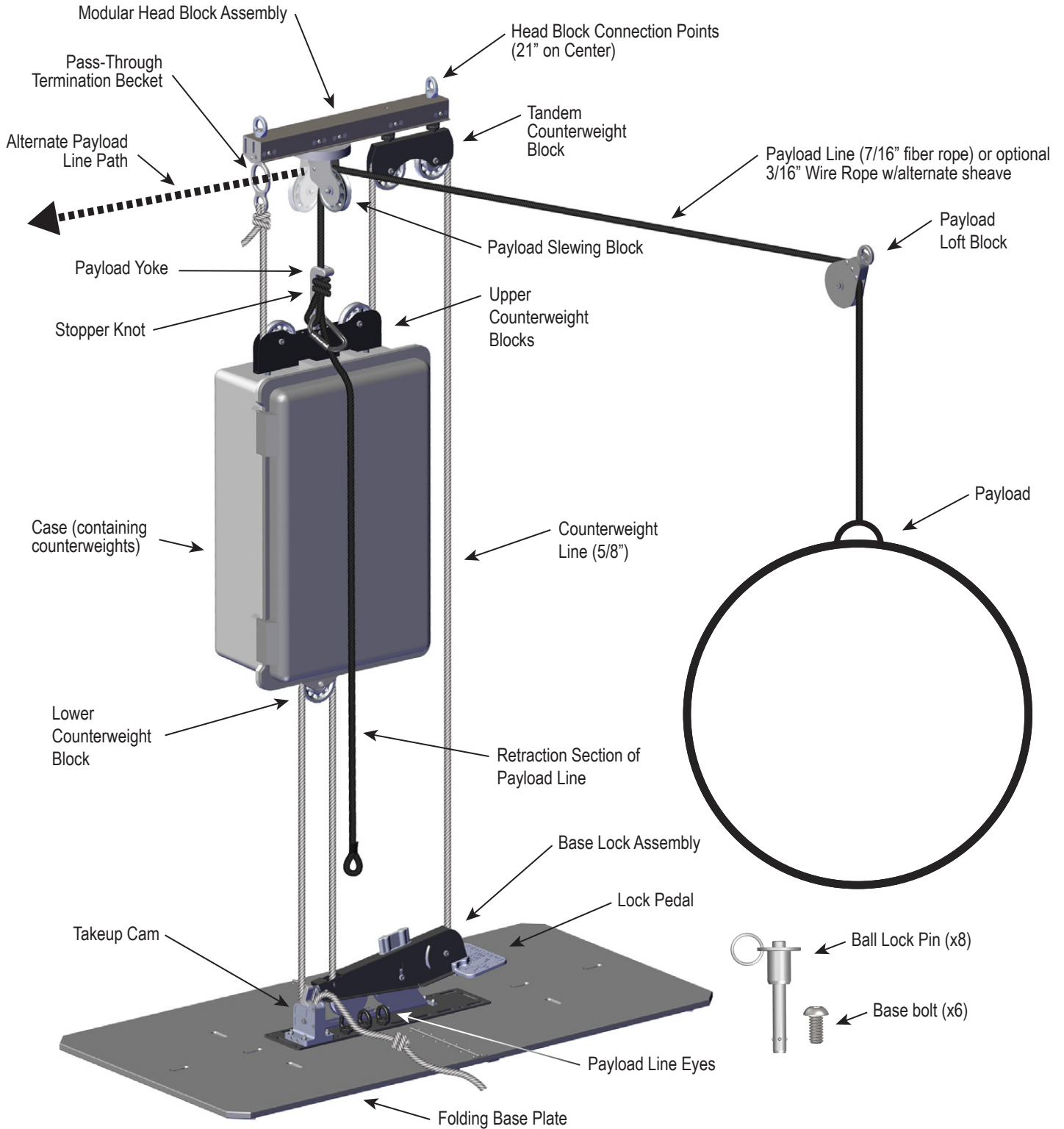

## INSPECTION PRIOR TO USE

- Inspect all parts for dents, cracks, deformations, warping, corrosion, wear of more than 10% or other signs of excess wear.
- Inspect and check the security of all bolts, screws and set-screws.
- Inspect all blocks and pulleys. Verify that the swivel top (**fig. A1**) rotates normally and the axle screw (**fig. A2**) has not loosened. Verify smooth rotation of the sheaves and security of the sheave's axle screw (**fig. A3**).
- Inspect the Take-Up Cam. Ensure that the Jaw rotates smoothly, that the proper spring action is present & that the jaw operates freely over its entire range of travel (**fig. B**).
- Inspect the Counterweight and Payload lines, referring to rope manufacturer's guidelines for inspection, maintenance and care.
- Inspect both the upper (**fig. C**) and lower (**fig. D**) counterweight block studs for cracks (especially in and around the welds), deformation or excessive wear.
- Inspect the payload yoke for cracks, deformation, or excessive wear. Verify the security of the axle screws and that the yoke rotates normally (**fig. E**). If you have any concerns about the strength or security of the unit or parts do not use.

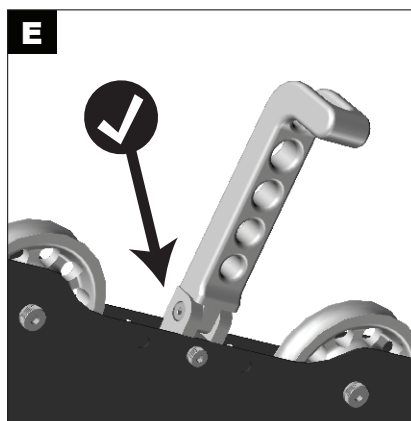
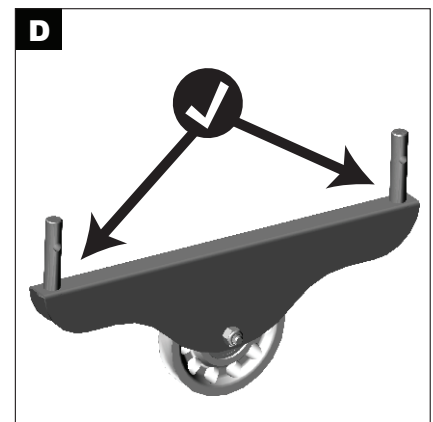
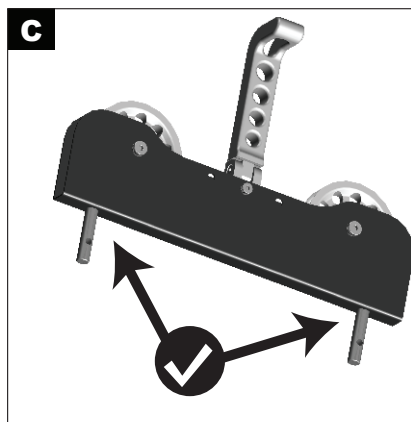
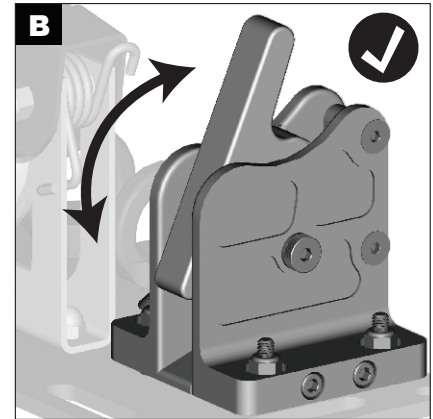
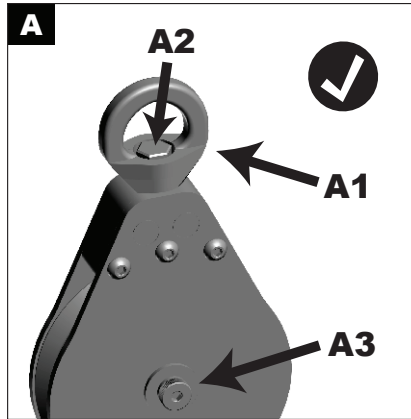

## PRE ASSEMBLY PREPARATION

The Butterfly Lift may be used with improvised counterweights such as concrete or sand bags, as well as with traditional theater counterweights.

If the system is to be used with improvised counterweight, the internal frame rods inside the case should be left at the factory spacing of 16" apart (**Fig. P1**).

If using theatrical steel weights, the internal counterweight frame (arbor) should be removed from the case and re-assembled with the rods spaced 10" apart (**Fig. P2**). This will accommodate the notched ends of the standard theater counterweights.

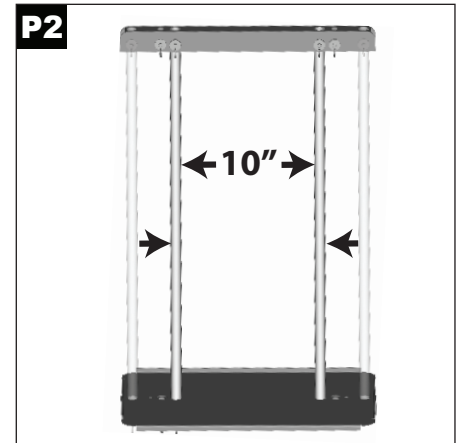
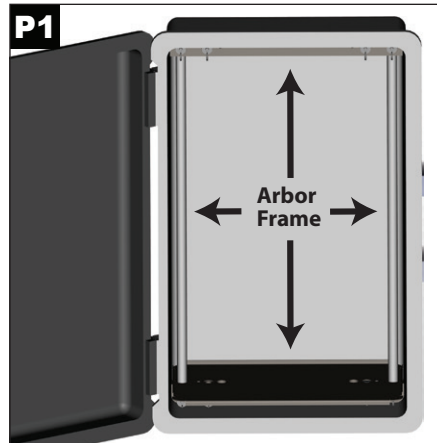

- 1) Pull the frame from the case.
- 2) Remove all four ball lock pins holding the rods to the frame top and bottom.
- 3) Move the rods to the holes spaced 10" apart.
- 4) Secure the rods with all four ball lock pins.
- 5) Place the internal frame in the case, ensuring that the sheet-metal weight rack is at bottom (the case end that has the external wheels).

**NEVER ATTEMPT TO USE THE BUTTERFLY LIFT WITHOUT ALL BALL LOCK PINS SECURELY IN PLACE!!**

## BASIC ASSEMBLY & INSTALLATION

# STEP 1

## Securing the Lock Pedal Assembly to the Floor

The Base Lock Assembly may be secured to the floor by one of two methods: 1) using the provided folding Base Plate plus improvised ballast or 2) direct fastening to a concrete floor using suitable hardware.

### Securing with Base Plate (fig. 1a)

Align the six mounting holes on the base lock assembly with the matching holes on the Base Plate. Install all six 3/8" bolts and tighten securely. For long-term setup, we recommend using Loctite.

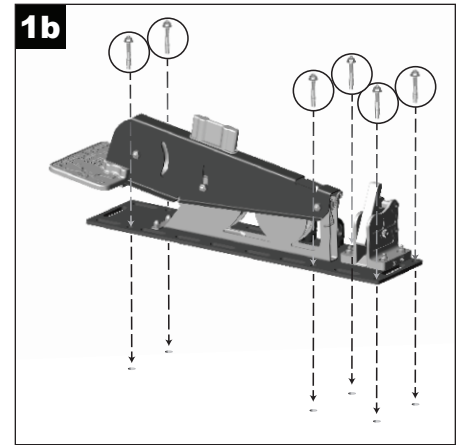
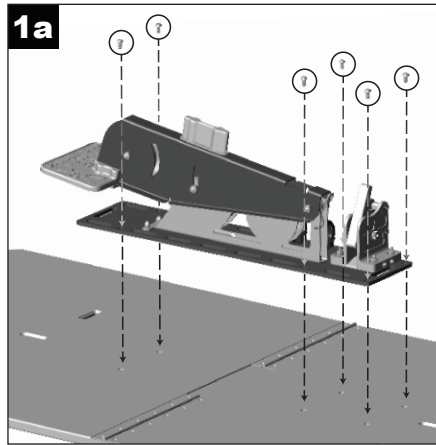

The base plate must be secured to the floor with ballast equal to at least 4 times the weight of the largest payload to be lifted. The available ballast slipcovers are intended for use with dry bagged concrete mix up to 80 lb.

As a general rule, stack 2/3 of the ballast on the left side of the baseplate when standing in front of the counterweight case, and 1/3 on the right, or pedal side, of the baseplate. Secure the ballast from slipping off by using the provided cam straps reeved through the available slots on the base plate.



### Direct fastening (fig. 1b)

*Note: you must install the Base Lock directly below the Head Block assembly. This may be easier to accomplish once the system is rigged to the structure.*

Locate the base plate and lock assembly directly under the position where the Head Block assembly will mount. See **fig 1c** to determine which way the lock pedal should point.

## STEP 2

### Installing Upper Block on Counterweight Case

Find the Upper Counterweight Block Assembly with the Payload Yoke and two studs protruding from the cheek plates. This assembly mounts on the top of the case.

Orient the Payload Yoke upward (toward head block assembly). Slide the Upper Counterweight Block Assembly studs into the matching holes on the case. The studs must insert through the case wall into the matching holes in the internal frame. See **fig. 2a**.

When the Upper Counterweight Block Assembly Studs are fully inserted into the internal frame, use the provided Ball Lock Pins to secure both studs to the internal frame. See **fig. 2b**.

NEVER ATTEMPT TO USE THE SYSTEM WITHOUT ALL BALL LOCK PINS SECURELY IN PLACE!

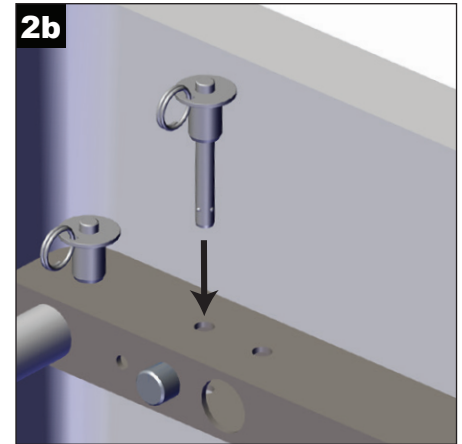
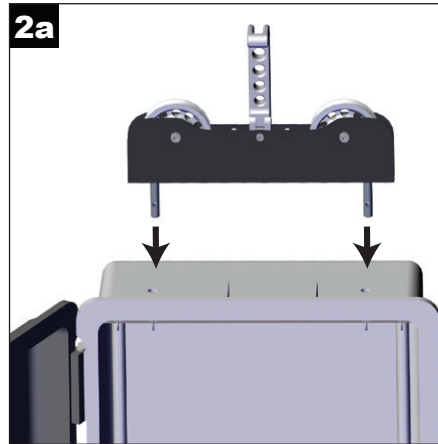



## STEP 3

### Installation of Counterweight Line into Head Block Assembly & Upper Counterweight Block

Begin reeving the Counterweight Line through the Tandem Counterweight Blocks on the Head Block Assembly as shown in **fig. 3a**.

Next, reeve the Counterweight line back through the Upper Counterweight Case Blocks as shown in **fig. 3b**.

Continue to reeve the Counterweight Line up toward the Head Block Assembly. Use an appropriate termination knot, splice, or connector to terminate the Counterweight Line to the Termination Becket. See **fig. 3c**.

**It is the user's responsibility to ensure the security of the connection between the counterweight line and the termination becket. A round turn with two half hitches is one example of an appropriate knot.**

#### Checkpoint

The Counterweight Line should be reeved through the Tandem Head block, the Upper Counterweight Case Blocks and terminated back to the Termination Becket shown in **fig. 3d**.

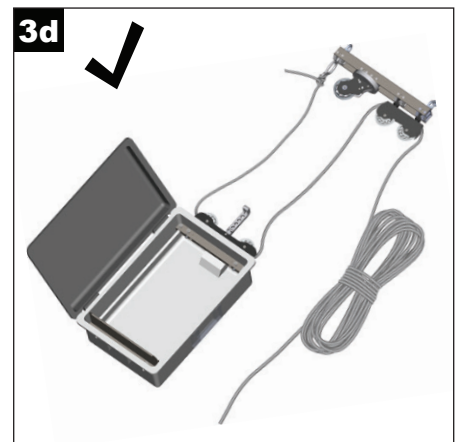
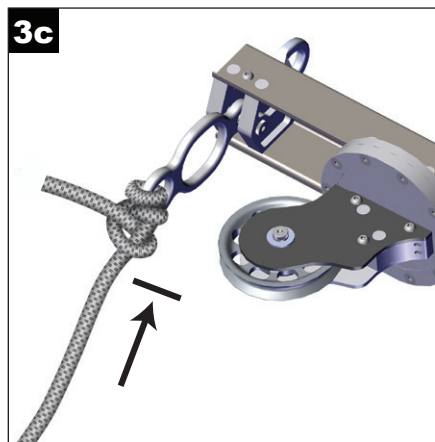
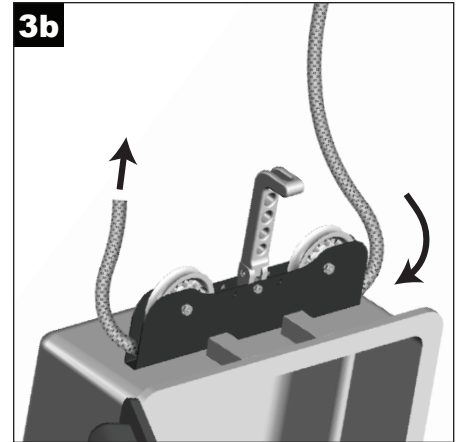
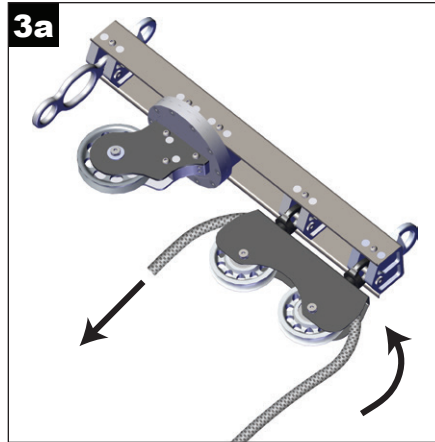

## STEP 4

### Preliminary Installation of the Payload Line

**Note:** The Butterfly Lift system includes a 7/16" fiber rope Payload Line. Any alternative selection and fabrication of the Payload lines are the responsibility of the end user. It is not possible for Rock Exotica to specify the appropriate cordage and terminations for every foreseeable application. Rock Exotica does not provide termination hardware for the Payload Lines. Keep in mind that the type and size of the Payload Line may require you to reduce your working load limit (WLL). Follow all pertinent manufacturer's instructions and recommendations for the Payload Line and termination hardware used.

Reeve the provided 7/16" Payload Line up through the Payload Yoke shown in **fig. 4a** and up through Payload Slewing Block shown in **fig. 4b**.

If the payload is parallel in relation to the Head Block Assembly, it will be necessary to pass the Payload Line through the Pass-Through Termination Becket shown as an alternate line path in **fig. 4b**. Otherwise, the Slewing payload block is free to orient toward the payload.

Reeve the Payload Line through the Payload Loft Block as shown in **fig. 4c** and terminate the end of the Payload Line with an appropriate knot, splice or connector as shown in **fig. 4d**. **Note:** Tie a temporary retrieval cord to the Payload Line to prevent the Payload Line from slipping out of reach, back through the Payload Loft Block. The retrieval cord will also assist in setting the trim height in later steps. The retrieval cord length should equal the structure height.

#### Checkpoint:

The Counterweight Line should be reeved through the Tandem Head Blocks, Upper Counterweight Blocks and terminated at the Pass-Through Termination Becket. The Payload Line should be reeved up through the Payload Yoke, through the Slewing Payload Block, through the Payload Loft Block and terminated as shown in **fig. 4e**.

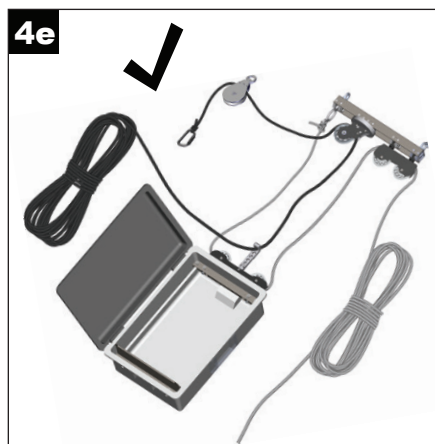
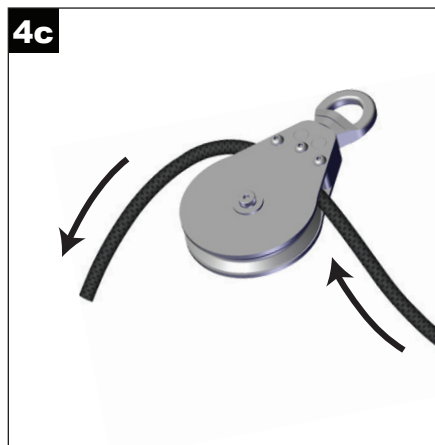
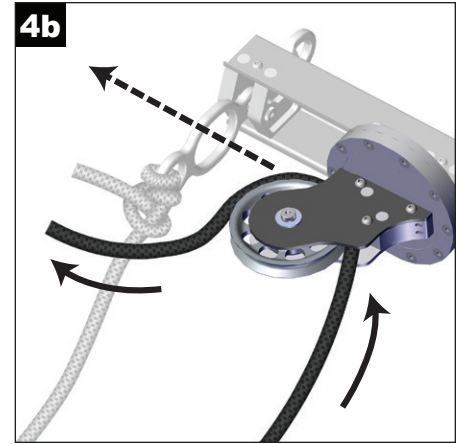
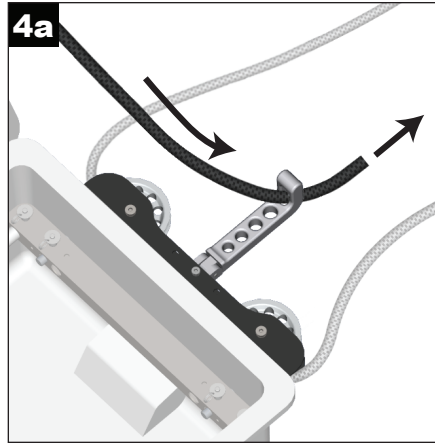

## STEP 5

### Attaching Head Block Assembly & Raising the Butterfly Lift

#### Base Lock Counterweight Line Installation:

Feed the end of the Counterweight Line into the gap between the pedal and the pulley shown in **fig. 5a**. Continue feeding the rope under the cam in the lock assembly. Using the finger holes, turn the rope up around the second (static) pulley. It may be necessary to steady the cam by hand. Pull roughly 12' - 15' of rope through the lock.



ATTACHING THE BUTTERFLY LIFT TO A STRUCTURE REQUIRES SKILLS AND EXPERTISE BEYOND THE SCOPE OF THIS MANUAL. THE USER MUST HAVE THE REQUIRED SKILLS AND KNOWLEDGE TO PERFORM THIS TASK OR MUST CONSULT THE APPROPRIATE QUALIFIED PROFESSIONAL (E.G. AERIAL RIGGER, STRUCTURAL ENGINEER).

THE USER IS RESPONSIBLE FOR VERIFYING THE SUITABILITY OF THE STRUCTURE AND ITS ABILITY TO RESIST THE LOADS APPLIED!

THE USER IS RESPONSIBLE FOR DETERMINING AND USING APPROPRIATE ATTACHMENTS FOR THE STRUCTURE TYPE AND APPLICATION! CONSULT THE APPROPRIATE QUALIFIED PROFESSIONAL (E.G. AERIAL RIGGER, STRUCTURAL ENGINEER)!

#### Rigging the Head Block Assembly to the overhead structure:

Keeping the Head Block Assembly in the correct orientation, raise to the desired rigging position. Take care not to twist or rotate the assembly when lifting it. Do not allow the Counterweight Line and/or Payload Line to become twisted, tangled or kinked.

Attach the Head Block Assembly to the structure using both of the attached eyes and suitable slings, chafing protection, and connection hardware. See **fig. 5b**.

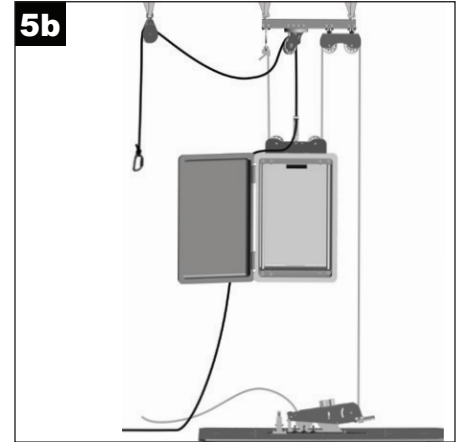
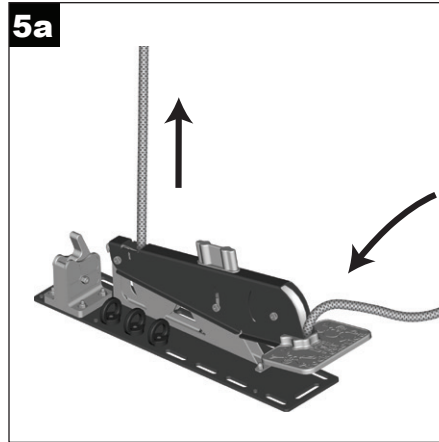

Raise the Payload Loft Block and attach it to the structure using the attached eye and suitable slings, chafing protection, and connection hardware. See **fig. 5b**.

#### Floating the counterweight case to working height:

Take hold of the section of Counterweight line that descends from the Head Block Assembly Tandem Blocks. Pull down on the section of line until the Counterweight Case starts to rise.

Guide the Counterweight Case gently off the ground until it is about 3' above the floor. Step on the Base Lock Pedal. Pull the tail end of the Counterweight Line through the cam until all slack is removed. Lift your foot off the Base Lock Pedal, allowing the lock to engage. The Counterweight Case is now supported by the locking mechanism of the Base Lock Assembly.

## STEP 6

### Final Installation of the Counterweight line

**Install the Lower Counterweight Block:**

Find the Lower Counterweight Block with the two studs protruding from the cheek plates. This assembly mounts to the bottom of the case as shown in **fig. 6a**.

Slide the studs on the Lower Counterweight Block into the matching holes on the case.

The studs must insert through the case wall into the matching holes in the internal frame. When the Lower Counterweight Block assembly studs are fully inserted into the internal frame, use the provided ball lock pins to secure both studs to the internal frame shown in **fig. 6b**.

Pass the end of the rope through the Lower counterweight block shown in **fig. 6c** and then down into the lower mouth of the Take-up Cam on the Base Lock Assembly shown in **fig. 6d**. Pull remaining rope through the Take-up Cam and tie a knot in the first eye as shown in **fig. 6d**. A round turn with two half hitches is one example of an appropriate knot.

From time to time it may be necessary pull more rope through the cam to take up slack.

**Checkpoint:**

The Counterweight Line is fully installed as shown in **fig. 6e**, and the Payload Line is ready to be adjusted.

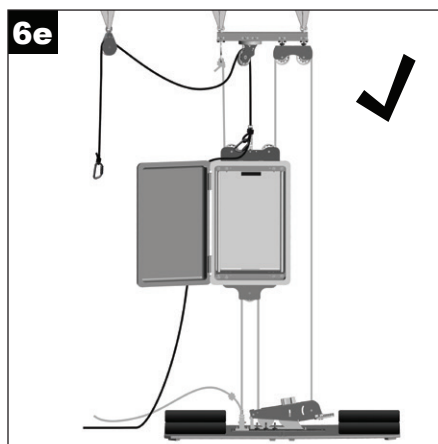
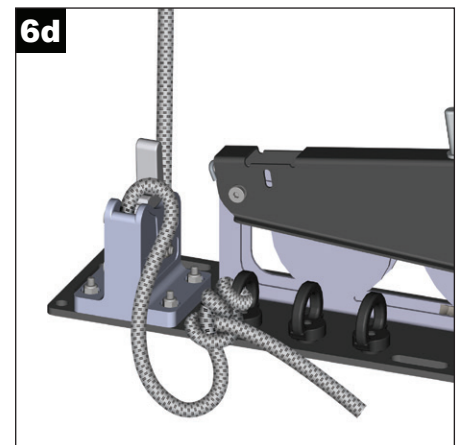
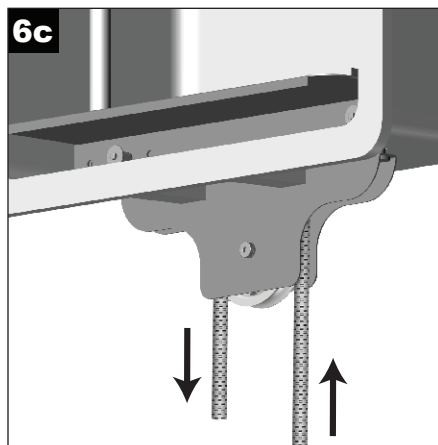
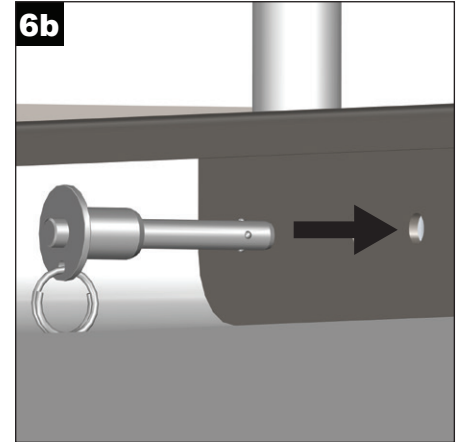
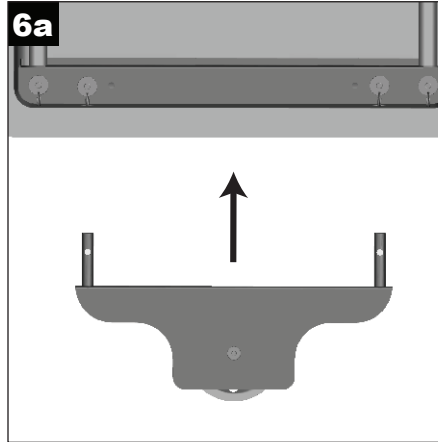



## STEP 7

### Adjusting and Terminating the Payload Line

With the Counterweight Case about 3'-4' above the ground, pull the temporary retrieval line with the Payload Line end down to the desired level. The height will need to be sufficient to accommodate the performer and apparatus. Next, tie a stopper knot in the payload line that will engage the Payload yoke at height appropriate for the Payload end. An in-line figure 8 knot with a carabiner is an example of an appropriate stopper knot. See **fig 7a**.

You may now remove the temporary retrieval cord and knot or terminate the Payload Line approximately 4' above the floor or the desired height of the apparatus.

When the Butterfly Lift is assembled, the Payload Line used must have an appropriate termination on three key parts on the line: the payload or performer end; a secure midline stopper or end stopper to engage the Load Yoke; and a secure eye below the stopper.

If using the Rock Exotica Wire Rope Kit, follow the separate instructions for correct installation.

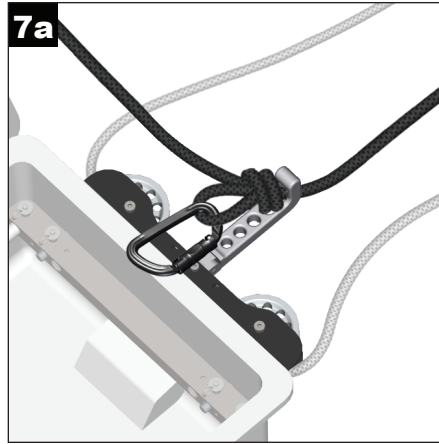

The Butterfly Lift is now assembled and installed.



EXPERT USE ONLY



## OPERATING THE LIFT

### Loading the Counterweight

Take hold of the Counterweight Line and pull down slightly. Simultaneously, step on the Base Lock Pedal, releasing the lock.

Lower the Counterweight Case in a controlled manner to approximately 3' above the floor. Raise your foot, locking the system. (Note as you lower the Counterweight Case, the payload end ascends).

We recommend adding another rope to the payload end at this point to assist with setting the counterweight.

The Counterweight Case itself weighs 40 lb (18 kg). Add appropriate counterweight to the Counterweight Case. (Payload - 40 lb = suggested counterweight)

When using improvised weights such as sand bags, raise the fabric Restraint, insert the weights, then lower the Restraint. If using standard theatrical steel weights, the Restraint may be removed. Close and latch the counterweight case.

**Exact weighting of the Counterweight Case will change based on the needs of the act. Starting weighting should be:**

(Performer(s) + Apparatus) = Payload

Payload - 40 lb = Suggested Counterweight

*Note: the Counterweight Case weighs 40 lb, therefore the amount of counterweight needed in the case is equal to the Payload minus the weight of the case or 40 lb.*

### Pre-Setting the System for Use

Depending on the amount of counterweight, building height, and the operator's strength, pre-setting the weight may require two people.

Take firm hold of the Counterweight Line and pull slightly, just enough to lift the weight an inch or two. Simultaneously, step on the Base Lock Pedal, releasing the lock.

Raise the Counterweight Case until the Payload Yoke is approximately 6" below the Payload Head Block, then raise your foot to set the lock before releasing the Counterweight Line from your hand. The Base Lock Assembly should now hold the fully weighted Counterweight Case. If you have the optional retracting cord installed on the Payload Line, secure it to one of the Accessory Eyes on the Base Lock.

### Standard Operation

Connect the payload, or the apparatus and have the performer mount the system.

Take hold of the Counterweight Line and pull down slightly. Simultaneously, step on the Base Lock Pedal to release the lock.

The performer may now be flown by pulling down on the "part of line" that pulls DOWN on the Counterweight Case. Pulling the Counterweight Case DOWN causes the performer to go UP.

The performer may be lowered by pulling DOWN on the "part of line" that RAISES the Counterweight Case. RAISING the Counterweight Case causes the performer to come DOWN.

When the performer is ready to dismount, raise the Counterweight Case until the Payload Yoke nears the Payload Head Block, and the performer approaches the floor. Raise your foot, allowing the lock to engage. The performer may then dismount.

If at any time the performer dismounts, unexpectedly unbalancing the system, control the Counterweight Line and remove your foot from the pedal allowing the lock to engage.

**Note:** *the purpose of the Base Lock is to hold the system stationary against any imbalance between the counterweight and the payload. When operating the lift the foot pedal should be fully depressed. Never try to use it with the foot pedal only partially engaged. The foot pedal must be fully depressed when operating, or all the way up (with your foot off it) to hold stationary.*

### Advanced Counterweight Methods

On occasion it may be necessary to fly a partially imbalanced load. Consider an example of a man weighing 180 lb and a woman weighing 110 lb flying together on an apparatus that weighs 50 lb (340 lb total). However, the choreography calls for the man to dismount and do floor moves while the woman is raised and lowered.

Once the man dismounts, the system will be imbalanced by 180 lb.

It is important to understand that the double-purchased Counterweight Line of the Butterfly Lift reduces the lifting effort of an imbalance by approximately half (not accounting for a small amount of friction in pulleys, etc.)



EXPERT USE ONLY



Thus, if you loaded all 340 lb into the Counterweight, the lifting effort would increase approximately 90 lb when the 180 lb man dismounted. The system would become too heavy, and the operator would struggle to prevent the woman flying upward as the excessive Counterweight descended.

A better alternative is as follows. Load the system for the full weight of the woman (110 lb), the full weight of the apparatus (50 lb) and half the weight of the man (load 90 lb in place of 180 lb for the man) for a total 250 lb.

When lifting the duo, the system will now be imbalanced by 90 lb. The counterweight will be too light by 90 lb. However, the line effort will be half that: 45 lb. In other words, it will require a 45 lb line effort to lift the man and woman together. Obviously the operator must have the physical strength to lift that weight, and in case of difficulty must have the ability to lift his/her foot to lock the system.

Next, the man dismounts. Now the counterweight is 90 lb too heavy. Reduced by half, the operator must use 45 lb of effort to prevent the woman flying upward. Again, the operator must have the strength to safely handle that, and in case of difficulty must remember to raise his/her foot, locking the system.

THE THEORETICAL VALUES MENTIONED IN THIS SCENARIO WILL DIFFER FROM ACTUAL VALUES BASED ON ROPE CONDITION, FRICTION THROUGH THE SYSTEM AND OTHER ENVIRONMENTAL FACTORS. COUNTERWEIGHT DIFFERENTIALS MUST BE CAREFULLY TESTED WITH WEIGHTS IN CONTROLLED CONDITIONS PRIOR TO USE WITH LIVE LOADS.



EXPERT USE ONLY



## WARNINGS

- Do not allow anyone who is not properly trained operate or use the Butterfly Lift!
- Do not exceed the Working Load Limit (WLL).
- Be cautions when opening the Counterweight Case as the contents may have shifted.
- Ensure the base is properly secured by either ballast weight or otherwise anchored to the floor. Attaching the Butterfly Lift to a structure requires skills beyond the scope of this manual. The user must have the required skills and knowledge to perform this task or must consult the appropriate qualified professional (e.g. Aerial Rigger, Structural Engineer).
- Never stand directly beneath the counterweight or allow anyone else to do so. If the counterweight is positioned above the operator, then the base plate assembly must be repositioned to correct this misalignment.
- Verify that ball lock pins are fully installed and the ball detent is exposed.
- Verify that you have adequate structure anchors, consult a professional!
- Always ensure the proper amount of counterweight before operation.
- Do not exceed 90 lb. imbalance during normal operations.
- Always apply a controlled test load prior to flying a performer to make sure the cam locks before use.
- Never release the lock pedal without a) knowing the force needed to operate the counterweight line, b) having physical ability to operate counterweight line, and c) gripping counterweight line securely.
- Never allow the system to unexpectedly start or stop with an unsecured performer on an apparatus. All moves with the system must be coordinated with the performer. If the system must be stopped for any reason, make sure the performer is aware of the stop and has a firm grip on the apparatus.
- Performer must not dismount the payload system before the lock is set.
- Operator must lock system prior to dismount of performer.
- Operator should always maintain grip on Counterweight Line while system is loaded or performer is attached. Always maintain control of the Counterweight Line while operating the Butterfly Lift.
- Operator must be able to sustain weight of unbalanced system at any time without warning.
- Operator must not add counterweight while a performer is attached to system.
- Operator must remain fully attentive to the planned movement of the performer. The operator must not allow any distraction to interrupt coordinated loading and unloading of system.
- Rope travelling through a pulley can pull in hair, fingers, clothing, etc., causing injury and jamming the pulley. Guard against this at all times.
- When left unattended, always lower the counterweight as much as possible, install the provided key locking pin and otherwise be sure no unauthorized person can use the system.





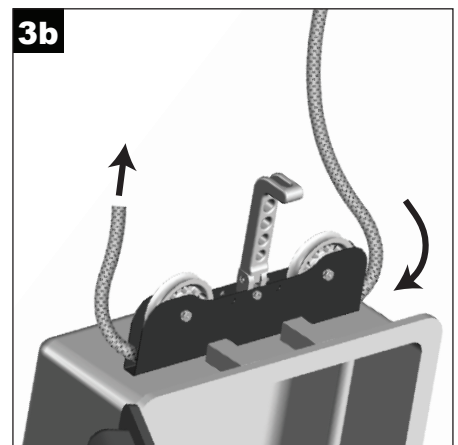
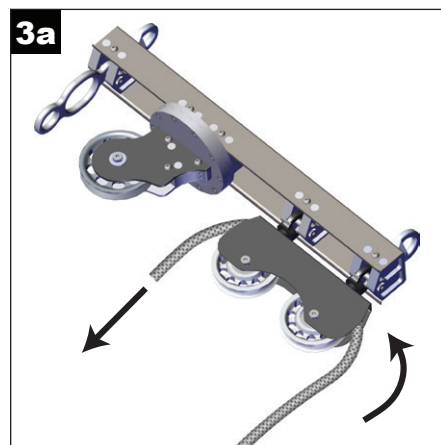
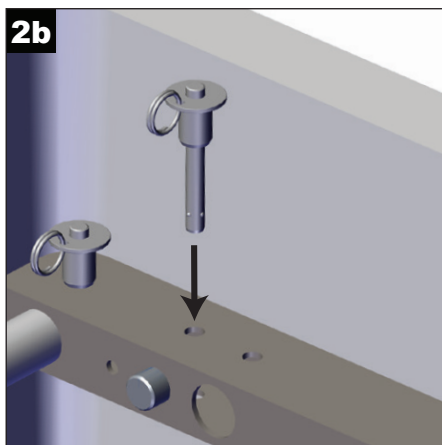
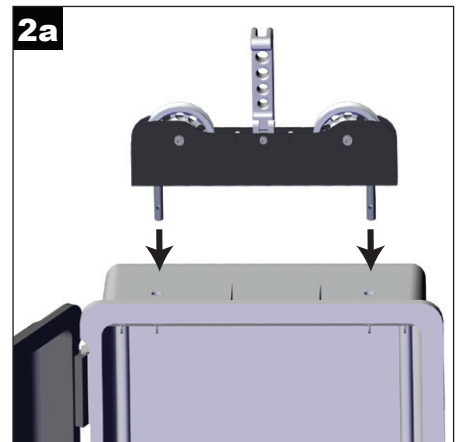
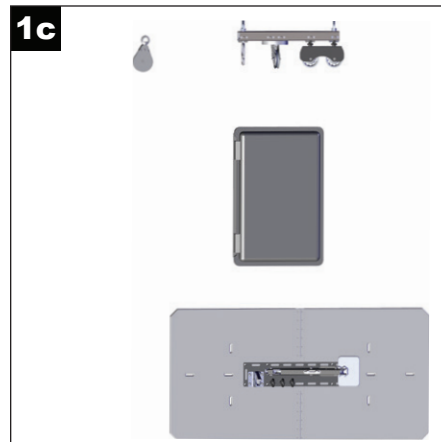
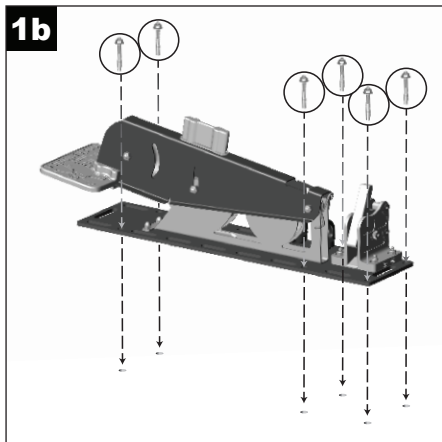
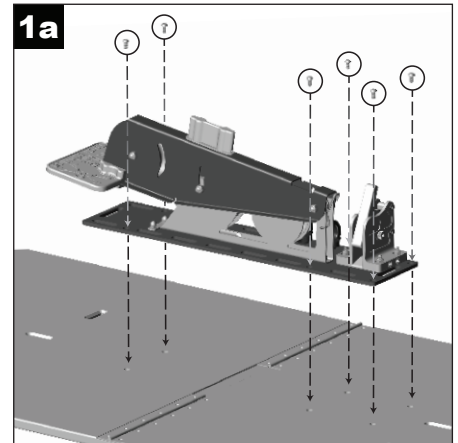
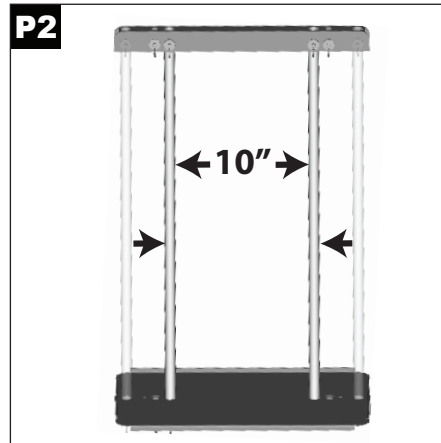
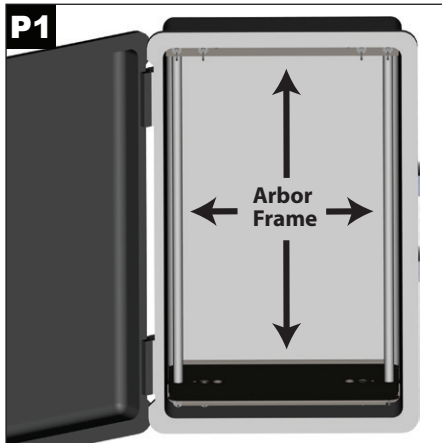

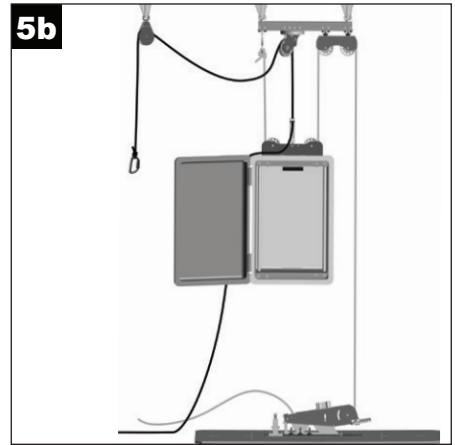
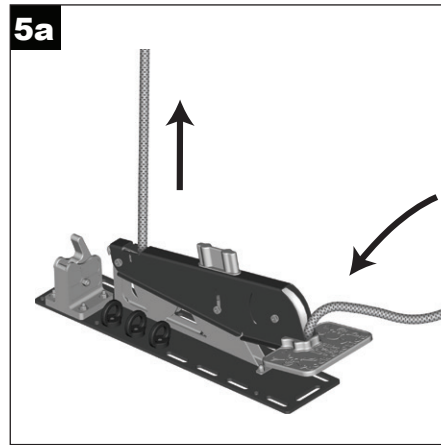
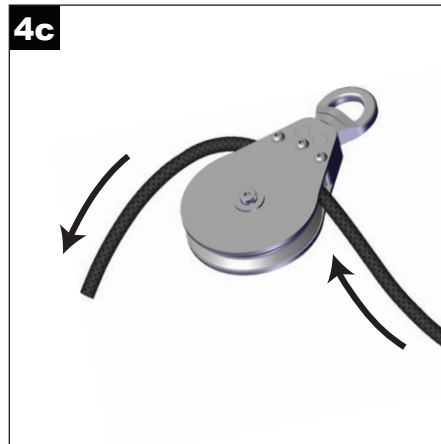
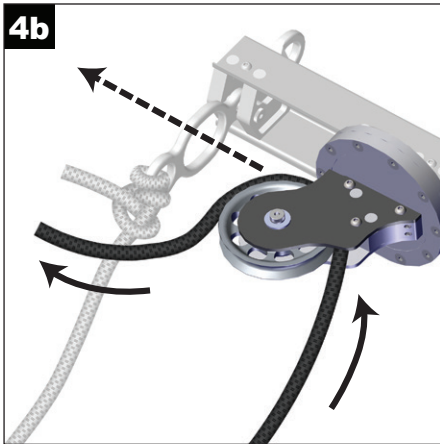
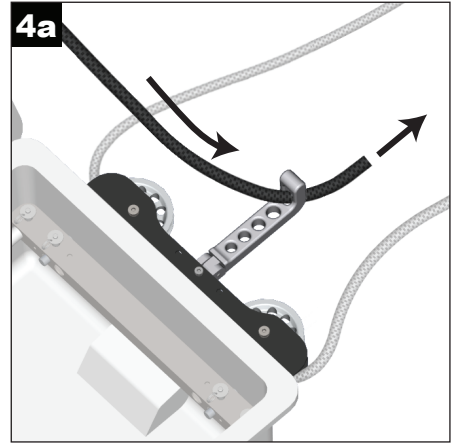
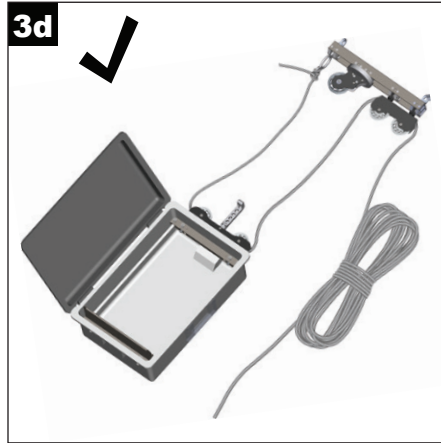
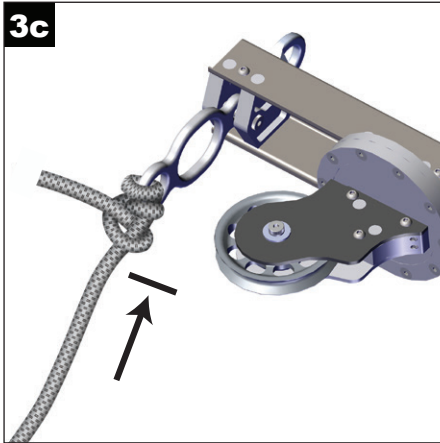

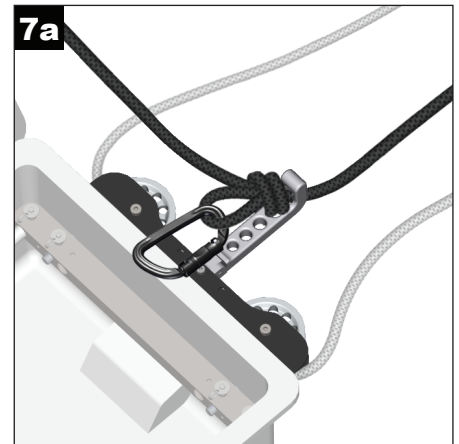
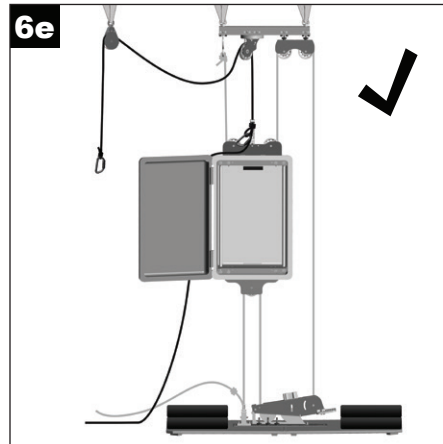
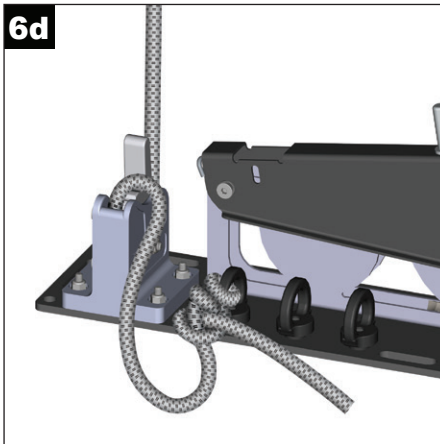
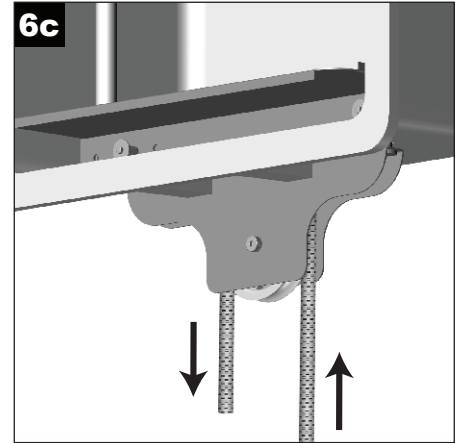
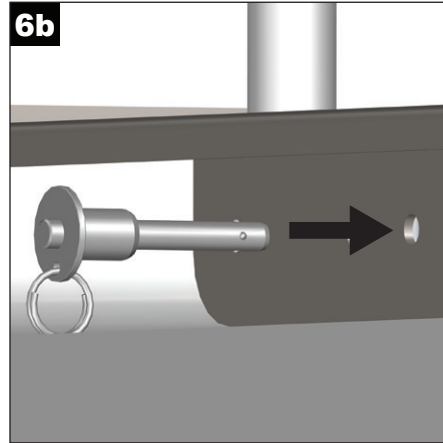
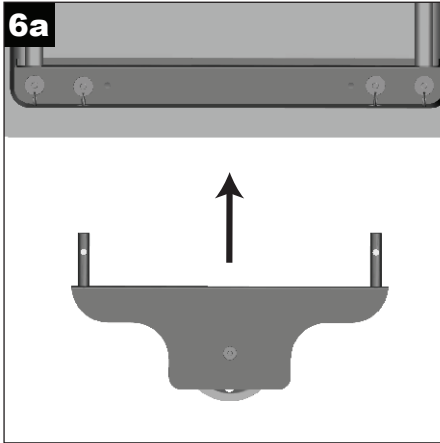





EXPERT USE ONLY

