

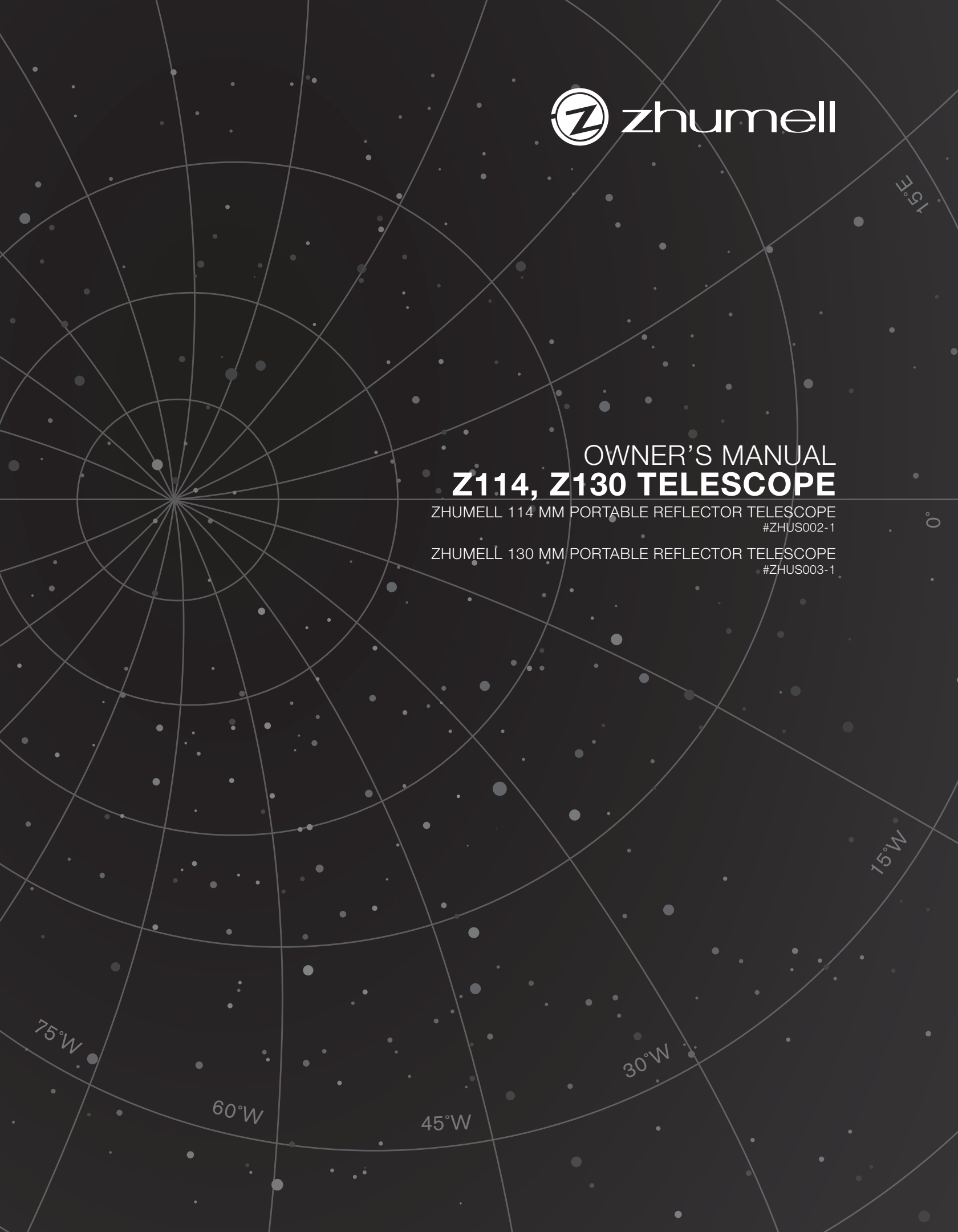

OWNER'S MANUAL  
**Z114, Z130 TELESCOPE**

ZHUMELL 114 MM PORTABLE REFLECTOR TELESCOPE  
#ZHUS002-1

ZHUMELL 130 MM PORTABLE REFLECTOR TELESCOPE  
#ZHUS003-1





**Zhumell customers know that there are plenty of ways to experience the world. They also understand that, however you choose to explore it, the best experience is one that fully immerses you in the world's most striking details.**

That's where our optics products come in. We strive to put high-performance products in the hands of our customers so that they can experience the world up close, with their own eyes.

With Zhumell, you get field-tested, precision-crafted optics at the best possible value. So even if you're just starting out as an amateur birder or astronomer, you don't have to settle for entry-level products. Zhumell customers enjoy life's pursuits, hobbies, and adventures in rich, colorful detail- the kind of detail that only high-performance optics can produce.

At Zhumell, we design our binoculars, telescopes, and spotting scopes for discerning, price-conscious users who are uncompromising on quality. If you're looking for accessibly priced optics that will bring your world within reach, you're looking for Zhumell.

### **ENJOY THE TELESCOPE.**

Zhumell telescopes are precision astronomical instruments designed for ease of use and versatility in their application. As with any telescope, Zhumell telescopes require some technical knowledge of stellar movement and optical properties. We have provided basic instructions for telescope use and astronomical viewing in this manual.

Your Zhumell telescope is built with the highest-quality optics and top-notch construction to provide years of reliable functionality, but will require proper care.

If, after reading this manual, you still have questions about your Zhumell telescope, please visit [www.zhumell.com](http://www.zhumell.com) for more helpful tips and contact information. Our customer service representatives are available to address any problems you encounter with your telescope. Please let us know about your experiences; we would like to hear your feedback.

# Z114, Z130 PORTABLE REFLECTOR TELESCOPE

<b>Caring For Your Telescope</b> .....	p.2
• Warnings	
• Cleaning and Maintenance	
<b>Specifications</b> .....	p.2
<b>Parts List</b> .....	p.2
<b>Overview</b> .....	p.3
<b>Assembling Your Telescope</b> .....	p.3
• Installing the Red Dot Finder	
• Tube Orientation	
• Z130 Eyepiece Tray Installation	
• Z130 Tube Disassembly	
<b>Telescope Basics</b> .....	p.4-5
• Using 1.25" Eyepieces	
• Altitude and Azimuth	
• Focusing the Image	
• Aligning your Red Dot Finder	
• Optical Alignment (Collimation)	
<b>Adjusting the Collimation</b> .....	p.6
• Secondary Mirror Adjustment	
• Primary Mirror Adjustment	
<b>Observation Tips for Your Telescope</b> .....	p.7
• Selecting a Viewing Site	
• Dark Adapting Your Eyes	
• Seeing and Transparency	
• Tracking Celestial Objects	
• Selecting and Eyepiece	
• The Moon	
• The Stars	
• The Planets	
• Deep Sky Objects	
<b>Astronomy Formulas</b> .....	p.10
• Magnification	
• Focal Ratio	
<b>Astronomy Terminology</b> .....	p.10
<b>Telescope Terminology</b> .....	p.11

# Z114, Z130 PORTABLE REFLECTOR TELESCOPE

## CARING FOR YOUR TELESCOPE

### WARNINGS

- Do not use telescope or finderscope to look at the sun without an appropriate solar filter. Doing so will cause permanent and irreversible eye damage.
- Never use an eyepiece filter as a solar filter. Only full aperture solar filters will completely cover the opening of the optical tube and provide proper eye protection.
- Make sure no screws are loose before using telescope.
- Do not drop or shake your telescope as doing so may damage the optics, or harm you or the people around you.

### CLEANING AND MAINTENANCE

Cleaning should be done as little as possible and then only with mild soap solution and a soft, lint-free cloth. Do not rub elements when cleaning. Blot optical components gently and allow telescope to air-dry. Store telescope in its box or in a telescope case when not in use. Do not use pure alcohol or solvents to clean any parts of the telescope. Do not remove optical elements from the telescope as doing so may affect the alignment of optical components when reassembled. If telescope needs realignment, contact Zhumell or another professional.

1. Brush telescope optics with camelhair brush or blow off dust with an ear syringe (can be purchased at any pharmacy). Do not use a commercial photographic lens cleaner.
2. Remove organic materials (e.g. fingerprints) with short gentle strokes using soft white tissue paper and a solution of three parts distilled water and one part isopropyl alcohol. You may also add one drop of biodegradable dish soap to one pint of the homemade solution. Do not use lotioned or scented tissues as they could damage the optics of your telescope.
3. Wipe down the outside of your telescope with a dry cloth or let air dry inside to remove condensation prior to packing up your telescope. Do not wipe any of the optical surfaces. Instead, allow the optics to dry naturally in warm indoor air prior to packing up your telescope.
4. Protect your telescope from excessive heat. For example, do not store your telescope in a sealed car on a warm day. Excessive storage temperatures can damage your telescope.

## SPECIFICATIONS

	Z114	Z130
Objective/Aperture	114 mm / 4.5"	130 mm / 5.1"
Focal Length	450 mm	650 mm
Limiting Magnitude	12.98	13.27
Focal Ratio	f/3.95	f/5.00
Eyepiece Format	1.25"	1.25"
Finderscope	Red Dot Finder	Red Dot Finder
Mount Type	Tabletop altitude-azimuth / Dobsonian	Tabletop altitude-azimuth / Dobsonian
Tube Mount	Tube clamp	Tube rings with dovetail rail
Mount Adjustments	Altitude-azimuth	Altitude-azimuth
Materials	Wood, Melamine	Wood, Melamine

## PARTS LIST

### Z114

- Optical tube assembly (preinstalled on base)
- Base assembly
- 17 mm eyepiece (1.25" format)
- 10 mm eyepiece (1.25" format)
- Red dot finderscope
- Phillips head screwdriver

### Z130

- Optical tube assembly (preinstalled on base)
- Base assembly
- 25 mm eyepiece (1.25" format)
- 10 mm eyepiece (1.25" format)
- Eyepiece Tray for three 1.25" eyepieces
- Red dot finderscope
- Phillips head screwdriver

# Z114, Z130 PORTABLE REFLECTOR TELESCOPE

## OVERVIEW

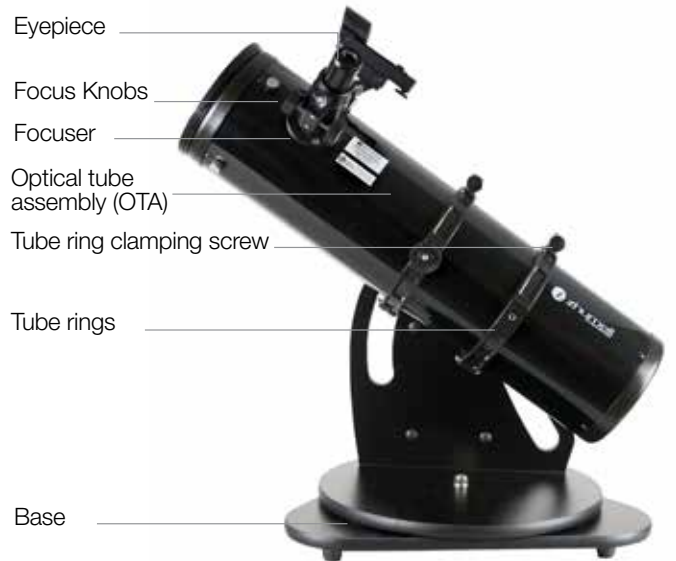

# Z114, Z130 PORTABLE REFLECTOR TELESCOPE

## ASSEMBLING YOUR TELESCOPE

Your Zhumell portable reflector comes preassembled in the box. All you have to do is install the red dot finder and you're ready to observe.

(The Z130 model also has an eyepiece tray, which installs in seconds.)

### Z114

#### INSTALLING THE RED DOT FINDER

1. Remove the thumb nuts from the optical tube assembly.
2. Place the finder over the threaded rods on the tube.
3. Reinstall the thumb nuts.
4. Remove the clear plastic battery cover on the finder.



#### Z114 TUBE ORIENTATION

The Z114 has a tube clamp to allow the eyepiece to be positioned at the most comfortable viewing angle. To rotate the tube, loosen the tube clamp screw on the tube clamp slightly, then rotate the optical tube so the eyepiece is positioned around a 45° angle from the ground. This can be adjusted to best suit your preference. Make sure the optical tube is forward enough in the tube rings so that you can point the telescope straight overhead without bumping into the base.

### Z130

#### INSTALLING THE RED DOT FINDER

1. Insert the finder into the dovetail holder on the telescope.
2. Lock the finder in place by tightening the thumbscrew on the dovetail holder.
3. Remove the clear plastic battery cover on the finder.



#### EYEPIECE TRAY INSTALLATION

1. Using the Phillips head screwdriver, loosen the two black screws located on the side of the base. Do not remove the screws, just loosen them about 1 turn.
2. Place the eyepiece tray over the screws with the mounting holes facing downward.
3. Gently push the tray downward so the screws align with the narrow portion of the mounting holes.
4. Retighten the 2 screws. Do not overtighten; they should only be snug enough to hold the eyepiece tray.



# Z114, Z130 PORTABLE REFLECTOR TELESCOPE

## Z130 TUBE ORIENTATION

The Z130 has a dovetail rail and adjustable tube rings to allow the eyepiece to be positioned at the most comfortable viewing angle. To rotate the tube, loosen the tube ring clamp screws on the tube rings slightly, then rotate the optical tube so the eyepiece is positioned around a 45° angle from the ground. Make sure the optical tube is forward enough in the tube rings so that you can point the telescope straight overhead without bumping into the base.

## Z130 TUBE DISASSEMBLY

You can quickly remove the optical tube from the base for easy storage and transport. Simply loosen the black thumbscrew from the dovetail holder on the base and slide the optical tube off the rail.

## TELESCOPE BASICS

### USING 1.25" EYEPIECES

1. The 1.25" is the most commonly used eyepiece format. The measurement of 1.25 inches is the diameter of the eyepiece barrel.
2. The eyepiece holder and focuser come already attached to the optical tube, next to where the finderscope is mounted.
3. Remove the plastic dust cover from the eyepiece holder.
4. Loosen the silver thumbscrew on the focuser drawtube.
5. Take out your 1.25" eyepiece. Remove the plastic covers.
6. Slide the chrome end of the eyepiece into the eyepiece holder.
7. Tighten the bottom thumbscrew to hold eyepiece in place.
8. View through the eyepiece and focus as needed. (See focusing section.)
9. To remove the eyepiece, loosen the silver thumbscrew.
10. To remove, loosen the thumbscrew and pull the eyepiece out of the focuser.
11. Use the plastic dust covers to protect the eyepiece and focuser during storage.



## ALTITUDE AND AZIMUTH

1. Your Zhumell portable reflector is adjustable along two axes - altitude (up/down) and azimuth (left/right). You can adjust the telescope's position along one or both axes at the same time.
2. Gently take hold of the end of the optical tube and move it either left or right (it will spin about its central azimuth bolt) or up and down.
3. The telescope can be positioned to view anywhere in the night sky, but be sure to let it move naturally; never force your telescope to move.
4. To tighten the altitude motion, simply tighten the large altitude tension knob located on the base. You can adjust the tension so that the telescope holds its position but still easily moves by hand.

## FOCUSING THE IMAGE

1. Insert the 1.25" eyepiece into the focuser.
2. Find a bright star and center it in the eyepiece. When the image is out of focus, the star looks like a doughnut. If focusing during the day, find an easily recognizable object like a sign or streetlight.
3. Turn the focus knobs until the star focuses to a point of light. Bright stars will sometimes show a plus-shaped flare (called diffraction spikes) coming from the secondary mirror support at the front of the telescope.
4. Changing eyepieces typically requires readjusting the focus.



# Z114, Z130 PORTABLE REFLECTOR TELESCOPE

## ALIGNING YOUR RED DOT FINDER

You need to align your finderscope so you can easily find objects in the sky. The finder must be pointing at the same object as the optical tube. Follow these steps to properly set up and align your red dot finder.

1. Insert the lowest-power eyepiece into the focuser. Focus the eyepiece to view an easily recognizable, stationary distant object like a sign, license plate, or streetlight.
2. Turn on the red dot by turning the knob clockwise all the way until it stops. This is the brightest setting. The setting can be dimmed when viewing objects at night.
3. Adjust the up/down and left/right knobs on the finder until the red dot is centered over the same object that is in your eyepiece. Be careful not to move the telescope during this process.

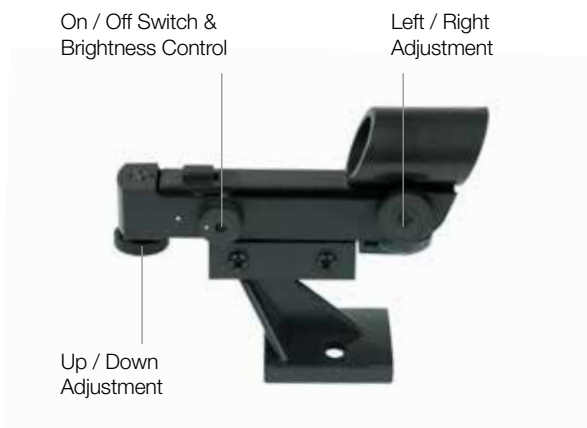

**NOTE:** Make sure you switch off the red dot finder when you are done using it to save the battery!

## OPTICAL ALIGNMENT (COLLIMATION)

You should occasionally check and adjust the optical alignment of your telescope. This procedure is called collimation, and is recommended for optimum telescope performance. To check the alignment of your telescope:

1. Remove the dust covers for the objective and focuser and look into the focuser drawtube.
2. Point the telescope at a lit wall indoors and look into the focuser drawtube. You should see the secondary mirror and a reflected image of the primary mirror.
3. Center your eye in the drawtube. You can reference the center mark on the primary mirror shown in the figure. The reflected image of the primary and secondary mirrors should be centered to one another, with your eye at the very center of the view, see figure. If the reflections do not look aligned, some adjustment will be needed.

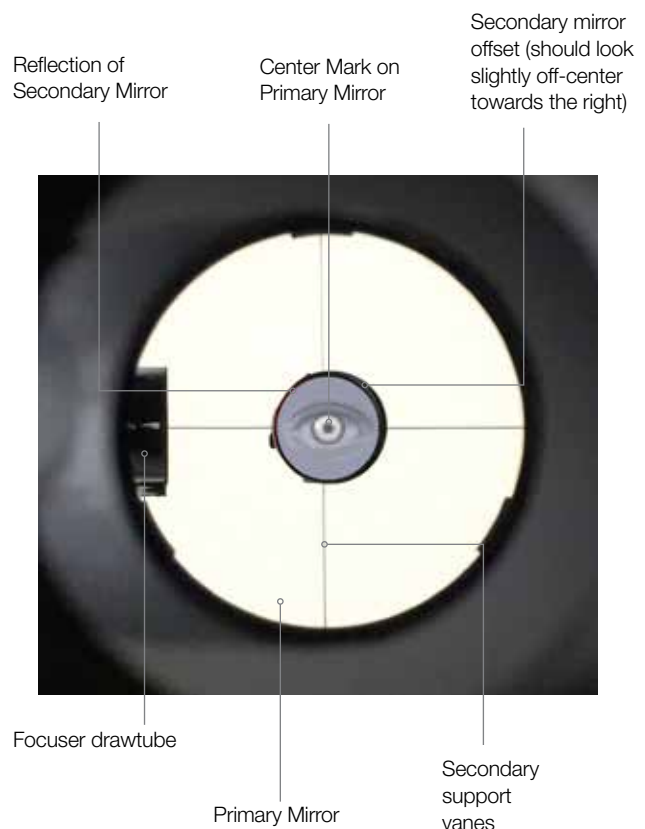



# Z114, Z130 PORTABLE REFLECTOR TELESCOPE

## ADJUSTING THE COLLIMATION

This is a quick reference to collimating your Zhumell Portable Reflector. We recommend using a collimation eyepiece (sold separately) for best results, but this procedure is fast and effective without a collimation eyepiece.

Tools required:

- Phillips head screwdriver
- 2 mm Allen wrench
- 2.5 mm Allen wrench (for Z130 only)

### A) SECONDARY MIRROR ADJUSTMENT

**If the center mark on the primary mirror does not appear to be in the center of your view:**

Using a 2 mm Allen wrench, make small adjustments to the three socket head screws to change the tilt of the secondary mirror so that the primary mirror center mark is in the center of the view.



**Do not adjust the center Phillips head screw.** This holds the secondary mirror onto the telescope! This can be adjusted with care of the secondary mirror is rotated, but we do not recommend making this adjustment. Consult a telescope expert to learn more about additional collimation methods.

### B) PRIMARY MIRROR ADJUSTMENT

**If the reflection of the secondary mirror does not appear to be in the center of your view:**

#### Z114

1. Loosen the 3 primary mirror lock screws a couple of turns each.
2. Turn the 3 primary mirror adjustment screws until the reflection of the secondary mirror is centered in the view.
3. Gently tighten the locking screws. Your telescope is now collimated.



#### Z130

1. Using a Phillips head screwdriver, remove the cover plate at the back of the telescope.
2. Using a 2.5mm Allen wrench, loosen the 3 primary mirror locking screws a couple of turns each.
3. Using the Phillips head screwdriver again, turn the 3 primary mirror adjustment screws until the reflection of the secondary mirror is centered in the view.
4. Gently tighten the locking screws and reinstall the cover plate. Your telescope is now collimated.



## OBSERVATION TIPS FOR YOUR TELESCOPE

### SELECTING A VIEWING SITE

The ideal site for using your telescope is in the middle of nowhere. Most users don't have access to the darkest of skies, however, so select a site that is both far from light pollution and practical for travel. Avoid street lights, yard lighting, rooftops, and chimneys, and never observe through an open window indoors. Be sure your site is out-of-town or very dark and has clear view of a large portion of the sky.

### DARK ADAPTING YOUR EYES

When you go out into the dark, your eyes need time to adjust. You will initially be able to see only a fraction of the stars and objects your eyes are capable of. Remain in the dark (don't look at any lights or cell phones) for at least 30 minutes, and your eyes should be around 80% of their full dark-adapted sensitivity. Every time bright light comes into your eye, the dark-adapting process will start over.

When eyes are fully dark-adapted, you will probably still need to see what you're doing. Use a red-light flashlight to maneuver around the area. A regular flashlight covered in red cellophane will work, but red LED lights are best.

### SEEING AND TRANSPARENCY

Atmospheric conditions are of the utmost importance when considering viewing conditions for your astronomical binoculars. These conditions are commonly referred to as "seeing." When seeing is good, star twinkling is minimal and objects appear steady in your lenses. Seeing is best overhead, worst at the horizon, and generally better after midnight. You can't see the stars without looking through the atmosphere, so the clearer the air and the higher your altitude, the better seeing conditions you will encounter.

### DARK ADAPTING YOUR EYES

When you go out into the dark, your eyes need time to adjust. You will initially be able to see only a fraction of the stars and objects your eyes are capable of. Remain in the dark (don't look at any lights or cell phones) for at least 30 minutes, and your eyes should be around 80% of their full dark-adapted sensitivity. Every time bright light comes into your eye, the dark-adapting process will start over.

When eyes are fully dark-adapted, you will probably still need to see what you're doing. Use a red-light flashlight to maneuver around the area. A regular flashlight covered in red cellophane will work, but red LED lights are best.

## TRACKING CELESTIAL OBJECTS

The Earth is always rotating about its polar axis, completing one full rotation every 24 hours. This is what defines our "day", and we see it in the apparent movement of sun and stars throughout each rotation. In the same way that the sun rises and sets each day, the stars in the sky rise and set each night. The motion translates to a rate of approximately  $.25^\circ$  per minute, or 15 arc-seconds per second. This is commonly referred to as the sidereal rate.

As you observe any celestial object, remember that it is in motion. You will need to continuously update your telescope's position throughout a viewing session, which is where your telescope's fine altitude and azimuth adjustments become useful. As an object begins to leave your field of view, gently nudge the OTA in the correct direction and bring it back to center.

Remember, the higher the magnification at which you're viewing, the smaller your field of view. Objects will appear to move faster as you raise magnification, and more frequent positional adjustments will need to be made.

## SELECTING AND EYEPIECE

By using eyepieces of different focal lengths, many different magnifications can be achieved with your Zhumell telescope. The best place to start is with the included 9mm and 32mm Plossl eyepieces for higher and lower magnifications, respectively. Many astronomers own a large number of eyepieces in order to customize their equipment based on the object being viewed. To calculate the magnification of a telescope/eyepiece combination, divide the focal length of the telescope by the focal length of the eyepiece.

No matter which eyepiece you intend to use, always start by using the lowest-power (longest focal length) eyepiece to locate and center the object. Lower magnification means a wider field of view, making it easier to find an object and justify your scope in its direction.

Once you've centered the desired object using your lowest-power eyepiece, go ahead and make the switch to a higher magnification. Make further centering adjustments, and continue to work up if desired. Higher magnifications are useful for small and bright objects like planets and double stars. Viewing the Moon with increased magnification also yields great results.

Deep-sky objects, however, typically look best at medium and low magnifications. This is because they tend to be faint, yet have apparent width. Deep-sky

# Z114, Z130 PORTABLE REFLECTOR TELESCOPE

objects often fall from view at higher magnifications, since the image becomes dimmer. This is not an unbreakable rule, since many galaxies are bright enough for high magnification, but works as a decent rule-of-thumb.

Regardless of the object, or what recommendations are made, the best way to become familiar with proper viewing magnifications is to experiment. Always start with low magnification and wide field-of-view and work your way up. If the view continues to improve, continue increasing power. If the image begins to degrade, back off the magnification and use a lower-power eyepiece.

## THE MOON

The Moon is one of the easiest and most rewarding targets at which to point your telescope. Its rocky, cratered surface is close enough to be rendered in some detail, and allows for satisfying exploration. The best time for lunar viewing is during its partial phases, when shadows fall on the craters and canyon walls to give them definition. Even though the full moon may look like a tempting target, the light is too bright and the definition too low for optimal viewing.

When viewed through a telescope, even a partial-phase moon is very, very bright. Using a Moon filter helps to dim the glare - these and other filters simply thread underneath the bottom of the telescope eyepiece.

## THE STARS

Through your telescope, stars will appear much as they do to the naked eye - as tiny points of light against a dark sky. Even powerful telescopes cannot magnify stars to appear as anything more than these pinpoint. You can, however, enjoy the different colors of their glow and locate many beautiful double- and multiple-stars. Two popular targets are the "Double-Double" in the constellation Lyra and the two-color double star Albireo in Cygnus.

## THE PLANETS

The planets are beautiful and popular targets for astronomers, but they can be more difficult to keep track of than the stars or moon. Planetary position charts can readily be found online or in any astronomical publication. Sun and Moon aside, the brightest objects in the night sky are Venus, Mars, Jupiter, and Saturn. With practice, you will be able to render these in some detail. Generally, the apparent size of planets is quite small, and higher-power eyepieces are recommended for best results.

## JUPITER

Jupiter is our solar system's largest planet. Through your scope, you can easily see the planet and observe the changing positions of its four largest moons: Io, Callisto, Europa, and Ganymede. With higher-magnification eyepieces, you will be able to see cloud bands wrapped around the planet and the famous Great Red Spot.

## SATURN

This infamously ringed planet can be a fantastic sight through your scope. The tilt-angle of the rings varies over a period of many years, so they may be seen edge-on (like a thin line) or broadside (like giant "ears" on each side of the planet). You will need a good steady atmosphere to achieve a worthwhile view of Saturn. If you look closely enough, you can see the Cassini division - a thin, dark gap in the rings. You can also often make out one or more of Saturn's moons, including the largest - Titan.

## VENUS

At its brightest, Venus is the most luminous of all the planets - so bright that it is occasionally visible in full daylight. Venus appears as only a thin crescent at its brightest, and it is never found far from morning or evening horizon. No surface detail can be seen on Venus as it is surrounded by dense cloud cover.

## MARS

Mars makes a close approach to our planet once every two years, which is the best time to observe it. With your telescope, you'll be able to see a salmon-colored disk marked with dark patches and possible a whitish polar ice cap. Surface detail on Mars is only observable during prime conditions with a high-power eyepiece.

## DEEP-SKY OBJECTS

With dark skies, ideal viewing conditions, and a large telescope like your Zhumell Dobsonian, you can observe a huge number of amazing objects outside our solar system - commonly referred to as "deep-sky objects". These include star clusters, galaxies, gaseous nebulas, and more. Your Dobsonian is well-equipped to gather the light necessary to view these objects, but you will need to find a viewing site well away from light pollution and give your eyes plenty of time to fully dark-adapt. As you continue to view, your eyes will become trained, and more and more subtle details from these objects will become apparent. Don't expect to see color, however, as human eyes are not sensitive enough to distinguish color from faint light.

# Z114, Z130 PORTABLE REFLECTOR TELESCOPE

## ASTRONOMY FORMULAS

### MAGNIFICATION

To determine the magnification of a telescope and eyepiece combination, divide the telescope focal length by the eyepiece focal length.

$$\text{Magnification (x)} = \frac{\text{Telescope Focal Length (mm)}}{\text{Eyepiece Focal Length (mm)}}$$

Ex: 17mm Eyepiece with a 114x450mm telescope.  
Magnification = 450/17mm

$$\text{Magnification} = 26.47x$$

### FOCAL RATIO

To determine the focal ratio of a telescope, divide the focal length of the telescope by the aperture.

$$\text{Focal Ratio (f/x)} = \frac{\text{Telescope Focal Length (mm)}}{\text{Aperture (mm)}}$$

Ex: Focal Ratio of a 114x450mm telescope.

$$\text{Focal Ratio (f/x)} = 450/114\text{mm}$$

$$\text{Focal Ratio (f/x)} = f/3.95$$

## ASTRONOMY TERMINOLOGY

### DECLINATION (DEC.)

The astronomical equivalent of latitude. Declination describes the angle of a celestial object above or below the celestial equator. The sky over the Northern hemisphere has a positive declination. The sky over the Southern hemisphere has a negative declination. For example, Polaris (the North Star) which lies nearly directly over the North Pole, has a declination value of 90°.

### RIGHT ASCENSION (R.A.)

The astronomical equivalent of longitude. Right Ascension measures the degree of distance of a star to the east of where the ecliptic crosses the celestial equator. R.A. is measured in hours, minutes, and seconds as opposed to degrees. It is different than the term "meridian", which is used in referring to lines of longitude. Right Ascension is referred to in "hour circles". There are 24 hour circles of right ascension which run from the north to the south celestial poles.

### CELESTIAL EQUATOR

The celestial equator is the line of declination which lies directly above the Earth's equator. The celestial equator lies halfway between the north and south celestial poles and serves as the 0° point in measuring declination.

### ECLIPTIC

The ecliptic is the apparent path of the sun through the sky over the course of the year. Since we view the sun from different angles throughout the year, it appears to move in relation to other stars. The vernal (spring) and autumnal (fall) equinoxes lie at the points where the ecliptic intersects the celestial equator. The vernal equinox is where right ascension is at 0h (hours). The autumnal equinox can be found at 12h R.A.

### ZENITH

The zenith is the point in the celestial sphere directly above your head. The zenith varies depending upon your location. In general, the declination point of your zenith is equal to the latitude at which you are standing on Earth.

### EPHEMERIS

The ephemeris of a planet or the sun or the moon is a table giving the coordinates of the object at regular intervals of time. The coordinates will be listed using declination and right ascension. Other information such as distance and magnitude may be listed in ephemerides (plural of ephemeris).

### ALTITUDE

The altitude of a celestial object is the angular distance of that object above the horizon. The maximum possible altitude is the altitude of an object at the zenith, 90°. The altitude of an object on the horizon is 0°. Altitude is measured from your point of observation and does not directly correlate to points on the celestial sphere.

### AZIMUTH

Azimuth is the angular distance around the horizon measured eastward in degrees from the North Horizon Point. Thus, the North Horizon Point lies at an azimuth of 0°, while the East Horizon Point lies at 90°, and the South Horizon Point at 180°. Azimuth is measured from the point of observation and does not directly correspond to points on the celestial sphere.

### ANGULAR DISTANCE

Angular distance is the size of the angle through which a telescope tube or binocular aiming at one object must be turned in order to aim at another object. If you must rotate the equipment from the zenith to the horizon, the angular distance between the two points would be 90°.

# Z114, Z130 PORTABLE REFLECTOR TELESCOPE

## TELESCOPE TERMINOLOGY

### OBJECTIVE

The objective is the front lens of a telescope. The listed measurement for objective lenses is the lens diameter. A larger objective allows more light to enter a telescope and provides a brighter image. The objective diameter is also sometimes referred to as the aperture of a telescope.

### FOCAL LENGTH

The focal length of a telescope is the distance from the point where light enters a telescope (the objective) to the point where the image is in focus. In telescopes with the same size objective, a longer focal length will provide higher magnification and a smaller field of view.

### MAGNIFICATION

The magnification of a telescope is determined by the relationship between the focal length of the telescope and the focal length of the eyepiece used. A greater difference in these focal lengths results in a greater the magnification of the telescope. Every telescope has a maximum useful magnification of about 60 times the diameter of the objective in inches. Magnification beyond the maximum useful magnification will provide dim, low contrast images.

### FOCAL RATIO

The focal ratio of a telescope is a description of the relationship between the focal length and objective lens size of a telescope.

Visually, a smaller focal ratio (also called f-stop) provides a wider field of view. Photographically, the lower the f-stop, the shorter the exposure time needed to capture an object on film.

### LIMITING MAGNITUDE

The limiting magnitude of a telescope describes the faintest object you can see with a telescope. The magnitude of a star describes its brightness. The larger the magnitude of an object, the fainter it appears to be. The brightest stars have a magnitude of 0 or less.

### RESOLVING POWER

The resolving power, or Dawes' Limit, of a telescope is the ability to view closely spaced objects through a telescope. The resolving power of a telescope is measured in seconds of arc. The smaller the resolving power, the better you will be able to separate binary stars when viewing through your telescope.

### ABERRATION

Aberrations are degradations in image, which can occur due to optical system design or improper alignment of optical system components. The most common types of aberration are chromatic aberration, spherical aberration, coma, astigmatism, and field curvature.

### COLLIMATION

Collimation is the alignment of optical components within an optical system. Improper collimation will distort an image and may result in aberrations present in the image. Most reflector telescopes have collimation adjustments which can be made in order to reduce aberrations and image distortion. Refractor telescopes do not require collimation nearly as often as reflector telescopes.



FCC NOTE: This equipment has been tested and found to comply with the limits for a Class B digital device, pursuant to part 15 of the FCC Rules. These limits are designed to provide reasonable protection against harmful interference in a residential installation. This equipment generates, uses, and can radiate radio frequency energy and, if not installed and used in accordance with the instructions, may cause harmful interference to radio communications. However, there is no guarantee that interference will not occur in a particular installation. If this equipment does cause harmful interference to radio or television reception, which can be determined by turning the equipment off and on, the user is encouraged to try to correct the interference by one or more of the following measures:

- Reorient or relocate the receiving antenna.
- Increase the separation between the equipment and receiver.
- Connect the equipment into an outlet on a circuit different from that to which the receiver is connected.
- Consult the dealer or an experienced radio/TV technician for help.

Product design and specifications are subject to change without prior notification.  
This product is designed and intended for use by those 14 years of age and older.