

CRAZYFOIL

ASSEMBLY GUIDE

ACROBATIC



STANDARD



EASY

KITE / WAKE / SURF

WARNINGS

SECURITY & IMPORTANT NOTICES

STANDARD CONFIGURATION

IN YOUR BOX **P.1**

THE MAST **P.2**

THE FOILS **P.3**

FRONT FOIL & FUSELAGE **P.4**

MAST & FUSELAGE **P.5**

REAR FOIL & FUSELAGE **P.7**

FIN & FUSELAGE **P.8**

OPTIONS

FROM STANDARD TO EASY **P.11**

FROM EASY TO STANDARD **P.19**

FROM ACROBATIC TO GLIDER **P.30**

BOARD FIXING

ANY BOARD **P.32**

BAREFOOT/STRAPS BOARDS **P.41**

SUMMARY

WARNINGS

Product involving inherent risks of injury or death. Sharp edges and corners may be very dangerous while manipulating and using. It is highly recommended to take lessons and/or professional advice before starting to use.

- This product should not be used by small children and is reserved to experienced riders.
- Always wear a helmet and a properly fitted life jacket approved by your country's agency.
- Consult your physician prior to use.
- Read the Warnings and follow the right Assembly Guide to assemble and use your hydrofoil properly before starting to foil.
- Check your equipment prior to use for signs of wear or failure.
- Manufacturer, distributor, reseller and affiliates shall not be held liable for any injury or death arising from the use of a Crazy Foil product.
- Always use boards with proper bindings or straps maintaining feet firmly to the board. The barefoot practice increases significantly the risks of injury or death. Reserved to very experienced foil riders.
- Failure to use an appropriate leash while practicing barefoot may lead to injury or death to you and others.
- Never ride alone, always be accompanied by a person able to call emergencies in case of incident.
- Use with surveillance; keep control at an appropriate speed for your ability level. The faster you ride, the greater the risk.
- Know that dock starts or use of man-made feature increases risks.
- Do not use in shallow waters or near shore, seaweeds, docks, pilings, swimmers, other watercrafts or any other obstacle.
- Use only on water with a qualified watercraft driver and observer.
- By purchasing a Crazy Foil product, you assume all responsibilities for its use and any resulting injury or death to you and others.

USE AT YOUR OWN RISK.

To upload our full Warnings & Precautions file, go to www.crazyfoil.com/warnings-precautions/

IMPORTANT NOTICE

STRENGTH OF THE SCREWS

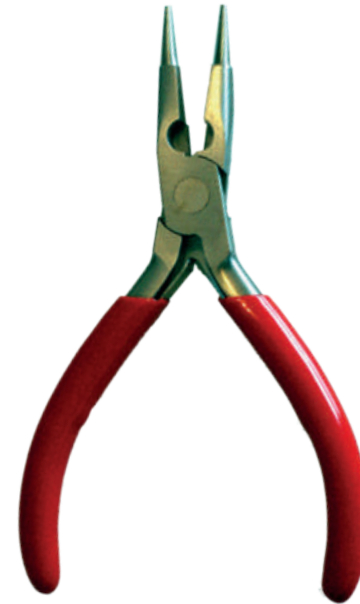

*ALL SCREWS NEED TO BE TIGHTEN WITH THE ALLEN KEY AT HAND-FORCE FIRST.
WHEN THE MAXIMUM IS REACHED, TAKE CLAMPS AND SCREW BY A QUARTER TO A HALF TURN MORE.*

IMPORTANT NOTICE

SPECIAL CARE

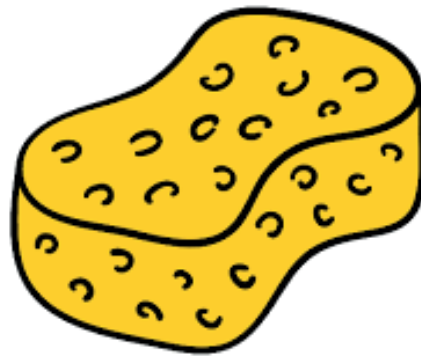

DISMENTAL YOUR FOIL ON A REGULAR BASIS TO WASH ALL THE PARTS SEPARATELY WITH UNSALTED WATER. FOR A SPECIAL CARE,, USE AN ANTI-SEIZE GREASE ON BOLTS.

IMPORTANT NOTICE

SOFT FOAM BOARDS



**IF USING A BOARD MADE OF SOFT FOAM INSIDE (EXTRUDED POLYSTYREN, EPS)
TAKE SPECIAL CARE TO FIX THE HYDROFOIL.**

USE A MOUNTING SYSTEM



**SEAL YOUR BOARD WEN USING
CRAZY FOIL SANDWICH SYSTEM**



IN YOUR BOX

PARTS



Foil 16"/40cm



Foil 22"/56cm



Fuselage



Mast 26"/66cm

OR



Mast 34"/86cm

FOILS KIT

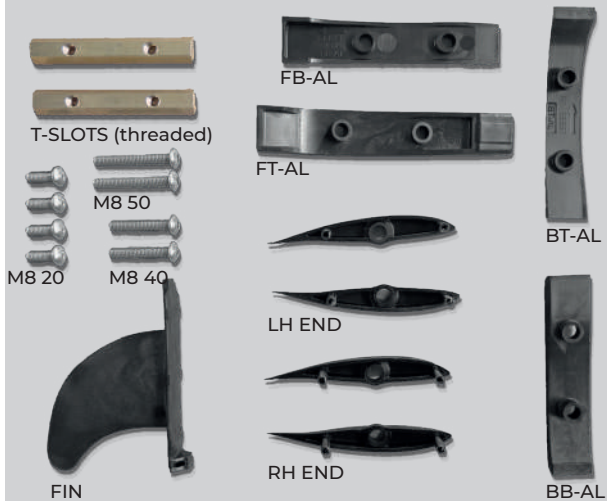

FUSELAGE KIT

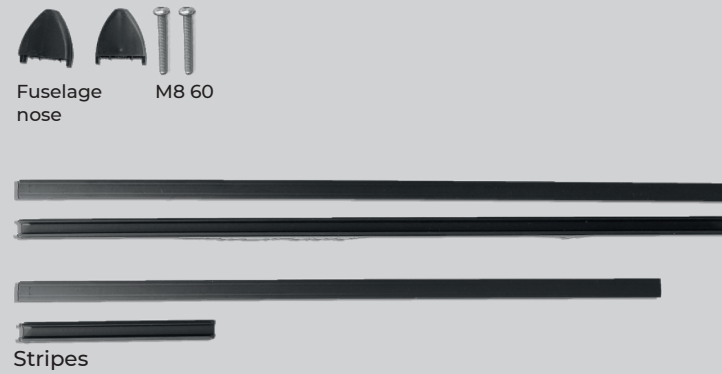

MAST KIT

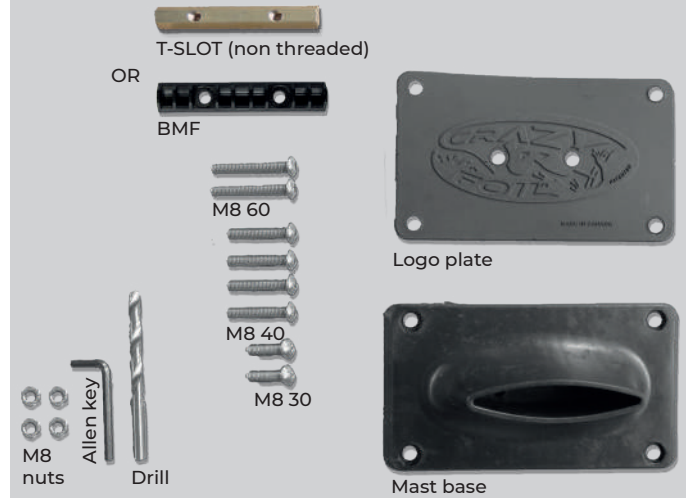



STANDARD

STANDARD CONFIGURATION

THE MAST

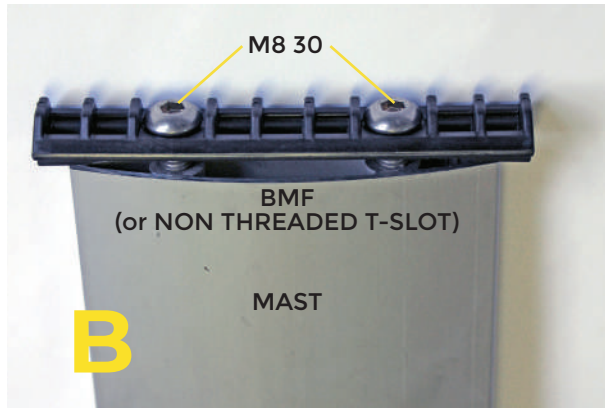

IF USING TRACK SYSTEM

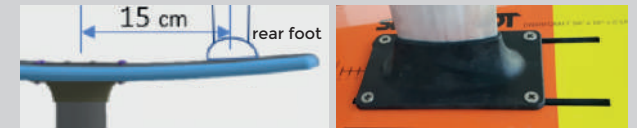

IF USING SANDWICH SYSTEM

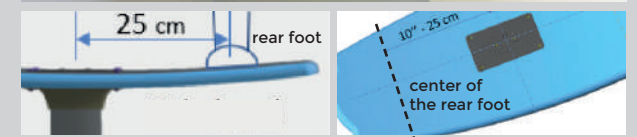
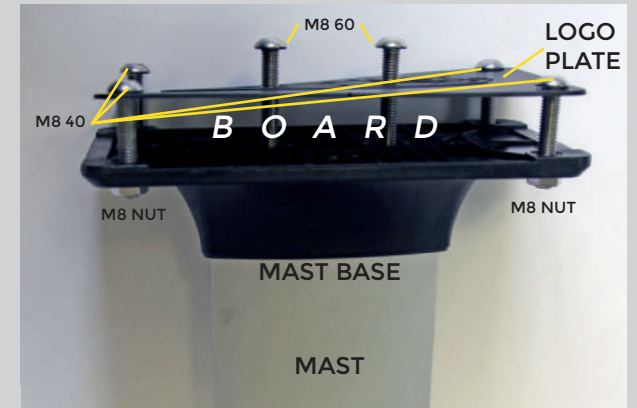

STANDARD CONFIGURATION

THE FOILS

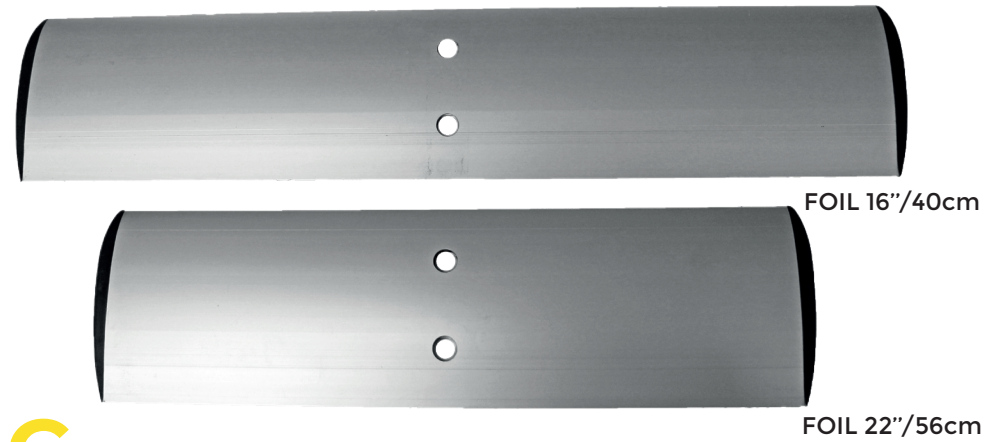
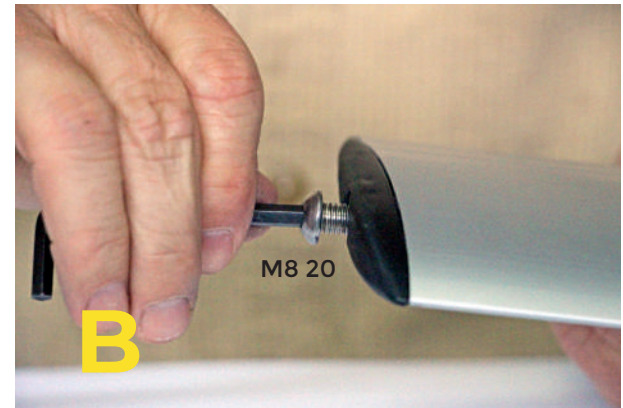
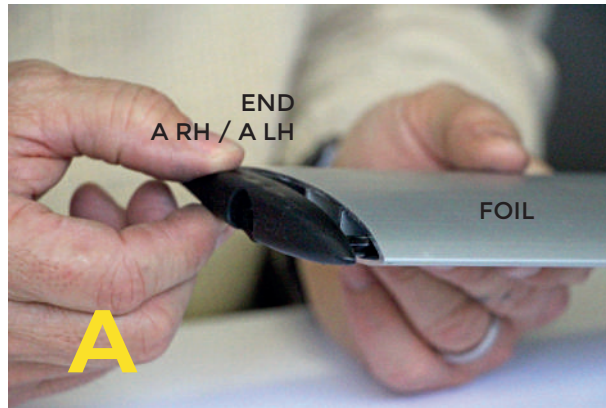

DO IT FOR BOTH FOILS

2.

STANDARD CONFIGURATION FRONT FOIL & FUSELAGE

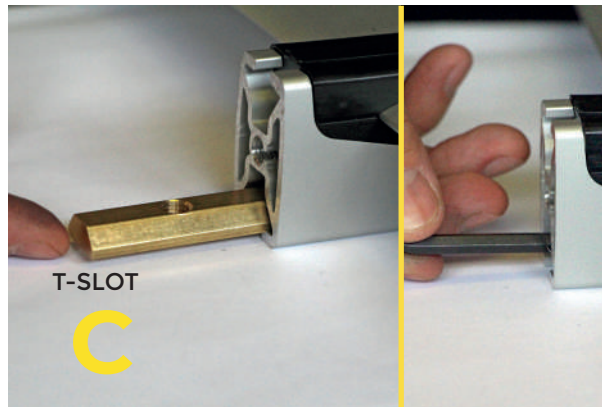
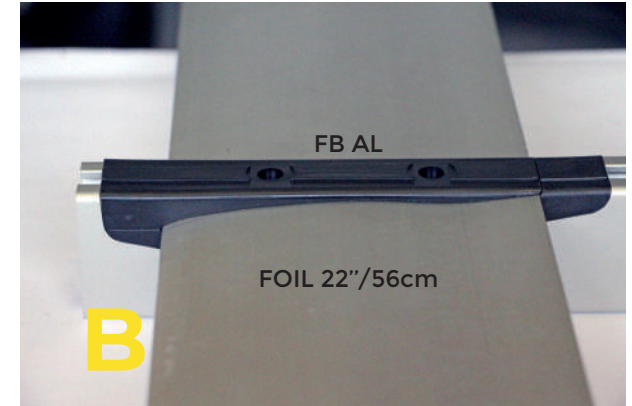
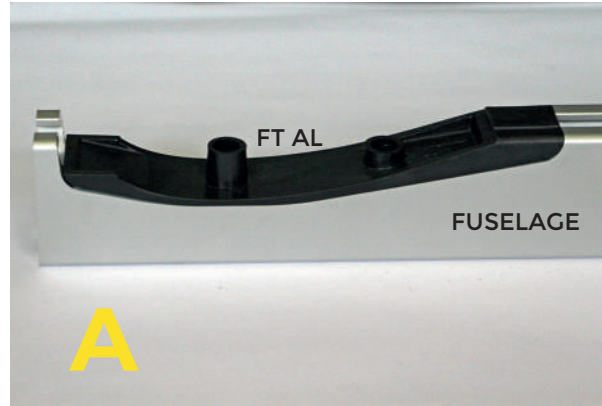

PUSH WITH ALLEN KEY

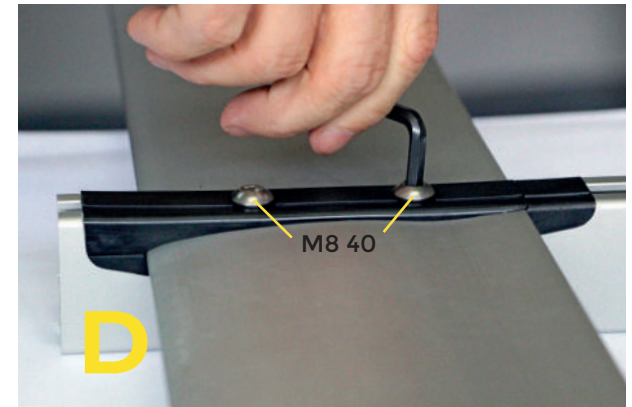

3.

STANDARD CONFIGURATION

MAST & FUSELAGE

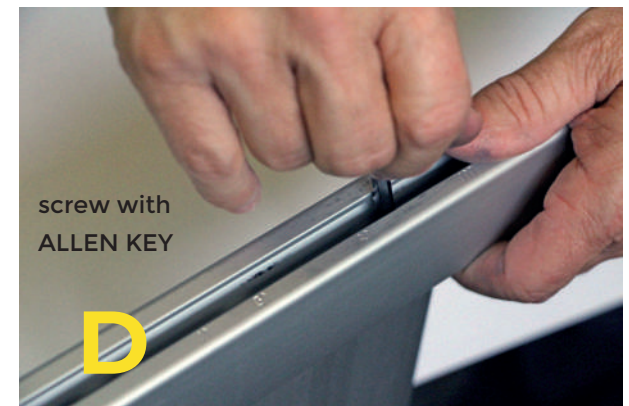
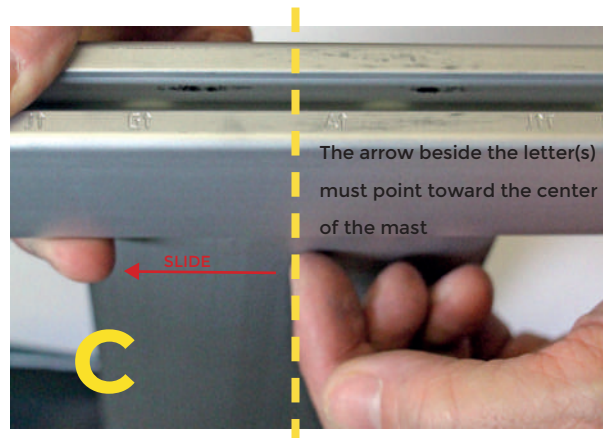
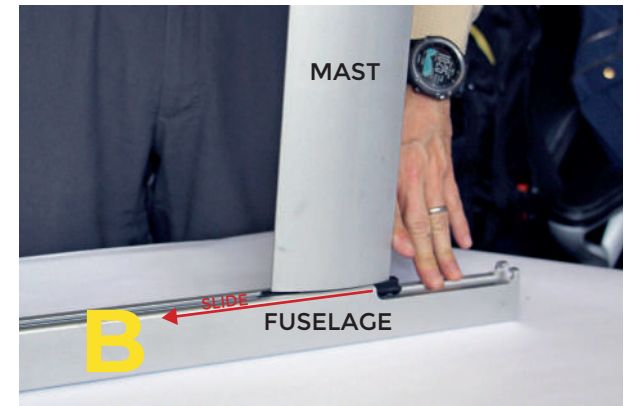

4.

STANDARD CONFIGURATION

MAST CONFIGURATION

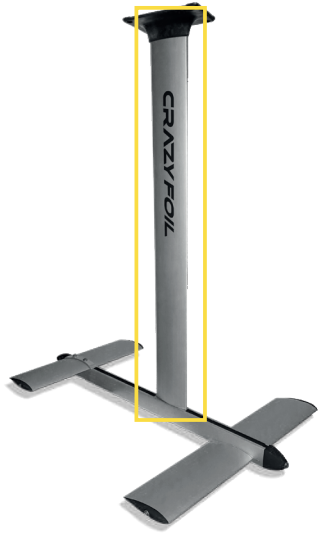

ACROBATIC
USING SANDWICH SYSTEM

ACROBATIC
USING TRACK SYSTEM

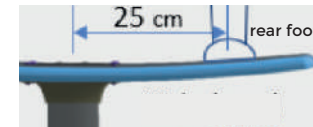
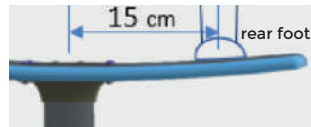

Position of the fuselage is good only if you position the mast on the board at 25 cm with sandwich installation and 15 cm with track system.

If you cannot respect these measurements for any reason, compensate by sliding the mast into the fuselage of the corresponding measurement difference.

Example:

if the mast center on the board is 5 cm closer to the middle of the rear foot, move the mast forward on the fuselage 5 cm towards the fin.

If the mast center on the board is 5 cm further to the middle of the rear foot, move the mast forward on the fuselage 5 cm towards the nose.

STANDARD CONFIGURATION

REAR FOIL & FUSELAGE

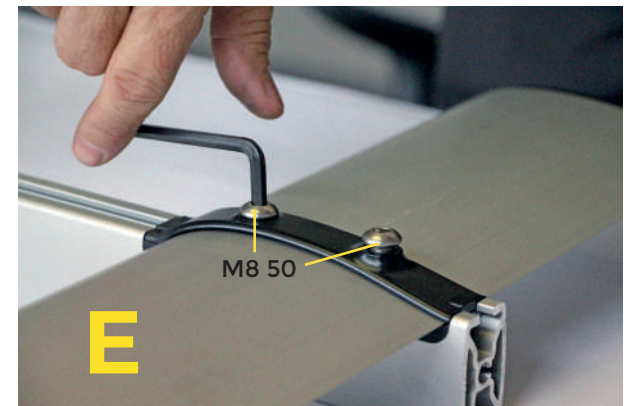
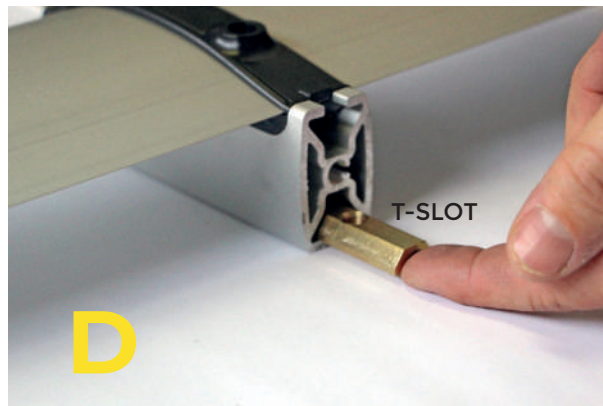
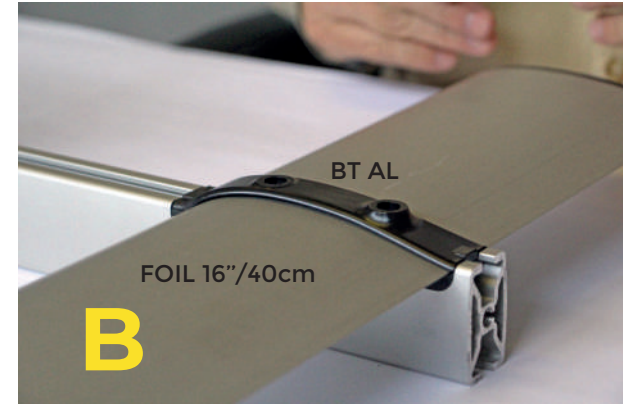
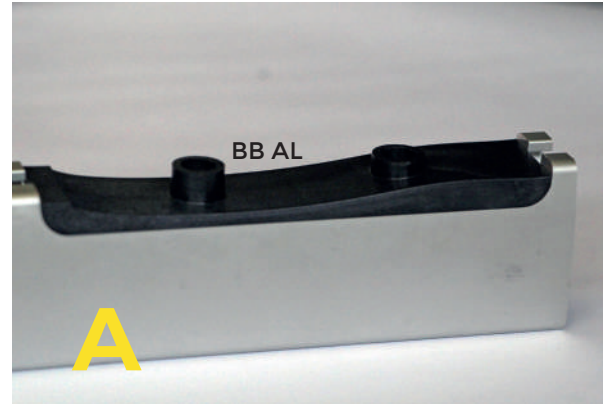

5.

STANDARD CONFIGURATION

FIN & FUSELAGE



A

IF USING THE FIN

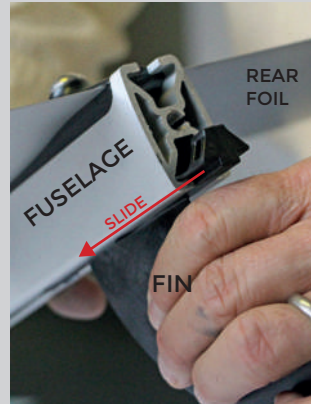

IF NOT USING THE FIN



A

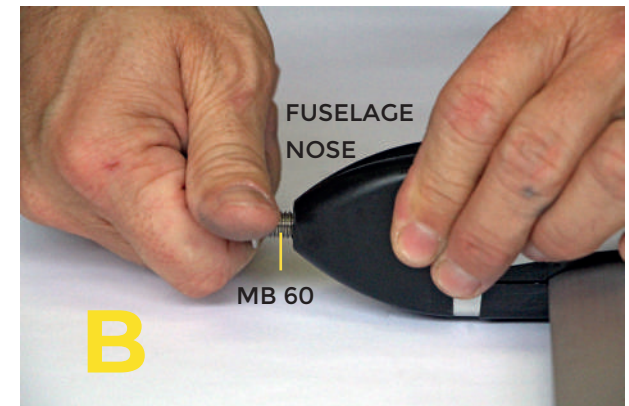

B

DO IT FOR BOTH EXTREMITIES

6.

OPTIONS

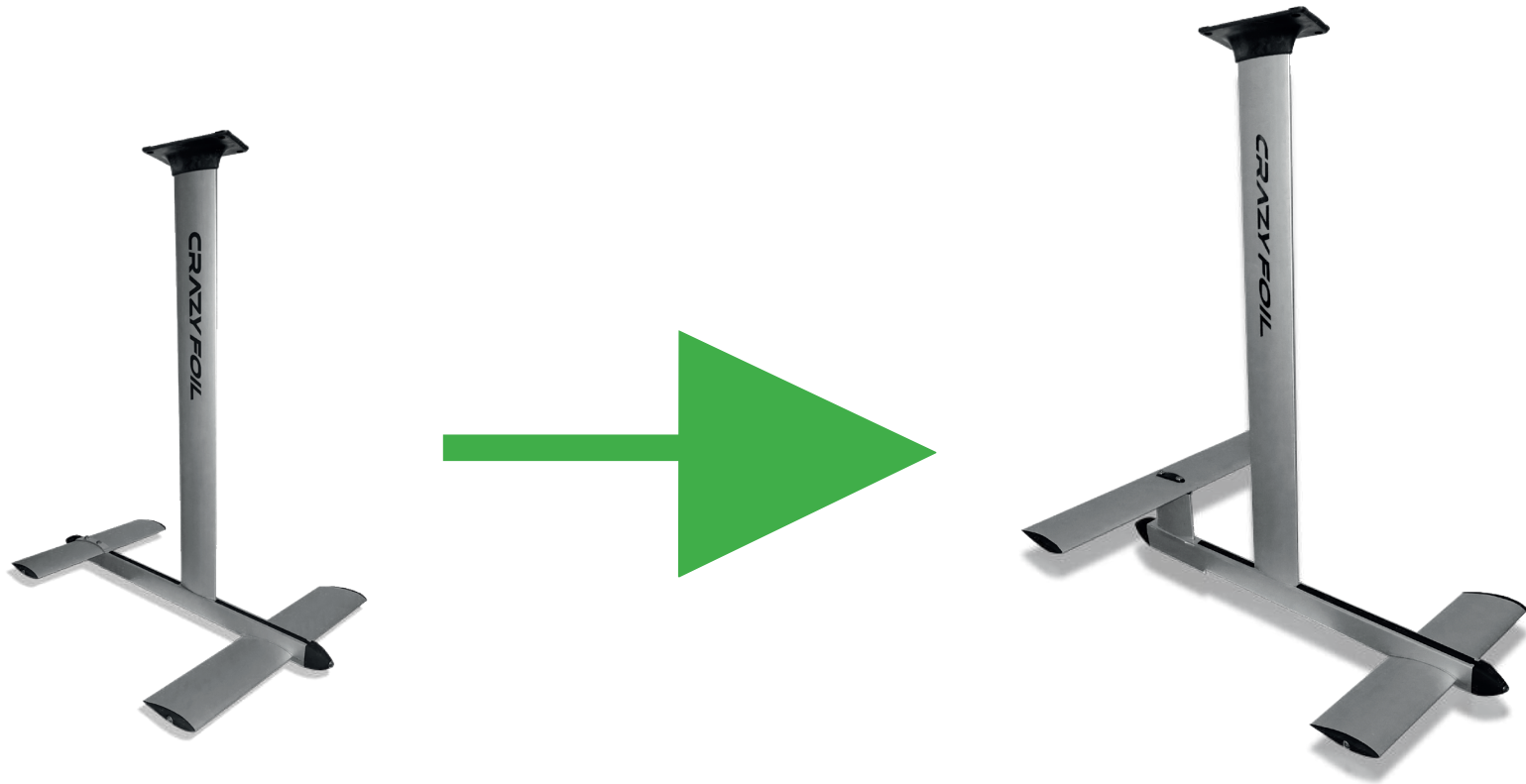

FROM STANDARD TO EASY

OVERVIEW EASY KIT

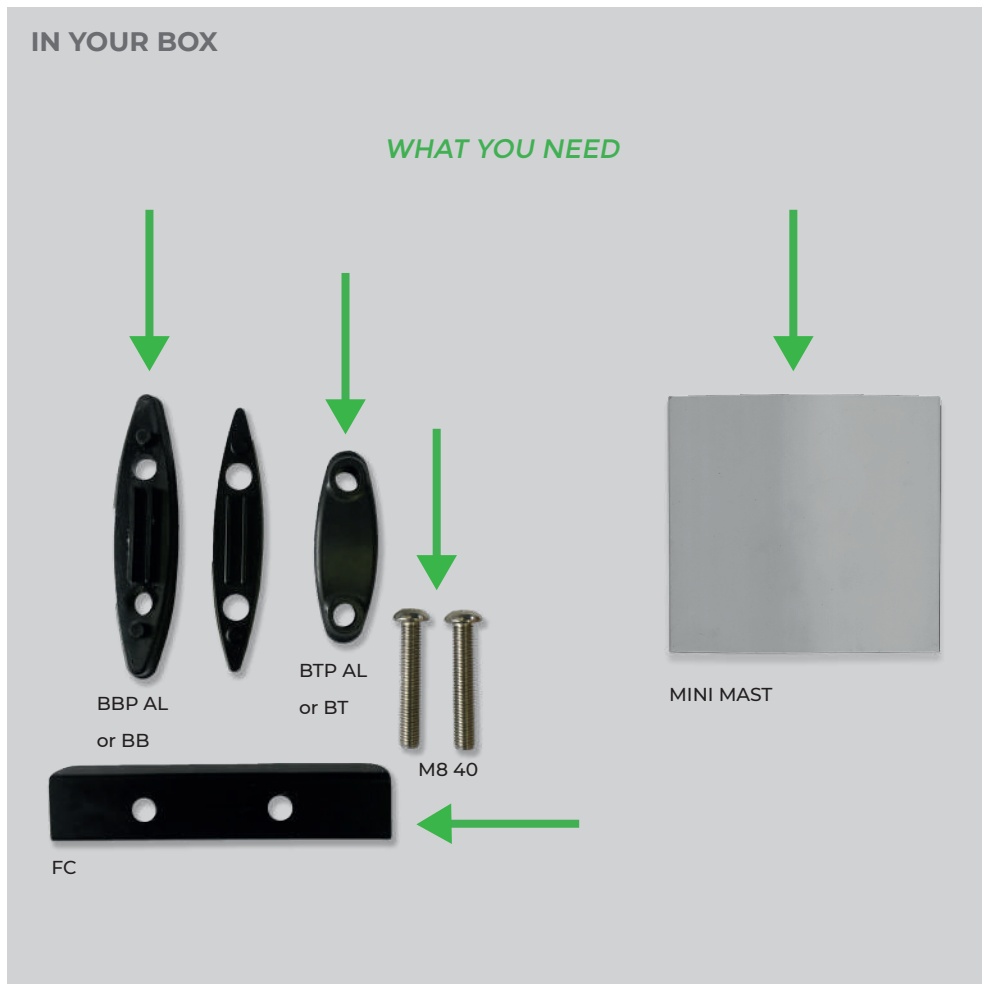

from STANDARD



to EASY

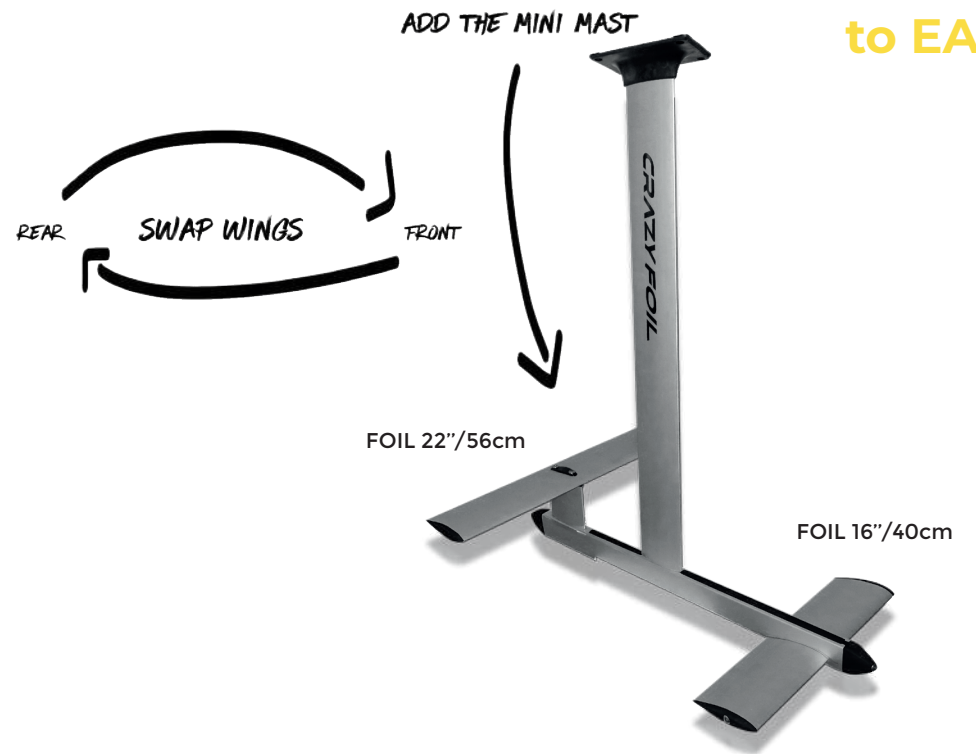

FROM STANDARD TO EASY

REMOVE FRONT FOIL

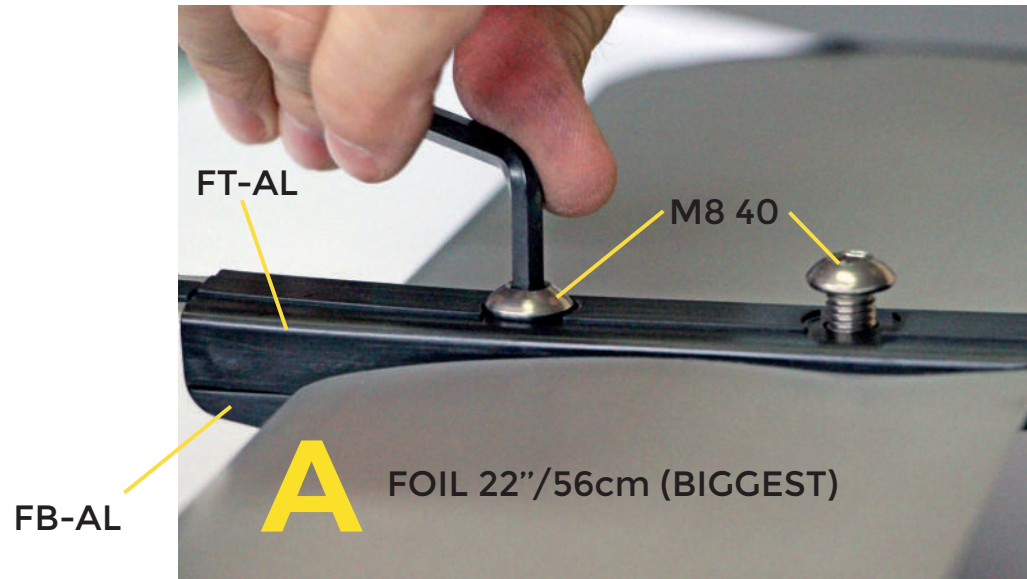

FB-AL

FT-AL

M8 40

A

FOIL 22"/56cm (BIGGEST)

REMOVE SCREWS, FT-AL,
FB-AL AND BIGGEST FOIL

1.

STANDARD CONFIGURATION

REMOVE REAR FOIL

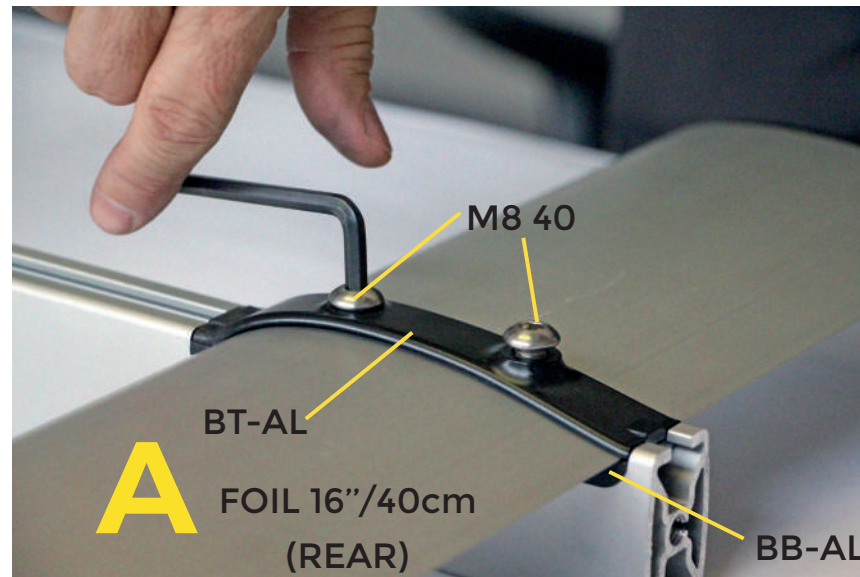

REMOVE SCREWS, BT-AL,
BB-AL AND SMALLEST FOIL

2.

FROM STANDARD TO EASY

MINI MAST UNDER REAR FOIL

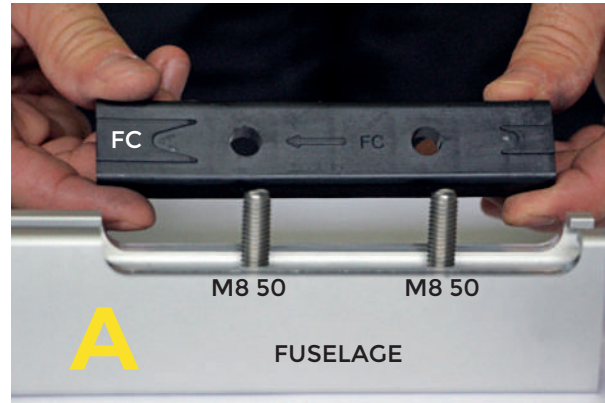

INSERT M8 50 SCREWS FROM THE BOTTOM OF THE FUSELAGE SO THEY POINT TOWARD THE SKY

THEN PLACE THE FC PART: THE ARROW MUST POINT TOWARD THE FRONT OF THE FUSELAGE

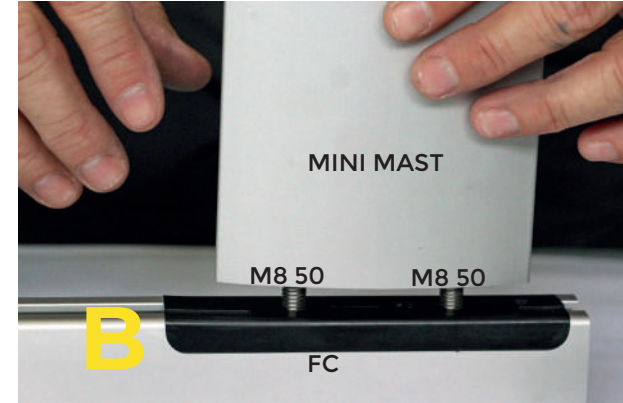

SCREW WITH ALLEN KEY



3.

FROM STANDARD TO EASY REAR FOIL

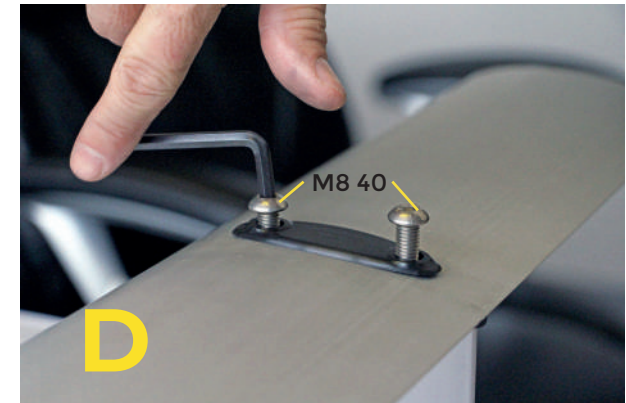
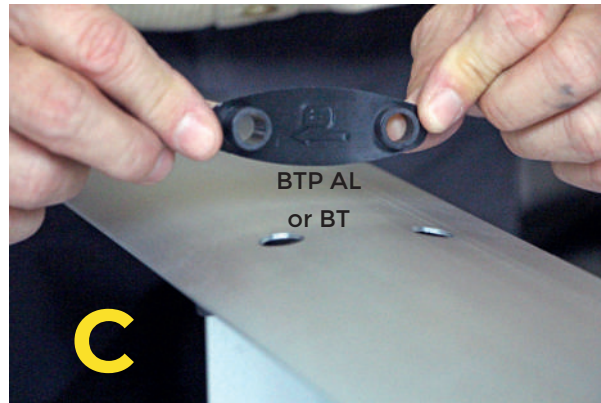
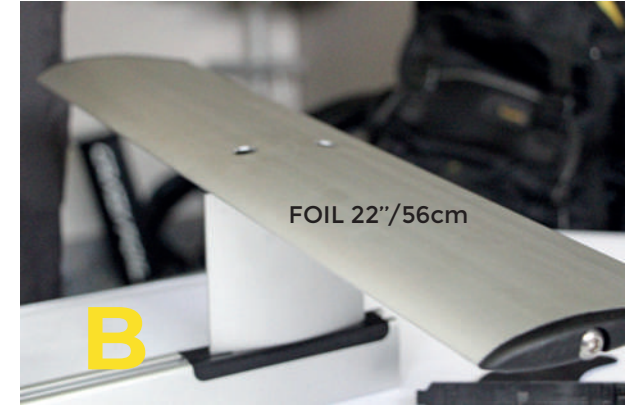
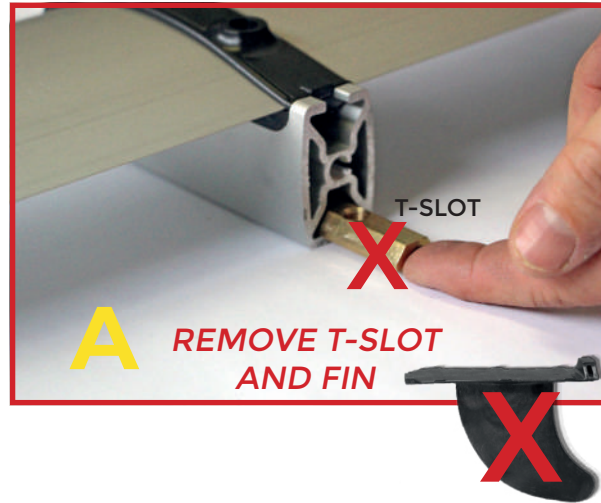

4.

FROM STANDARD TO EASY ADJUST MAST

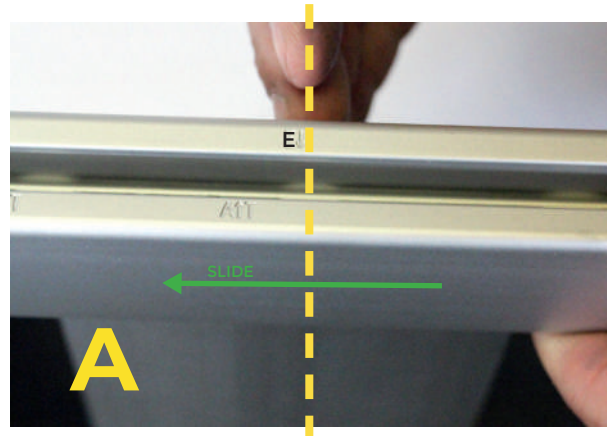

SLIDE UNTIL THE ARROW BESIDE «E» or «ET»
(if you are using a track system)
POINTS TOWARD THE CENTER OF THE MAST



SCREW WITH ALLEN KEY



ACROBATIC EASY
USING SANDWICH SYSTEM

ACROBATIC EASY
USING TRACK SYSTEM

5.

FROM STANDARD TO EASY FINISH FUSELAGE

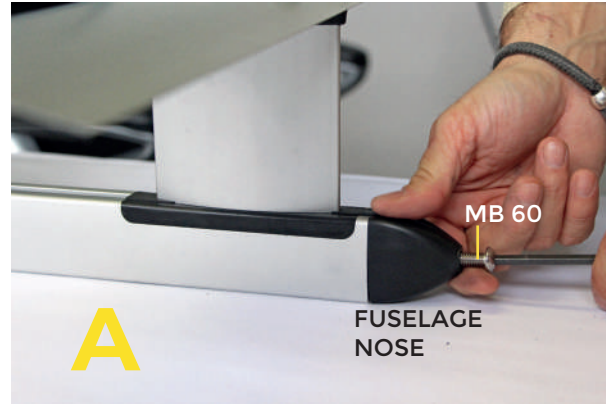

6.

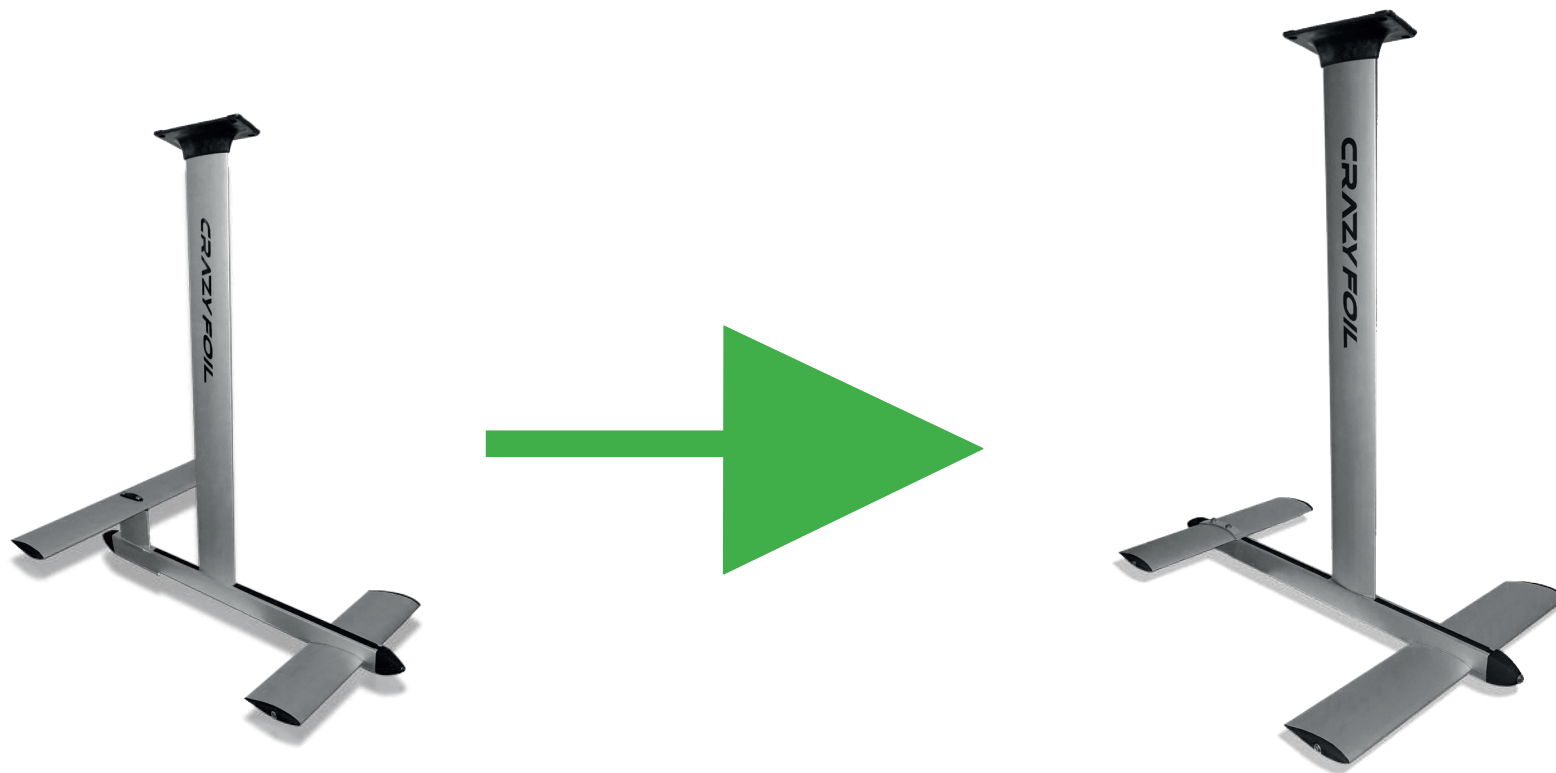

FROM EASY TO STANDARD

FROM EASY TO STANDARD FUSELAGE



REMOVE STRIPES

1.

FROM EASY TO STANDARD

REMOVE REAR FOIL



LOOSE BIGGEST FOIL
22"/56cm (REAR)



REMOVE BTP-AL OR BT



REMOVE THE FOIL

2.

FROM EASY TO STANDARD

MINI MAST



A
REMOVE BBP-AL



B
LOOSE MINI MAST

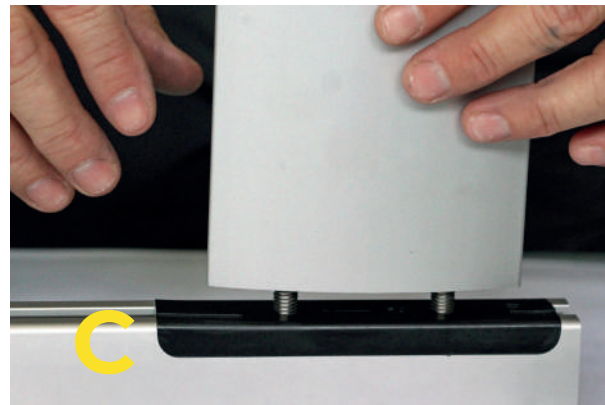

C
REMOVE MINI MAST

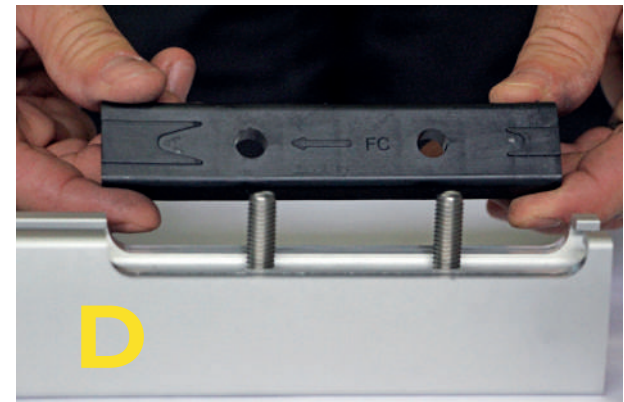

D
REMOVE FC PART
AND SCREWS

3.

FROM EASY TO STANDARD FUSELAGE NOSE

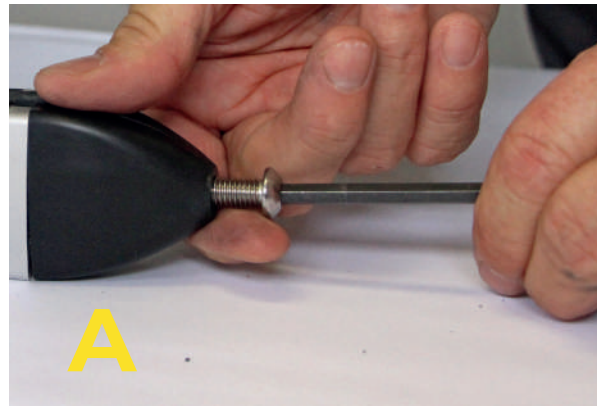

REMOVE REAR
FUSELAGE NOSE

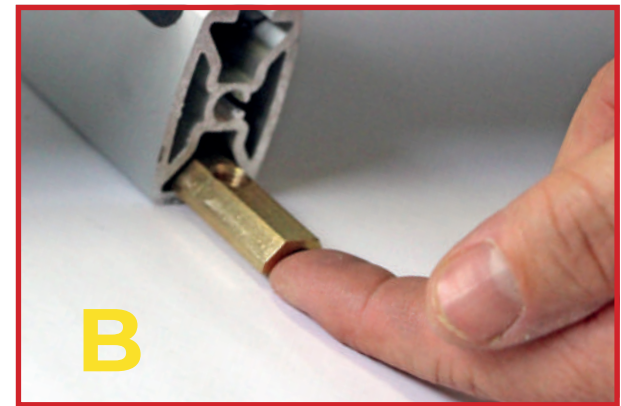

INSERT T-SLOT IN THE
LOWER PART OF THE
FUSELAGE

4.

FROM EASY TO STANDARD
REMOVE FRONT FOIL

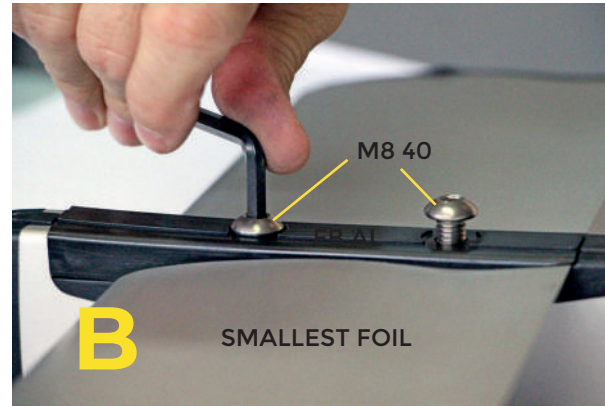

**LOOSE SMALLEST FOIL
16"/40cm (REAR)**

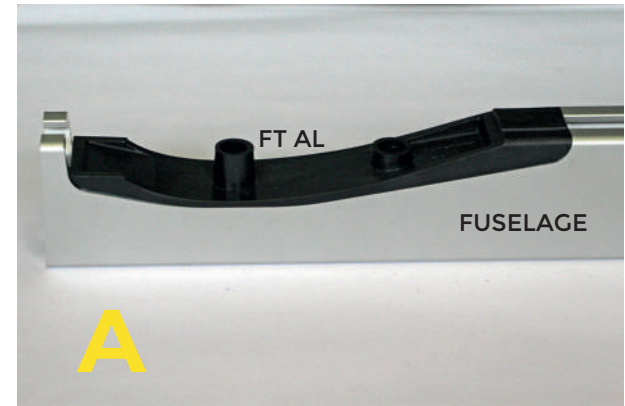

**REMOVE SMALLEST FOIL
16"/40cm (REAR)**

5.

FROM EASY TO STANDARD SCREW REAR FOIL



BB-AL

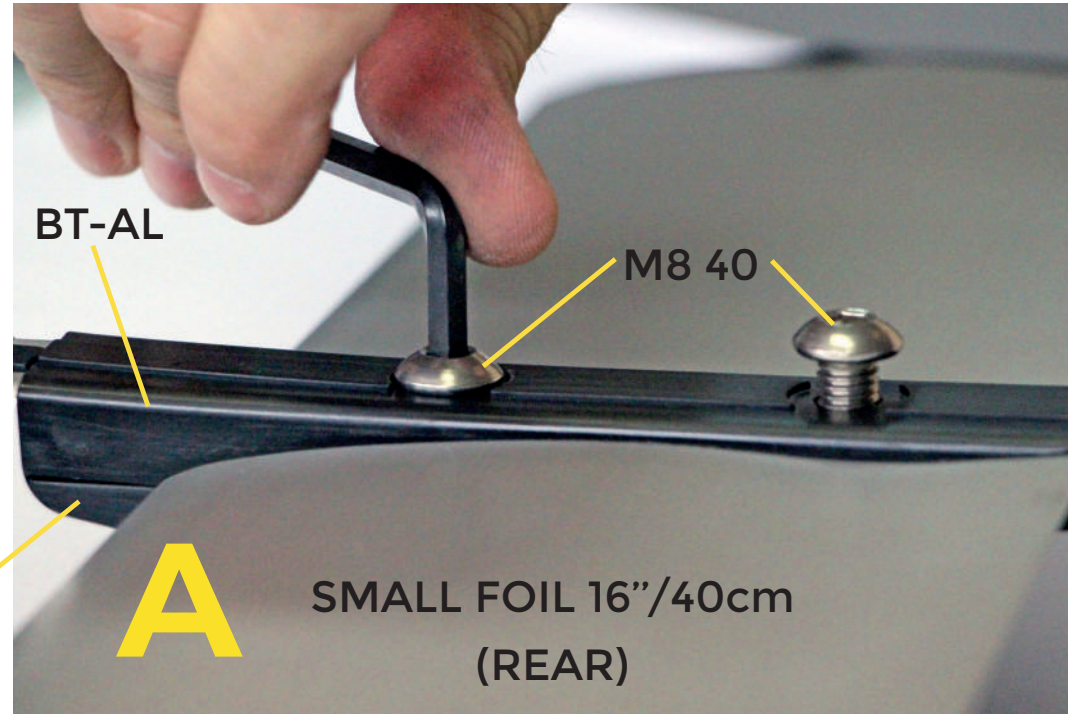

PLACE THE BB-AL PART ON FUSELAGE,
PLACE THE SMALLEST FOIL 16"/40cm UPON
IT AND THE BT-AL PART ON TOP OF THE FOIL.
SCREW EVERYTHING WITH M8 40.

***SCREWS MUST BE ALIGNED WITH THE T-SLOT
YOU ALREADY INSERT IN THE FUSELAGE.***

6.

FROM EASY TO STANDARD
REAR FUSELAGE NOSE

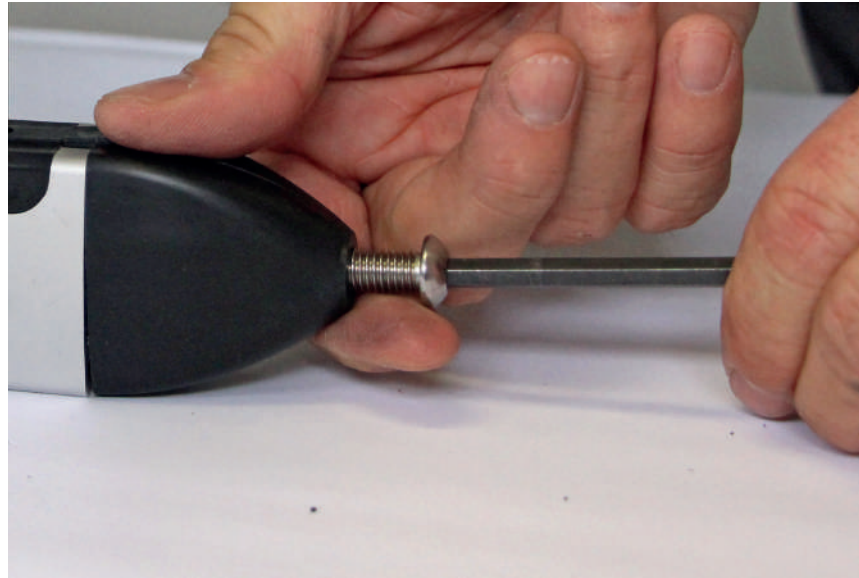

PUT FUSELAGE NOSE BACK
AND SCREW

7.

FROM EASY TO STANDARD

SCREW FRONT FOIL



8

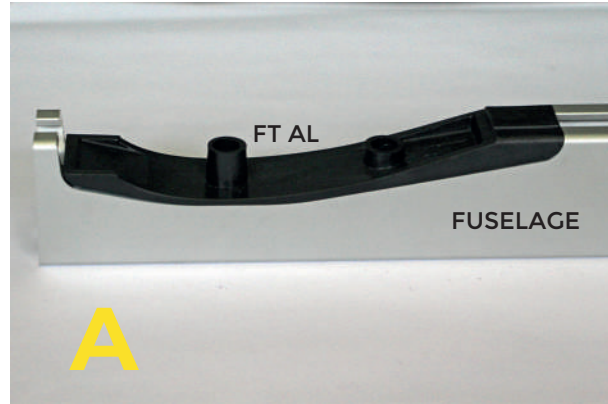

PLACE FT-AL ON
FUSELAGE

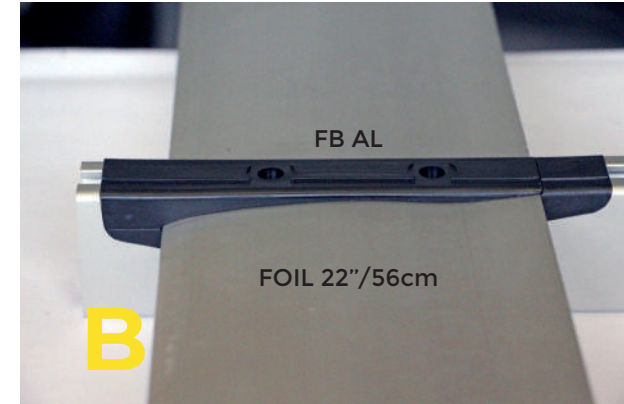

PLACE BIGGEST FOIL
22"/56cm on FUSELAGE
AND FB-AL ON TOP

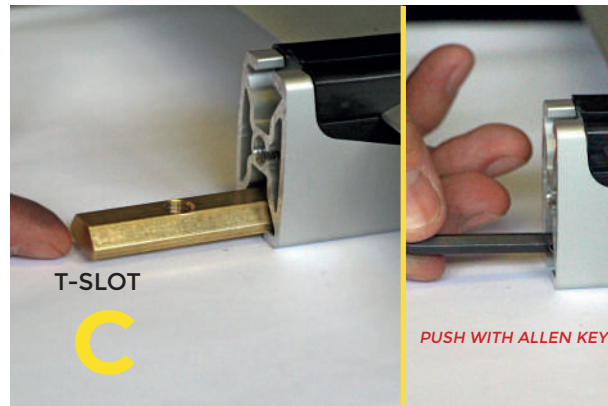

INSERT T-SLOT IN THE
BOTTOM PART OF THE
FUSELAGE

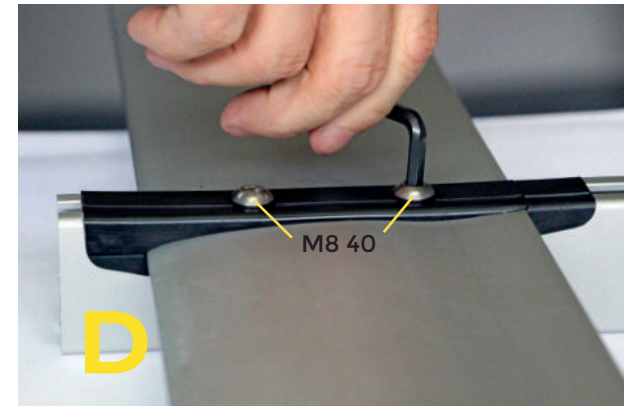

SCREW WITH M8 40.
**SCREWS MUST BE ALIGNED
WITH T-SLOT.**

FROM EASY TO STANDARD

FRONT FUSELAGE NOSE

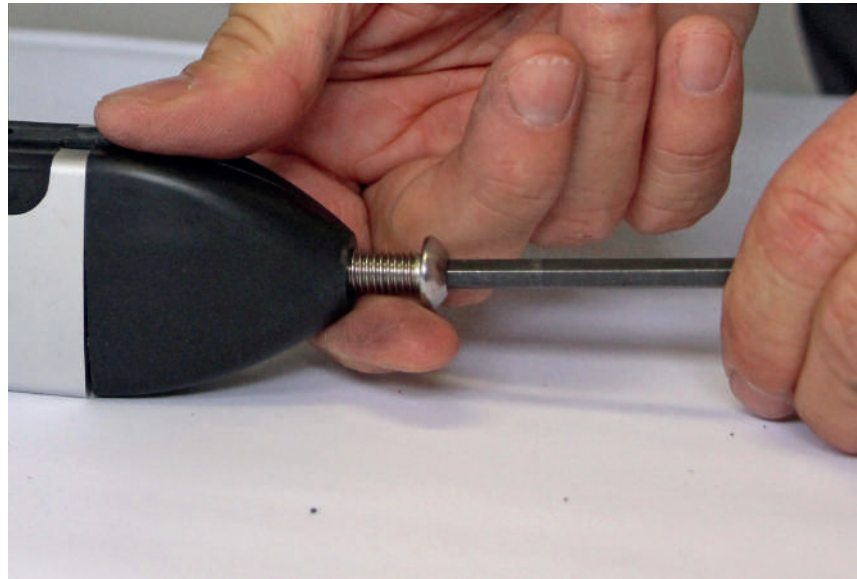

PUT FUSELAGE NOSE BACK
AND SCREW

9.

FROM EASY TO STANDARD
BACK TO STANDARD



LOOSE MAST FROM FUSELAGE
AND SLIDE IT TO THE STANDARD
POSITION (REFER TO PAGE 6)

10.

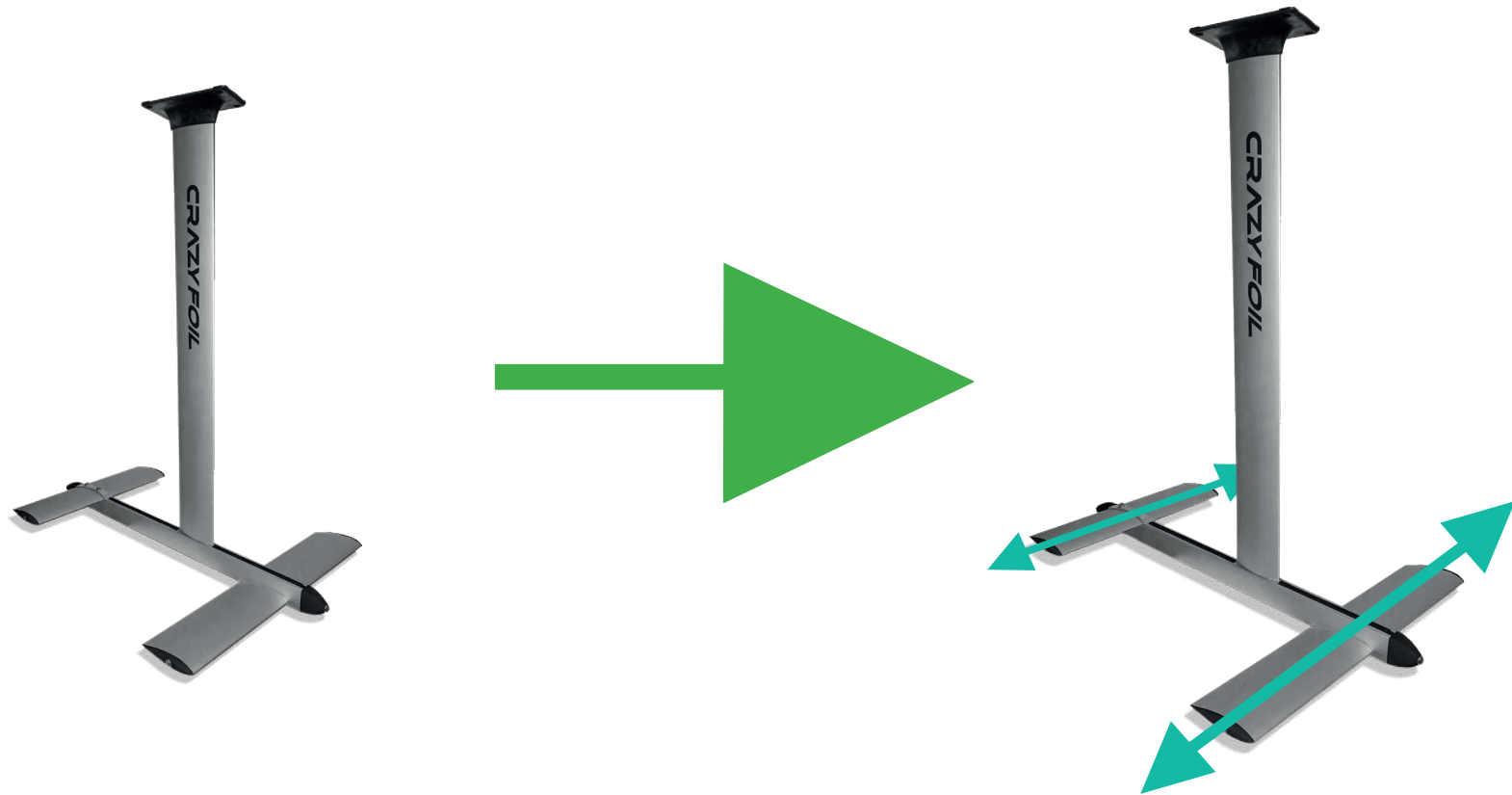

FROM ACROBATIC TO GLIDER

HOW TO TRANSFORM AN ACROBATIC INTO A GLIDER: CHANGE FOILS

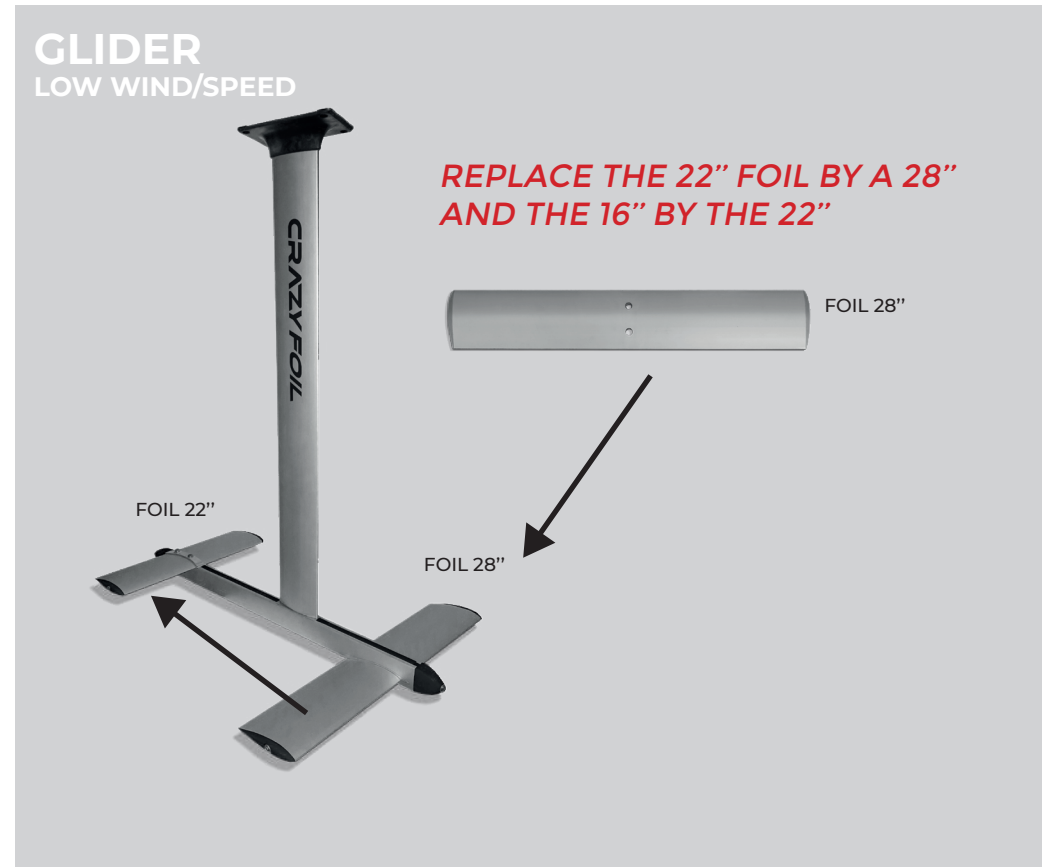
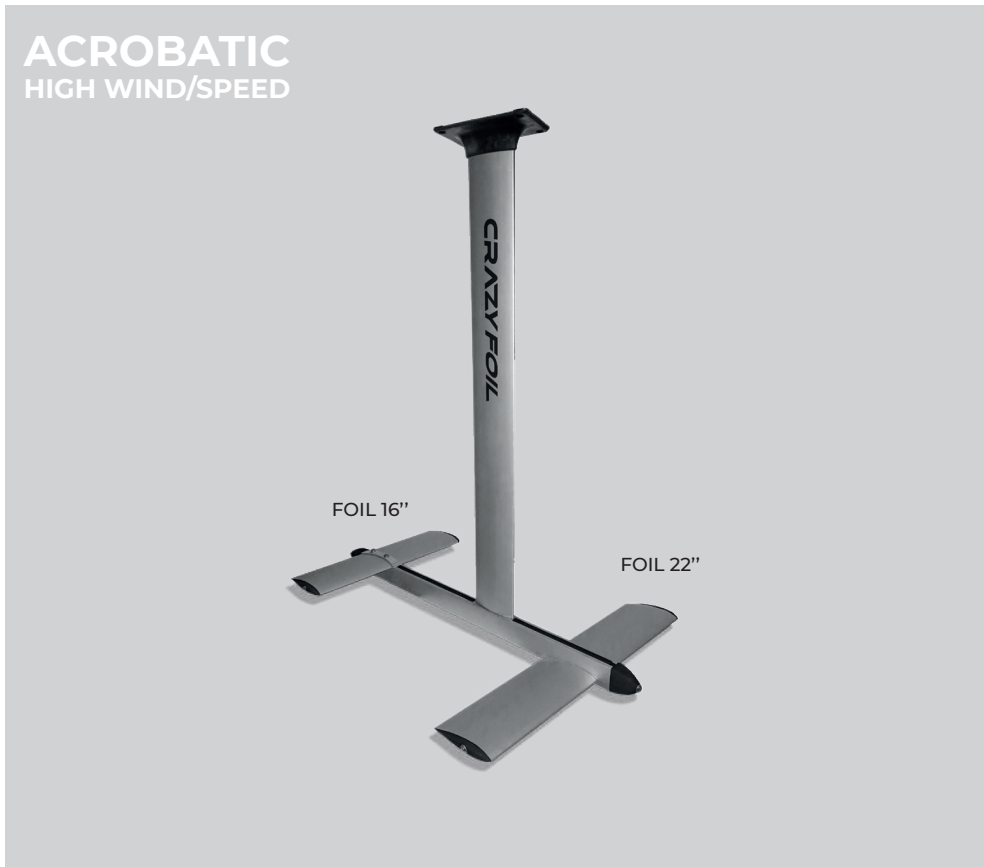

YOUR ACROBATIC BECOMES A GLIDER WHEN YOU CHANGE FOILS FOR BIGGER ONES.
WITH MORE LIFT, THE GLIDER WILL ALLOW YOU TO PRACTICE **WAKESURF**.

DON'T FORGET TO CHANGE YOUR MAST POSITION FROM «A» (OR «AT») TO «G» (OR «GT»)

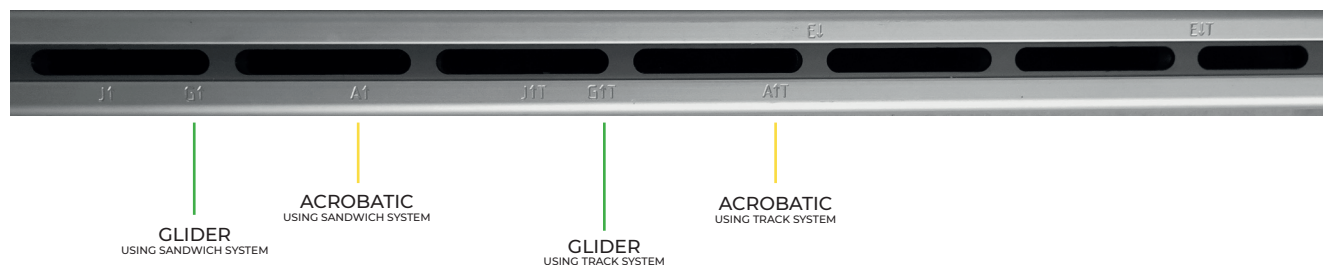

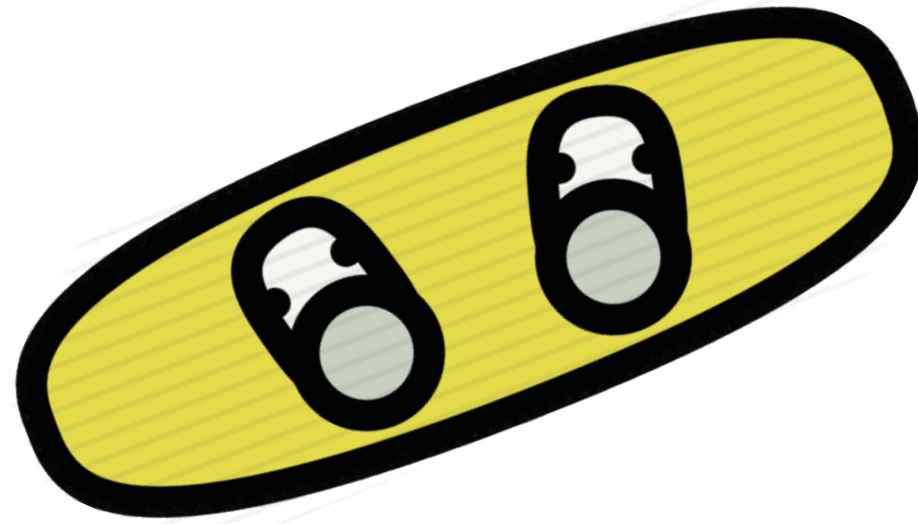

BOARD FIXING

BOOTS POSITIONING & BOARD FIXING

WHAT YOU NEED

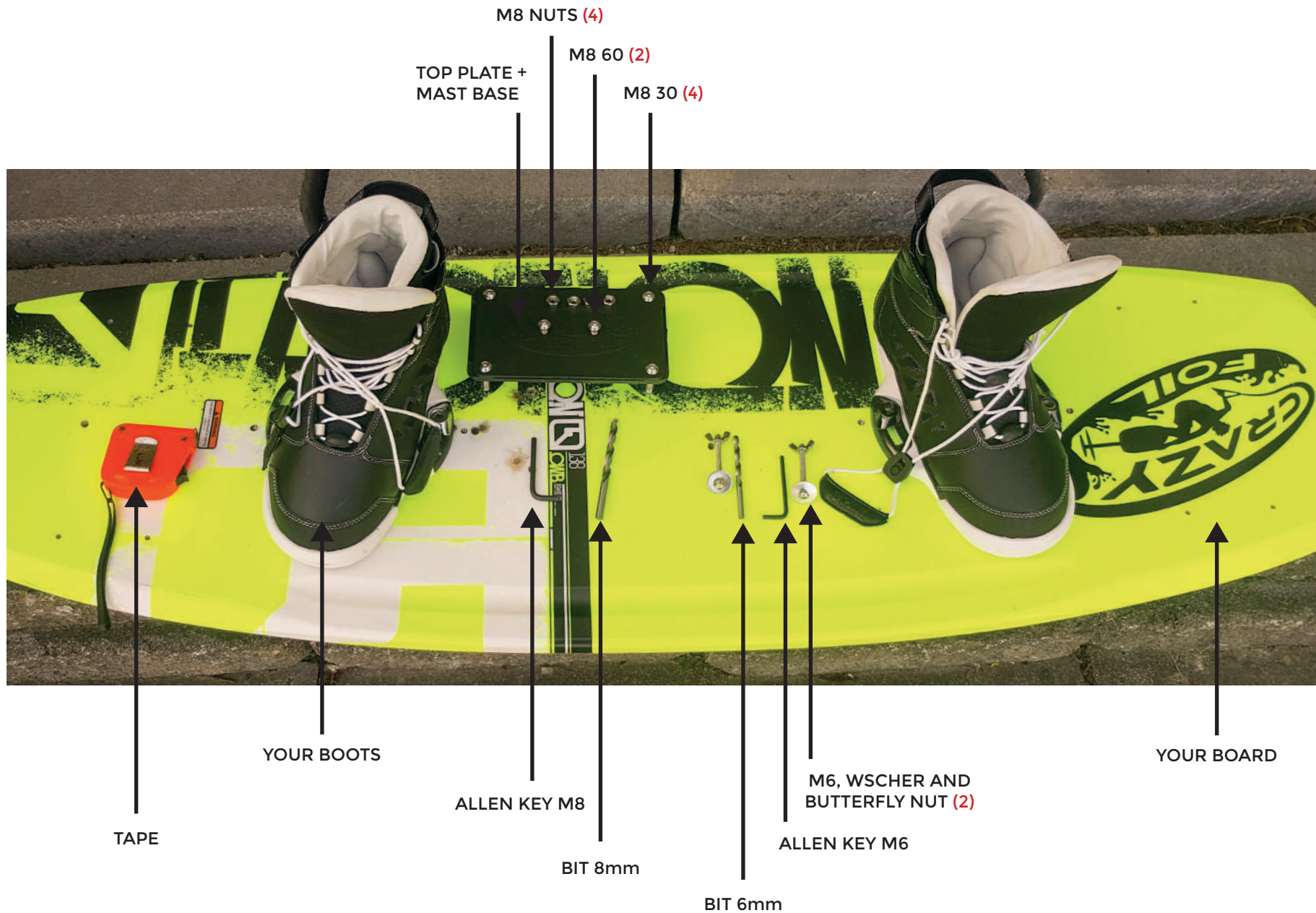

REAR BOOT POSITIONING



A
SELECT LAST BOARD INSERT



B
*FIX THE FRONT SCREW OF THE
REAR BOOT TO THE BOARD*



C
*DRILL 6mm HOLE ON THE
BACK SIDE OF THE BOOT*

1.

REAR BOOT POSITIONING



**INSTALL M6 SCREW AND
WASHER UNDER THE BOARD**



**INSTALL BUTTERFLY NUT ON
TOP TO FIX THE BOOT**



TIGHT THE SCREW

**REAR BOOT IS
INSTALLED**

FRONT BOOT POSITIONING



**SELECT INSERT FOR YOUR
COMFORT**



**FIX THE FRONT SCREW OF THE
FRONT BOOT TO THE BOARD**

2.



**DRILL 6mm HOLE ON THE
BACK SIDE OF THE BOOT**

FRONT BOOT POSITIONING



*INSTALL M6 SCREW AND
WASHER UNDER THE BOARD*



*INSTALL BUTTERFLY NUT ON
TOP TO FIX THE BOOT*



TIGHT THE SCREW

*FRONT BOOT IS
INSTALLED*

BOARD FIXING

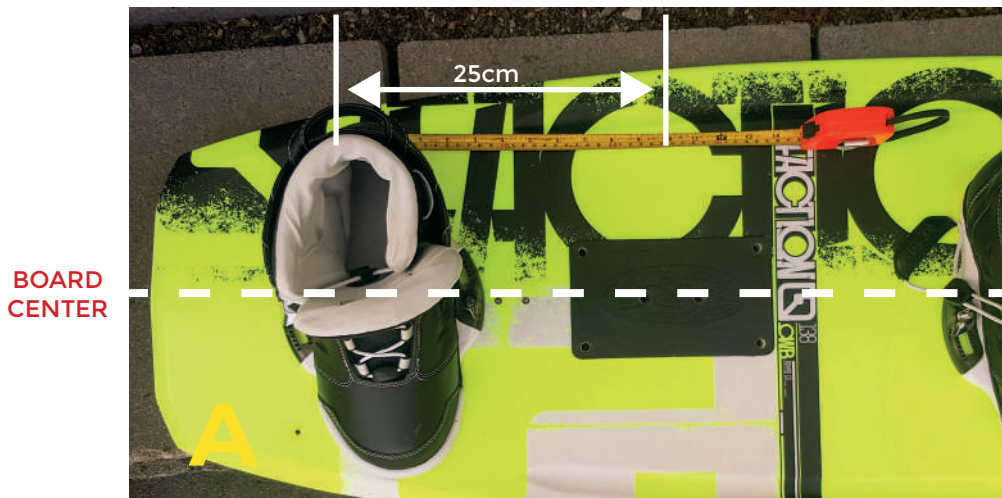

POSITION TOP PLATE ON THE BOARD, MIDDLE OF IT 25cm FROM MIDDLE OF THE REAR FOOT. PLATE CENTERED AND ALIGNED WITH THE BOARD.

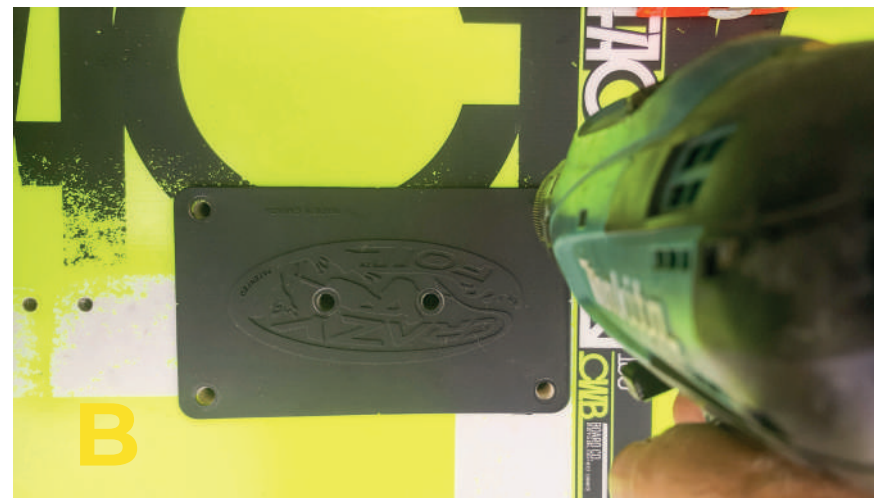

DRILL 4 CORNERS WITH 8mm BIT, USING TOP PLATE AS A TEMPLATE.

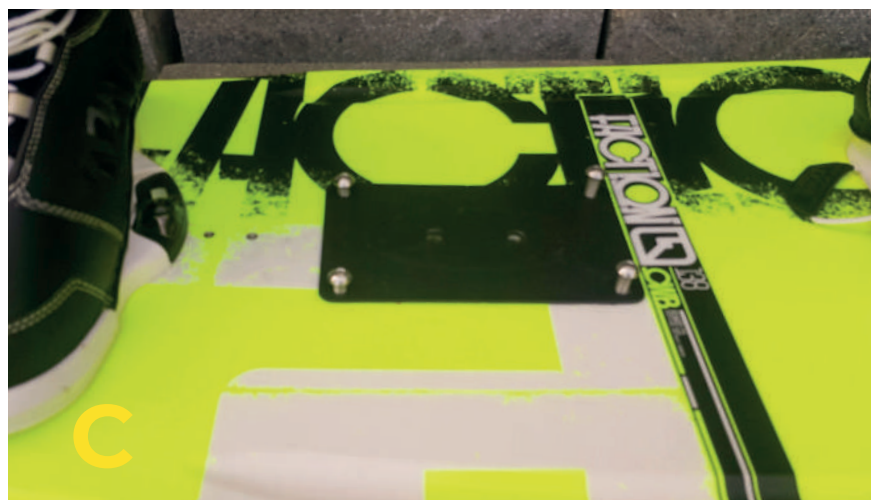

INSTALL M8 40 SCREWS ON 4 CORNERS.

3.

BOARD FIXING



INSTALL THE 4 M8 NUTS



TIGHT THE 4 CORNERS SCREWS

BOARD FIXING



**DRILL 8mm MAST SCREW HOLE
USING BASE MAST AS A TEMPLATE**



**INSTALL MAST UNDER THE BOARD
AND M8 60 ON TOP**



TIGHT THE SCREWS ON THE MAST



**YOUR HYDROFOIL IS
INSTALLED**

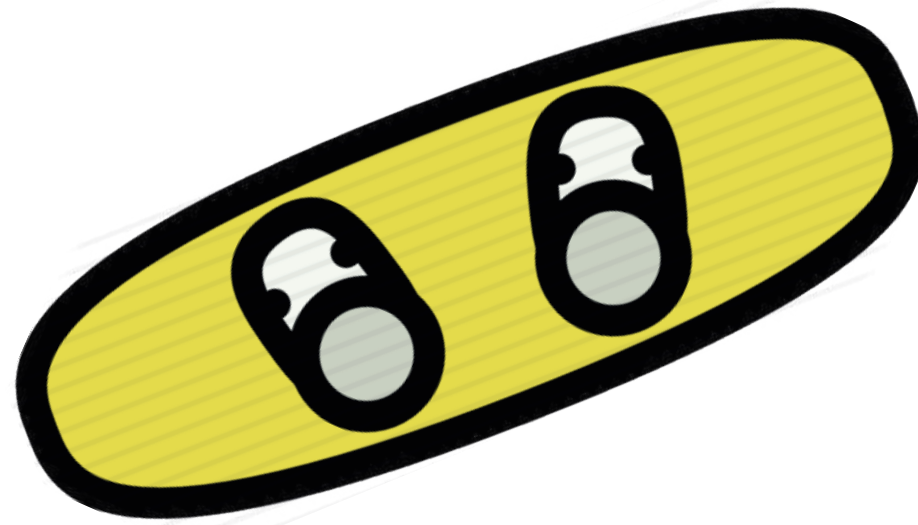

BAREFOOT/STRAPS BOARD FIXING

THE RIGHT POSITION ON BAREFOOT/STRAPS BOARDS

WARNING:

The barefoot practice increases significantly the risks of injury or death.

Reserved to very experienced foil riders. Failure to use an appropriate leash while practicing barefoot may also lead to injury or death to you and others.

*IF USING A BOARD MADE OF SOFT FOAM INSIDE (EXTRUDED POLYSTYRENE, EPS)
TAKE SPECIAL CARE TO FIX THE HYDROFOIL.*

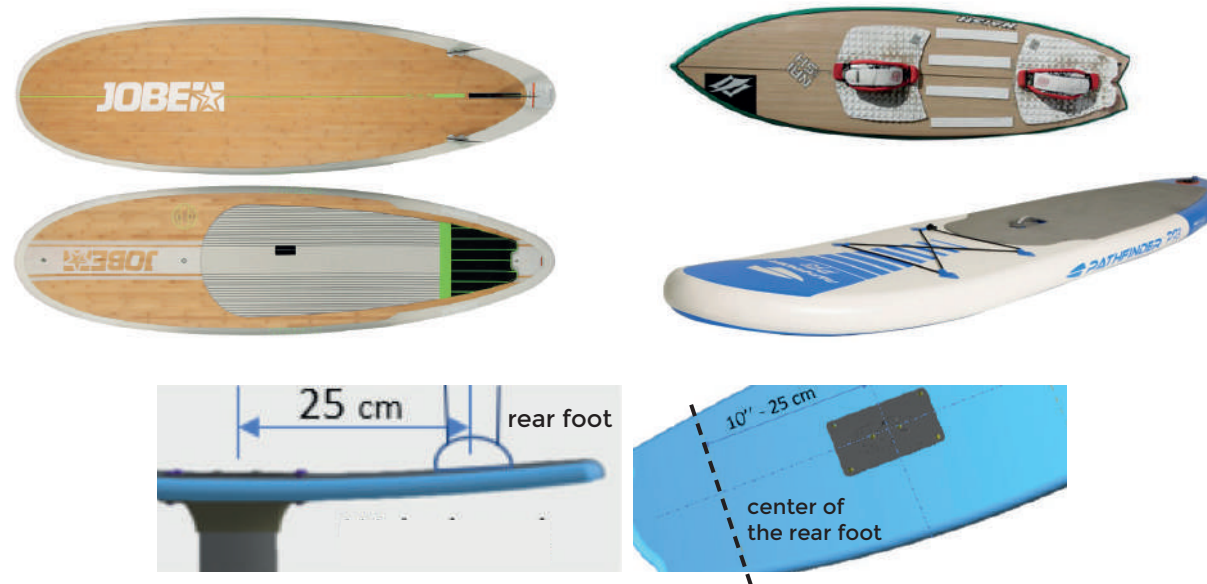

When practicing water sports barefoot, the installation of an hydrofoil on a board is based on the **position of your rear foot while practicing without hydrofoil.**

Identify your «standard» feet position and fix the center of the hydrofoil's mast **25cm from the middle of your rear foot.**