

# Installation & User Manual



# MRCOOL®

COMFORT MADE SIMPLE

## PRODIRECT™ SERIES

Split System Heat Pump & Air Conditioner

15 SEER 1.5-5 Tons Model

HHP150\* & HAC150\*

Due to updates and constantly improving performance, the information and instructions within this manual are subject to change without notice. Please visit [www.mrcool.com/documentation](http://www.mrcool.com/documentation) to ensure you have the latest version of this manual.

Version Date: 2/14/2023

Thank you for choosing MRCOOL. Please read this manual carefully before installation and keep it for future reference.

Copyright © 2023 MRCOOL, LLC



RECOGNIZE THIS SYMBOL AS AN INDICATION OF IMPORTANT SAFETY INFORMATION

 **WARNING**

These instructions are intended as an aid for qualified and licensed service personnel for proper installation, adjustment, and operation of this unit. Read these instructions thoroughly before attempting installation or operation. Failure to follow these instructions may result in improper installation, adjustment, service or maintenance possibly resulting in fire, electrical shock, property damage, personal injury or death.



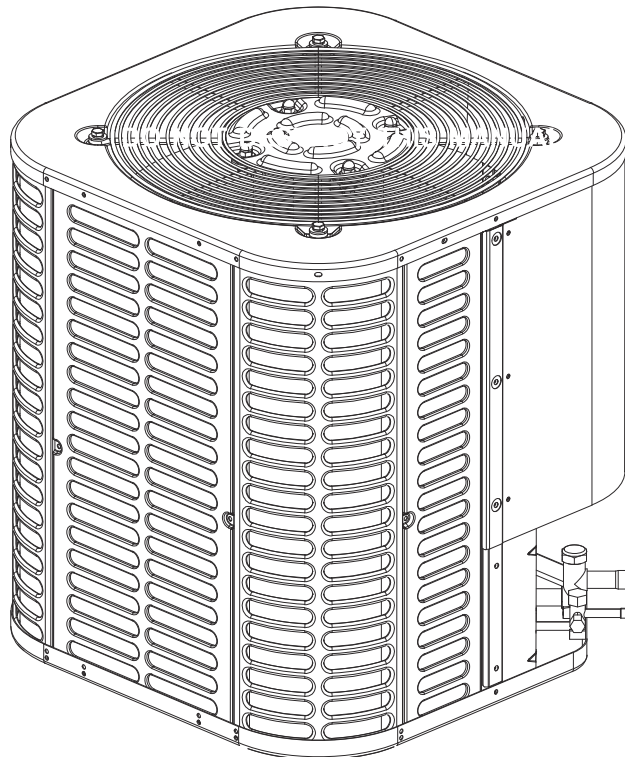
Unitary Small AC  
AHRI Standard 210/240  
Certification applies only when the complete system is listed with AHRI.



Unitary Small HP  
AHRI Standard 210/240  
Certification applies only when the complete system is listed with AHRI.



Please read carefully and keep in a safe place for future reference by a serviceman.



# CONTENTS

1. Symbol and Key to Safety Instructions.....	01
2. Considerations of Unit Location .....	04
3. Unit Installation Preparation .....	08
4. Unit Settings .....	08
5. Precautions for Refrigerant Pipeline.....	09
6. Refrigerant Pipeline Routing .....	11
7. Refrigerant Pipeline Brazing.....	13
8. Refrigerant Pipeline Leakage Inspection.....	15
9. Emptying .....	16
10. Service Valve.....	17
11. Electrical-Low Voltage .....	18
12. Electrical-High Voltage .....	23
13. Start.....	24
14. System Refrigerant Charging Regulation .....	25
15. System Operation and Troubleshooting .....	27
16. Wiring Diagram.....	34
17. Cleaning and Maintenance.....	36

# 1. Symbol and Key to Safety Instructions

## 1.1 Symbol Keywords



### WARNING

The warnings in this document are identified by warning triangles printed on a gray background. The key words at the beginning of the warning indicate the type and severity of the risk if no measures are taken to prevent it.

The following keywords are defined and used in this document:



### Danger

Indicates a dangerous situation, which, if not avoided, will lead to death or serious injury.



### Warning

Indicates a dangerous situation, which, if not avoided, may lead to death or serious injury.



### Caution

Indicates a dangerous situation, which, if not avoided, may cause mild to moderate injury.



### Note

Indicates potential behaviors unrelated to personal injury.

## Important information



This symbol represents important information that is not dangerous to people or property.

## 1.2 Safety

Please Read Before Continuing.



### WARNING



Failure to observe this warning may result in property damage, serious personal injury or death.



Before touching the electrical components, wait for 3 minutes after disconnecting the power supply.



### NOTE



This document is the property of the customer and should be retained for any future maintenance or repair needs.



These instructions do not cover all changes in the system, nor do they provide all unexpected situations that may be encountered during installation.



If you need more information, or there are special situations that are not covered in this installation manual, please consult our tech support department at (270) 366-0457.



Some benefits of installing compatible indoor and outdoor units are maximum efficiency, best performance and best overall system reliability.



This document contains wiring diagrams and maintenance information and should be retained by the customer in case of future repair needs.

---

### Warning:



- This appliance is not intended for use by persons (including children) with reduced physical, sensory or mental capabilities, or lack of experience and knowledge, unless they have been given supervision or instruction concerning use of the appliance by a person responsible for their safety.
  - The appliance shall be installed in accordance with national wiring regulations.
  - Before accessing the connection terminals, all power circuits must be disconnected.
  - This information is intended for use by individuals with an experienced electrical and mechanical background. Attempting to repair central air conditioning products without experience may result in personal injury and/or property damage.
- 



### Warning: Dangerous Voltage

- Failure to observe this warning may result in property damage, serious personal injury, or death.
  - Disconnect all power before maintenance, including remote disconnection. Follow proper locking/tagging procedures to ensure that the power supply will not be energized accidentally.
- 



### Warning: Refrigerant Oil

- Attempting to repair central air-conditioning products without proper training may result in property damage, serious personal injury or death. These units use R-410A refrigerant, and its working pressure is 70% higher than R-22. Use only the service equipment approved by R-410A. The refrigerant cylinder is painted a rose color to indicate the type of refrigerant, and may contain a "dip" tube to allow liquid refrigerant to be filled into the system. All R-410A systems use POE oil (VG74 or equivalent), which can easily absorb moisture from the atmosphere. In order to limit this "moisture absorption" effect, the system should be sealed as much as possible. If the system is exposed to the atmosphere for more than 4 hours, the compressor oil must be changed. Do not destroy the vacuum with air, and always replace the dryer when you open the system for component replacement.
- 



### Warning: Hot Surface

- Touching the top of the compressor may cause mild to severe burns. Failure to observe this caution may result in property damage or personal injury.
- 



### Caution: Contains Refrigerant

- Failure to follow the correct procedures will lead to personal illness or injury or serious equipment damage. The system contains high-pressure oil and refrigerant. Before opening the system, recover the refrigerant to release the pressure.
-



### Note: Indoor Unit Required

- Indoor unit is equipped with piston or TXV, and the model of piston and TXV is selected by manufacturer, please do not change by yourself.
- 



### Note: Grounding Required

- Failure to check or use the correct maintenance tools may result in equipment damage or personal injury. Reconnect all grounding devices. All parts of this product that can conduct current are grounded. If the grounding wire, screw, strap, clip, nut or washer used to complete the grounding path is removed during maintenance, it must be put back in place and properly secured.
- 



### Warning: Service Valve

- Failure to observe this warning will result in sudden discharge of system charge, which may result in personal injury and/or property damage. When opening the liquid pipeline service valve, be extra careful. Turn the valve stem counterclockwise until the valve stem touches the bead.
- 



### Warning: Brazing Required

- Failure to check the wiring or use the correct maintenance tools may result in equipment damage or personal injury. If using existing refrigerant lines, ensure that all joints are brazed, not soldered.
- 



### Warning: High Current Leakage

- Failure to observe this warning may result in property damage, serious personal injury, or death. Before connecting the power supply, grounding is essential.
- 



### Warning:

- This product may cause exposure to chemicals including lead and lead components, which are known in California to cause cancer, birth defects or other reproductive harm. For more information, please visit [www.P65Warnings.ca.gov](http://www.P65Warnings.ca.gov).
-

## 2. Considerations of Unit Location

### 2.1 Unit Size

**Table 2.1 Outdoor Operating Temperature**

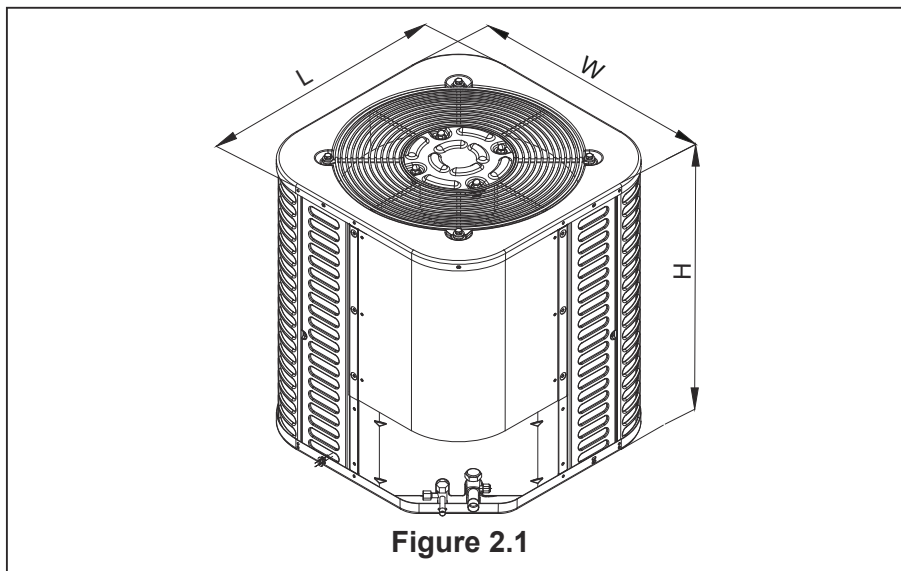
Model	Temperature
Cooling mode	57-115°F
General heat pump mode	19-75°F
High vertical heat pump mode	32-75°F

**Table 2.2**

Unit size	
Model	H x W x L (inches)
18K/24K(AC)	25 x 21-4/5 x 21-4/5
24K(HP)/ 30K/36K	25 x 29-1/7 x 29-1/7
42K/48K/60K	32-7/8 x 29-1/7 x 29-1/7

The weight of the unit is attached to the carton.

When installing the outdoor unit on the roof, make sure that the roof can support the weight of the outdoor unit. It is recommended to choose appropriate isolation to prevent sound or vibration from being transmitted to the building structure.



## 2.2 Refrigerant Pipeline Restriction

**Table 2.3 Heat pump types in general mode**

Refrigerant Piping		Capacity (Kbtu/h)						
		18K	24K	30K	36K	42K	48K	60K
Liquid-Gas	In.	3/8-3/4	3/8-3/4	3/8-3/4	3/8-3/4	3/8-3/4	3/8-7/8	3/8-7/8
Max. Refrigerant Line Length*	Ft.	100				150		
Max. Vertical Lift	Ft.	26				33		

\*It is recommended to adopt standard pipeline size; Refrigerant charge: see Section 14.

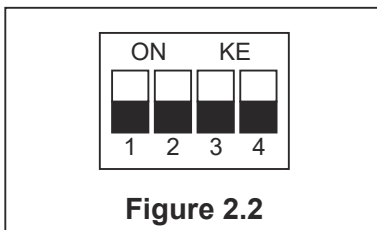


If the pipeline length or high vertical of the above models exceeds the data in Table 2.3, please set the high vertical mode dial according to the data range in Table 2.4, and refer to Table 2.5 for the dip switch diagram.

**Table 2.4 Heat pump types in high vertical mode**

Refrigerant Piping		Capacity (Kbtu/h)						
		18K	24K	30K	36K	42K	48K	60K
Liquid-Gas	In.	3/8-3/4	3/8-3/4	3/8-3/4	3/8-3/4	3/8-3/4	3/8-7/8	3/8-7/8
Max. Refrigerant Line Length*	Ft.	130						
Max. Vertical Lift	Ft.	60						

\*It is recommended to adopt standard pipeline size; Refrigerant charge: see Section 14.



**Table 2.5 Dip Switch Diagram**

Dial switch	ON	OFF
SW1-2	High-vertical mode	General mode

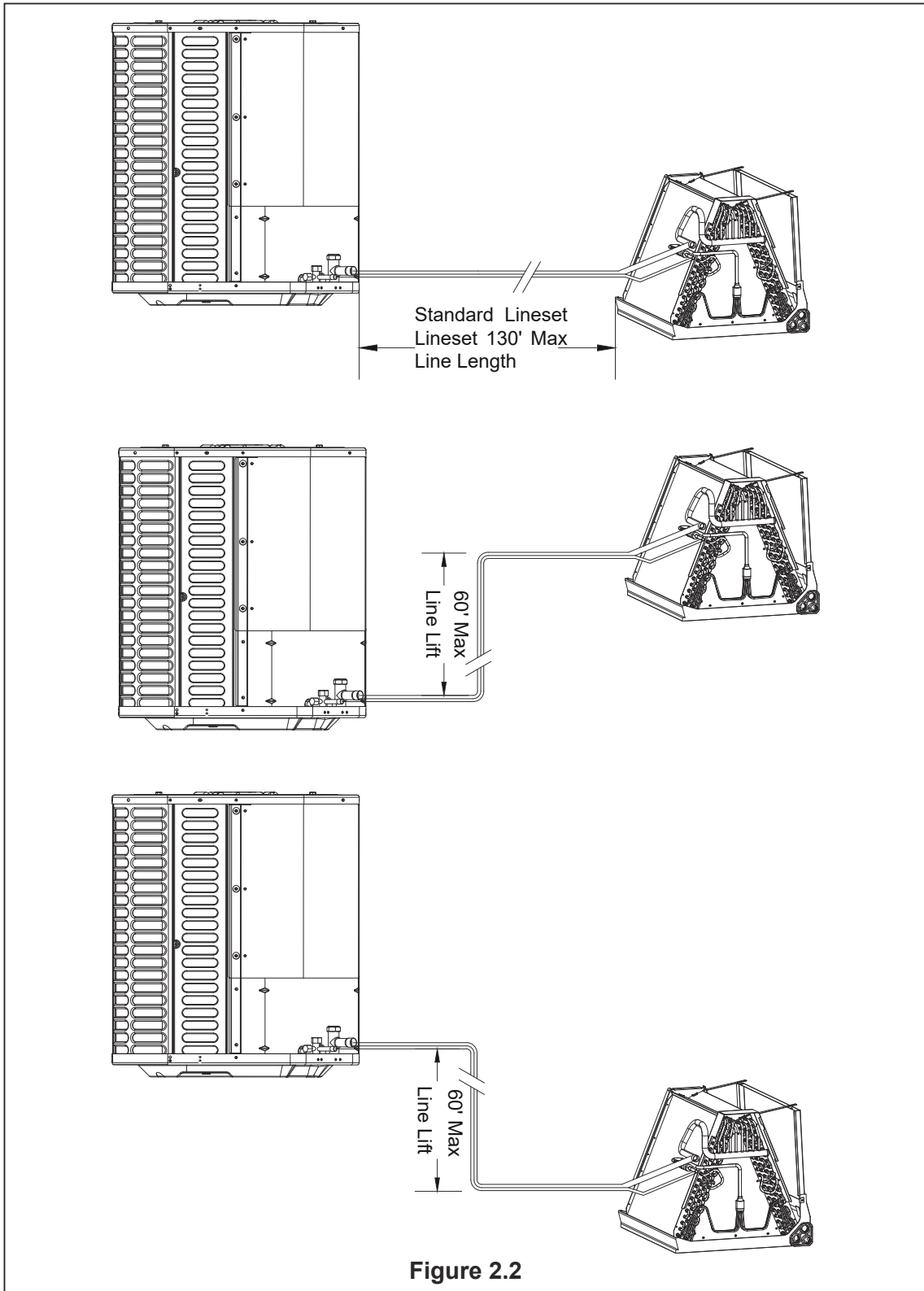
**Table 2.6 Cooling only types**

Refrigerant Piping		Capacity (Kbtu/h)						
		18K	24K	30K	36K	42K	48K	60K
Liquid-Gas	In.	3/8-3/4	3/8-3/4	3/8-3/4	3/8-3/4	3/8-3/4	3/8-7/8	3/8-7/8
Max. Refrigerant Line Length*	Ft.	130						
Max. Vertical Lift	Ft.	60						

\*It is recommended to adopt standard pipeline size; Refrigerant charge: see Section 14.

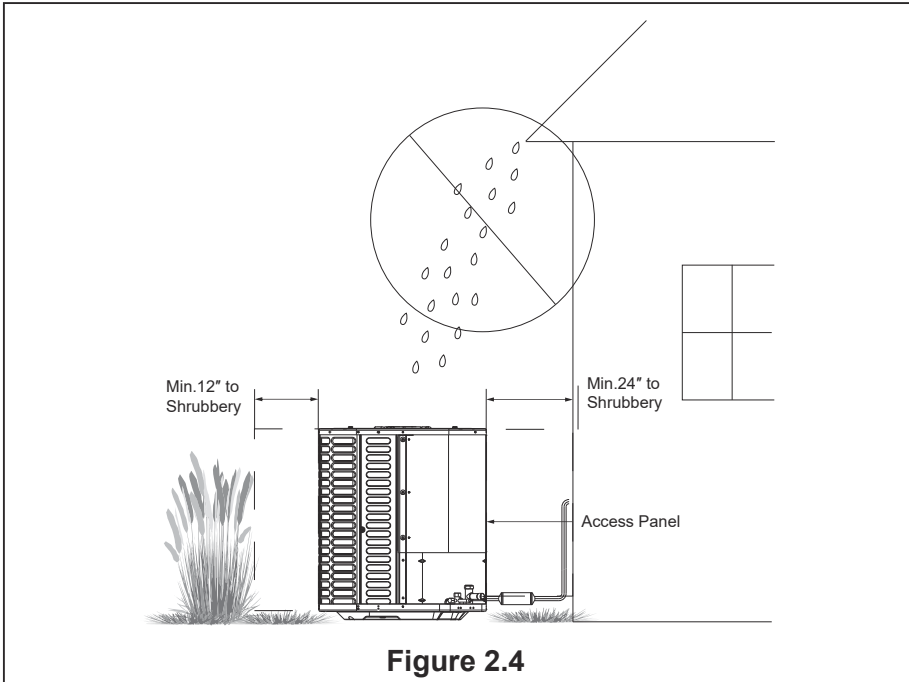
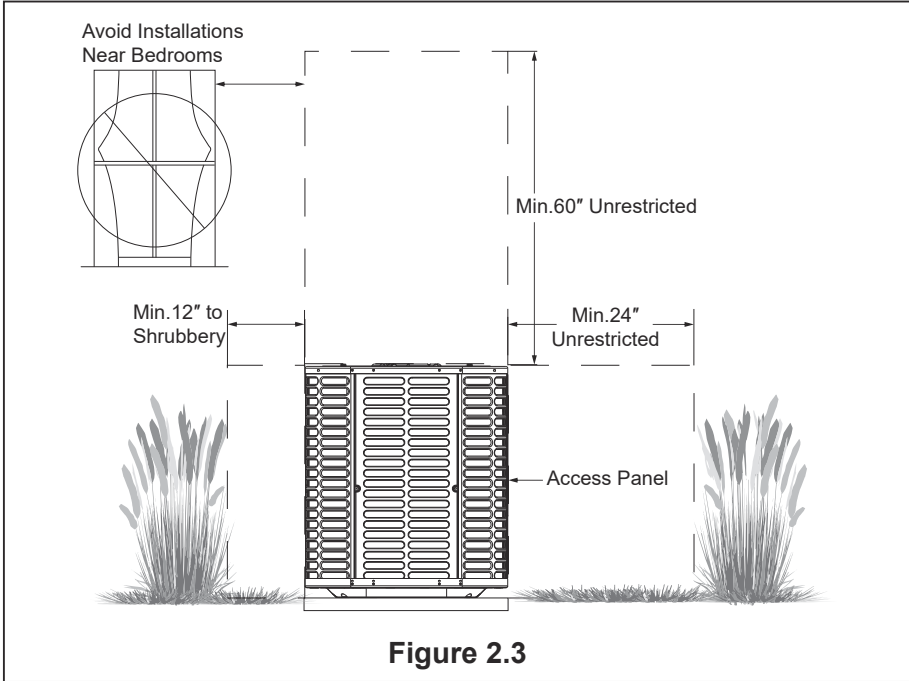


- ▶ Maximum equivalent length of pipeline = 130 feet.
- ▶ Maximum vertical equivalent length = 60 feet.
- ▶ Use only the pipe diameters shown in Table 2.2.
- ▶ If the suction line exceeds 60 feet, refer to Section 2.2 for recommended suction line size.



### 2.3 Position Restriction

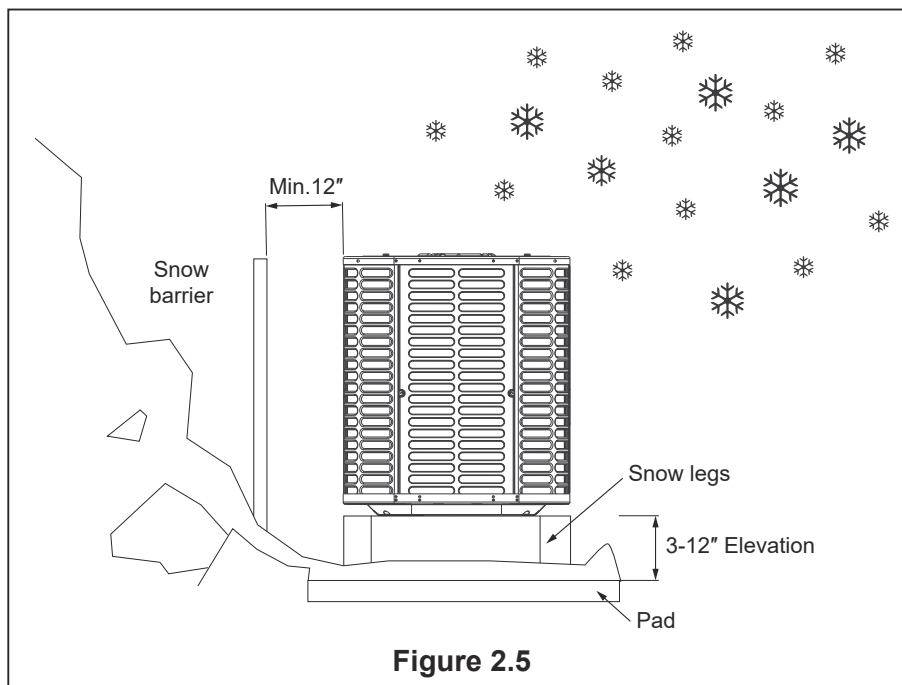
- Make sure that the discharge area (at least 60 inches above the top of the unit) is unrestricted.
- Don't place the outdoor unit near a bedroom, as the normal operating sound may be disruptive.
- Position the equipment, leaving enough space for smooth airflow, wiring, refrigerant lines, and maintainability.
- There should be a minimum of 12 inches of clearance around the unit. However, there should be at least 24 inches of clearance on the side with the access panel.
- Keep a distance of 24 inches between adjacent units.
- Place the unit in a place where water, snow, or ice cannot fall directly on the device from the roof or overhangs.
- See figures 2.3 and 2.4.





Precautions must be taken for units installed in areas with snow and long-term temperatures below freezing point.

- Depending on the local weather conditions, the unit should be raised between 3 and 12 inches. This extra height will allow the snow and ice melted during the defrosting cycle to be discharged before re-freezing. Make sure that the drain hole on the unit chassis is not blocked, otherwise it will hinder the defrosting water discharge (Figure 2.5).
- If possible, avoid places that are prone to snow. If this is not feasible, a snow barrier should be installed around the unit to prevent snow accumulation on the side of the unit.



### **Corrosive Environment**

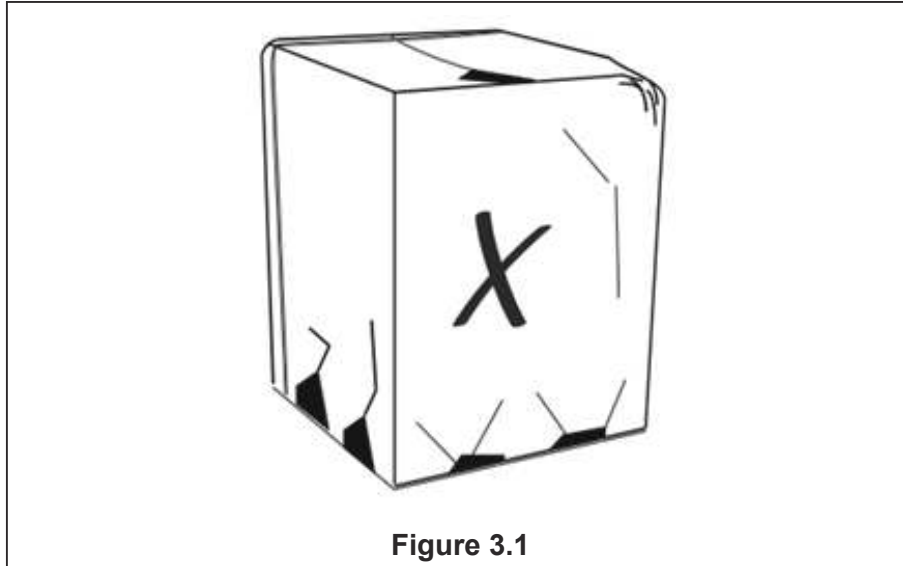
Exposure to a corrosive environment may shorten the service life of the unit, corrode metal parts, and/or negatively affect the performance of unit. Corrosive elements include but are not limited to: sodium chloride, sodium hydroxide, sodium sulfate, and other compounds commonly found in seawater, sulfur, chlorine, fluorine, fertilizers, and various chemical pollutants from industrial/manufacturing plants. If it is installed in an area that may be exposed to a corrosive environment, special attention should be paid to the placement and maintenance of the unit.

- Lawn sprinklers/hoses/waste water should not be sprayed directly on the outer panel of the unit for an extended period of time.
- In coastal areas: install the unit on a side facing away from the waterfront.
- Fences or shrubs can provide some shielding protection for the unit, but be sure to keep the minimum device clearance.
- Clean the outdoor coil and any exposed external surfaces approximately every three months.

## 3. Unit Installation Preparation

### 3.1 Prepare the Unit for Installation

- Check for damage to the unit and report any damage to the carrier immediately. (Figure 3.1).
- The filler can be used to ensure that the refrigerant charge is maintained during shipment.



## 4. Unit Settings

### 4.1 Support Pad Installation

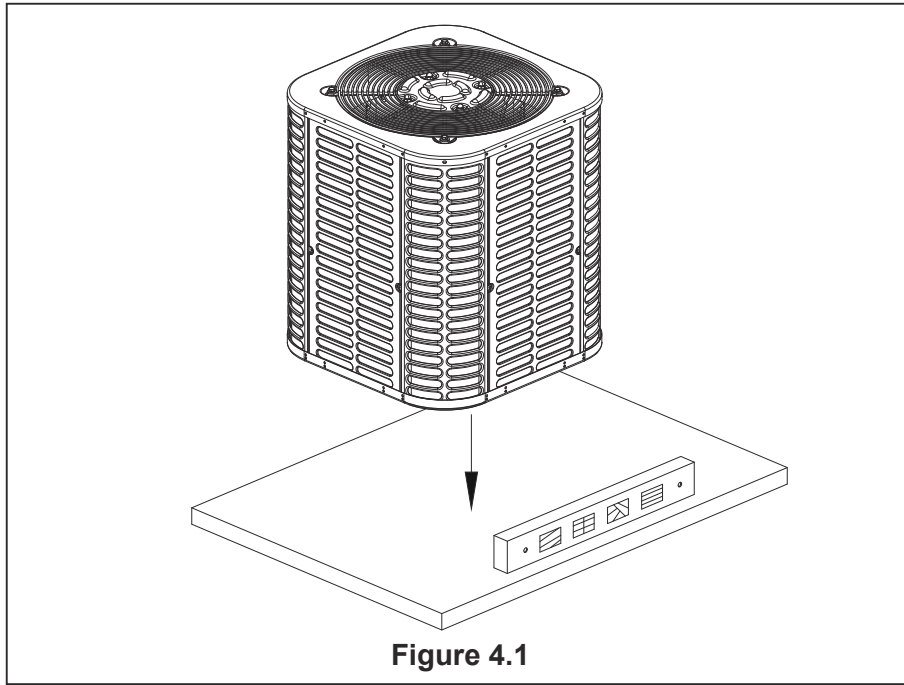
When installing the unit on a support pad (such as a concrete slab), please consider the following:

- All sides of the pad must be at least 1-2 inches larger than the unit.
- The pad must be separated from any structure.
- The pad must be level.
- The pad must be high enough above the ground for drainage.
- The location of the pad must comply with national, state and local regulations.



These instructions are intended to provide a method of securing the system to the cement slab as a anchoring procedure in windy areas. Check the local regulations of tie-down methods and protocols.

---



## 5. Precautions for Refrigerant Pipeline

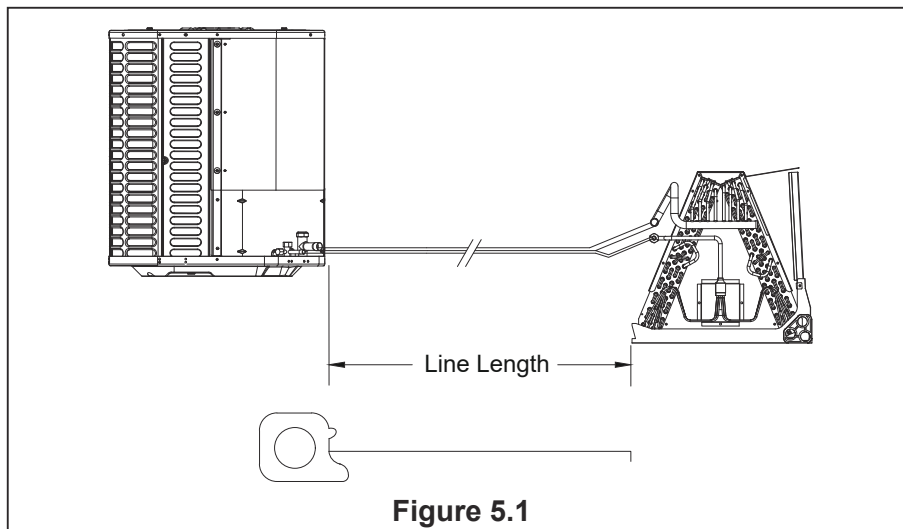
### 5.1 Connecting Dimensions of Refrigerant Lines and Service Valves

**Table 5.1**

Model	Suction line	Liquid line	Suction line connection	Liquid line connection
	The dimensions are in inches.			
18K/24K/30K/36K/42K	3/4	3/8	3/4	3/8
48K/60K	7/8	3/8	7/8	3/8

### 5.2 Length of Required Refrigerant Pipeline

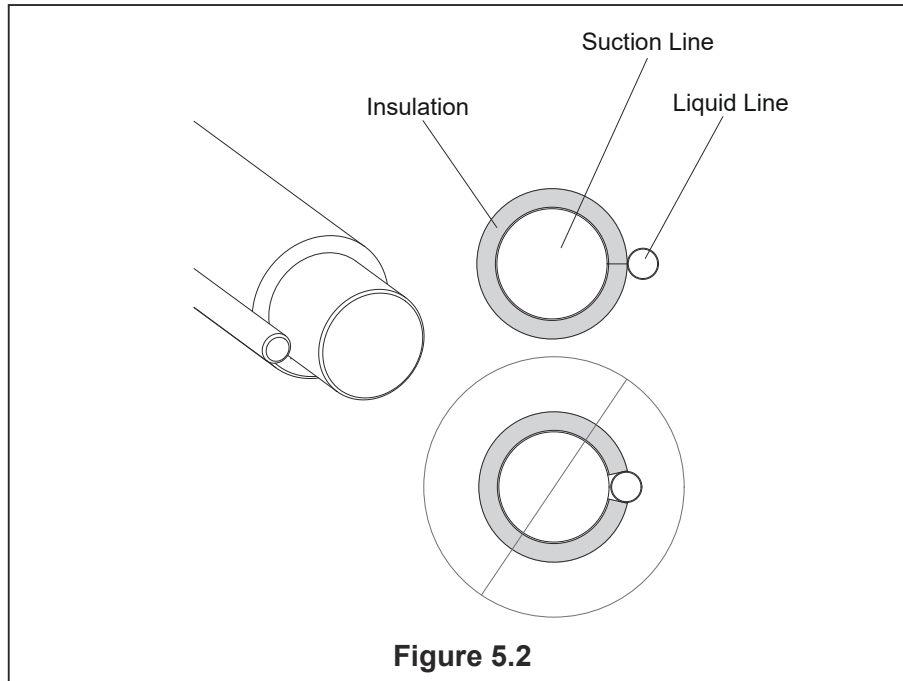
Determine the required pipeline length (Figure 5.1). Please refer to Section 2.2.



## 5.3 Refrigerant Pipe Insulation



The air pipe must always be insulated. Do not let the liquid pipeline and gas pipeline come into direct contact (metal to metal).



## 5.4 Reusing the Existing Refrigerant Lines



### Note: Mild to Moderate Burns

- If using existing refrigerant lines, make sure that all joints are brazed, not soldered.

The following precautions should be taken for the retrofit application that will use the existing refrigerant pipeline:

- Make sure the refrigerant line size is correct. Refer to Section 2.2 and Table 2.2.
- Make sure the refrigerant line is free of leakage, acid, and oil.



The manufacturer recommends that only approved matching indoor and outdoor systems be installed. All split systems are certificated by AHRI, and the indoor unit is equipped with piston or TXV. The model of piston and TXV is selected by the manufacturer, please do not change by yourself. The benefits of installing an approved indoor and outdoor split system are maximum efficiency, best performance, and best overall system reliability.

## 6. Refrigerant Pipeline Routing

### 6.1 Preventive Measure

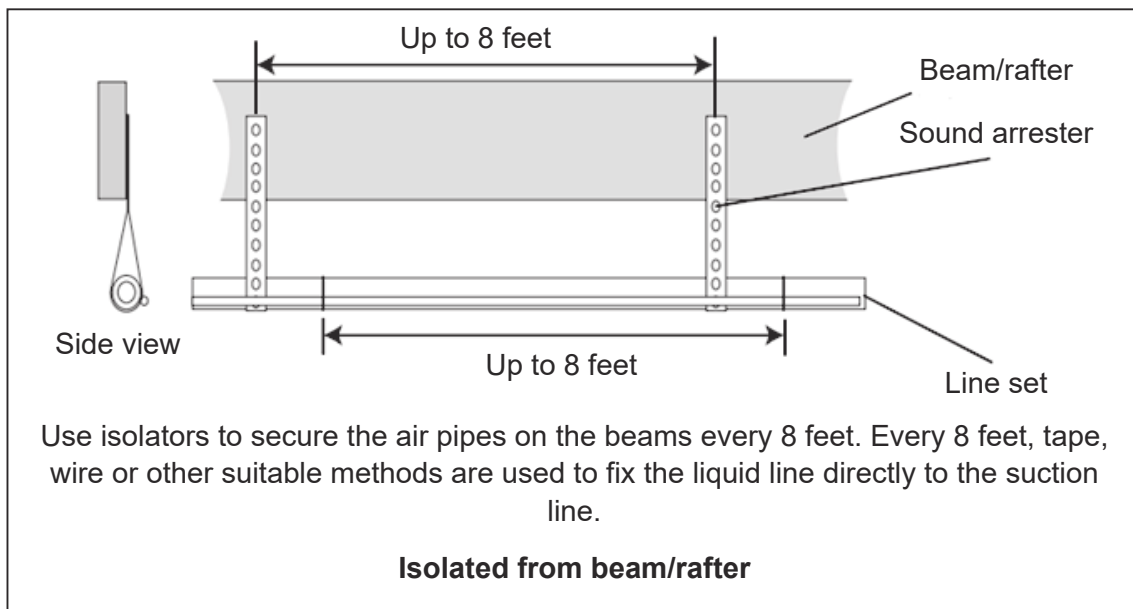


Take preventive measures to prevent noise generated by vibration transmission of refrigerant pipeline in building structure. For example:

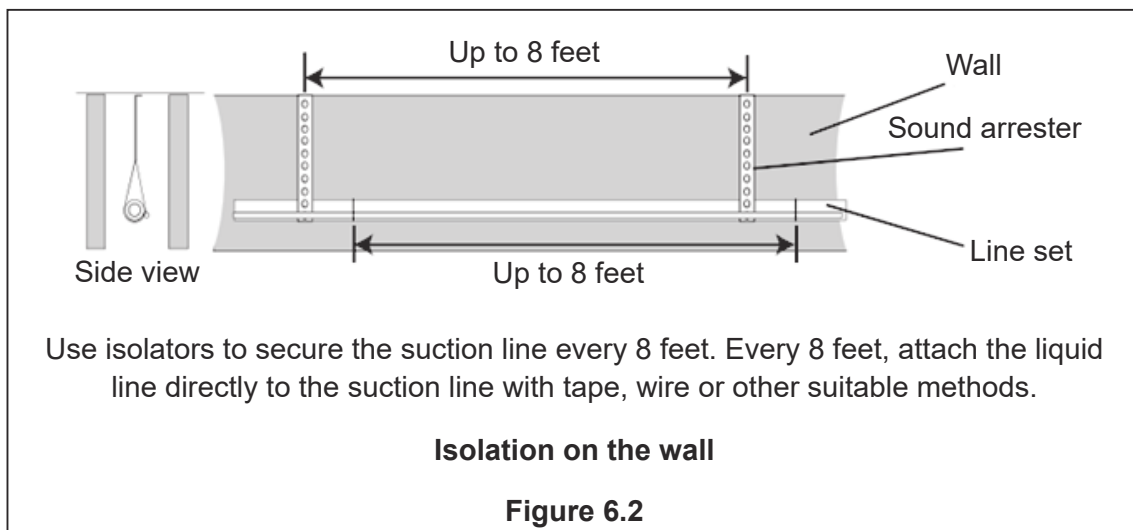
- When the refrigerant pipeline must be fixed on floor joists or other frames in the structure, use isolated hangers.
- When the refrigerant pipeline runs in the column space or closed ceiling, the isolation hanger should also be used.
- When refrigerant lines pass through walls or window sills, they should be insulated and isolated.
- Isolate the pipeline from all piping systems.
- Try to reduce the number of 90° laps.



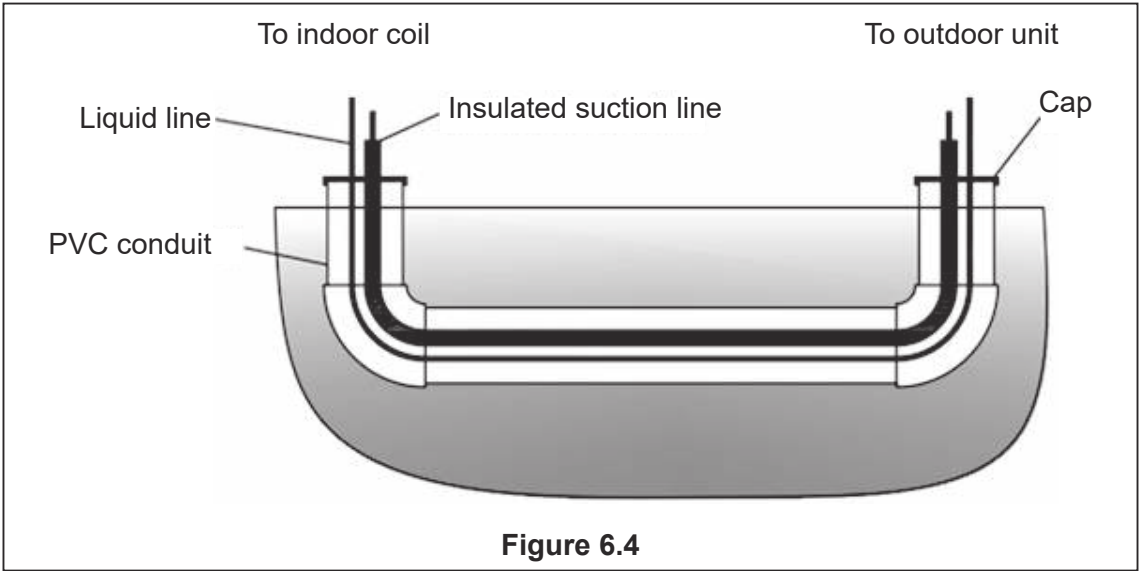
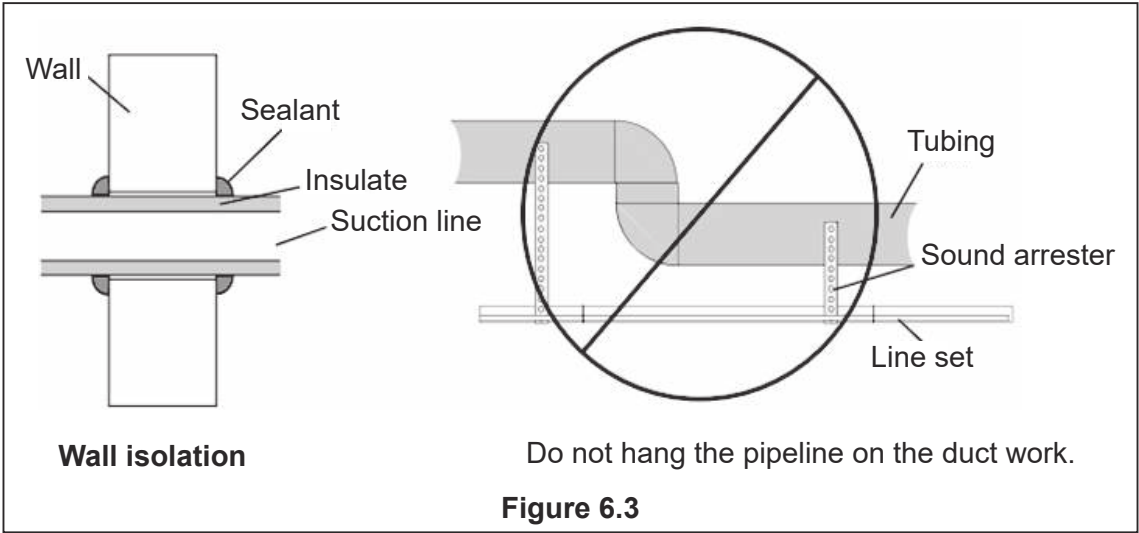
Comply with national, state, and local regulations when isolating the wire group from joists, rafters, walls, or other structural elements.



**Figure 6.1**



**Figure 6.2**

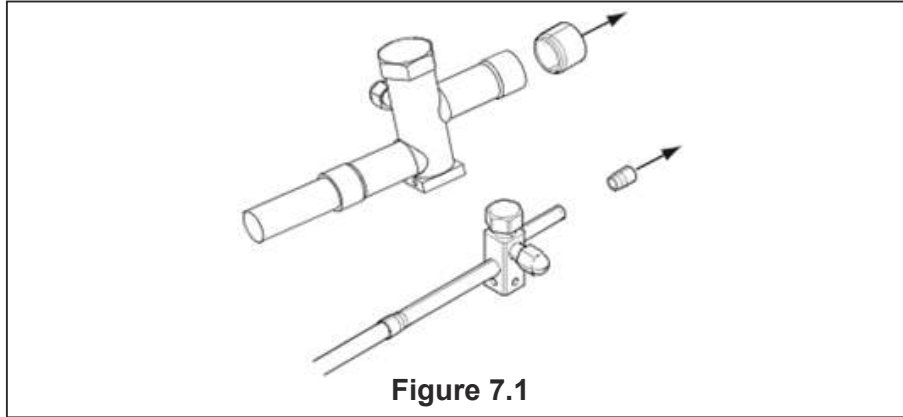




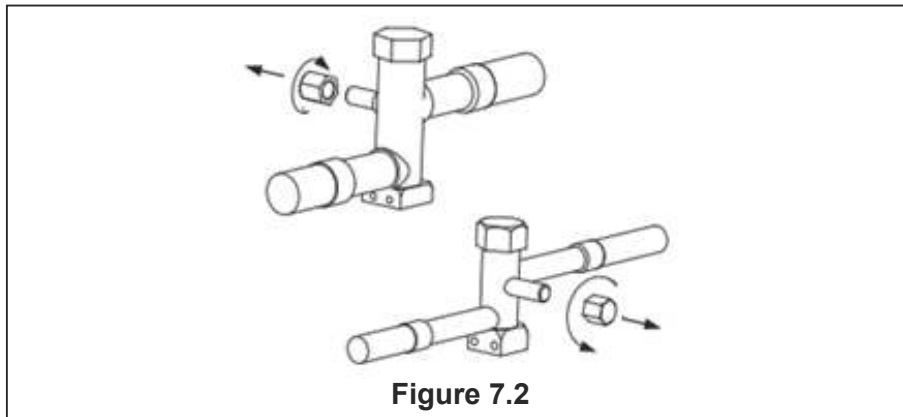
## 7. Refrigerant Pipeline Brazing

### 7.1 Brazing Refrigerant Pipeline

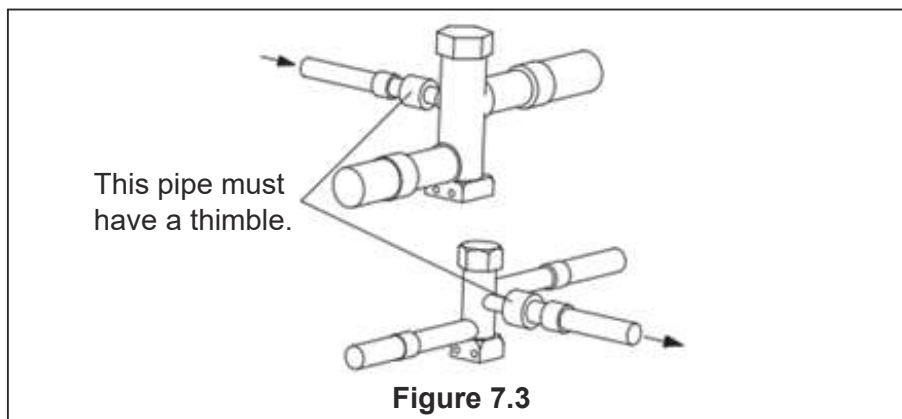
1. Remove the cover or plug. Use the deburring tool to deburr the pipe end. Clean the inner and outer surfaces of the pipeline with emery cloth.



2. Remove the pressure taps from the two service valves.



3. Purge refrigerant lines and indoor coils with dry nitrogen.



4. Wrap the valve body with a wet rag to avoid thermal damage, and continue the dry nitrogen purging (Figure 16).

Braze the refrigerant line to the service valve.

Braze the filter dryer to the liquid pipe.

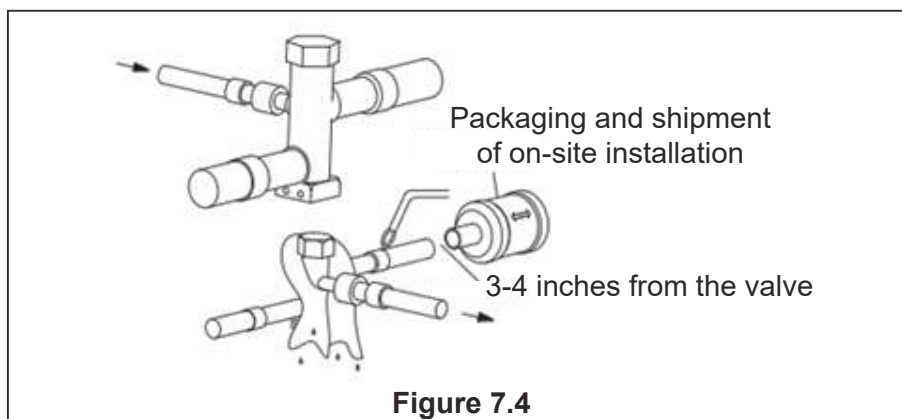


All units are recommended to have bidirectional drying filters installed. Braze the drying filter to the liquid pipe, taking care not to push the refrigerant pipe too hard through the stopper in the drying filter (this may damage the dryer).

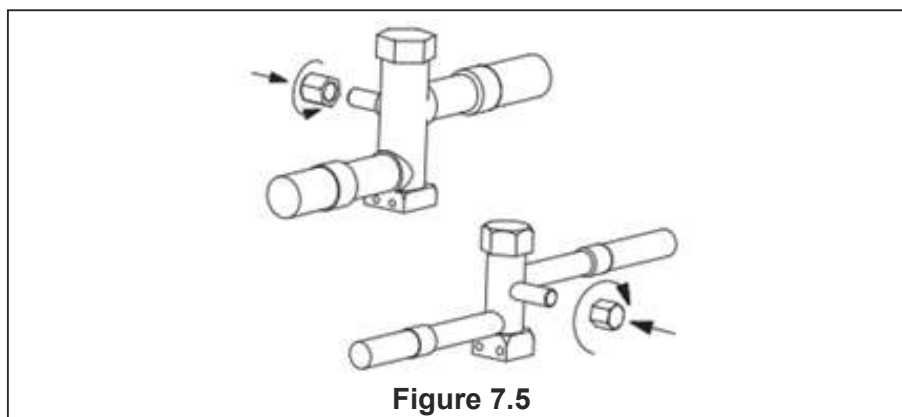
Continue the dry nitrogen purge. Don't take off the wet rag before all brazing is completed.



Before stopping the dry nitrogen purge, please remove the wet rag.



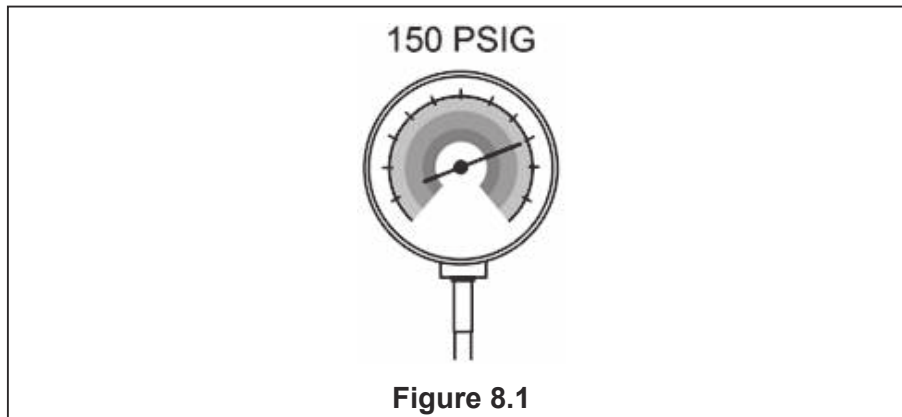
5. After the service valve cools down, replace the pressure tap.



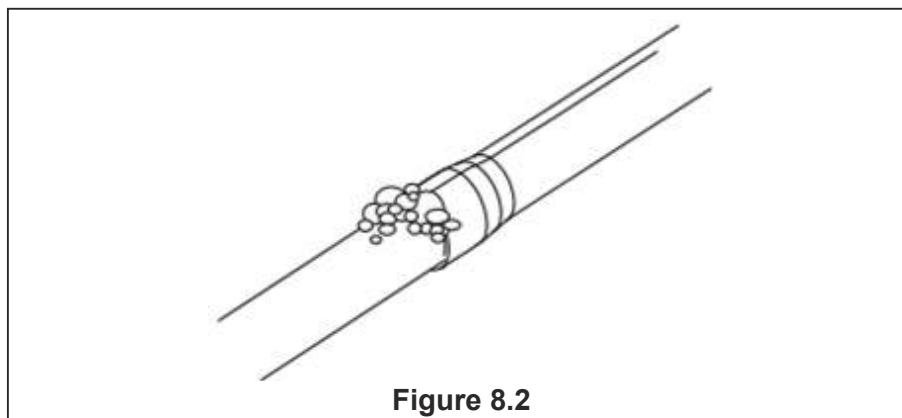
## 8. Refrigerant Pipeline Leakage Inspection

### 8.1 Check for Leaks

1. Use dry nitrogen to pressurize the refrigerant line and evaporator coil to 150 PSIG.



2. Use soapy water or foam at each brazing position to check for leaks.



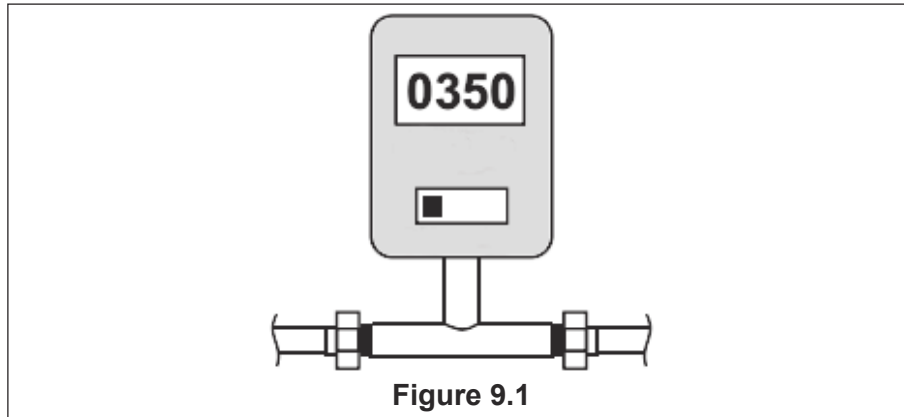
## 9. Emptying

### 9.1 Emptying Refrigerant Pipeline and Indoor Coil



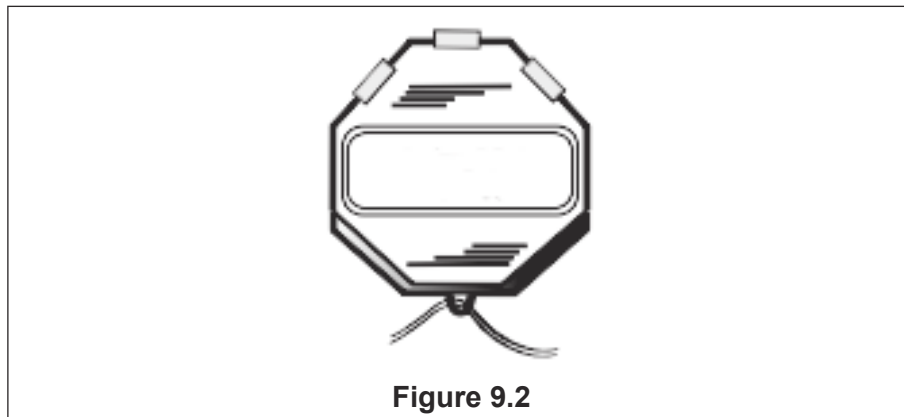
Do not open the service valve until the leakage inspection and emptying of refrigerant lines and indoor coils are completed.

1. Evacuate until the micrometer reading is not higher than 350 micrometers, and then close the valve of the vacuum pump.



2. Observe micrometer gauge. If the micrometer meter does not rise above 500 micrometers within one (1) minute, the evacuation is completed.

After the evacuation, turn off the vacuum pump and micrometer, and close the valve on the manifold instrument cluster.



# 10. Service Valve

## 10.1 Open the Service Valve



### Warning: Moderate to Severe Burns

- When opening the liquid side service valve, be extra careful. Turn counterclockwise until the valve stem just touches the hem. No torque is required. Failure to observe this warning will result in sudden release of system pressure, and may result in personal injury and/or property damage.

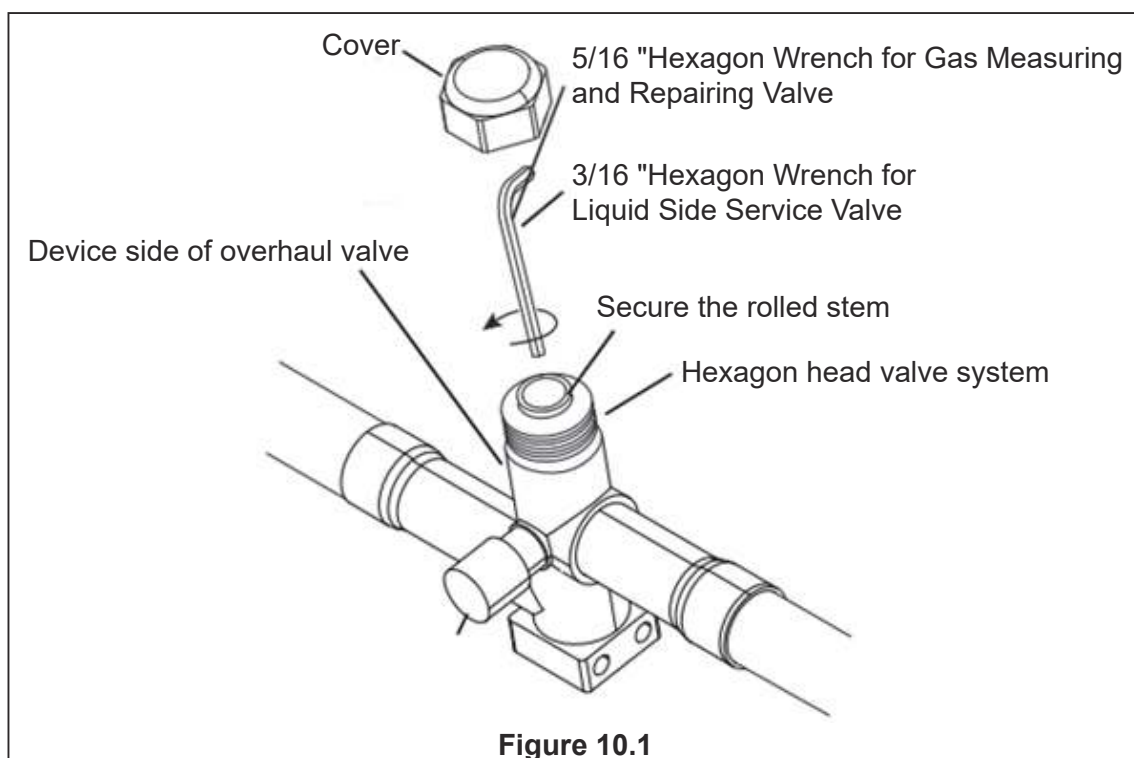


Before opening the service valve, the leakage inspection and emptying must be completed. The valve of copper welded pipe installation should be used for leakage inspection and vacuum pumping. The use of a separate suction port in this process will lead to refrigerant loss.



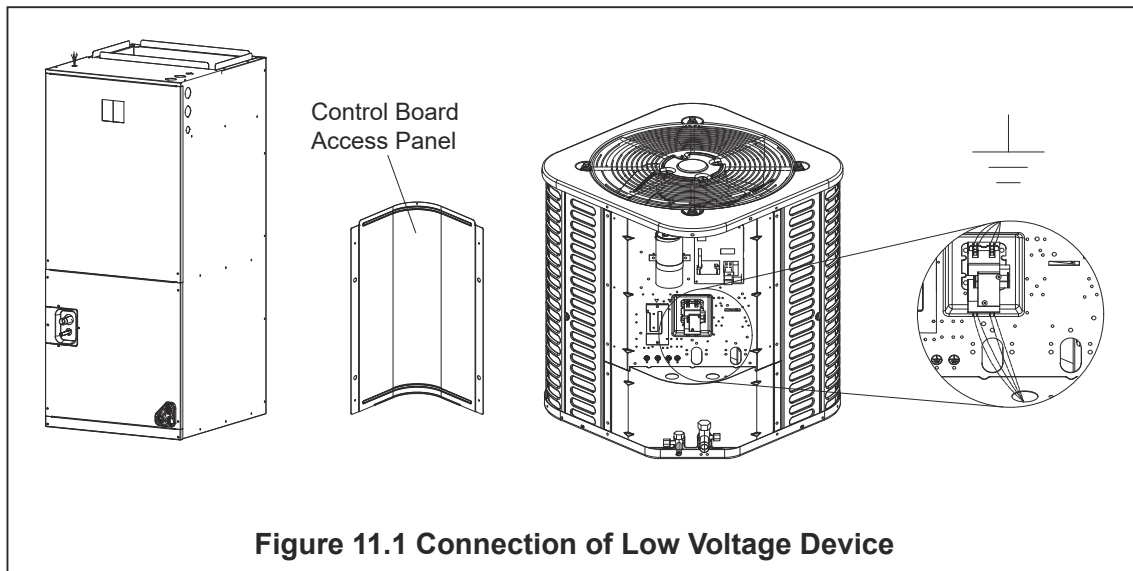
Before opening the liquid side service valve, the gas side service valve must be opened first.

1. Remove the valve cover (Figure 10.1).
2. Insert the hex wrench into the valve stem completely and back out counterclockwise until the valve stem just touches the bead (about five (5) turns.)
3. Replace the valve stem cap to prevent leakage. Tighten it with your fingers first, then, using a crescent wrench, turn it for another 1/6 turn.
4. Repeat steps 1-3 for the liquid side service valve.



# 11. Electrical-Low Voltage

## 11.1 Low Voltage Connection Diagram



## 11.2 Wiring Diagram of Thermostat

- Ensure that the power supply is consistent with the nameplate of the unit.
- The power connection and grounding of the unit must comply with local regulations.
- Low-voltage wiring is the smallest conductor of NO. 22AWG.
- "-----"On-site installation of electrical auxiliary thermal connection
- Single-stage electric auxiliary heating supported by 2H thermostat.
- Two-stage electric auxiliary heating supported by 3H thermostat.
- W1: The first stage of electric auxiliary heating installed in the indoor unit.
- W2: The second stage of electric auxiliary heating installed in the indoor unit.
- The W signal of the outdoor unit is connected to the electric auxiliary heating or the first-stage electric auxiliary heat.

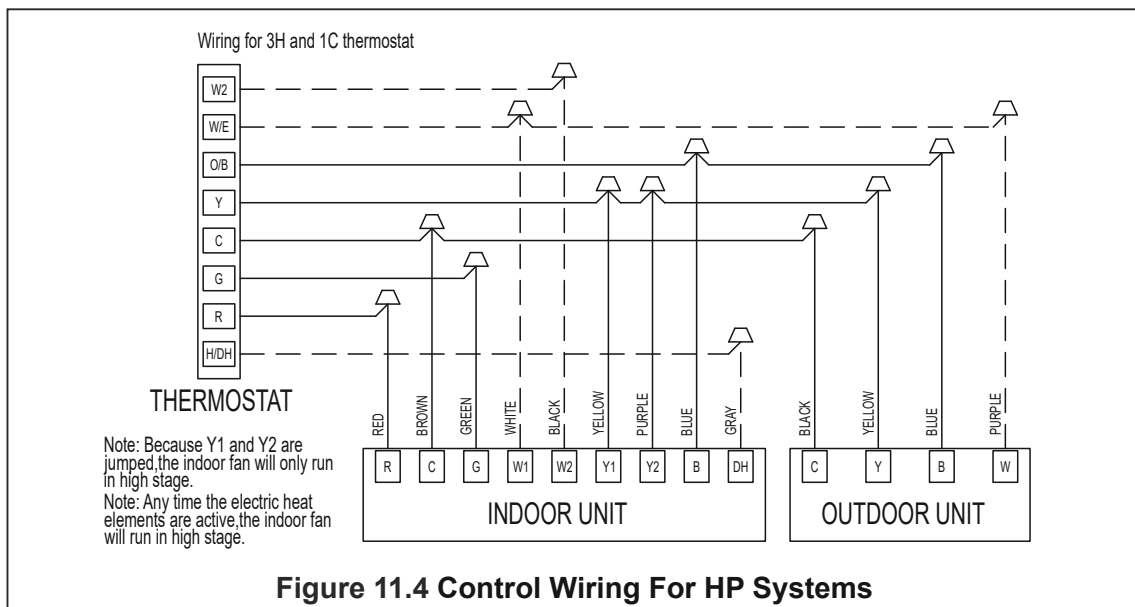
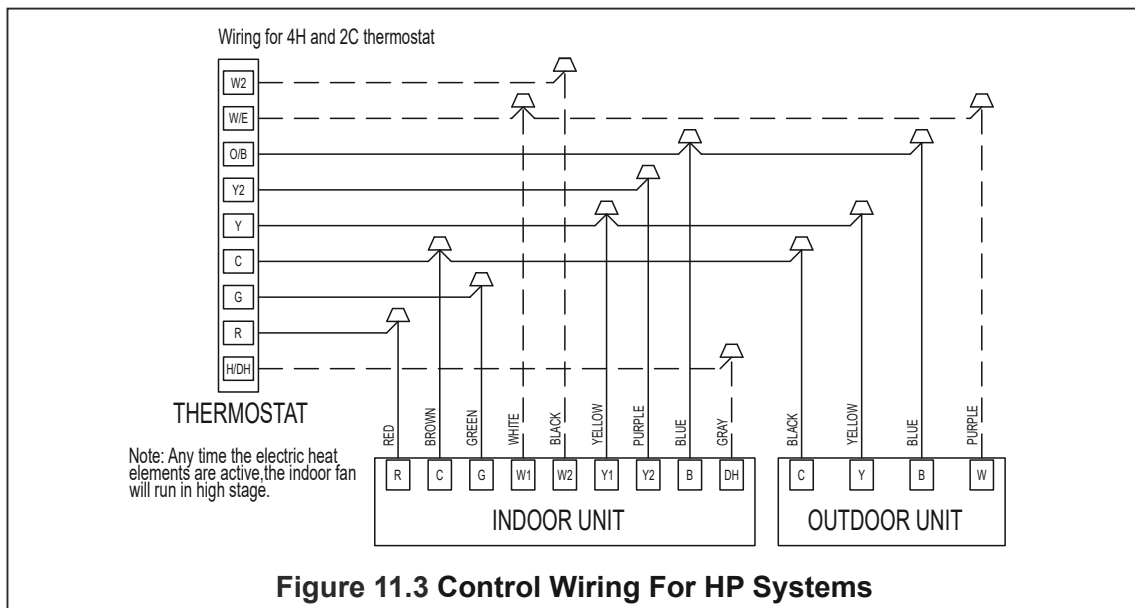
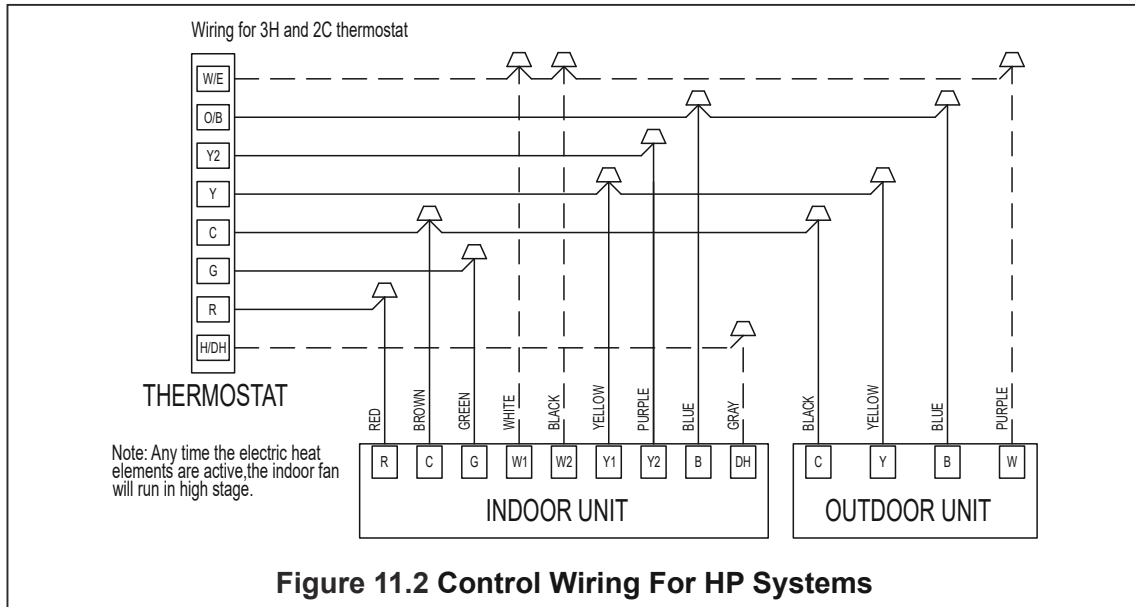


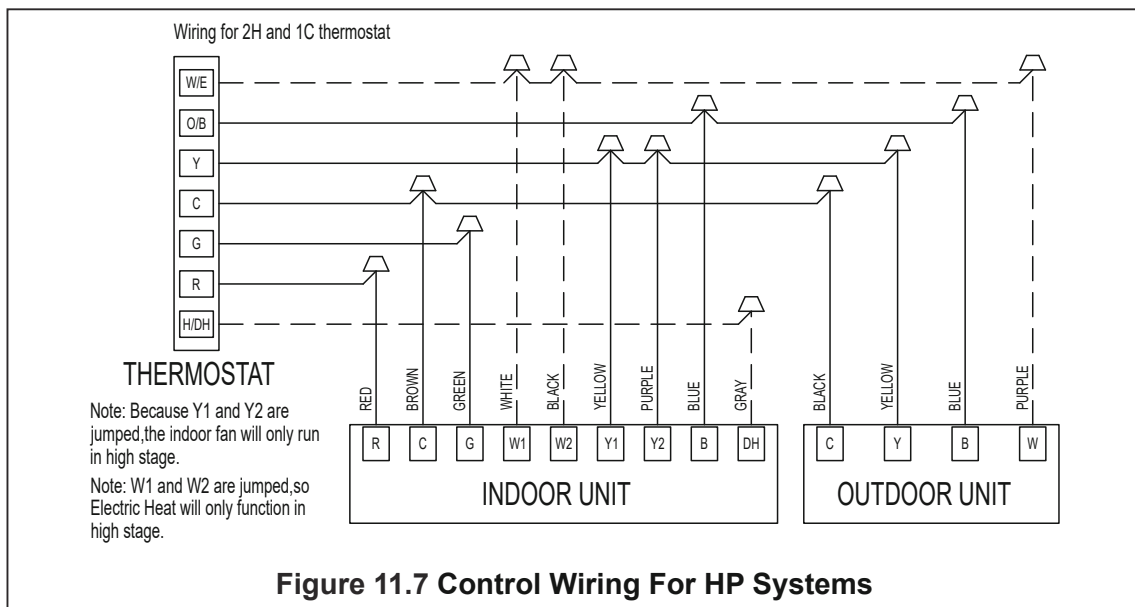
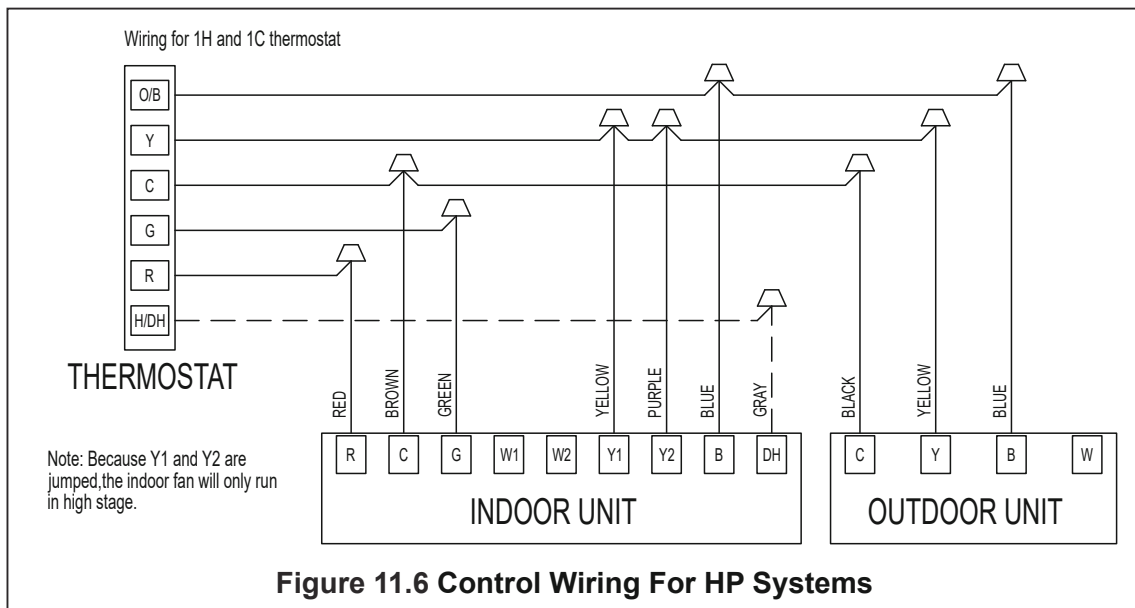
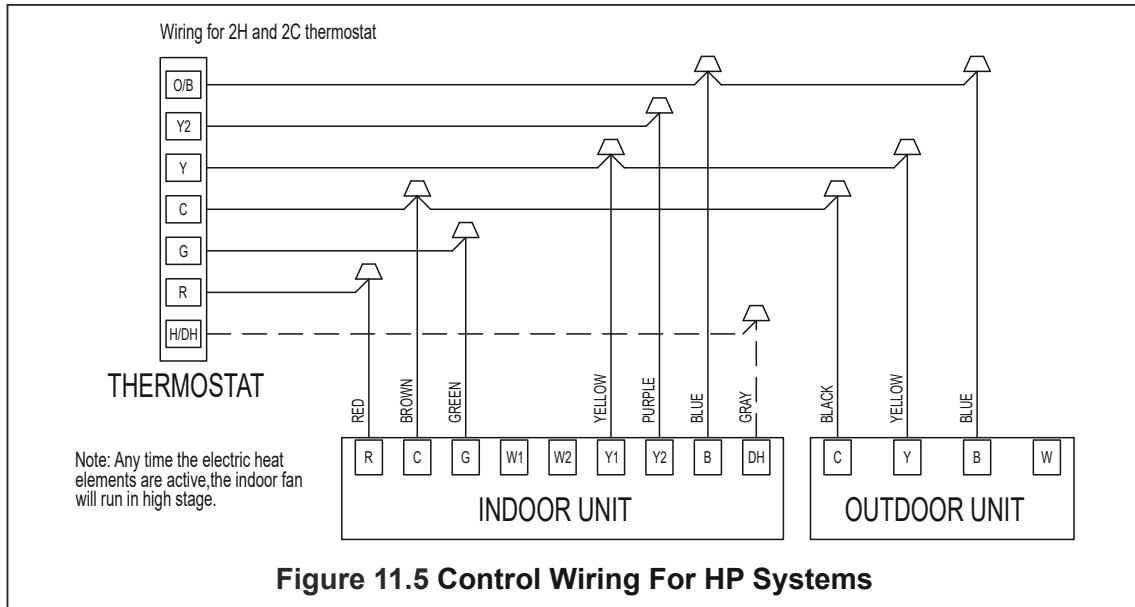
The dotted line in the following thermostat wiring diagram indicates optional wiring (wiring for passive dehumidification and/or electric heating). For the wiring of the thermostat, please refer to the user manual of the thermostat.



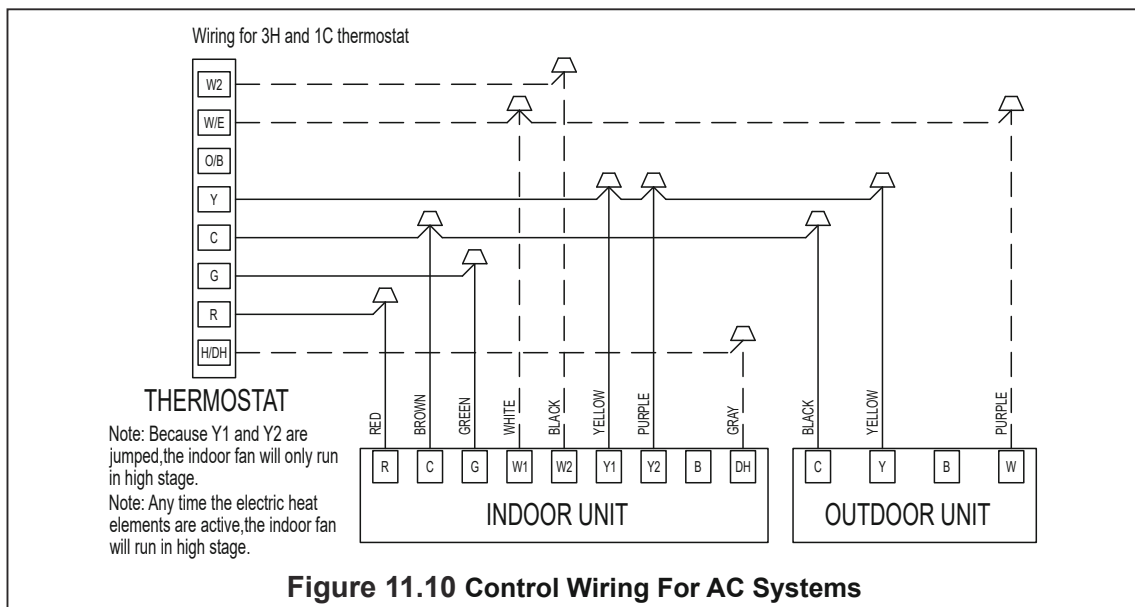
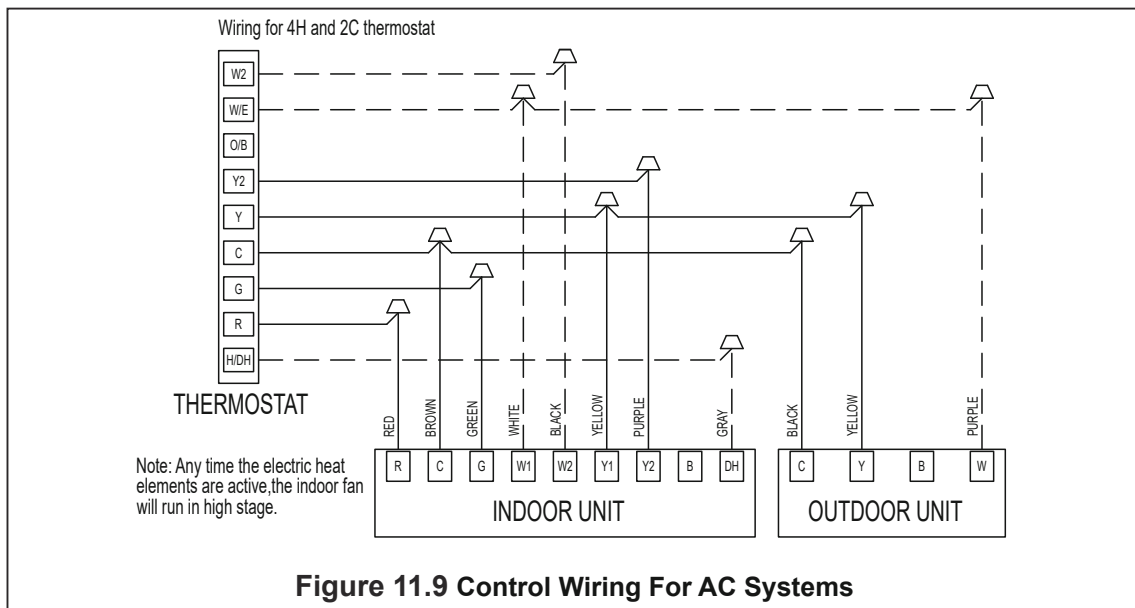
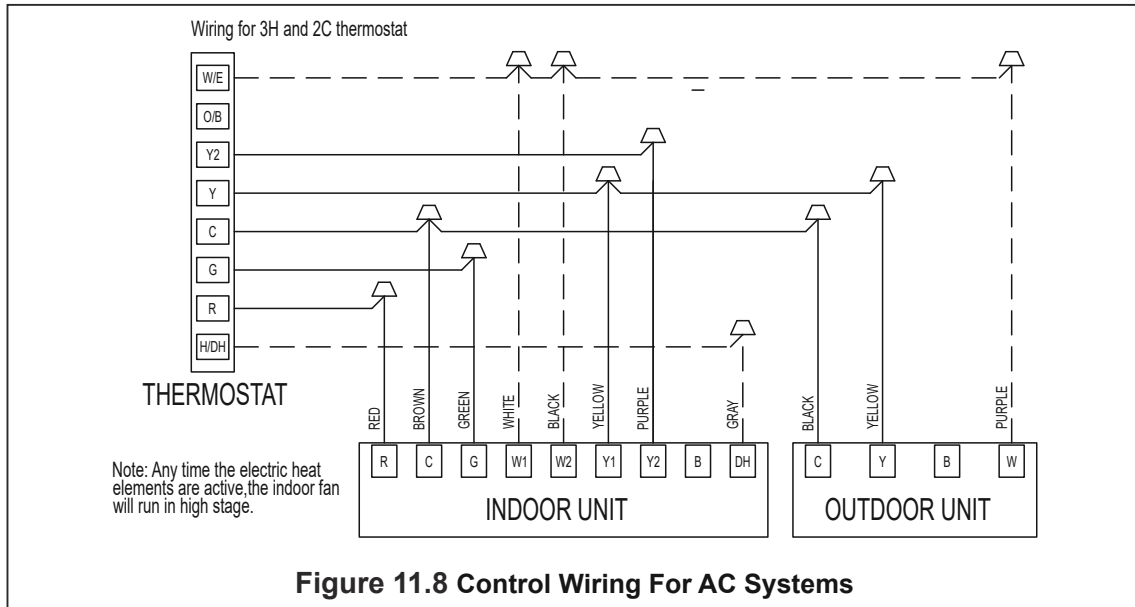
Terminal B will be connected with the thermostat (O/B) wiring. The reversing valve is energized during heating.

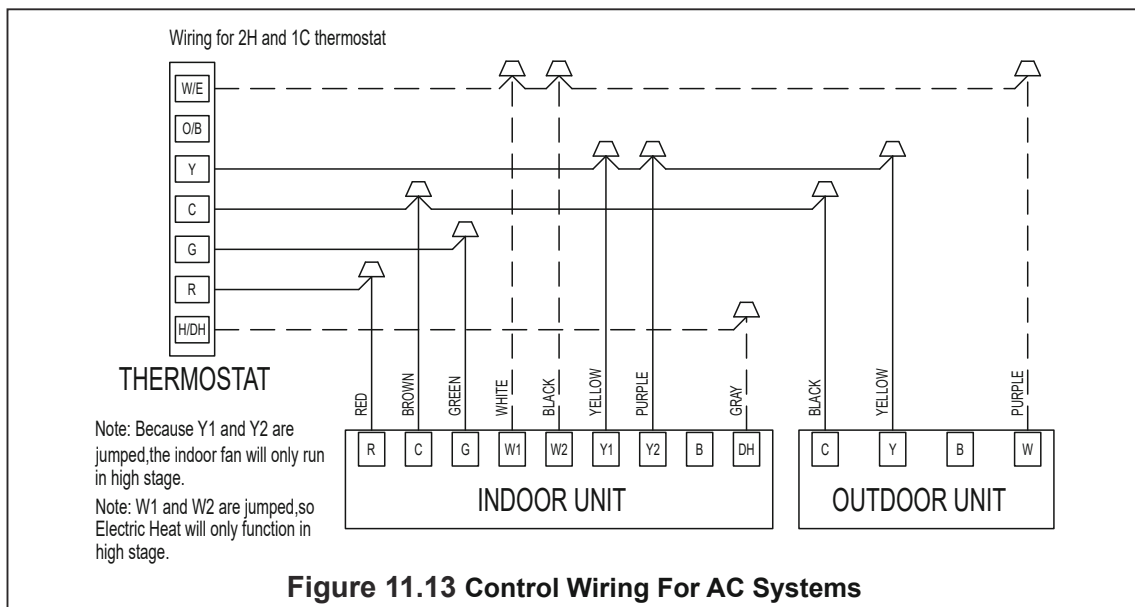
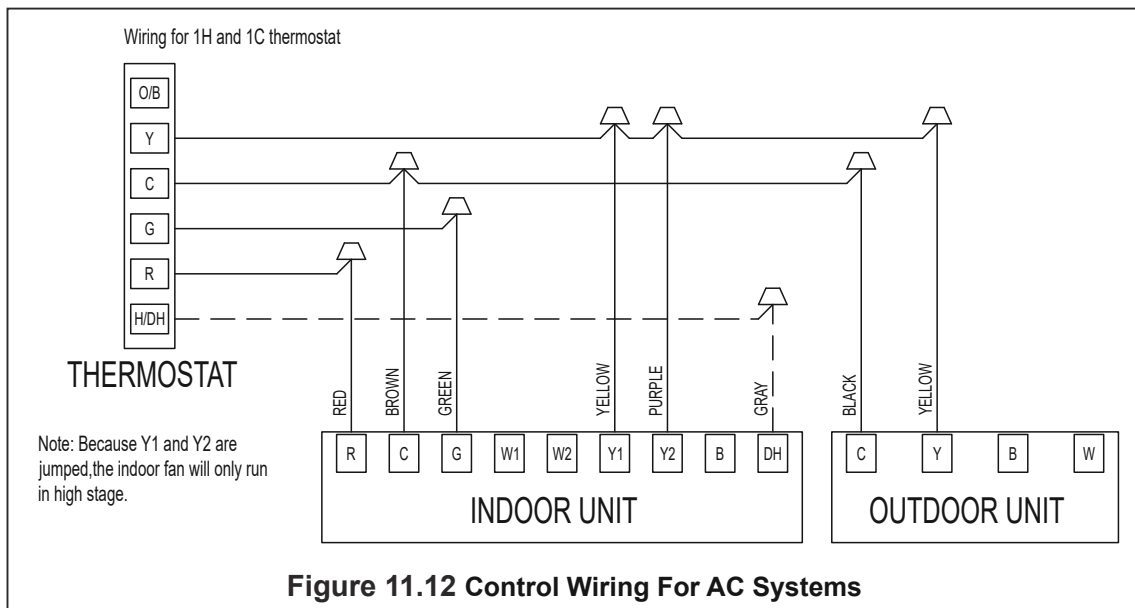
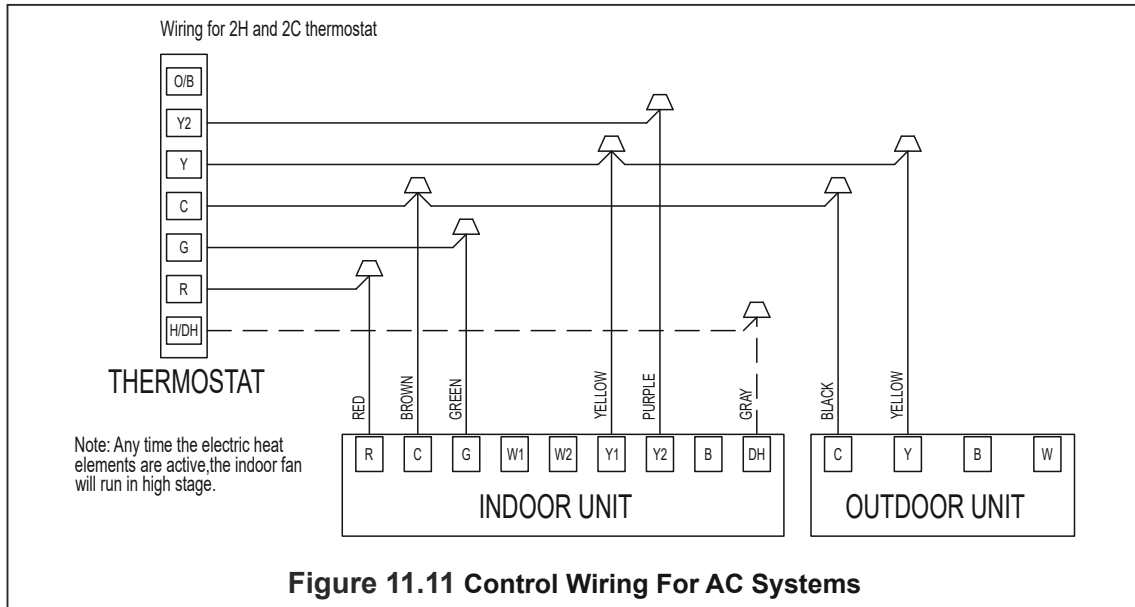
---











## 12. Electrical-High Voltage

### 12.1 High Voltage Power Supply

#### Warning: Live Electrical Parts



- During the installation, testing, maintenance and troubleshooting of this product, it may be necessary to use live electrical parts. Failure to observe all electrical safety precautions when exposed to live electrical parts may result in death or serious injury.

The high-voltage power supply must match the nameplate of the unit (208/230V, 1PH, 60Hz).



Power supply wiring must comply with national, state and local regulations.

Follow the instructions of the unit wiring diagram located inside the access panel of the control box, and refer to the wiring diagram in this manual.

### 12.2 High Voltage Isolating Switch

Install a separate disconnect switch on the outdoor unit.

High-voltage wiring must use flexible electrical conduit supplied on site.

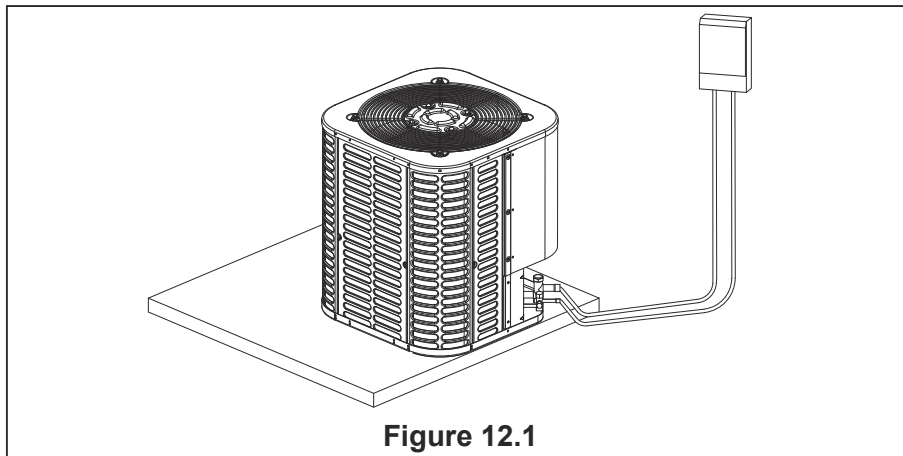


Figure 12.1

### 12.3 High Voltage Grounding

Ground the outdoor unit according to the requirements of national, state, and local regulations.

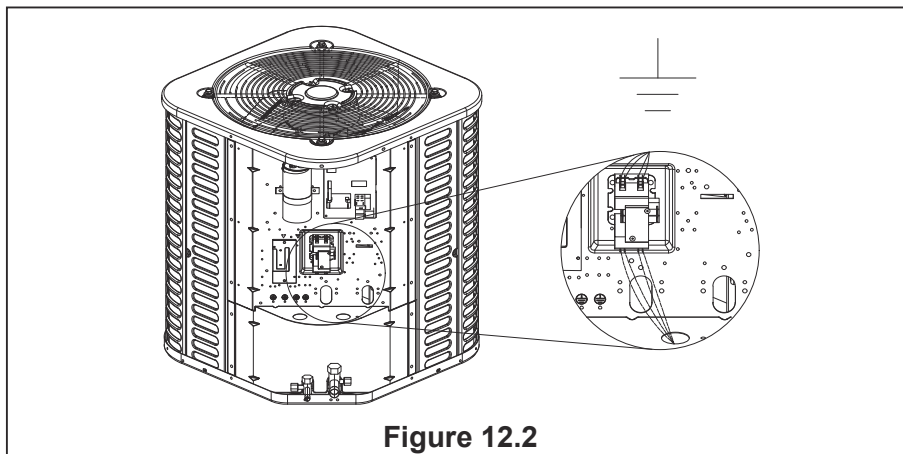


Figure 12.2

# 13. Start

## 13.1 System Startup

1. Make sure that parts 7, 8, 9, 10, 11, and 12 have been completed.
2. Set the system thermostat to off.

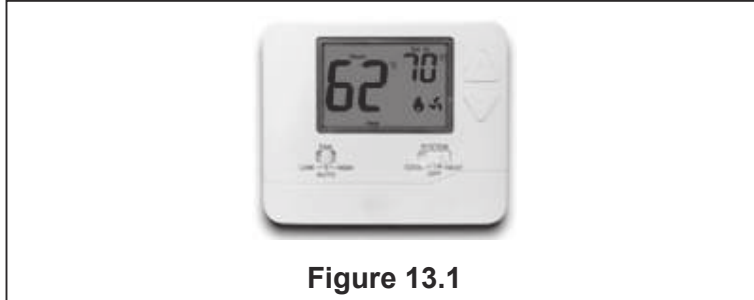


Figure 13.1

3. Turn on the disconnect switch and turn on the power to the indoor unit and outdoor unit.

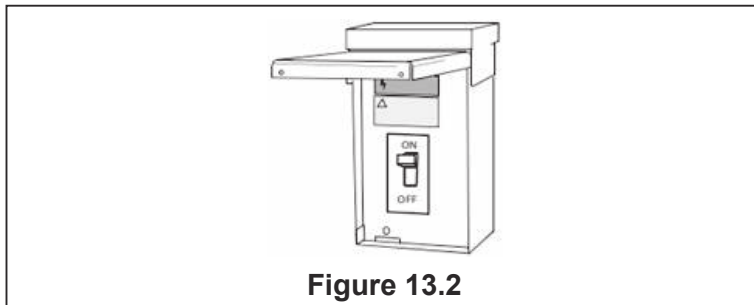


Figure 13.2

4. When installing the unit for the first time, if the compressor crankshaft heater is used and the outdoor ambient temperature is lower than 70°F, wait one (1) hour before starting the unit.

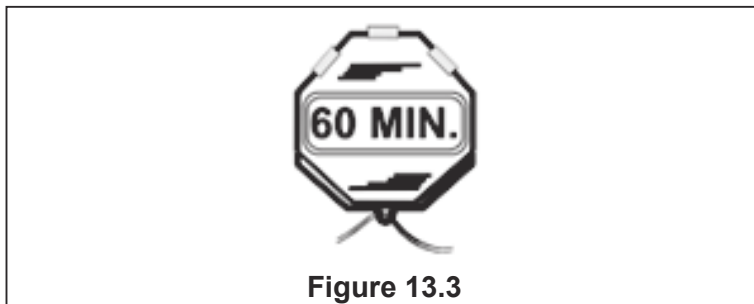


Figure 13.3

5. Set the system thermostat to ON.

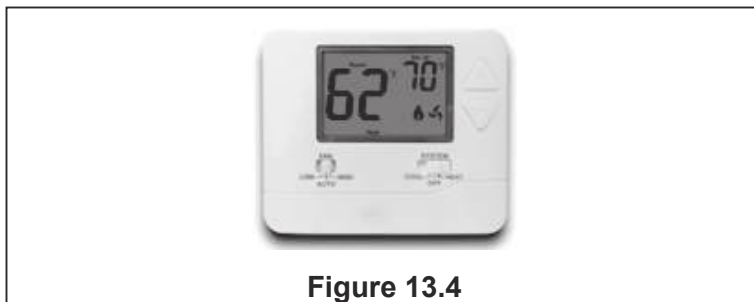


Figure 13.4

# 14. System Refrigerant Charging Regulation

## 14.1 Charging: Weighing Method

During the initial installation, or when the refrigerant quantity of the updated system is charged, the weighing method is used. It must be used when there is no power supply at the site of the unit or the operating conditions (indoor/outdoor temperature) are not within the range verified by Subcooling charging method. All models have a charge factor of 0.6 oz / ft for refrigerant pipe length.



For a 25-ft standard size interconnecting liquid pipe, the factory refrigerant charge of the outdoor unit is sufficient.

### New installation-Calculate the charging amount of connecting pipes larger than 25 ft.

1. Total length of pipeline (ft) = \_\_\_\_\_(a)
2. Standard piping setup (ft) =25 (b)
3. (a) minus (b) = \_\_\_\_\_ (c)
4. Refrigerant multiplier = 0.6 oz/ft (d)
5. Additional refrigerant quantity (c\*d) = \_\_\_\_\_(e)\*

\* If the line set is less than 25 feet, e=0

### Closed system maintenance-calculate the total filling amount of the system.

1. Total length of pipeline (ft) = \_\_\_\_\_(a)
2. Standard piping setup (ft) =25 (b)
3. (a) minus (b) = \_\_\_\_\_ (c)
4. Refrigerant multiplier = 0.6 oz/ft (d)
5. Additional refrigerant quantity (c\*d)= \_\_\_\_\_(e) \*
6. Factory filling quantity (nameplate)= \_\_\_\_\_(f)
7. Total system charge (e +f) = \_\_\_\_\_

\* If the line set is less than 25 feet, e =0



The only mode approved for verifying system charging is when the unit is in "forced cooling mode". The outdoor temperature must be between 55°F and 120°F, and the indoor temperature should be between 70°F and 80°F.

## 14.2 Subcooling Charging and Refrigerant Quantity Adjustment in Cooling Mode

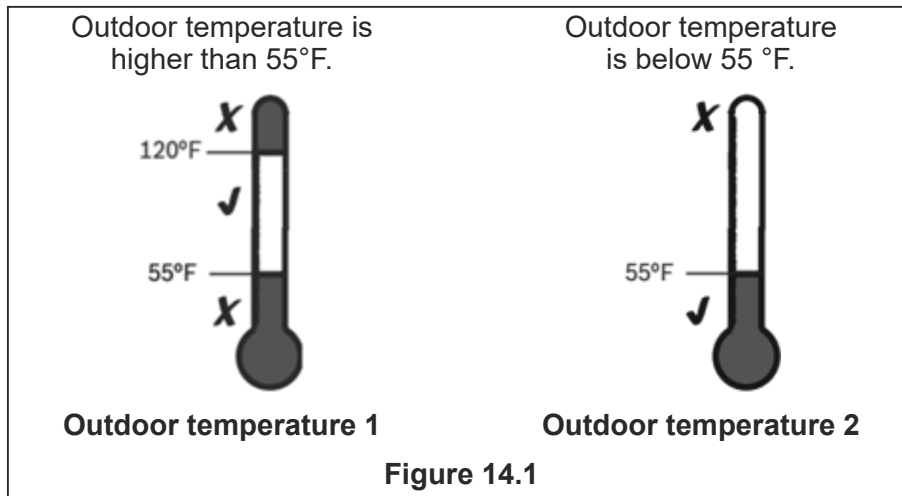
1. Check the outdoor ambient temperature.

Subcooling (cooling mode) is the only recommended charging method when the outdoor ambient temperature is higher than 55°F.

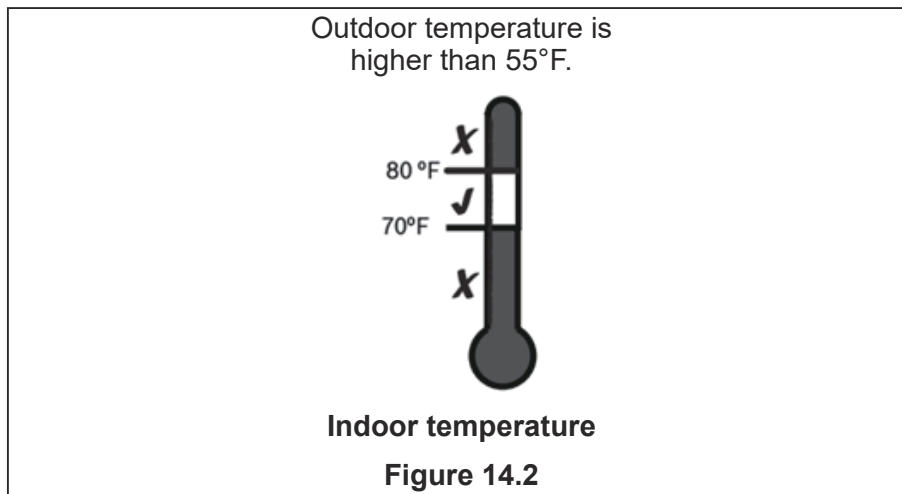
For outdoor ambient temperature below 55°F, use the weighing charging method.



When the outdoor ambient temperature is higher than 55°F, be sure to return in spring or summer, so as to accurately charge the system in cooling mode.



For best results, the indoor temperature should be kept between 70°F and 80°F during installation.



2. Make sure that parts 7, 8, 9, 10, 11, 12 and 13 have been completed.

# 15. System Operation and Troubleshooting

## 15.1 Control Logic Description

- The system uses universal 24V control.

## 15.2 Sensors

- T3- Outdoor unit coil temperature (Table 15.3)
- T4- Ambient temperature (Table 15.3)
- T5- Compressor exhaust temperature (Table 15.4)
- HP- High pressure switch
- LP- Low pressure switch

## 15.3 Description of Defrosting

- Outdoor unit W terminal will output 24V signal during defrost mode.
- Unit will run defrost mode in the following conditions:
  - 1) Unit run in heating mode
  - 2) Compressor is running.
  - 3) The defrost mode and cycle time is in relation to SW1-1 and SW1-2 dial switch

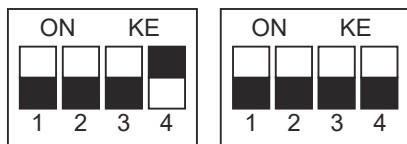


Figure 15.1

Table 15.1

Dial switch	SW1-1	SW1-2
OFF	Defrost mode 1	Cycle time: 60 min
ON	Defrost mode 2	Cycle time: 30 min

① When SW1-1 is OFF, the unit will run defrost mode 1 when it meets any of the following conditions:

Condition 1: When compressor starts, the unit will record minimum T3 which is named T30, and minimum T4 which is named T40 during compressor runs 10-15mins.

When outdoor unit meets the following conditions, the unit will run defrost mode:

- When  $T3 < 0$ , and compressor runs for 40mins;
- Unit calculate  $\Delta T4 = T4 - T40$  (If  $\Delta T4 \leq 2$ , unit will result  $\Delta T4 = 0$ ), and  $T3 + 2 < (T30 + \Delta T4)$  keep 30s.

Condition 2: When  $T3 < 0$ , and compressor run for 40mins, and  $T3 < 5^\circ\text{F}$  ( $-15^\circ\text{C}$ ), unit will defrost.

② When SW1-1 is ON, unit will run defrost mode 1 when it meets any of the following conditions:

Condition 1:

- SW1-2 is ON, and the compressor is running, when  $T3 < 5^\circ\text{F}$  ( $-1^\circ\text{C}$ ) and keep 30 mins, the unit will run defrost.
- SW1-2 is OFF, and the compressor is running, when  $T3 < 5^\circ\text{F}$  ( $-1^\circ\text{C}$ ) and keep 60 mins, the unit will run defrost.

Condition 2: When the unit power is on, and compressor is starting for the first time, and  $T3 < 28.4^\circ\text{F}$  ( $-2^\circ\text{C}$ ), the unit will run defrost.

Condition 3: When unit is on standby for 2 hours, and  $T3 < 28.4^\circ\text{F}$  ( $-2^\circ\text{C}$ ), unit will run defrost.

Quit defrost condition:

① When SW1-1 is OFF, unit will quit defrost when it meets any below condition.

Condition 1: Defrost time lasts 10 mins. per cycle.

Condition 2:  $T3 \geq 50^\circ\text{F}$  ( $10^\circ\text{C}$ )

① When SW1-1 is ON, unit will quit defrost when it meets any below condition.

Condition 1: Defrost time lasts 10 mins. per cycle.

Condition 2:  $T4 \geq 28.4^\circ\text{F}$  ( $-2^\circ\text{C}$ ) and  $T3 \geq 77^\circ\text{F}$  ( $25^\circ\text{C}$ )

Condition 3: Compressor stops

Condition 4:  $T4 < 28.4^\circ\text{F}$  ( $-2^\circ\text{C}$ ),  $T3 \geq 77^\circ\text{F}$  ( $25^\circ\text{C}$ ) and keep 60s.

## 15.4 Compressor Crankshaft Heater Control Function

The crankshaft heater logic is below:

### ① Crankshaft heater ON condition:

When the unit meets any of the following conditions, the crankshaft heater will turn ON:

Condition 1: Meet 3 of the following conditions at the same time:

- T5 < 73.4°F (23°C) or T5 sensor is abnormal.
- Outdoor unit is in standby mode, and T4 was lower 50°F (10°C) before.
- Outdoor unit stop time ≥ 4h (or 3.5h when unit power on first time).

Condition 2:

- Outdoor unit power is on, and T5 < 73.4°F (23°C);
- Outdoor unit is in defrost mode, and T5 < 73.4°F (23°C)。

### ② Crankshaft heater OFF condition

T5 ≥ 82.4°F (28°C) and no T5 error

## 15.5 Four-way Valve Operating Condition

Four-way valve will power on in heating mode, and power off in cooling mode.

## 15.6 LED display function of the outdoor unit main PCB and fault table

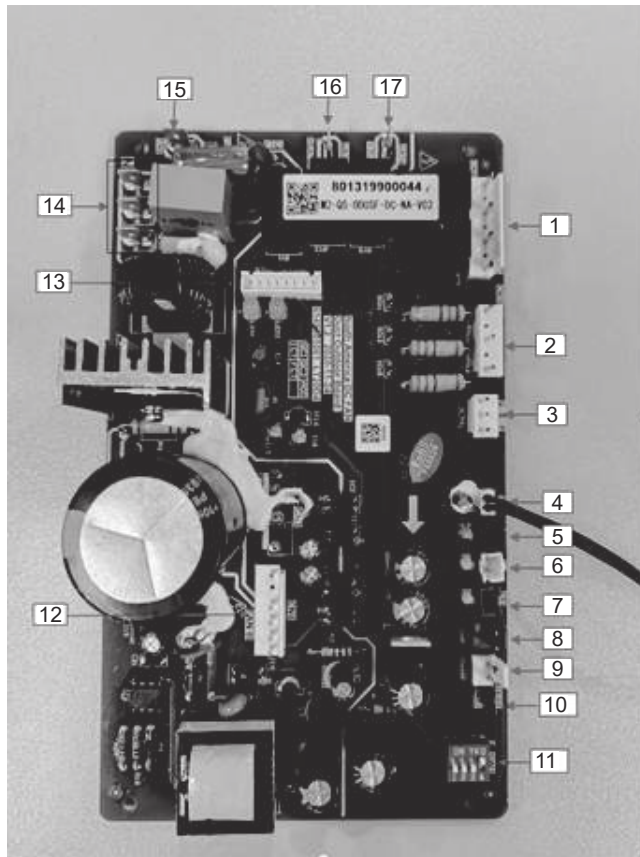
Table 15.2

Display Content:	Content	Description
Normal Display: Yellow Light OFF	Green light flash slow	Unit standby
	Green light ON	Unit is running
Display Content:	T3 temperature sensor error	Yellow light flash 1 time for every 8s
	T4 temperature sensor error	Yellow light flash 2 time for every 8s
	T5 temperature sensor error	Yellow light flash 3 time for every 8s
	Low pressure protection	Yellow light flash 4 time for every 8s
	High pressure protection	Yellow light flash 5 time for every 8s
	T3 high temperature protection	Yellow light flash 6 time for every 8s
	T5 high temperature protection	Yellow light flash 7 time for every 8s
	Fan motor feedback error	Yellow light flash 8 times for every 8s (Only for DC fan motor)
Outdoor unit error and locked: Green light ON, Yellow light flash.	Low pressure protection occur 6 times within 60 mins.	Yellow light flash 4 times for every 8s
	High pressure protection occur 6 times within 60 mins.	Yellow light flash 5 times for every 8s
	T3 high temperature protection occur 6 times within 60 mins.	Yellow light flash 6 times for every 8s
	T5 high temperature protection occur 3 times within 20 mins.	Yellow light flash 7 times for every 8s



## 15.7 Outdoor Unit Main PCB Description

### Outdoor Unit Main PCB



Num	Functional Description
1	W COMP R C terminal (24V)
2	W1 B Y terminal (24V)
3	Reserved
4	T3 temperature sensor terminal
5	T4 temperature sensor terminal
6	T5 temperature sensor terminal
7	Reserved
8	Low pressure switch terminal
9	Low pressure switch terminal
10	TEST terminal
11	Dial switch
12	DC fan motor terminal
13	DEBUG terminal
14	Power input N terminal
15	Power input L terminal
16	Crankshaft heater terminal
17	Four-way valve terminal

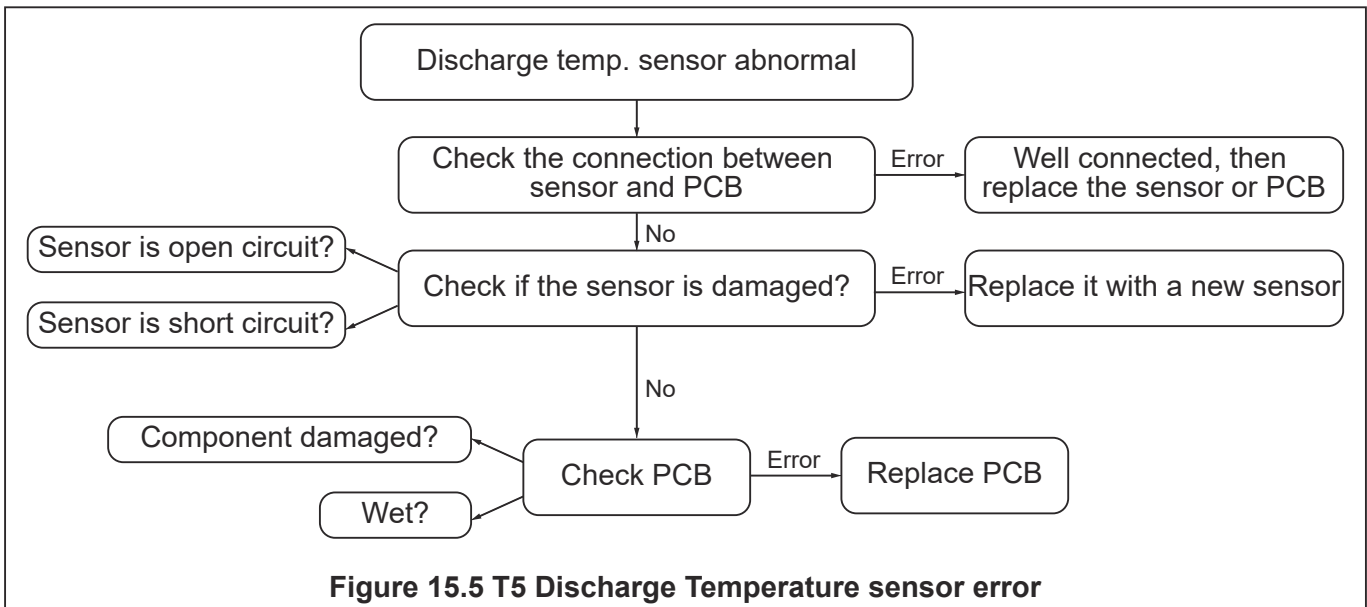
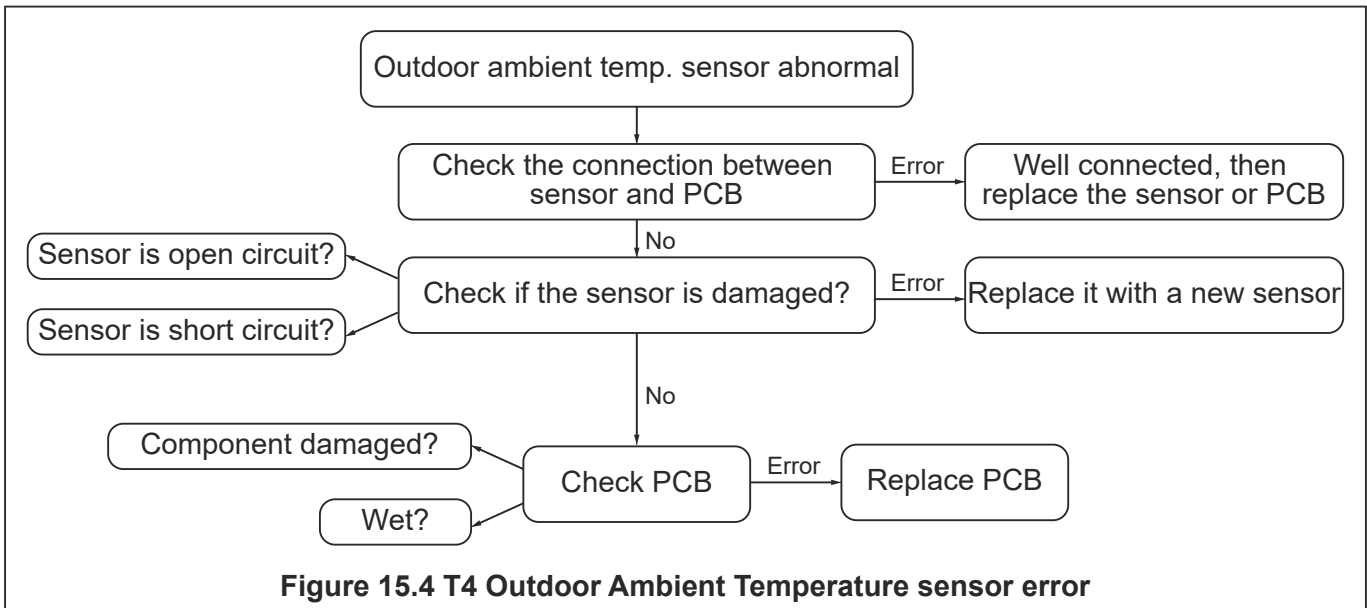
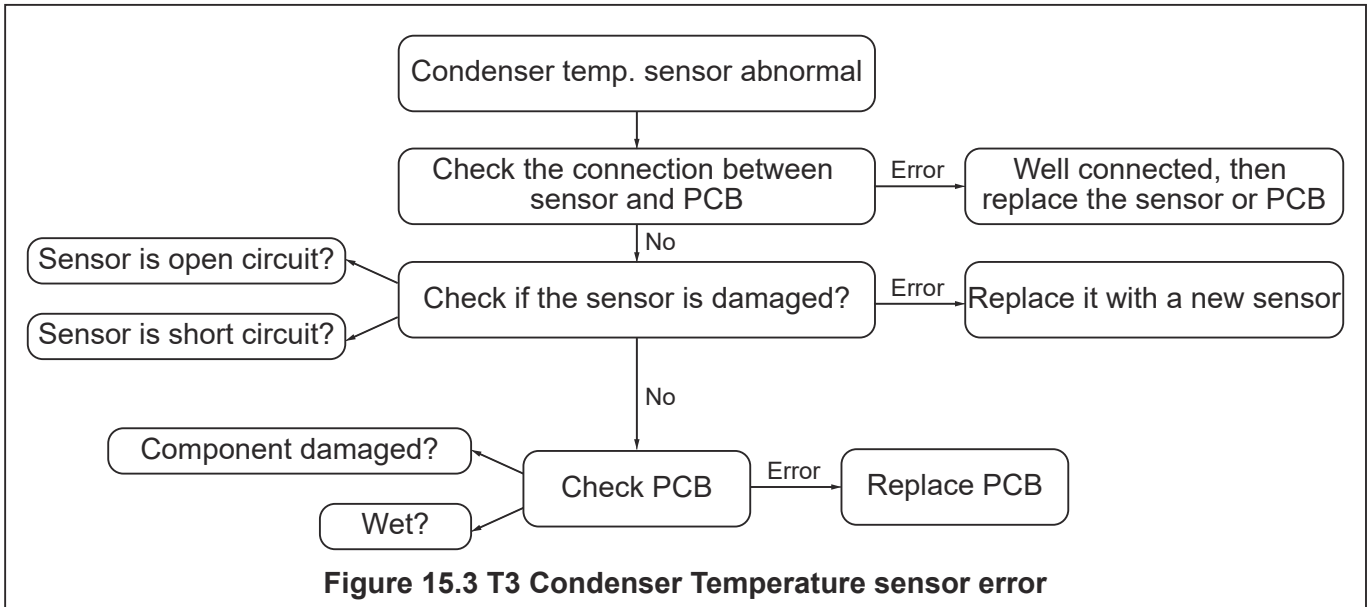
Figure 15.2

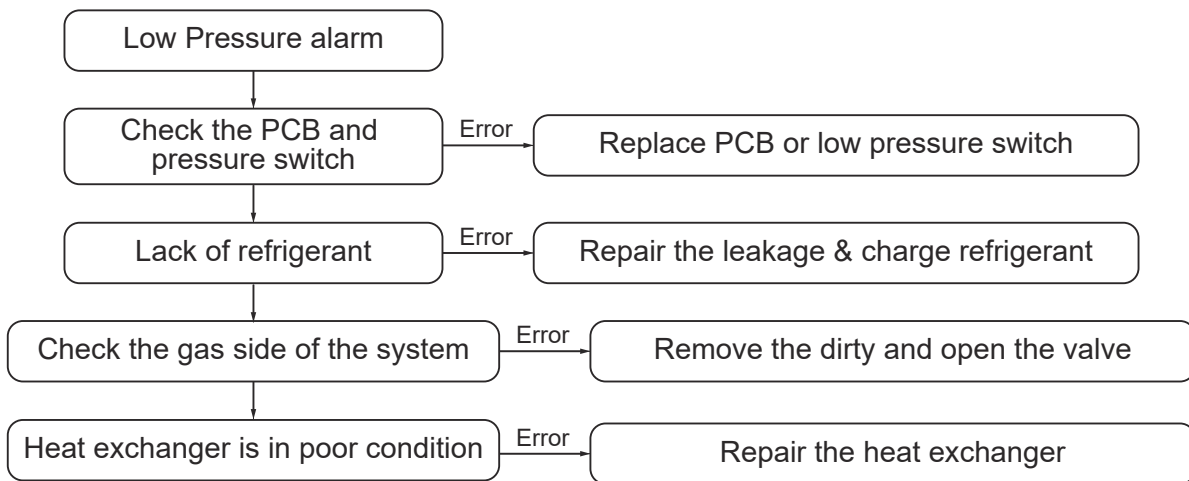
## 15.8 Troubleshooting of Fault Codes



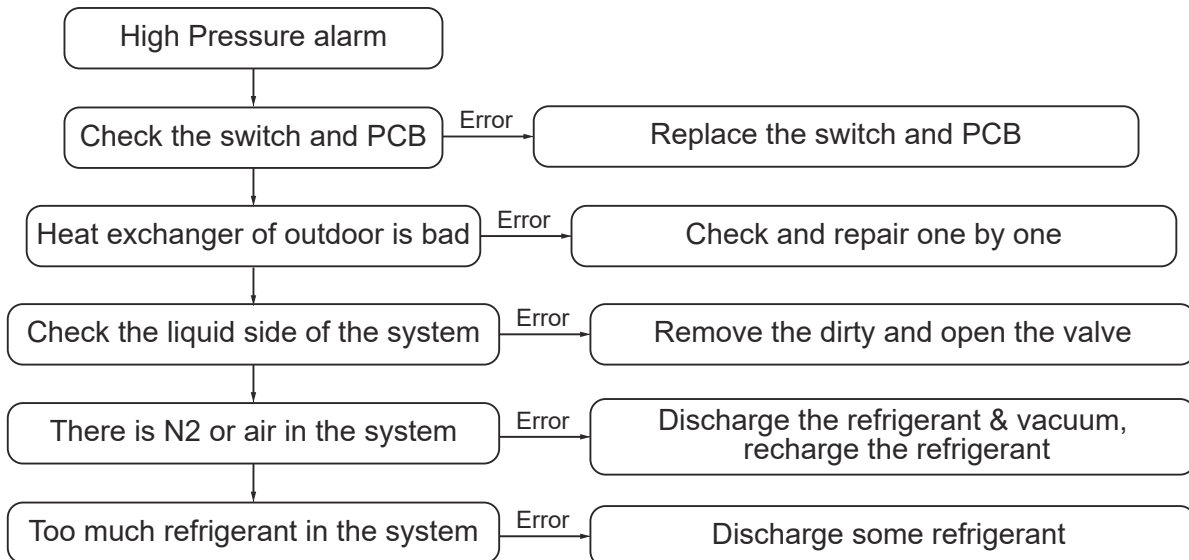
### Warning: Dangerous Voltage

- When measuring the resistance, make sure that the power to the unit is turned off and wait for 3 minutes before measuring.

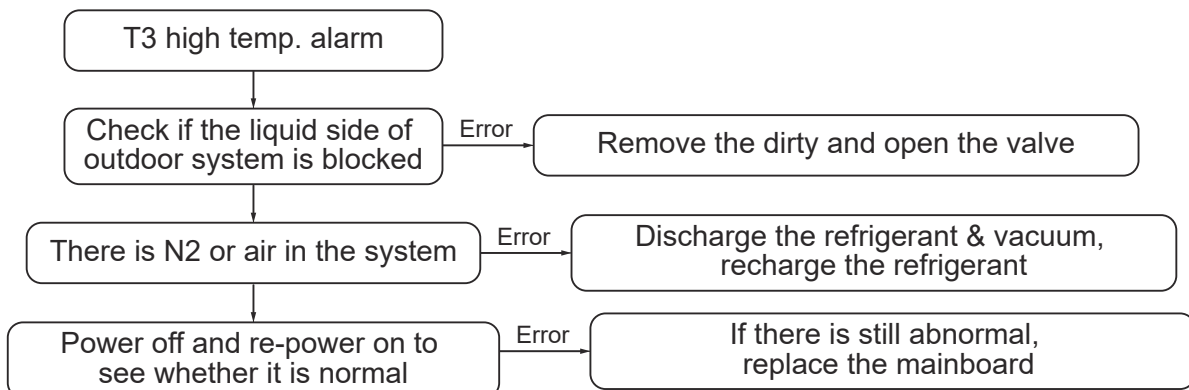




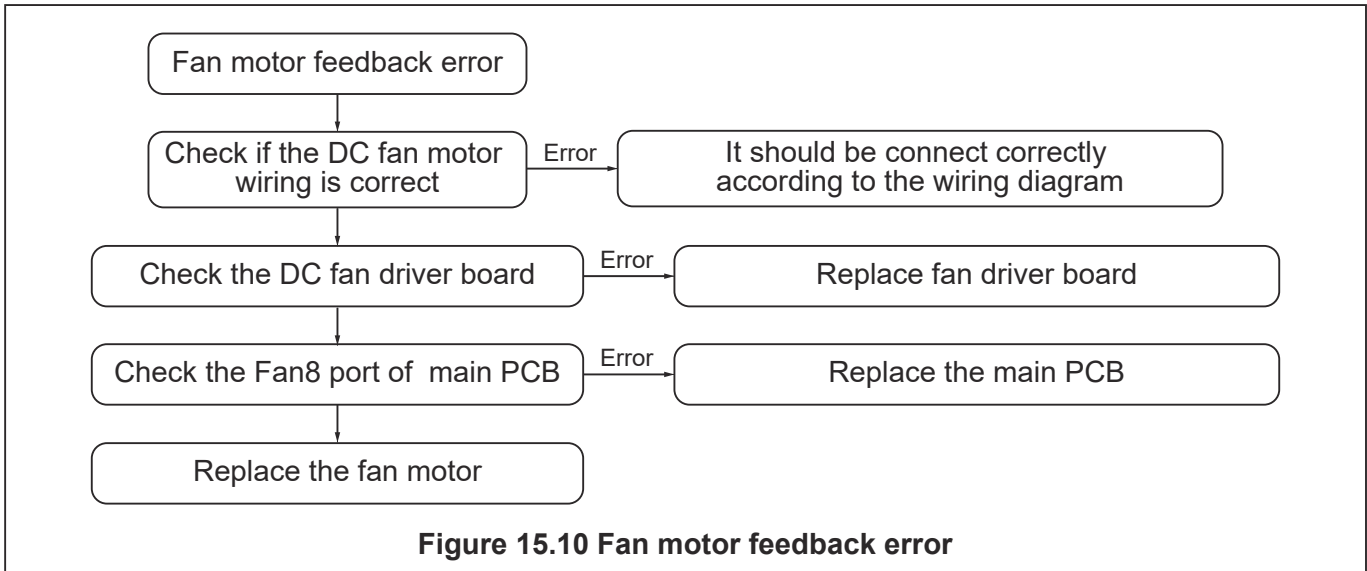
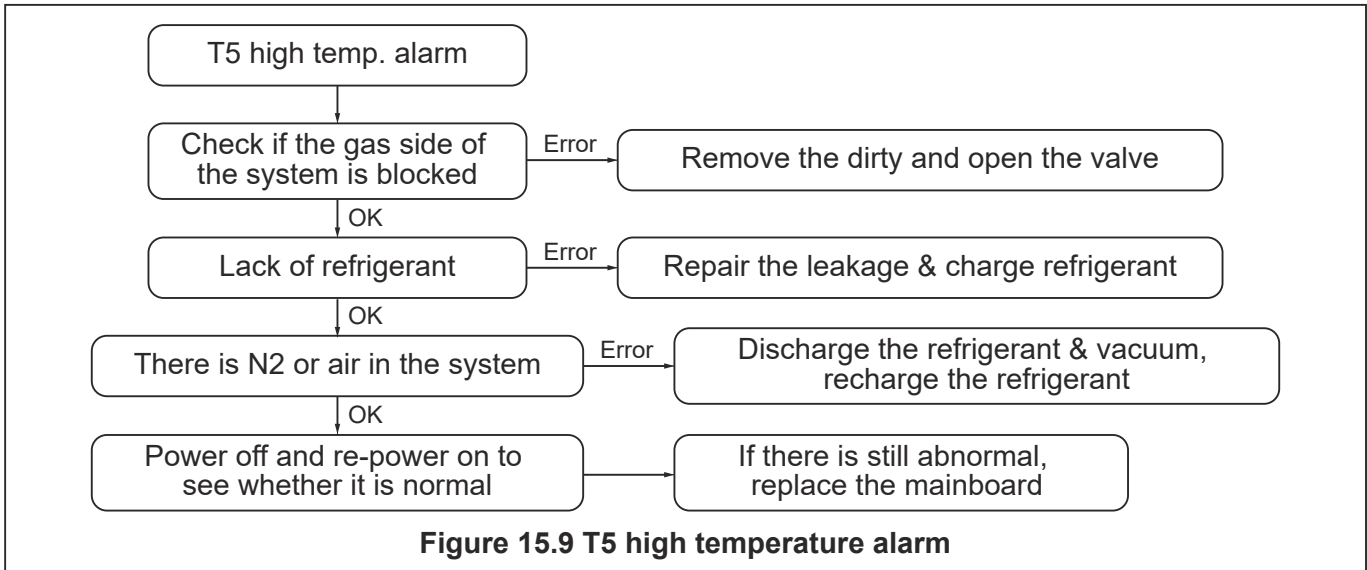
**Figure 15.6 Low Pressure alarm**



**Figure 15.7 High Pressure alarm**



**Figure 15.8 T3 high temperature alarm**



## 15.9 Temperature-Resistance Relationship Table (For T3 and T4 Sensors)

Table 15.3 for T3, T4

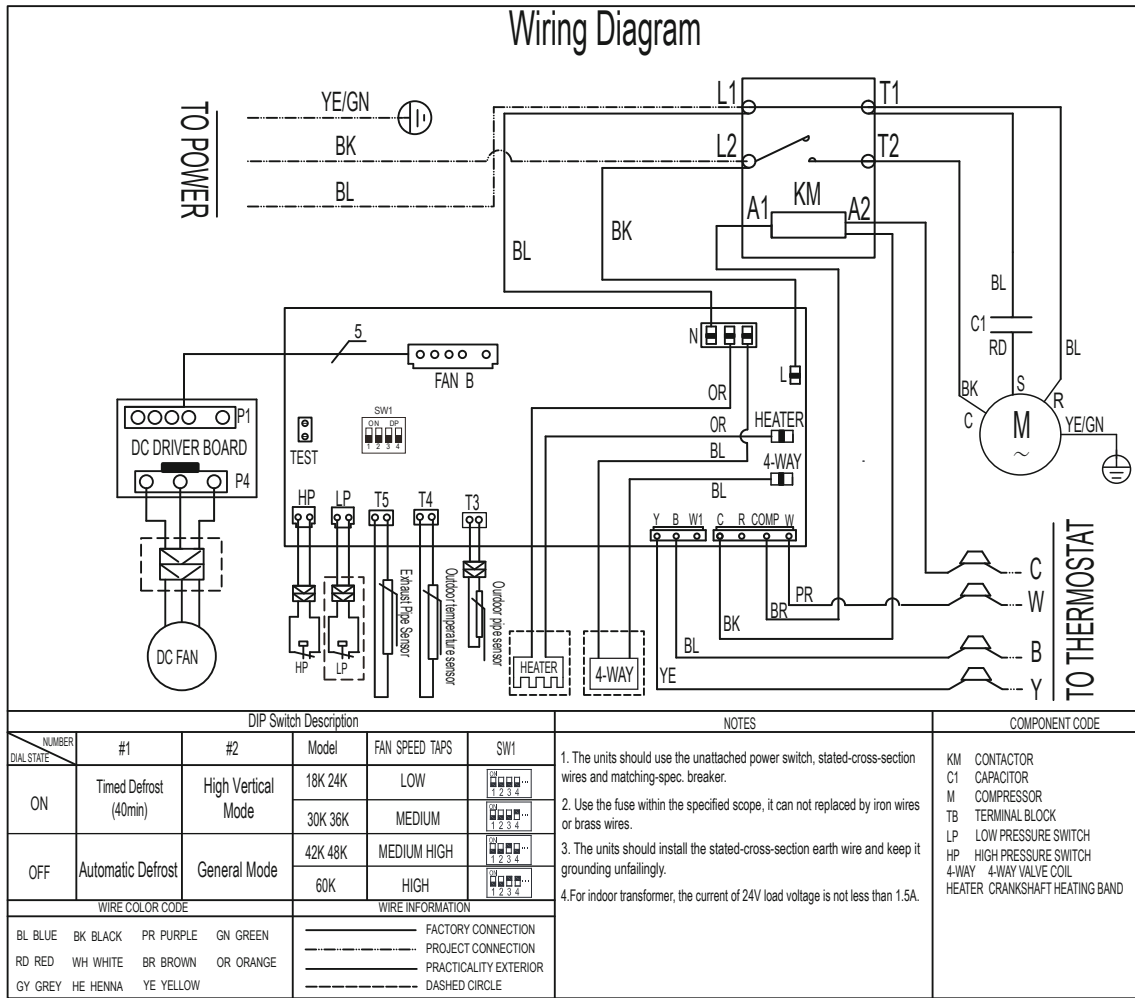
Temperature F	Temperature C	Electric Resistance kΩ	Volt DC	Temperature F	Temperature C	Electric Resistance kΩ	Volt DC
-5	-20.6	33.367	0.57	90	32.2	3.865	2.63
0	-17.8	29.227	0.64	95	35.0	3.508	2.75
5	-15.0	25.657	0.72	100	37.8	3.187	2.87
10	-12.2	22.595	0.80	105	40.6	2.900	2.99
15	-9.4	19.942	0.89	110	43.3	2.652	3.09
20	-6.7	17.697	0.98	115	46.1	2.421	3.20
25	-3.9	15.673	1.08	120	48.9	2.214	3.30
30	-1.1	13.917	1.18	125	51.7	2.025	3.40
40	4.4	11.060	1.40	130	54.4	1.861	3.49
45	7.2	9.867	1.52	135	57.2	1.706	3.58
50	10.0	8.823	1.64	140	60.0	1.567	3.66
55	12.8	7.884	1.76	145	62.8	1.442	3.74
60	15.6	7.101	1.89	150	65.6	1.327	3.82
65	18.3	6.409	2.01	155	68.3	1.226	3.89
70	21.1	5.767	2.14	160	71.1	1.132	3.96
75	23.9	5.150	2.28	165	73.9	1.046	4.02
80	26.7	4.700	2.39	170	76.7	0.967	4.08
85	29.4	4.266	2.51				

## 15.10 Temperature-resistance relationship table (for T5 sensor)

Table 15.4 for T5

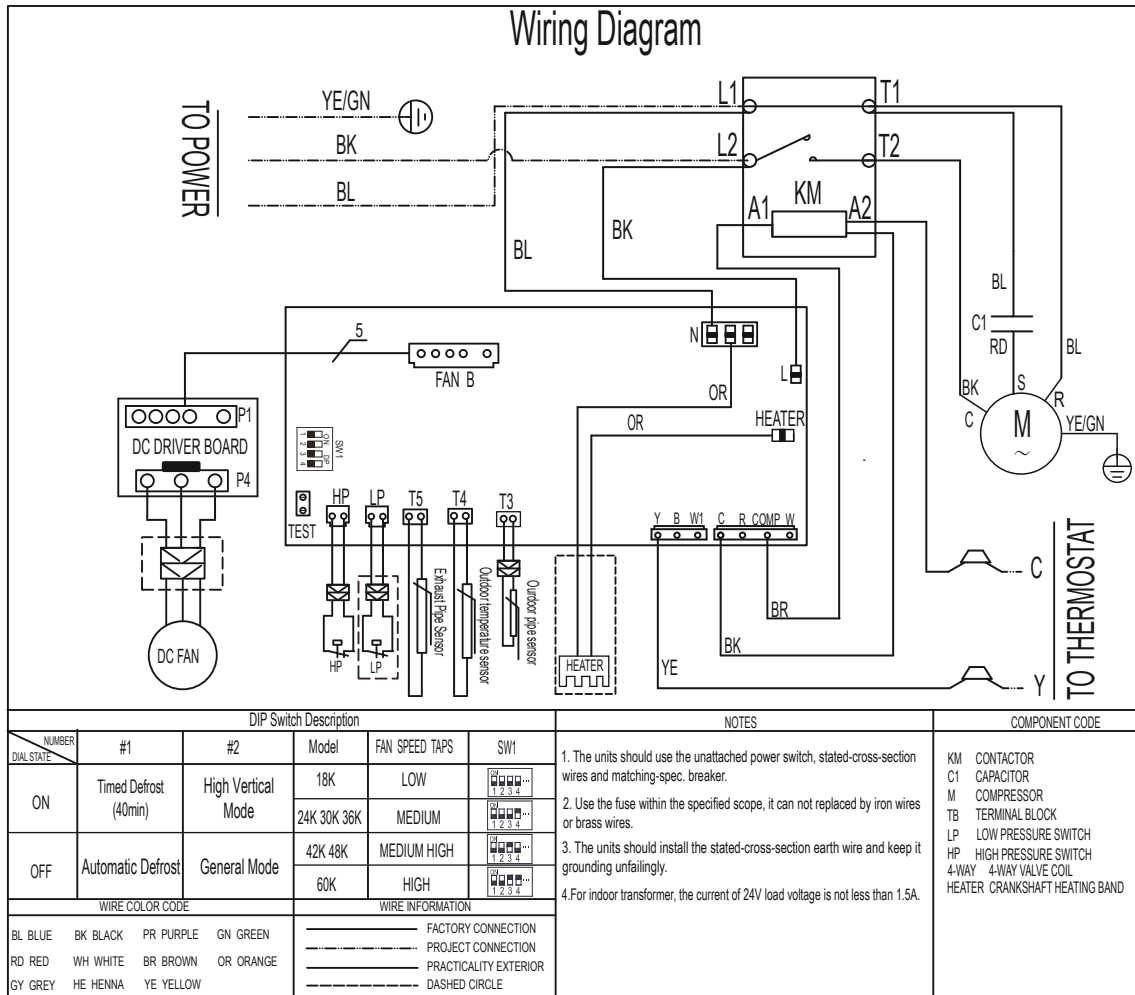
Temperature F	Temperature C	Electric Resistance kΩ	Volt DC	Temperature F	Temperature C	Electric Resistance kΩ	Volt DC
-5	-20.6	496.38	0.08	140	60.0	12.348	1.97
0	-17.8	422.97	0.09	145	62.8	11.164	2.10
5	-15.0	361.35	0.11	150	65.6	10.106	2.22
10	-12.2	309.74	0.13	155	68.3	9.193	2.34
15	-9.4	266.152	0.15	160	71.1	8.344	2.46
20	-6.7	230.462	0.17	165	73.9	7.585	2.58
25	-3.9	198.968	0.19	170	76.7	6.904	2.69
30	-1.1	172.231	0.22	175	79.4	6.313	2.80
35	1.7	149.467	0.26	180	82.2	5.761	2.92
40	4.4	130.642	0.29	185	85.0	5.263	3.02
45	7.2	113.87	0.33	190	87.8	4.815	3.13
50	10.0	99.456	0.37	195	90.6	4.410	3.23
55	12.8	87.095	0.42	200	93.3	4.057	3.33
60	15.6	76.425	0.48	205	96.1	3.724	3.42
65	18.3	67.501	0.53	210	98.9	3.423	3.51
70	21.1	59.457	0.60	215	101.7	3.149	3.60
75	23.9	52.489	0.67	220	104.4	2.910	3.67
80	26.7	46.429	0.74	225	107.2	2.689	3.75
85	29.4	41.322	0.82	230	110	2.476	3.82
90	32.2	36.682	0.90	235	112.8	2.288	3.89
95	35.0	32.619	0.99	240	115.6	2.117	3.96
100	37.8	29.068	1.09	245	118.3	1.965	4.02
105	40.6	25.948	1.19	250	121.1	1.821	4.08
110	43.3	23.291	1.29	255	123.9	1.690	4.13
115	46.1	20.855	1.39	260	126.7	1.569	4.19
120	48.9	18.708	1.51	265	129.4	1.462	4.23
125	51.7	16.809	1.62	270	132.2	1.360	4.28
130	54.4	15.184	1.73	275	135.0	1.266	4.32
135	57.2	13.682	1.85	280	137.8	1.180	4.36

# 16 Wiring Diagram



**NOTE:** For reference only, the actual wiring diagram shall prevail

**Figure 16.1** Wiring Diagram for HP Systems



**NOTE:** For reference only, the actual wiring diagram shall prevail

**Figure 16.2 Wiring Diagram for AC Systems**

# 17 Cleaning and Maintenance

## 17.1 Cleaning Precautions



### Warning:

- Any cleaning of outdoor units can only be carried out by qualified maintenance personnel.
- Any unit maintenance can only be carried out by qualified maintenance personnel.



### Caution: Electric Shock

- Be sure to turn off the unit and disconnect the power supply before cleaning or maintenance.



### Note:

- Do not use chemicals or chemically treated cloth to clean the unit.
- Do not use benzene, paint thinner, polishing powder or other solvents to clean this unit.








### Caution:

- When removing the filter, avoid touching the metal parts inside the unit. Sharp metal edges can cause bodily harm.

## 17.2 Pre-Season Inspection and Maintenance

At the start of each heating or cooling season, do the following:

	Turn off the unit and disconnect the power supply.
  	Check for damaged wires & leaks.
	Make sure that all air inlets and outlets are not blocked.

**Table 17.1**





**MRCOOL®**

**COMFORT MADE SIMPLE**

# **PRODIRECT™ Series**

**Split System Heat Pump & Air Conditioner**

**13 -14 SEER 1.5-5 Tons Model**

**HHP140\* & HAC140\***

The design and specifications of this product and/or manual are subject to change without prior notice. Consult with the sales agency or manufacturer for details.