

## Mechanical Door Chime

### CHIME REPLACEMENT INSTALLATION

Note: Electrical work must be in accordance with national and local electrical codes. If in doubt, consult a qualified electrician.

1. Verify transformer power rating. Power must be supplied from a 24 Volt AC, 40 Watt transformer.
2. Remove cover from existing chime by gently using a flathead screwdriver on the side of the chime. If used, remove rubberbands and hardware packet from the chime base.
3. Label all wires before disconnecting. Using masking tape, mark each wire according to existing chime terminal markings.
  - "F" – Front Push Button Wire
  - "T" – Transformer Wire
  - "R" – Rear Push Button Wire\*
4. Disconnect all wires from existing chime.
5. Remove existing chime base from wall.
6. Determine proper chime base orientation. The chime cover style may determine orientation.
7. Route wires through wire entrance hole in new chime base.
8. Mount chime base to wall using screws provided.
9. Connect wire "F" to screw terminal marked "FRONT". Connect wire "T" to screw terminal marked "TRANS". Connect wire "R" to screw terminal marked "REAR" (See Figure 2).
10. Install chime cover (see "INSTALL CHIME COVER" section).

\*Note: Some installations may not include rear door push button.

**\*DO NOT** remove the foam piece that is above the plunger that makes the sound for the REAR or side door.

**\*It is not recommended to use a regular doorbell button with this 24V chime as most of these buttons are 16V. The button may burn out as a result.**

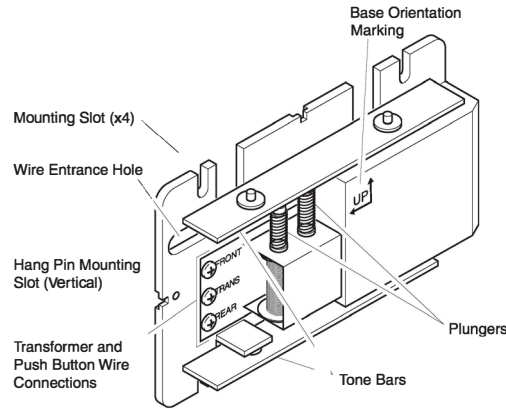

Figure 1 - Mechanical Chime Identification

Illustrations may vary from actual chime unit.

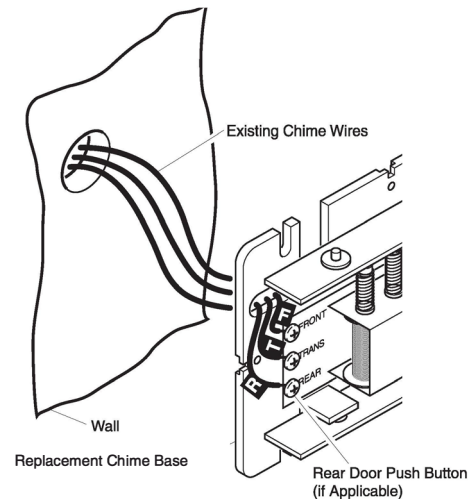

Figure 2 - Mechanical Chime Wiring

### INSTALL CHIME COVER

Place chime cover securely over base.

Snap-on cover: Apply pressure to the cover until it snaps into place (see Figure 3). Firmly grasp cover and pull to remove from base.

Note: Never use cleaners or polishes. Never use any fluids on the chime mechanism. Use dry cloth to clean chime cover and base.

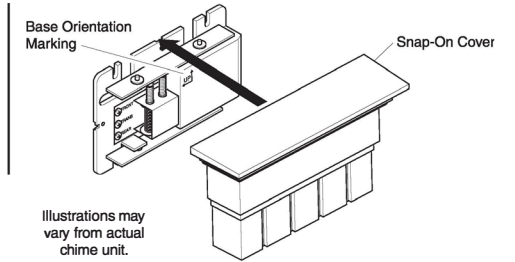
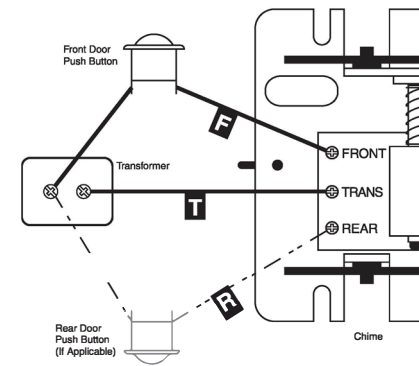

Figure 3 - Mounting Snap-On Cover



Chime System Wiring Diagram

### TROUBLESHOOTING

Chime does not sound:

- Check Chime: Disconnect wire from terminal marked "TRANS". Have someone operate push button at front door while you momentarily touch the "TRANS" wire to terminal marked "FRONT". You will see a small spark if push button, wiring, and transformer are operating properly. Repeat the steps for "REAR" terminal and rear push button. If wiring between transformer and push button(s) check out properly, replace chime.
- Check Transformer: Test transformer voltage output with a volt meter. If a volt meter is not available, momentarily touch the two low-voltage terminals with a screwdriver. You will see a small spark if transformer is operating properly. If no spark is evident, replace transformer.
- Check Push Button(s): Remove suspected push button from door frame, disconnect wire from terminals and touch bare wires together. If chime operates, push button is defective. Replace push button.

For more troubleshooting tips/FAQs, visit <https://www.newhousehardware.com/faq/>

Questions?  
Please contact us at [cs@adamaxinc.com](mailto:cs@adamaxinc.com)