

Job Name:	
Submitted By:	



Submittal Sheet For: YN009GMFI22RPE / RB009GMFILDHFD

Date _____
Ref. _____

Slim-Duct Concealed Inverter Heat Pump (0.75 Ton)

System Full Set Model: **RYB009GMFILDAD**
AHRI Reference Number: **208141951**

Cooling Mode Performance

Rated Cooling	9000 BTU/hr
Ambient Range	5°F ~ 122°F
SEER Rating	21.0 BTU/W·h
EER Rating	13.5 BTU/W·h

* 100% Capacity @ Indoor DB 80°F/WB 66°F / Outdoor DB 95°F/WB 75°F / m.w. 25' lineset

Heating Mode Performance

Rated Heating	10000 BTU/hr
Ambient Range	-13°F ~ 86°F
HSPF IV (V)	11.5 (9.2) BTU/W·h
COP	3.76 W/W

* High Heat (47°F) = 10000 BTU / Low Heat (17°F) = 6300 BTU / COP(5°F) = 1.75

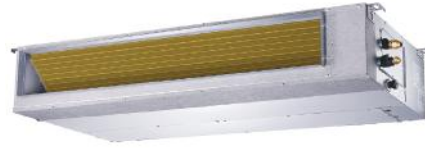

Slim Concealed Ducted Indoor Unit



Outdoor Condensing Unit



Installation Kit (Pipe+Cable)



Wired Controller + Remote

Electrical Information

Rated Input (W)	Cooling	Heating
	667	780
Rated Current (A)	3.05	3.57
Breaker Needed	15A (double-pole)	
Power Supply	208~230V, 1Ph, 60Hz	

Piping and Refrigerant

Liquid Line (OD)	1/4"
Suction Line (OD)	3/8"
Refrigerant Precharge	R410a (10 - 25 ft.)
Max Length/Height Diff.	82 Ft. / 33 Ft.

This combination is Energy-Star® certified.



Interior Unit (Air Handler) Specifications

Airflow Rate (CFM)	353 (Hi) / 282 (Med) / 176 (Lo)
Sound Level (dBA)	33.5 (Hi) / 28.5 (Med) / 27.0 (Lo)
ESP (Range)	0.0~0.16 in. wg. (0~40 Pa)
Dimensions (WDH)	27"-1/2 x 20" x 7"-7/8
Weight (Lbs)	39.0

Exterior Unit (Condenser) Specifications

Airflow Rate (CFM)	1,294
Sound Level (dBA)	54.5
Metering Device	Electronic Expansion Valve (EXV)
Compressor	Rotary
Dimensions (WDH)	30"-1/8 x 11"-7/8 x 21"-7/8"
Weight (Lbs)	63.7

RB009GMFILDFHD Air Handler Dimensional Data



Air Filter (optional) Air Inlet from Rear Side

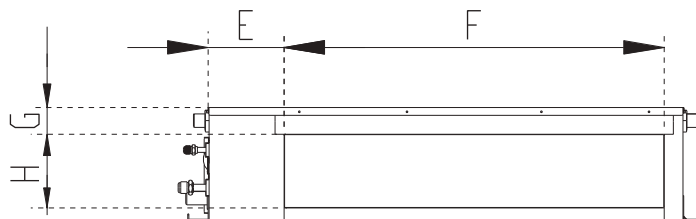
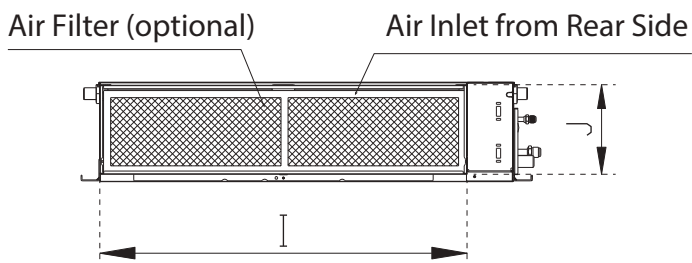

4-Corner Hanger

Electronic Control Box

Ø 1" Drain Pipe

Gas Side

Liquid Side

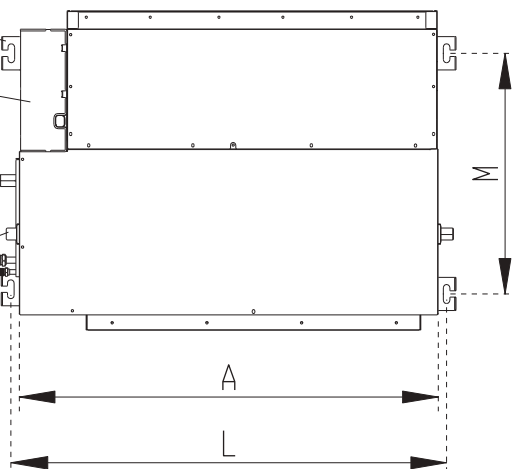

Test Mouth and Test Cover

Ø 1" Drain Connecting Pipe (for pump)

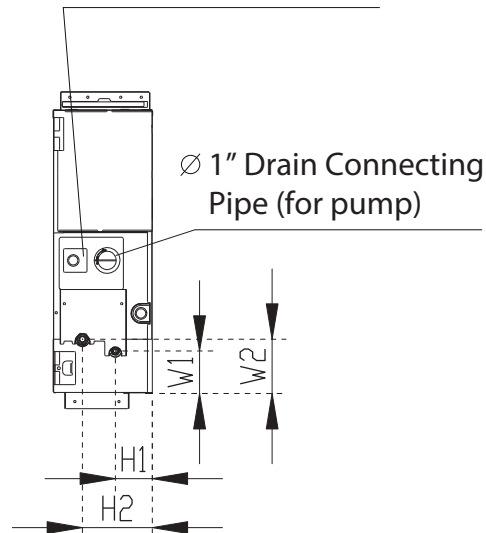

Air Filter (optional)

Air Inlet from Bottom Side

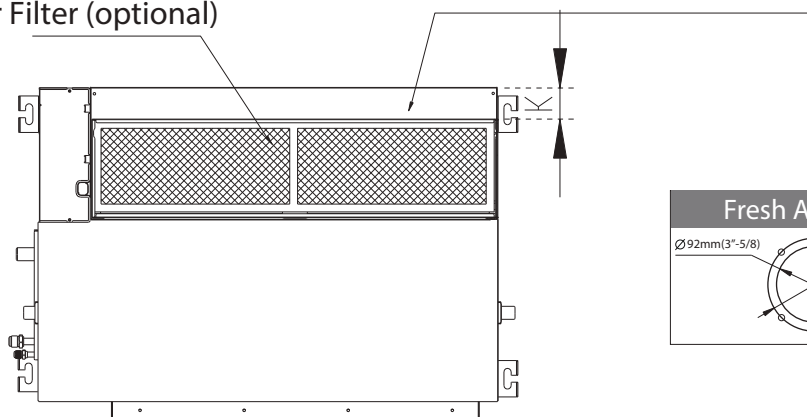

Fresh Air Intake

Ø92mm(3"-5/8) Ø113mm(4"-7/16)

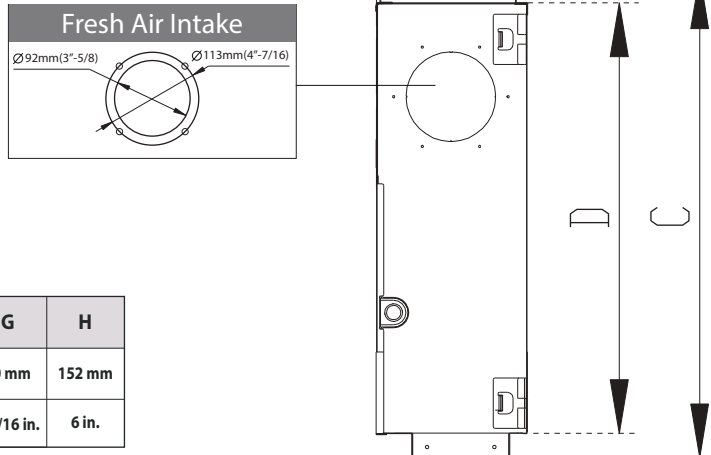

A	B	C	D	E	F	G	H
700 mm	200 mm	506 mm	450 mm	137 mm	537 mm	30 mm	152 mm
27-9/16 in.	7-7/8 in.	19-15/16 in.	17-3/4 in.	5-3/8 in.	21-1/8 in.	1-3/16 in.	6 in.

I	J	K	L	M	H1	H2	W1	W2
599 mm	186 mm	50 mm	741 mm	360 mm	84 mm	140 mm	84 mm	84 mm
23-9/16 in.	7-5/16 in.	2 in.	29-3/16 in.	14-3/16 in.	3-5/16 in.	5-1/2 in.	3-5/16 in.	3-5/16 in.

All dimensions are in Inches (mm)

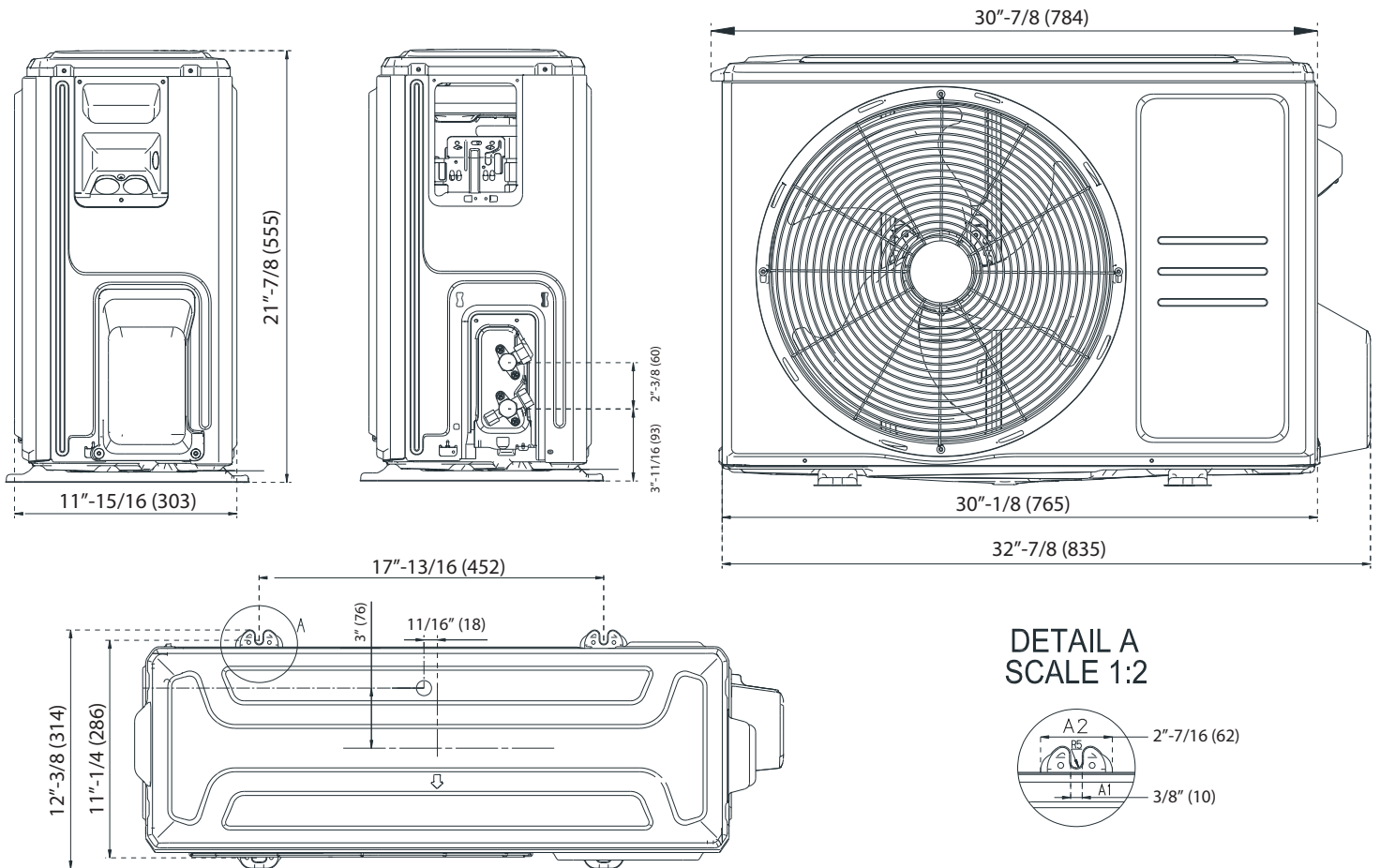

Warranty Information and Length



Complete warranty details are available with the vendor or online at <https://www.pdhvac.com/support/warranty/>. This high quality system is eligible for up to **5** years limited warranty on the compressor, and **5** years on other internal parts. To qualify for this warranty, the system must be installed within 90 days and registered properly. All other installations that are unregistered qualify for only **1** year parts/compressor warranty.

Outstanding Features

- Easy Clean Filter
- Flexible Air Intake
- High Static Pressure
- Eccentric Fan Design
- Slim Cabinet Footprint
- Built-In Condensate Drain Pump
- Horizontal or Vertical Installation
- Optional Programmable Controller

Available Accessories

Part Number	Description
IKT-LCVR4P-KIT	Decorative PVC Line Cover Kit
TST-LCACWIFIKP	Smart-WiFi Wired Wall Thermostat Kit
BRK-FRM-C-2P	Folding Mounting Bracket w/ Leveler
IKT-UVL32UL-AG	UVC Bacterial Disinfection Kit
@ICM517	Ultimate Surge and Power Protection