





SUBMITTAL DATA SHEET

Console Heat Pump System		ACIQ-12FM-HH-MB
Location: _____ Engineer: _____ Submitted to: _____ Submitted by: _____ Reference: _____	Approval: _____ Date: _____ Construction: _____ Unit #: _____ Drawing #: _____	

Set Code	22022610000400
Indoor unit code	22022611000207
Outdoor unit code	22022016016220
Set Model	
Indoor unit model	ACIQ-12FM-HH-MB
Outdoor unit model	
Certified	  



SYSTEM PERFORMANCE DATA			
Power supply			
Normal Operational Voltage	(V, Ph, Hz)	208/230V, 1Ph,	60Hz
Voltage Range	(V)		187-253
Electrical			
Minimum circuit ampacity(Outdoor)	(A)		15.0
Max.fuse(Outdoor)	(A)		15.0
Connection wiring			0
Cooling			
Capacity	(Btu/h)	12000(7600-14400)	
Power Input	(W)	902(170-1230)	
Current	(A)	4.13(1.42-5.51)	
SEER2	(Btu/W)		24.2
EER2	(Btu/W)		13.3
Heating			
Capacity	(Btu/h)	12000(5000-15700)	
Power Input	(W)	857(342-1450)	
Current	(A)	4.12(1.81-6.64)	
HSPF2.4	(Btu/W)		10.7
HSPF2-5	(Btu/W)		8.7
COP	W/W		4.10
Heat at 17F(H32)	(Btu/h)		10200
Heat at 5F(H42)	(Btu/h)		11900
COP at 5F(H42)	W/W		1.99

INDOOR UNIT DATA			
Indoor fan motor			
Model		ZKFP-13-8-136+ZKFP-13-8-104	
Qty			1+1
Input	(W)		/
Output	(W)		13.0
RLA	(A)		0.50
Speed(Hi/Mi/Lo)	(r/min)		992/884/776
Air flow & Noise level			
Indoor air flow (Hi/Med/Lo) (No duct)	(CFM)	441.18/376.47/323.53/264.71	
Indoor noise level (Hi/Med/Lo)	[dB(A)]		42/39/25
Dehumidification	(L/H)		1.4
Indoor unit			
Dimension (WxDxH)	(inch)	31.26x7.87x24.45	
	(mm)	794x200x621	
Packing(WxDxH)	(inch)	34.06x11.02x28.31	
	(mm)	865x280x719	
Net/Gross weight	(lbs.)		32.85/41.45
	(kg)		14.9/18.8

REFRIGERANT PIPE DATA			
Throttle type	Indoor unit		N/A
	Outdoor unit		EXV
Design pressure	(PSIG)		550/340
Refrigerant Type			R410A
Refrigerant charge	oz		41.62
Refrigerant precharge	(ft)		0.0
	(m)		0.0
Additional charge for each ft	(oz/ft)		0.16
Additional charge for each m	(g/m)		15.0
Liquid side/ Gas side(indoor)	(inch)	1/4"/1/2"	
	(mm)	6.35/12.7	
Liquid side/ Gas side(outdoor)	(inch)	1/4"/1/2"	
	(mm)	6.35/12.7	
Max. pipe length	(ft)		82.0
	(m)		25.0
Max. difference in level	(ft)		32.8
	(m)		10.0
Connection method			Flared
Indoor(cooling)	(Deg. °F)		60~90
	(Deg. °C)		16~32
Indoor(heating)	(Deg. °F)		32~86
	(Deg. °C)		0~30
Outdoor(cooling)	(Deg. °F)		-22~122
	(Deg. °C)		-30~50
Outdoor(heating)	(Deg. °F)		-22~75
	(Deg. °C)		-30~24

OUTDOOR UNIT DATA			
Compressor			
Type			ROTARY
Model			KTN110D42UFZ
Brand			GMCC
Capacity	(Btu/h)		11823
Input	(W)		885
Rated current (RLA)	(A)		8.8
Refrigerant oil/oil charge	(ml)		VG74/350
Outdoor fan motor			
Model		ZKFN-34-10-1	
Qty			1
Input	(W)		/
Output	(W)		34.00
RLA	(A)		0.36
Speed	(r/min)		850/680/450
Air flow & Noise level			
Outdoor air flow (Max.)	(CFM)		1323.5
Outdoor noise level	[dB(A)]		56.0
Outdoor unit			
Dimension (WxDxH)	(inch)	31.69x12.99x21.81	
	(mm)	805x330x554	
Packing (WxDxH)	(inch)	36.02x14.57x24.21	
	(mm)	915x370x615	
Net/ Gross weight	(lbs.)		73.63/79.37
	(kg)		33.4/36

Indoor unit dimension

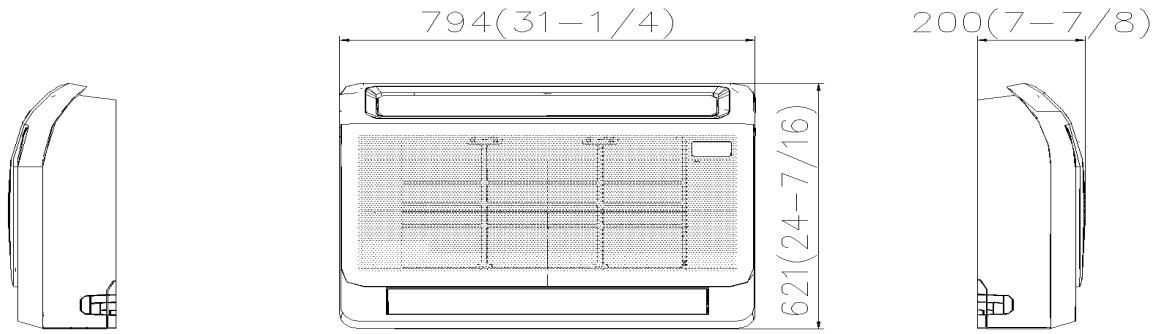

Outdoor unit dimension

