

BLASTER BOARDS®

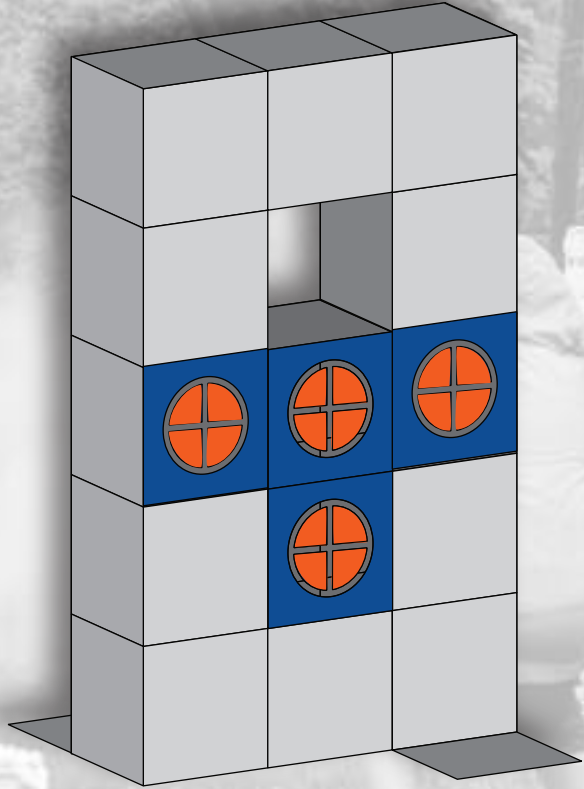

BUILD DIRECTIONS

BUILD SIZE: [2] PACK/S

IDEAL FOR: [] OPTIMAL COVERAGE
[X] OPTIMAL STRENGTH

CAUTION: DO NOT CLIMB OR ADD WEIGHT ONTO
BUILT STRUCTURES HIGHER THAN GROUND LEVEL.

BLASTER-BOARDS.COM

Straight Connection

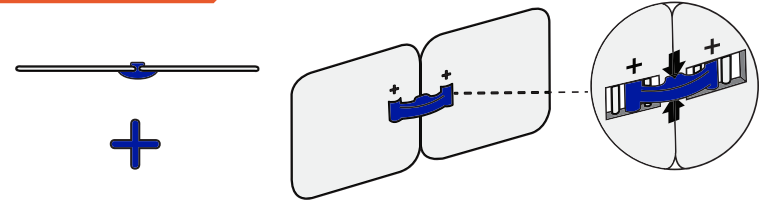

30° Connection

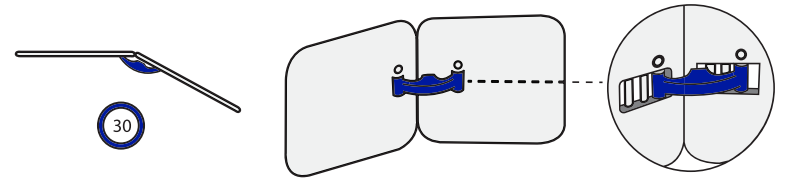

45° Connection

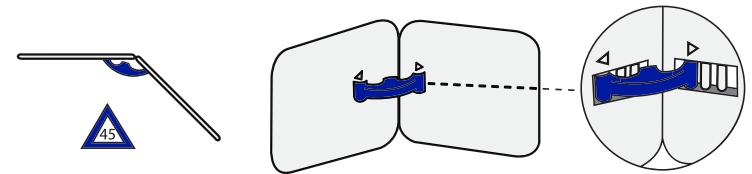

90° Connection

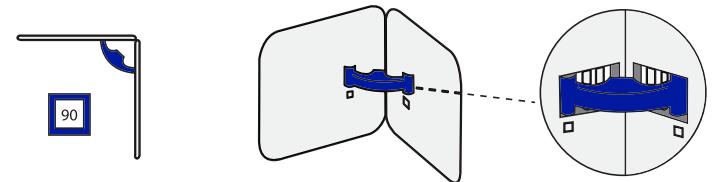

No Connector

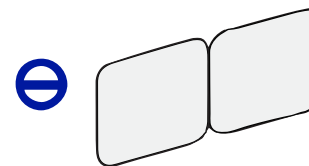

Not Attached

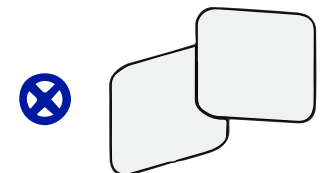

1

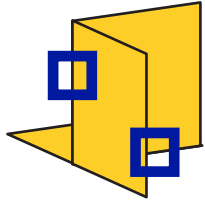

2

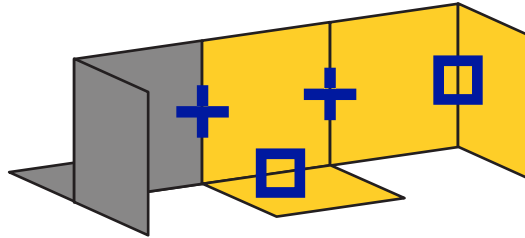

3

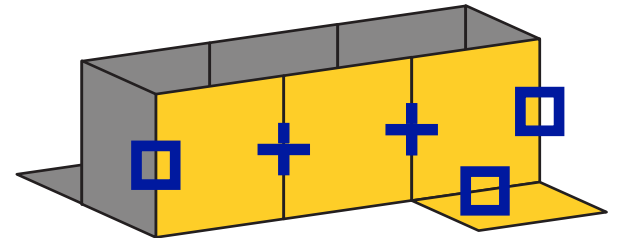

4

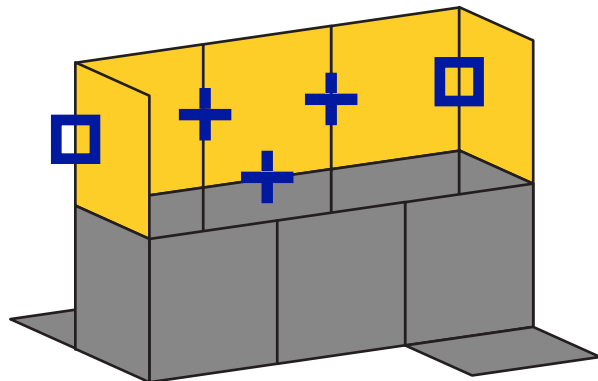

5

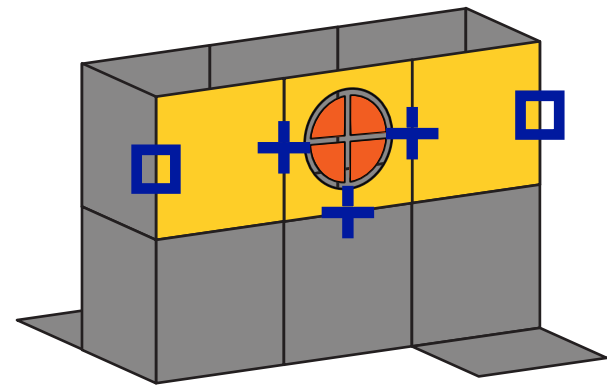

6

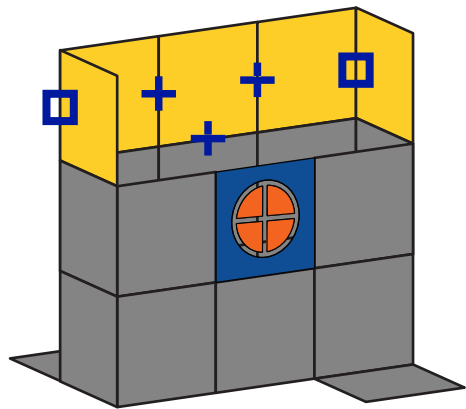

7

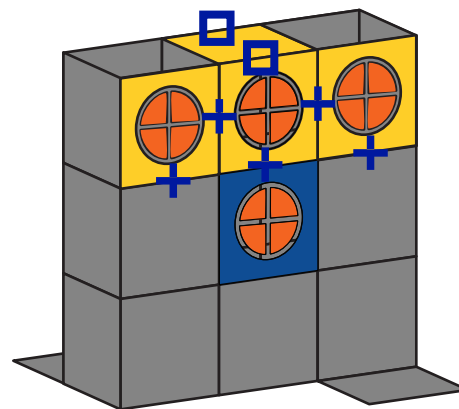

8

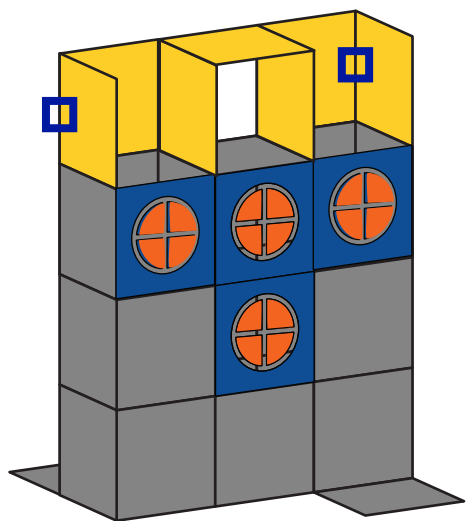

9

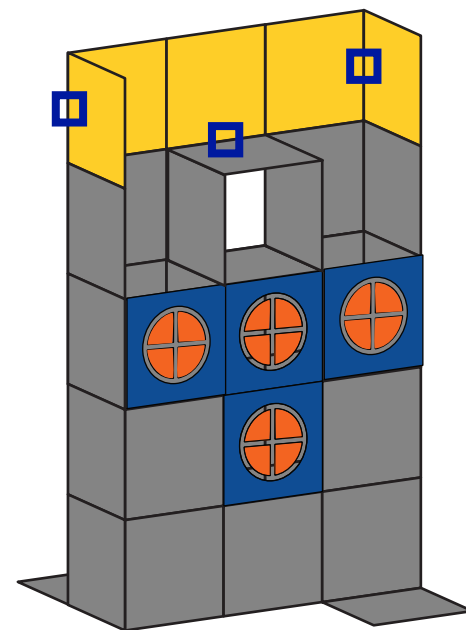

10

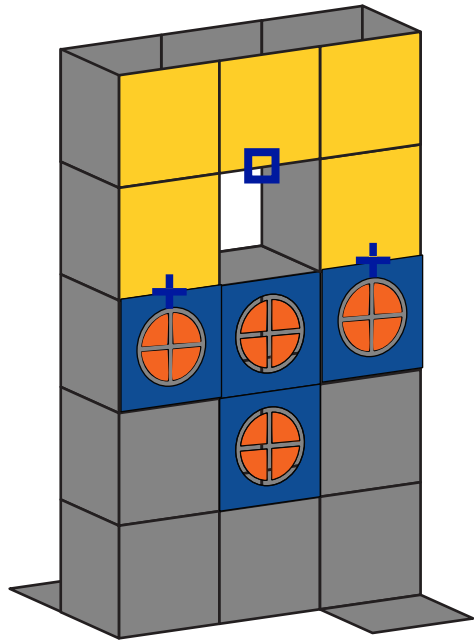

11

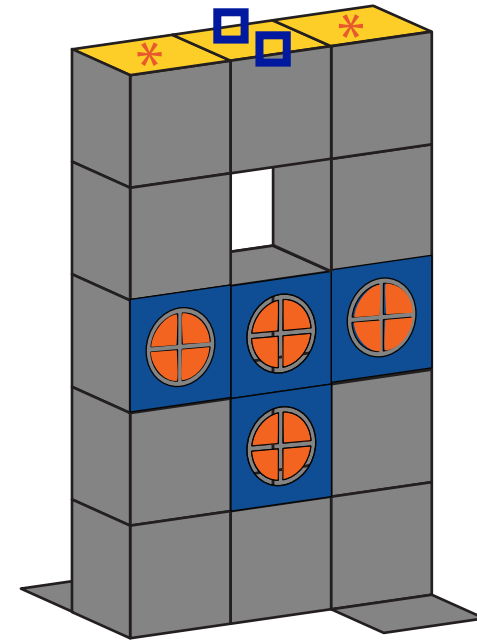

WANT EVEN MORE STABILITY? PUT THE TWO BOARDS MARKED WITH * DOWN ON THE BOTTOM AS TWO EXTRA FEET.



We love showing off your creativity!
Tag your photos with: **#BlasterBoards**