

ALMAX Dellaria-100 Industrial Dehumidifier with Tank

EN



FDE-100 Technical Manual

ENGLISH MANUAL

USERS INFORMATION

"Implementation of directive 2012/19 / EU on waste electrical and electronic equipment (WEEE)".

The barred waste bin symbol indicates that the product must be collected separately from other waste at the end of its life.

Separate collection of this equipment at the end of its life is organized and managed by the manufacturer.

The user who wishes to dispose of the equipment should contact the manufacturer for information on the system adopted by the latter to allow the separate collection at the end of life.

Alternatively, for all equipment to be disposed of with dimensions of less than 25 cm is the possibility of free delivery to electronics retailers, with sales area of at least 400 m², with no obligation to purchase another similar appliance.

Appropriate separate collection for the subsequent forwarding of the decommissioned product to recycling, treatment and environmentally compatible disposal helps prevent negative impact on the environment and on health and promotes the reuse and / or recycling of the materials making up.



EN

1 INTRODUCTION

1.1 General instructions



The original manual was written in Italian.

The manual is intended for the end user only for operations that can be performed with closed panels. **Operations requiring the opening of doors or panels with tools must be performed only by expert personnel.** Each unit must be connected to the power supply via a cable with a power plug in the unit with the unit

For maintenance operations, the power plug must always be disconnected allowing the operator to intervene in safe conditions.

To identify the unit (model and serial number), in the event of a request for assistance or spare parts, read the identification plate located outside the unit.

EN

1.2 Reference standards

The appliance described in this manual has been designed in accordance with the European and international reference technical standards.

The appliance meets the essential requirements of the following European Directives:

- Electrical safety for low voltage applications 2014/35/UE,
- Electromagnetic compatibility 2014/30/UE,

1.3 General safety rules

The purpose of the manual and all the documentation supplied with the system is to enable both the installer and the operator to correctly install, start up and maintain the appliance, without causing damage. to the staff and to the unit.

Every unit is subject to a risk assessment carried out in compliance with the current legislation that defines the necessary actions and implements the protective measures necessary to achieve the risk reduction objectives.

It is advisable to perform all the activities related to the operation and maintenance of the unit:

- Only by appropriately trained persons who must adopt safe working practices and use PPE appropriate to the specific task performed, based on their specific qualification.
- Only by appropriately trained persons who have completely read and understood the manuals, technical documents and security documents.
- Access to the appliance must be denied to anyone who is not adequately trained and competent.

Manuals, wiring diagrams and documentation attached to the unit must be read and kept for the entire life of the appliance.



Warning: This appliance is designed for use in an indoor environment.



Warning: The appliance must be installed in compliance with local wiring regulations.



Warning: The appliance must be installed respecting the dimensions and the necessary spaces including the minimum spaces allowed by the adjacent structures.



Warning: This appliance must always be connected using plugs with a grounding cable, as required for all electrical applications; Productor declines all responsibility for any danger or damage caused if this rule is not respected.



Warning: This appliance has been designed and built in accordance with the strictest safety rules. Consequently, sharp instruments (screwdrivers, needles or similar) must not be inserted into the grids or any other openings in the panels, especially when the unit is open to remove the filter.



Warning: All maintenance and cleaning operations on the unit must be done with the power supply disconnected. Never remove the front grille or open any part of the unit without first removing the plug from the socket.



Warning: The unit must not be cleaned using water. Use a damp cloth to clean the unit. Never spray water on the unit or its electrical components. When the appliance is connected to the socket, it must be placed in a vertical position and any sudden movement must be avoided because it could cause water to come into contact with the electrical parts; **it is recommended to move the unit only after emptying the condensate tank. In any case it is ALWAYS NECESSARY to remove the plug from the socket before moving the unit; if water has to be poured on the unit, the device must be switched off and can be switched on after 8 hours.**



ATTENTION: The appliance contains R1234YF refrigerant: this gas is highly flammable. The amount of charge is 0,385 kg.

EN

Pay attention: the refrigerant is odorless.

Do not use means to accelerate the defrosting process or to clean, other than those recommended by the manufacturer.

The appliance shall be stored in a room without continuously operating ignition sources (for example : open flames, an operating gas appliance or an operating electric heater.

Do not pierce or burn..



Warning: The unit was not designed to be used by people (including children) whose physical, sensory or mental capabilities are reduced. Even people without experience or knowledge of the appliance cannot use it. The people described above can use this unit only under the responsibility of an expert who checks their work and provides the appropriate instructions. Children must be supervised to ensure that they do not play with the appliance.

1.4 Personal protective equipment

For the operations of use and maintenance of the units, use the following means of personal protection:



Clothing: those who carry out maintenance or work with the unit must wear safety shoes with non-slip soles in rooms with slippery floors



Gloves: During cleaning and maintenance operations, the use of appropriate gloves is required. In the case of refrigerant gas refilling, the use of appropriate gloves is mandatory to avoid the risk of freezing.



Mask and glasses: during cleaning and maintenance operations, respiratory protection masks and eye protection goggles must be used.

1.5 Safety signs

The unit reports the following safety signs, which must be respected:



Read technical manual



Read user's manual



Read operator's manual



Danger of electric shock



Flammable material hazard



Warning:

It is strictly forbidden to remove the safety signs present in the unit.

2 General description of the unit

The portable dehumidifiers are devices suitable for humidity control.
They have a washable dust filter and a condensation collection tray.

The units are controlled by an electronic microprocessor board that manages all the functions of the device: general operation, automatic defrosting system, alarms and humidity regulation.



EN



2.1 Refrigerant circuit



The refrigerant gas used in these units is R1234yf. The refrigerant circuit is made in compliance with current standards

Flammable material hazard

This unit is hermetically sealed and contains R1234yf fluorinated gas.
GWP (R1234yf) = 4

3 Preliminary operations

3.1 Packaging removal

Remove the packaging taking care not to damage the unit. Dispose of the packaging products (wood, plastic, cardboard) and send them to be specialized collection or recycling centres (follow local regulations in force).

3.2 Inspection

All units are assembled and wired at the factory. Upon receipt of the unit, it must be inspected immediately, carefully checking that it has not been damaged during transport or that there are no missing parts; any complaints must be notified to the carrier and the factory or his representative within 8 days.

EN



Before use, check in particular that there are no dents on the external metal panels, including those of the tank compartment. Also check that the cable, plug and relative insulation are intact. Otherwise, it is FORBIDDEN to connect and start the unit, which must be sent to an authorized service centre.

3.3 Operating limits

The following diagram represents the operating range of standard units.



Warning: It is strongly recommended to operate the unit within the limits shown below. Overcoming these limits does not guarantee either the normal operation or the reliability of the group or even the integrity (for special applications, please contact our office).

Operation table

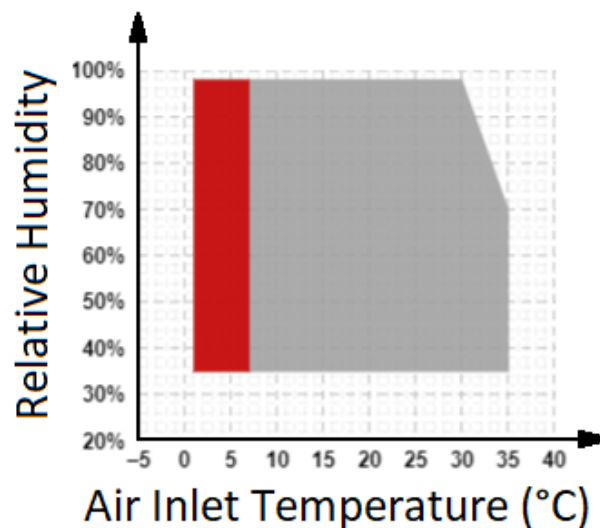

Note: On the left is indicated the extension of the operating limits if operating with versions equipped with a hot gas defrost system.

3.4 Positioning

Place the device in order to guarantee an adequate air flow.



Warning: Make sure the device is positioned so that it does not come into contact with water.

3.5 Service area

The hot air expelled by the fans must not find obstacles.

Avoid phenomena of recirculation of the hot air between suction and delivery, otherwise the performance of the unit will deteriorate or even the normal operation will be interrupted.



Warning: The device must not be placed in confined spaces, which do not allow adequate diffusion in the room of the air coming from the front grill.



Warning: Do not place or hang objects on the front panel, it may cause damage to the unit

3.6 Overview



Warning: Attention: Before any maintenance on the electrical section, make sure that the power supply is disconnected.



Warning:

Check that the power supply voltage corresponds to the unit nominal data (voltage, frequency) shown on the plate on the unit. The power connection is via plug with cable.



Attention:

Grounding is mandatory.

4 Start up

4.1 Preliminary checks



Warning: Check that power cable is properly connected.



Warning: before starting up, check that all the cover panels are in the correct position and are locked with fixing screws. Attention: before starting up, check that all the cover panels are in the correct position and are locked with fixing screws.



Warning: For temporary shutdown (night, weekend, etc.) never interrupt the power supply and follow the procedures illustrated in the paragraph on device shutdown

EN

4.2 Control panel

The units are equipped with a led signalling panel that indicates the operating status of the unit. Below is a brief description of their meaning.

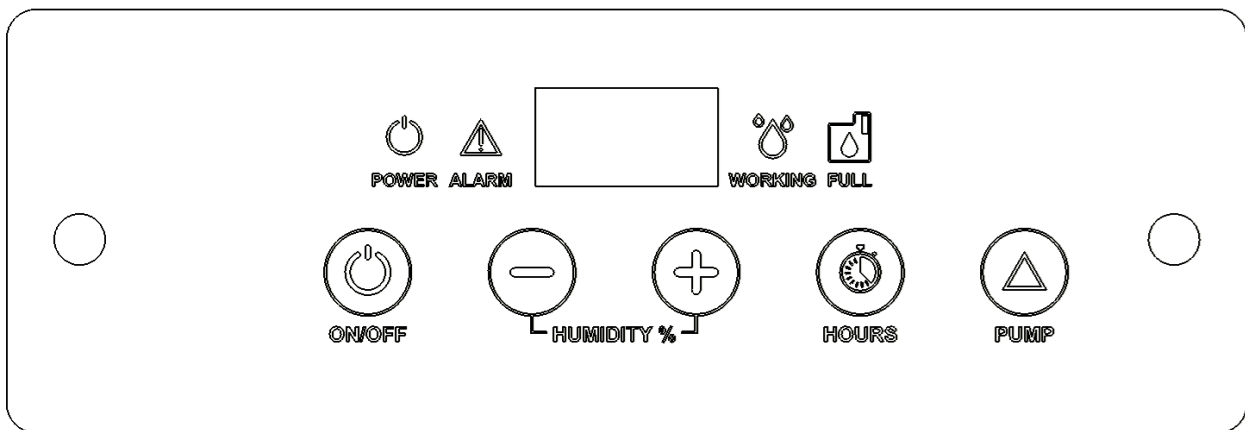

POWER

POWER LED: This LED is lit if the appliance is enabled to work (via ON-OFF key). If the machine is connected to the power supply, the display shows the relative humidity value.



ALARM

ALARM LED: This LED, if lit, indicates the presence of an alarm. The display will show the error message.



WORKING

WORKING LED: This LED is lit while the appliance is working. It flashes during compressor pauses and defrosting.



FULL

FULL LED: This LED, if on, indicates that the tank is full or the pump is in alarm (if applicable).



ON/OFF

ON-OFF: Press the ON / OFF button to switch the appliance on and off.
Note: when the appliance is turned off and immediately on, the compressor does not start immediately. After 210 seconds, the appliance restarts.



SET HUMIDITY %: Press the keys to set the desired set point value.







HOUR COUNTER: Press the HOURS button to view the operating hours.



PUMP: Press the PUMP button to force emptying.

If there is no water in the pump, do not force the emptying or the pump will be damaged. Normally the pump is automatically started/stopped by the pump's internal sensor.

4.3 Alarm list

PROBLEM	PROBABLE CAUSE and CORRECTIVE ACTIONS
 FULL + "FuLL"	Full tank or pump in alarm. Full tank: the alarm is automatically reset by emptying the tank. Pump in alarm: check the electrical connection of the pump and that no restriction is present on the delivery pipe. Otherwise, please contact the service centre for the replacement.
 ALARM + "Lo t"	It occurs when the ambient temperature is too low. To restore, put the unit in an environment above 10 ° C, if it is not reset, set it to OFF with the POWER button and disconnect the power supply.
 ALARM + "Prob"	Malfunction of the humidity probe. The unit continues to operate in continuous mode without humidity control. Please contact the service centre for the replacement
 ALARM + "Pro3"	Temperature probe malfunction. In any case, the device continues to operate. Please contact the service centre for the replacement.
 ALARM + "dEFr"	Defrost thermostat malfunction Dehumidifier goes to stand-by. Please contact the service centre for the replacement.

4.4 Draining pump connection

It is possible to connect a tube to a hose holder in the tank, whose diameter is 16 mm

4.5 Condensate pump connection (optional)

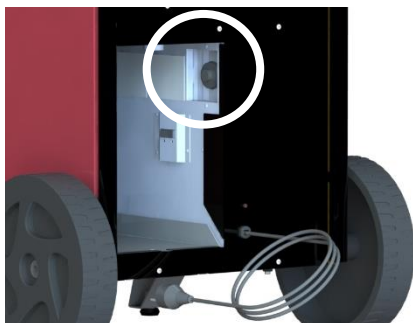

Disconnect the unit from the power supply before connecting the condensate pump.
 Remove the condensate collection tank and position the pump inside the tank compartment.
 For the electrical connection, follow the instructions attached to the pump accessory.
 The pump is connected via a 6 PIN connector on the prepared unit.

5 Maintenance

5.1 Checks to be carried out by the user

The only maintenance to be carried out by the user is the cleaning of the air filter, which must be carried out at least once a month.

The frequency of cleaning can be intensified due to the dustiness of the working environment of the appliance.

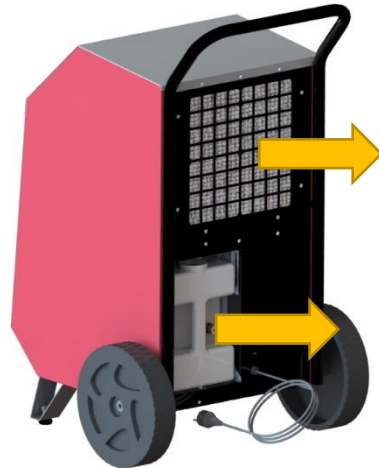

EN



ATTENTION: TO PERFORM THE CLEANING OF THE FILTER, THIS MUST ALWAYS BE REMOVED FROM THE UNIT.

IT IS FORBIDDEN TO PERFORM CLEANING WITH THE FILTER MOUNTED ON THE UNIT.

5.2 Spare parts

The only maintenance to be carried out by the user is the cleaning of the air filter, which must be carried out at least once a month.

The frequency of cleaning can be intensified due to the dustiness of the working environment

Should it be necessary to replace one or more parts during maintenance by specialized operators, this must be done using only original spare parts

5.3 Decommissioning

The device has been designed and built to guarantee continuous operation. The duration of some main components, such as the fan and the compressor, depends on the maintenance to which they have been subjected.



Warning: The unit contains substances and components that are dangerous for the environment (electronic components, refrigerant gas and oils). At the end of the useful life, in case of dismantling of the unit, the operation must be performed by specialized refrigeration personnel. The unit must be assigned to special specialized centres for the collection and disposal of equipment containing dangerous substances. The refrigerant and the lubricating oil contained in the circuit must be recovered, in accordance with the regulations in force in your country.

6 Information on maintenance by specialist operators only.

6.1 Checks to the area

Prior to beginning work on systems containing flammable refrigerants, safety checks are necessary to ensure that the risk of ignition is minimized. For repair to the refrigerating system, the following precautions shall be complied with prior to conducting work on the system.

6.1.1 Work procedure

Work shall be undertaken under a controlled procedure so as to minimize the risk of a flammable gas or vapour being present while the work is being performed.

6.1.2 General work area

All maintenance staff and others working in the local area shall be instructed on the nature of work being carried out. Work in confined spaces shall be avoided. The area around the workspace shall be sectioned off. Ensure that the conditions within the area have been made safe by control of flammable material.

6.1.3 Checking for presence of refrigerant

The area must be checked with a special explosimeter before and during work, so that the technician can reliably verify the possible presence of potentially flammable atmospheres. It must be ensured that the leak detection apparatus is suitable for use with flammable refrigerant fluids, namely:

- 1) Suitable for detecting the type of gas used in the unit.
(R1234yf: Tetrafluoropropene).
- 2) Suitable for use in Atex hazardous areas (at least zone 2).

6.1.4 Presence of fire extinguisher

It is forbidden to perform hot working on parts of the unit before this has not been completely emptied of the flammable refrigerant fluid, and that it has been subjected to an accurate process of reclamation by inert gas (flushing) in all parts of the circuit. In this regard, see the specific section relating to the flushing operation. Only at the end of this operation can it be considered that the refrigerant circuit and its parts no longer contain significant quantities of flammable fluid. In any case, it is always necessary to have an appropriate flame extinguishing apparatus available.

6.1.5 No ignition sources

Personnel who perform maintenance on the unit which requires direct intervention and / or exposure of pipes that contain or have contained a flammable refrigerant fluid must not use tools or devices that represent a source of ignition.

All possible ignition sources must be kept away from the place of maintenance, repair, removal and disposal, operations during which the flammable refrigerant fluid could be accidentally released into the surrounding space

6.1.6 Ventilated area

During maintenance activities, continuous ventilation must be present, so that an accidental dispersion of flammable refrigerant fluid can be diluted in the atmosphere. Please note that in any case the dispersion in free air must be considered an extraordinary situation linked to events of an involuntary or accidental nature

6.1.7 Checks to the refrigeration equipment

The replacement of the electrical parts of the unit must only be carried out by qualified personnel (see EN 600079-14). The replacement must be carried out with original and homologous spare parts. Do not proceed with any replacement if the appropriate spare part is not available. If in doubt, contact the service centre.

The following checks must be carried out on appliances that use flammable refrigerant fluids:

- a. that the ventilation devices and outlets function properly and are not obstructed;
- b. if an indirect refrigeration circuit is used, the presence of refrigerant fluid in the secondary circuit must be checked;
- c. the marking on the appliance must remain visible and legible. Markings and graphic signs that are illegible must be correct;

6.1.8 Checks to electrical devices

Initial safety checks and component examination procedures must be included in the repair and maintenance of electrical components. IT IS FORBIDDEN to proceed with the power supply of the unit until the fault has been resolved satisfactorily

Initial security checks must include:

- that the capacitors are discharged: this operation must be carried out safely to avoid the possibility of creating sparks;
- that there are no live electrical components and that the cables are not exposed while charging, recovering or bleeding the system;
- that there is continuity in the earth connection.

EN

6.2 Repairs to sealed components

- 1) During repairs to sealed components, all power supplies must be disconnected from the appliance being worked on before removing the sealed covers.
- 2) Particular attention must be paid to the following to ensure that, when working on the electrical components, the casing does not alter so as to compromise the level of protection. Attention should also be paid to damage to the cables, previous modifications of the circuits that are not consistent with the technical documentation supplied with the unit., Damage to the gaskets, incorrect fixing of the cable glands.

Make sure that the equipment is securely mounted.

Make sure that the gaskets and sealing materials have not deteriorated to the point that they are no longer suitable for the purpose of preventing development in flammable atmospheres. Spare parts must be in accordance with the manufacturer's prescriptions.

NOTE The use of silicone sealant can impair the effectiveness of some types of spill detection instruments.

6.3 Cabling

Check that the cables are not subject to wear, corrosion, excessive pressure, vibrations, sharp edges or any other situation that could compromise their continuity and / or insulation. The check shall also take into account the effects of aging or continual vibration from sources such as compressors or fans.

6.4 Detection of flammable refrigerants

Under no circumstances shall potential sources of ignition be used in the searching for or detection of refrigerant leaks. A halide torch (or any other detector using a naked flame) shall not be used.

6.5 Leak detection methods

The following methods of detecting spills are believed to be acceptable for systems that contain flammable refrigerant fluids.

Electronic leak detectors should be used to detect the presence of flammable refrigerant fluids, but their sensitivity may not be adequate or may need to be re-calibrated. (The detection equipment must be calibrated in an area without refrigerant fluid). Make sure that the detector is suitable for operating in an ATEX atmosphere (at least zone 2), that it is suitable for the refrigerant fluid used. The detection equipment must be set at a percentage of the LFL of the refrigerant fluid and must be calibrated for the refrigerant fluid used, and the appropriate percentage of gas (maximum 25%) must be confirmed.

| Fluid leak detectors are suitable for use with most refrigerant fluids but the use of detergents that contain bleach must be avoided as they can react with the refrigerant fluid and corrode the copper piping network.

If a leak of refrigerant fluid is found that requires repair with hot work (e.g. brazing) it is necessary to proceed with an accurate flushing procedure with inert gas, according to the indications given in the following point.

6.6 Removal and evaluation (flushing)

When performing maintenance operations on parts of the refrigerant circuit that do not provide for the use of ignition sources and / or hot work, conventional procedures can be followed. If, on the other hand, interventions involving the use of ignition sources and / or hot work must be carried out,

or if it is not possible to establish a priori the nature and extent of the maintenance operations to be performed, it is necessary to proceed with the complete removal of the refrigerant gas and reclamation, through a procedure called "flushing".

- remove the refrigerant fluid by means of a vacuum pump, transferring it to suitable containers (cylinders);
- Add the inert gas (OFN: Oxygen Free Nitrogen) using the vacuum condition present, taking care to check that all parts and components of the circuit are in a condition to receive the gas; do not put the circuit under pressure with the inert gas, but return to atmospheric pressure conditions;
- Open the circuit in one or more points so that the inert gas can be exhaled externally;
- Carry out the inert gas supply with the circuit open, in order to remove any traces of refrigerant fluid still trapped inside.

The gas supply must be continued for a time that, depending on the flow of the aforementioned gas, allows an overall "washing" of the inside of the circuit for 5 equivalent volumes.

At the end of this operation, maintenance activities can be carried out.

ATTENTION: INERT GAS OFN IS A NON-BREATHABLE FLUID (DANGER OF ASPHYXIA); THE VENT IN THE ATMOSPHERE OF SUCH A FLUID MUST BE DONE AWAY FROM THE OPERATOR.

EN

6.7 Charging procedures

- Make sure that when using a refill equipment, contamination between different refrigerant fluids does not occur. | flexible hoses or pipes must be as short as possible to minimize the amount of refrigerant contained in them.

- The cylinders must be kept upright.

- Make sure that the refrigeration system is grounded before proceeding to recharge the system with the refrigerant fluid.

- Label the system when charging is complete, (if not already done).

- Particular care must be taken not to overload the refrigeration system.

Before recharging, the system must be subjected to the pressure test with OFN. The system must undergo a leak test at the end of charging but before putting it into operation. An additional leak test must be performed before leaving the site.

6.8 Decommissioning

Before carrying out this procedure, it is essential that the technician is totally familiar with the apparatus and all its details. It is good practice that all refrigerant fluids are safely stored. Before carrying out the work, oil and cooling fluid samples must be taken in case an analysis is required before using the cooling fluid again.

It is essential that electricity is available before starting work.

Before carrying out this procedure, it is essential that the technician is totally familiar with the apparatus and all its details. It is good practice that all refrigerant fluids are safely stored. Before carrying out the work, oil and cooling fluid samples must be taken in case an analysis is required before using the cooling fluid again.

It is essential that electricity is available before starting work.

- a) Become familiar with the apparatus and its operation
- b) Isolate the system from an electrical point of view.
- c) Before trying the procedure, make sure that
 - a mechanical manoeuvring device is available, if required, to handle the refrigerant fluid cylinders;
 - all personal protective equipment is available and used correctly;
 - that the recovery process is constantly under the control of a competent person;
 - the recovery apparatus and the cylinders comply with the relevant standards.
- d) Depressurize the cooling system, if possible.
- e) If the vacuum cannot be obtained, connect a manifold so that the refrigerant fluid can be removed from various parts of the system.

- f) Make sure that the cylinder is located on the scale before recovery takes place.
- g) Start the recovery unit and operate it according to the manufacturer's instructions.
- h) Do not overfill the cylinders (no more than 80% by volume of the refill liquid).
- i) Do not exceed, even temporarily, the maximum operating pressure of the cylinder.
- j) When the cylinders have been correctly filled and the process is finished, check that the cylinders and the equipment are removed promptly from the site and that all the isolation valves of the appliance are closed.
- k) Recovered refrigerant fluids must not be loaded into another refrigeration system unless they have been cleaned and checked.

6.9 Labelling

The appliances must bear a label stating that they have been taken out of service and emptied of the refrigerant fluid. The label must be dated and signed. Make sure that labels have been affixed to the appliance stating that the appliance contains a flammable refrigerant.

6.10 Recovery

When removing refrigerant fluids from a system, either for maintenance or for decommissioning, it is good practice that this is done safely.

When transferring the refrigerant fluid into the cylinders, check that only cylinders suitable for the recovery of refrigerant fluids are used. Make sure that the exact number of cylinders is available to contain the total refill of the system. All cylinders to be used are designated for the refrigerant fluid kept and labelled for that refrigerant fluid (i.e., cylinders for the storage of the refrigerant fluid). The cylinders must be complete with a pressure relief valve and associated shut-off valves, in good working order. The empty guard cylinders are withdrawn and, if possible, cooled before recovery occurs.

The recovery apparatus must be in good operating condition with a series of instructions relating to the apparatus being managed and must be suitable for the recovery of flammable refrigerating fluids. A set of calibrated weighing scales must also be available. The pipes must be equipped with connectors for disconnection that do not leak and are in good operating condition. Before using the recovery machine, check that it is in a satisfactory condition of use, that it has had proper maintenance and that any associated electrical components are sealed to prevent ignition in case of leakage of refrigerant fluid. Consult the manufacturer if in doubt.

The recovered refrigerant fluid must be returned to the supplier of the refrigerant fluid in the appropriate recovery cylinder, drawing up the relative Waste Transfer Note. Do not mix the refrigerant fluids in the recovery units and, in particular, not in the cylinders.

If the compressors or their oils need to be removed, make sure they have been emptied to an acceptable level to ensure that the flammable refrigerant fluid does not remain in the lubricant. The evacuation process must be carried out before the compressor returns to the suppliers. Only electric heating to the compressor body must be used to speed up this process. Draining the oil from a system must be done safely.

TECHNICAL AND PERFORMANCE DATA

Mod.	FDSDP62S
<i>Power supply</i>	230 V 1 ph 50 Hz
<i>Rated Aver. Power Consumpt. (at 27°C, 60%)</i>	750 W
<i>Max Power Consumption (at 35°C,70%)</i>	890 W
<i>Max. Absorbed Current (at 35°C, 70%) F.L.A</i>	4,4 A
<i>Locked Rotor Current L.R.A.</i>	24 A
<i>Air Flow</i>	550 m ³ /h
<i>Sound Pressure Level (at 3 mts in free field)</i>	50 db (A)
<i>Refrigerant</i>	R1234YF
<i>Standard Defrosting Control System</i>	<i>electronic</i>
<i>Hot gas defrosting control system</i>	<i>Thermost/electronic</i>
<i>Capacity of Condensed Water Tank</i>	14 L
<i>Cond. Water Draining Pipe Connection (male)</i>	3/4"
<i>Functioning Temp. Range (hot gas defrost. version)</i>	1-32 °C
<i>Functioning Relative Humidity Range (<30°C)</i>	35 - 98 %
<i>Rated Condensation Capacity (30°C-80%)</i>	52 l/d
<i>Rated Condensation Capacity (32°C-90%)</i>	62 l/d
<i>Weight with</i>	44 kg
<i>Dimensions LxDxH including handle & wheels</i>	55x56x95 cm

CONDENSED WATER AT DIFFERENT AMBIENT TEMPERATURE AND HUMIDITY CONDITIONS												
Mod.	10°C 60%	10°C 80%	15°C 60%	15°C 80%	20°C 60%	20°C 80%	25°C 60%	25°C 80%	27°C 65%	27°C 80%	30°C 80%	32°C 90%
62	10 l/24h	17l/24h	14l/24h	22l/24h	19l/24h	27l/24h	23l/24h	34l/24h	29l/24h	36 l/24h	52l/24h	62l/24h

ELECTRIC SCHEME

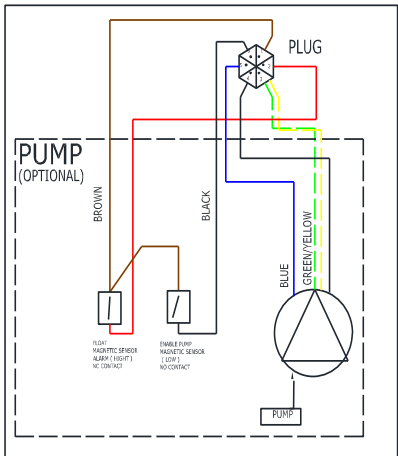
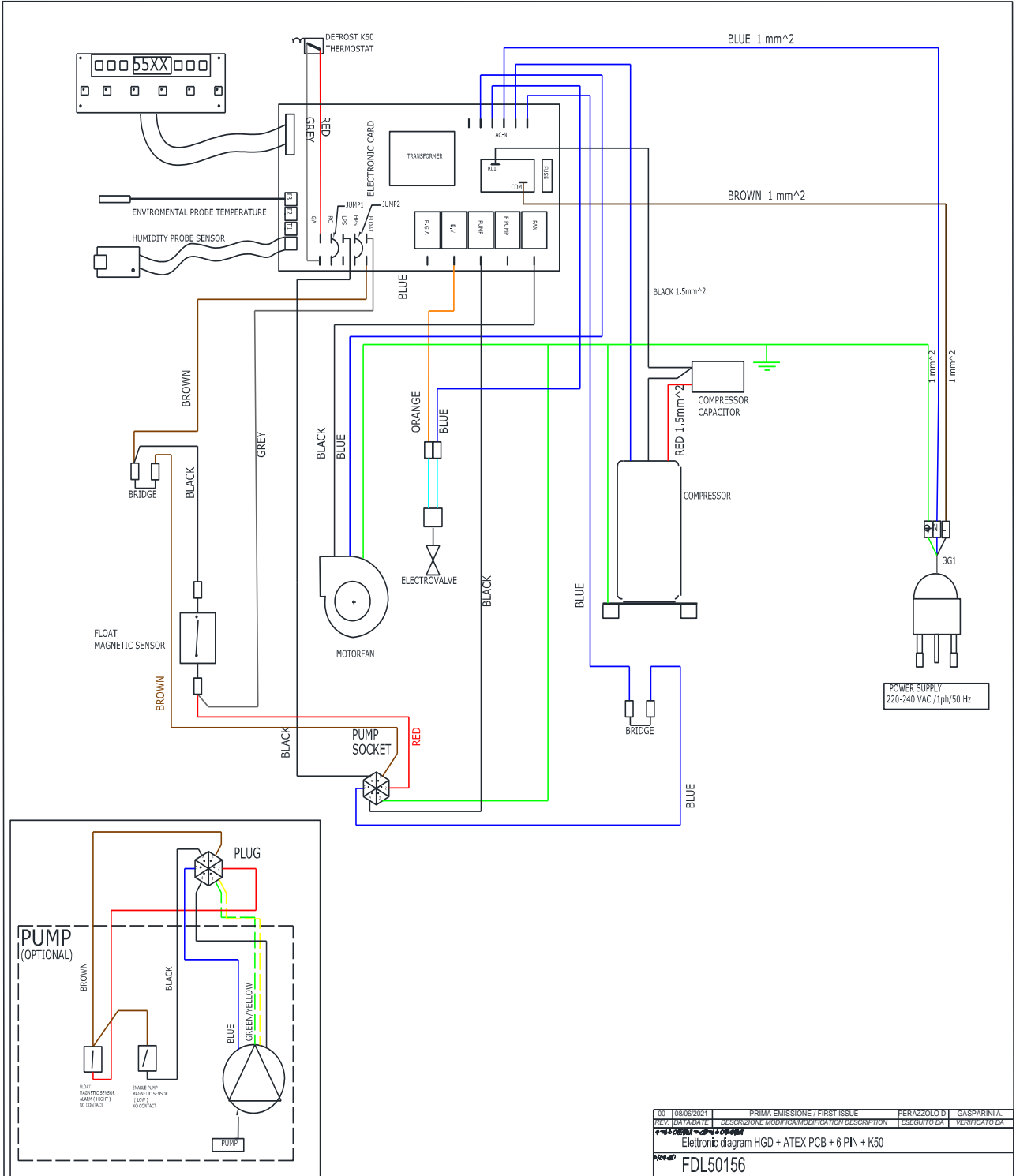

REV.	DATE/LATE	DESCRIZIONE / MODIFICA / MODIFICATION / DESCRIPTION	ESEGUITO DA / VERIFICATO DA
00	08/06/2021	PRIMA EMISSIONE / FIRST ISSUE	PERAZZOLO D / GASPARINI A
Elettronico diagram HGD + ATEX PCB + 6 PIN + K50 FDL50156			

ELECTRIC SCHEME WITH ENERGY METER

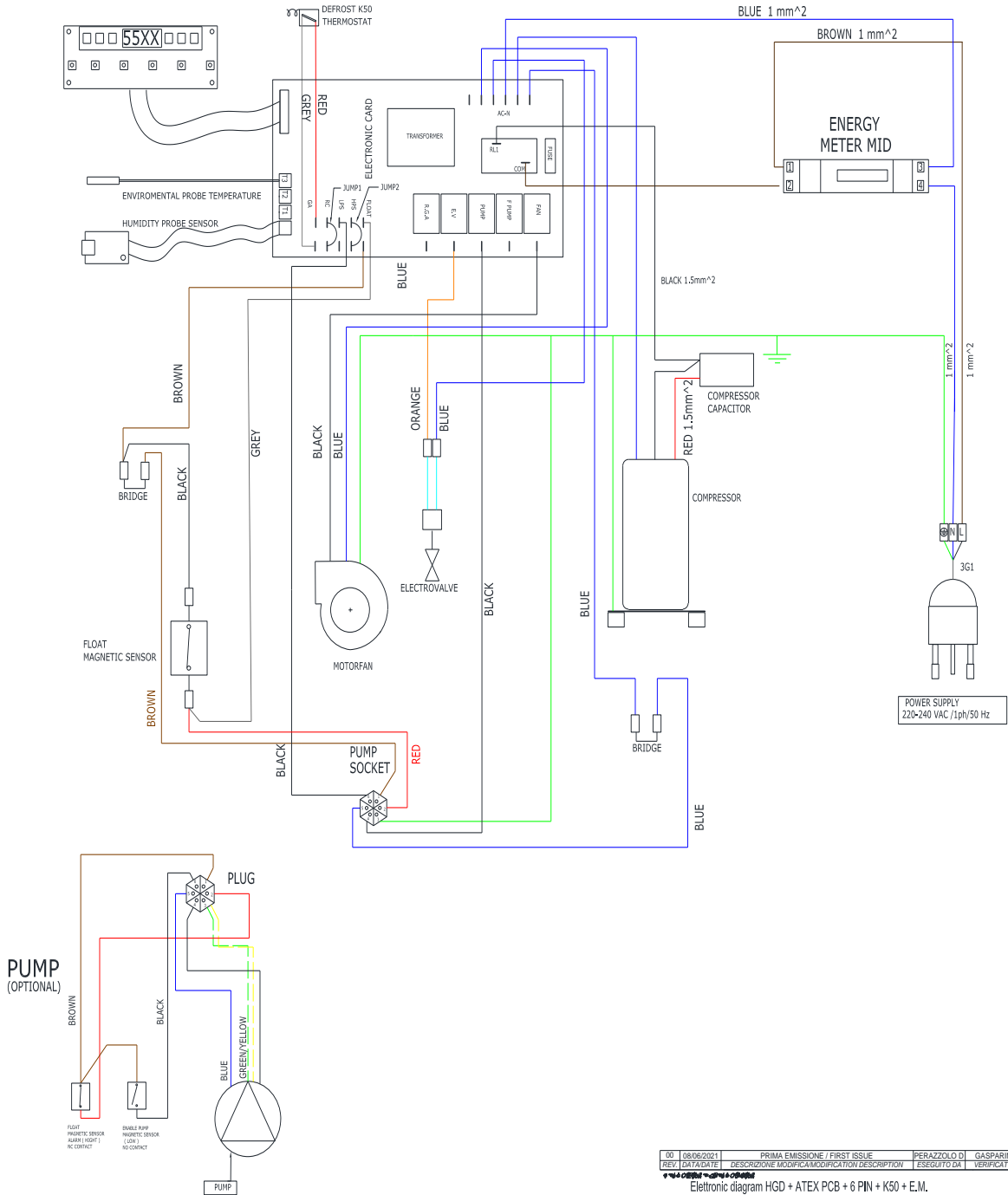

	ENGLISH
1	COMPRESSOR
2	MOTORFAN
3	ELECTROVALVE
4	PLUG
5	ELECTRONIC BOARD
6	DISPLAY
7	TANK SENSOR
8	PUMP CONNECTOR
9	AUTOTRANSFORMER
10	PUMP
11	VOLTAGE SELECTOR
	BROWN
	BLUE
	BLACK
	RED
	GREY
	ORANGE