



E-BIKE

MANUAL

XT600/XT600DM

Read this manual completely before riding electric bicycle



CONTENTS

Profile	01
Structure features and working principle	02
Riding Safety	03
Installation and commissioning	04
Maintenance and repair and troubleshooting	21
Precautions	22
Warranty	23

• Profile

Introduction:

Thank you for choosing our products. To ensure your safety and health, please use this E-bike correctly. It is important to read this entire manual before assembling and using the equipment. Safe and effective use can only be assured if the E-bike is assembled, maintained, and used properly. It is your responsibility to ensure that all users of the E-bike are informed of all warnings and precautions. Before each ride, especially if you may travel a long distance, inspect your e-bike.

IMPORTANT:

- Check the tires for proper inflation and cracks of the tires. Keeping the tires properly inflated and maintained will help prevent flats and damage.
 - Check all cables and cable housings for fraying, breaks, rust, or corrosion and replace if necessary.
 - Check the brakes to make sure that both are working properly. Additionally, check the brake pads for any damage as they will be worn over time and eventually need replacement.
 - Check all nuts and bolts are taut and properly fastened to prevent injury and unnecessary wear and tear on your e-bike.
 - Do not at any time dismantle or assemble any of the above e-bike components!
 - Comply with local laws and regulations when riding this product. Do not ride where prohibited by local laws.
 - To reduce risk of injury, you must read and follow all "CAUTION" and "WARNING" notices in this document. Do not ride at an unsafe speed. Under no circumstance should you ride on roads with motor vehicles.
 - Anyone whose weight is over the limits (see Specifications) is prohibited from riding.
 - Use only approved parts and accessories. Do not modify your E-bike. Modifications to your E-bike could interfere with the operation of the E-bike, could result in serious injury.
 - E-bike cannot be used as off-road vehicles or extreme cycling sports.
- Don't change the default speed setting of the E-bike for your safety concern. Wear a helmet and protective gear when riding.
- This manual is intended as a general guide to your new e-bike and not a comprehensive reference guide. For technical support, including service, maintenance, and repair information, please contact us for more information about our e-bike.

• Structural features and working principle

Working principle of the structure components

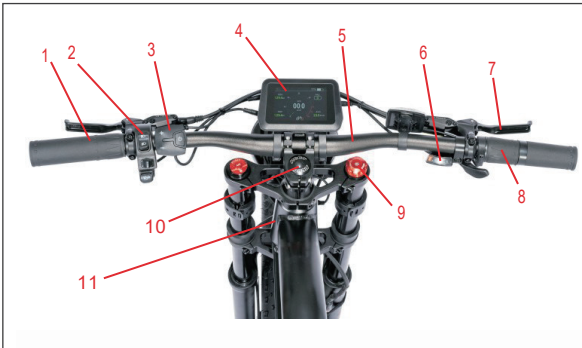

- 1: Grip
- 2: Combination Switch
- 3: Display keys
- 4: Display
- 5: Handlebar
- 6: Gear Control
- 7: Brake Lever
- 8: Throttle Speed control
- 9: Front fork damping switch
- 10: Headset top cover
- 11: Riser



- | | | | |
|----------------|------------------------|-------------------------|---------------------|
| 12: Cables | 16: Disc brake caliper | 20: Tail light | 24: Rear derailleur |
| 13: Headlight | 17: Frame | 21: Rear shock absorber | 25: Chain |
| 14: Front Fork | 18: Battery | 22: Tire | 26: crank set |
| 15: Disc | 19: Saddle | 23: Freewheel | 27: Pedal |

◆ Electric Pedal bicycle is green and environmentally friendly, which functions with pure electric drive combined with electric power, pedal and pedal drive .

◆ Electric drive: Toggle the speed control switch on the handlebar, the controller receives the speed control command and allocates the corresponding power output by the motor

- ◆ Electric power with pedal: When the power is turned on, by stepping on the rotating sprocket, the controller reads the rotation signal of the sprocket sensor, and controls the motor to output the corresponding power.
- ◆ Pedal drive: When the power is OFF you can pedal and Have a Cycling trip

Specification

	XT600	XT600DM
Frame	Aluminum Alloy Full Suspension Frame	Aluminum Alloy Full Suspension Frame
Motor	48V 750W	48V 750W+750W
Battery	48V 25AH	48V 25AH
Max load	85 KM	85KM
Max speed	32 MPH	35 MPH
Tire	26"*4.0 Kenda Snow Fat Tire	26"*4.0 Kenda Snow Fat Tire

• Riding Safety

Operation

- Before riding, it is necessary to check whether the fasteners of the vehicle are loose or abnormal, and whether the electrical components are abnormal. Only when there is no abnormality, you can ride and safely use the Electric Bicycle.
- Electric bicycle users must abide by local traffic laws and regulations and pay attention to driving safety.
- It is recommended to wear a helmet when riding. When riding in rain or snow, the braking distance will be extended. Pay attention to slow down, heavy rain and other bad weather, and try to avoid traveling.
- Do not park electric bicycles in building entrance halls, evacuation corridors, walkways or exits of security doors.
- Electric bicycles should not be charged or parked in residential buildings. When charging, keep away from combustibles. The charging time should not be too long. When charging, the red light of the charger indicates that it is charging, and the green light indicates that the power is fully charged.
- Do not use a powerful faucet to rinse, avoid direct water rinsing the electrical components of the electric bicycle, and try to avoid letting water entering the battery box.
- It is forbidden to use wet hands and touch the metal conductors or touch the live parts of the electric bicycle such as the battery box socket, the battery box connecting wire socket, and the charger power socket and other parts.
- Used batteries should not be dismantled without authorization, and should be handed over to the relevant professional departments for recycling.

• Installation and commissioning

How to install the front wheel



① Find the front wheel, adjust the position of the front wheel hub parts, keep the safety hook inward.



② Align the shift fork with the axle in the center of the wheel, make sure the axles on both sides are inserted into the shift fork, and install the safety hook, washer and screw in sequence.



③ Use a wrench to tighten the screws on both sides in turn.

How to install the Handlebar

◆ Arrange the speed change, brake line pipe, insert the handlebar into the standpipe, lock the top cover screw, align the handlebar and the tire at 90°, and lock the fixing screws on both sides. Torque $\approx 8\text{M.N}$

⚠ Warning: Before each ride, please ensure the following items, frame lock, whether the brake system is normal, and whether the tire is fully inflated to ensure safe riding

◆ Twist the 4 screws at the front of the stem to adjust the angle of the handlebar. The locking sequence is diagonal locking. It is recommended to adjust the brake lever to a comfortable angle of 25-30°.

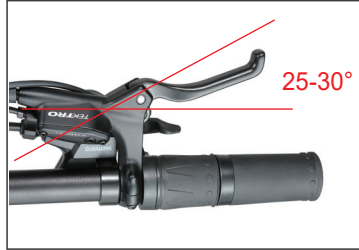

How to install headlight

Plug in the corresponding waterproof cable power plug, red to red, blue to blue, and tighten the screw on the bracket with a tool, the locking torque $\approx 8\text{m.N}$.



How to install the pedal

◆ Before installing the pedals, first distinguish between the crank side and the crank side of the sprocket, (the L mark next to the screw port is the left crank; the R mark is the crank side of the right sprocket), use a 15# wrench to tighten according to the installation direction, and tighten the L side counterclockwise, the R side is clockwise tight, and the pedal locking force is not less than 18N.m.

⚠ Warning: Unlocked pedals may cause a crash, and it is strictly forbidden to ride without locked pedals.

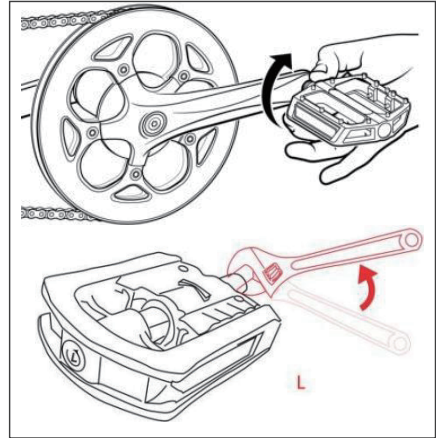
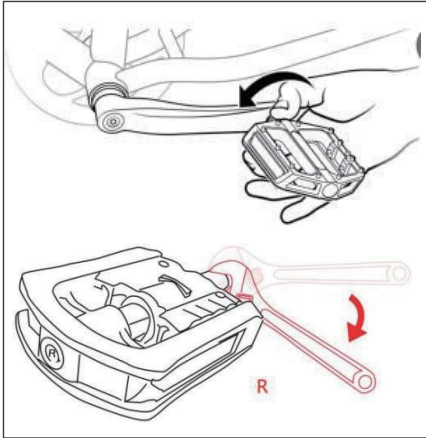
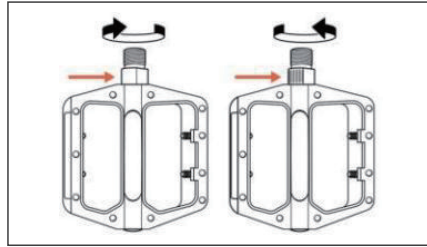

How to install the battery

Align the battery with the guide rail, push down until the bottom touches the back cover, and turn the key clockwise to lock the battery.



How to charge the battery

- ◆ DC charging port on the right side of the battery
- ◆ Power switch, the power switch.
- ◆ at "I" - "is turned on, press the power indicator on the left side of the battery, the indicator lights up, the electric bicycle enters the standby state, the power at "O" is turned off, and all the power sources are turned off. When the battery is pulled out of the rail, the power must be turned off.

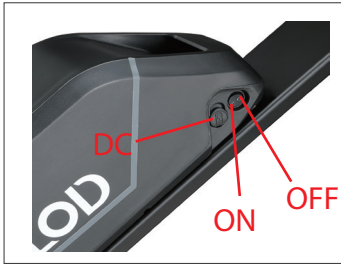

◆ Use the charger with the corresponding voltage and current, insert the DC plug of the charger into the battery, and insert the power plug into the mains socket, the charger light shows red when it is charging, and green when it is fully charged.



How to use the combination switch

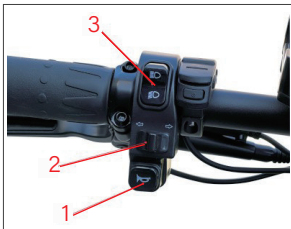

- ① Horn switch
- ② Toggle left and right to turn on the front and rear lights
- ③ After turning on the headlight switch, switch the far and near lights

How to adjust the brakes

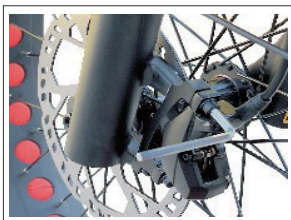

- ① Insert the elbow allen key into the screw hole where the brake is fixed to the frame, press the screw in the direction of "loose left and tighten right", and turn it slightly to the left to loosen the brake slightly.

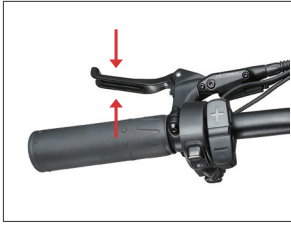

② Then squeeze the brake with your left hand, the purpose is to keep the rear brake close to the brake pad and keep it tight



③ Next, use the elbow allen key to tighten the brake to the right until the brake is firmly fixed, then release the brake, the brake will automatically return to the position and if the direction of the brake pad is correct it will not be worn out

How to adjust the transmission system

- ◆ Use a Phillips screwdriver to adjust the H screw so that the tip of the upper guide is aligned with the outside tip of the smallest freewheel,
- ◆ Move the speed change from the largest freewheel, and use a Phillips screwdriver to adjust the L screw so that the tip of the upper guide is aligned with the outside tip of the largest freewheel
- ◆ Adjust the B tension screw with a Phillips screwdriver, so that the distance between the upper guide wheel and the tooth tip of the largest sprocket should not be less than 6mm
- ◆ Move the smallest disc of the transmission support, tighten the transmission line, and adjust the tightness through the rear fine-tuning screw.

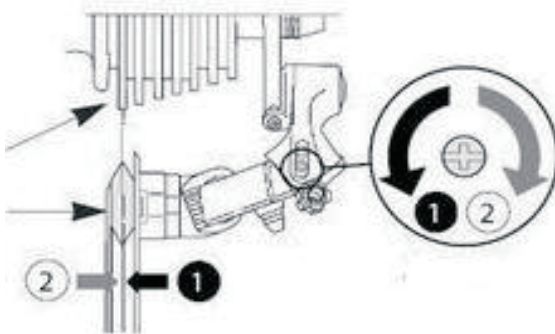

Intelligent display Instructions

Note: Due to the upgrade of the company's products, some of the contents displayed in the products you get may be different from the instructions, but it will not affect your normal use.

Product appearance



The main interface is displayed

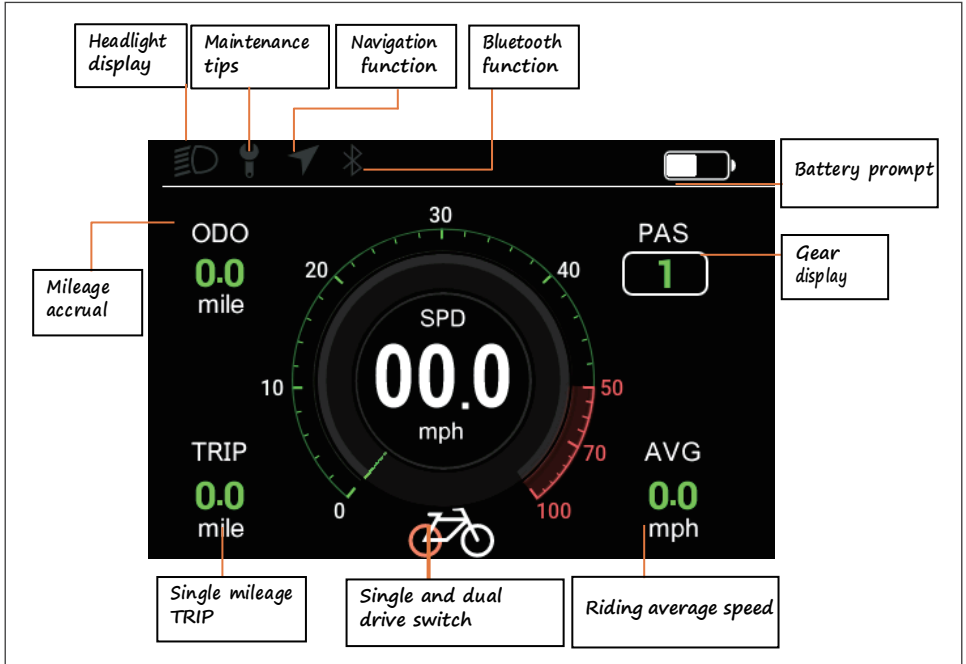

- ◆ Headlight display: display the headlight on/off status, display the logo when the system headlight is on, and hide the logo when it is off;
- ◆ Maintenance tips: display maintenance prompt signs;
- ◆ Navigation function: the mobile phone APP is connected to the Bluetooth of the meter, and the instrument displays the logo when the mobile APP starts navigation
- ◆ Bluetooth function: Bluetooth on/off status display, display identification after successfully connecting the instrument Bluetooth;
- ◆ Battery prompt: prompt real-time power level;
- ◆ Real-time speed display: display real-time speed values;
- ◆ Gear display: display the current gear;
- ◆ Single mileage trip: shows the mileage of this ride;
- ◆ Miles accrued: Displays the number of miles accrued
- ◆ Riding average speed: shows the average riding speed this time;
- ◆ Single and dual drive switch: default rear drive, click the power button to switch between front drive and dual drive

When the mobile phone app is connected to the Bluetooth of the meter, select the destination to start navigation after entering the navigation interface, and the main interface display changes as follows:

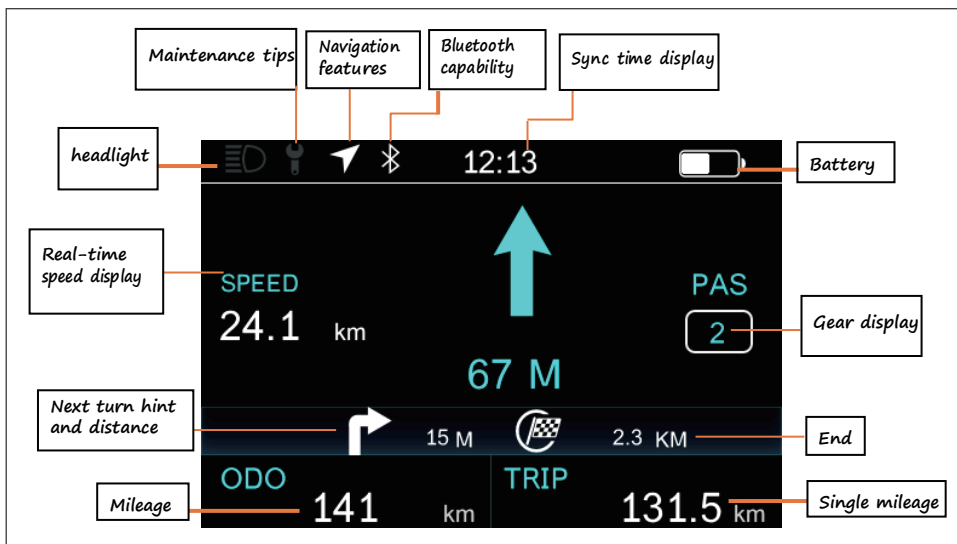

General operations

① Power On/off

After long pressing the "power button", the instrument is powered on to work, and in the stationary state after power-on, long pressing the "power button"  can make the system power down. In the shutdown state, the leakage current of the meter is less than 1uA. The power on and off interface is shown in the following figure.



Note: The boot password is turned on by default, and you need to enter the password 0000 (default, can be modified) when booting

② Assist in gear selection

After entering the main interface, click the "+" key or "-" key to switch the assist gear and change the output power of the motor. The default gear of the instrument is 0-5 gear, booster gear  (or according to order requirements). The assist gear selection interface is shown in the figure below.

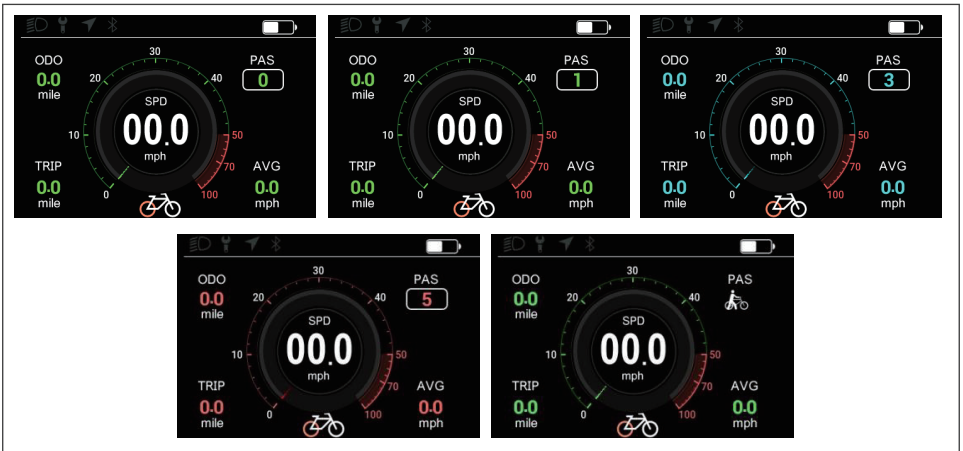

③ Boost mode

When the car body is stationary, tap the "-" key to 0 gear, and tap the "-" key again to display the static boost logo  and then press and hold the "-" key to enter the boost mode. The boost interface is shown in the following figure.

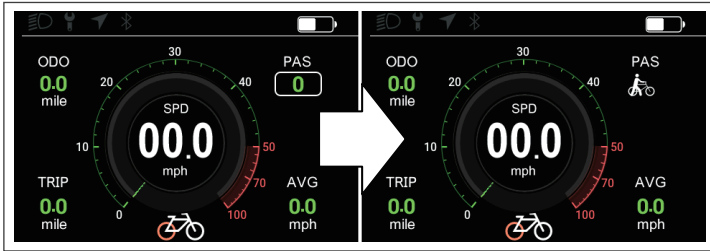

In boost mode, the boost logo is dynamically displayed, the vehicle speed is less than 6km/h, release the button "-" boost state to stop, and restore the static boost status state. No button press within 5s under static boost automatically adjusts to 0 gear.

④ Headlight/backlight switch

◆ The instrument with light sensing function, will automatically turn on the headlights according to the brightness of the external environment, if the headlights are manually switched on and off once, the automatic headlight function is temporarily invalid, and the automatic headlight function returns to normal after the instrument restarts.

◆ Turn on the light: Press and hold the "+" key when the light is turned off, the screen headlight becomes bright, and the controller is notified to turn on the light.

◆ Turn off the light: Long press the "+" key when the light is on, the screen headlight logo does not disappear, but dims, and at the same time notifies the controller to turn off the light. The headlight switch display interface is shown in the figure below.

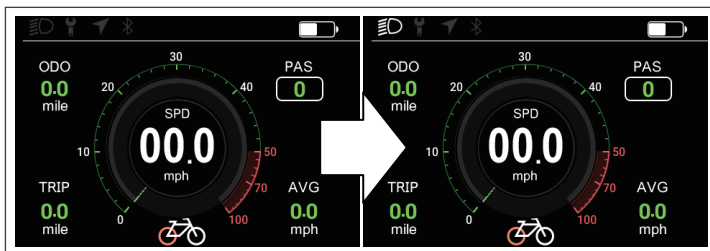

⑤ Single and dual drive mode switching

Turn on the default rear drive, the e-bike is stationary or riding, click the "power button" to switch between front drive, rear drive and dual drive. The mode switch is shown in the following figure.



. Information viewing and setting

Press and hold the keys for 3 seconds to enter the list of setting information, use the "+" key or "-" key to move the cursor up and down, select "Display Setting", "Information", "Language", "Themes", "Password", "Bluetooth", "Auto Off", "Wheel Size", "Display Info" and "Exit", click "Enter". Come in. The function selection interface is shown in the following figure.

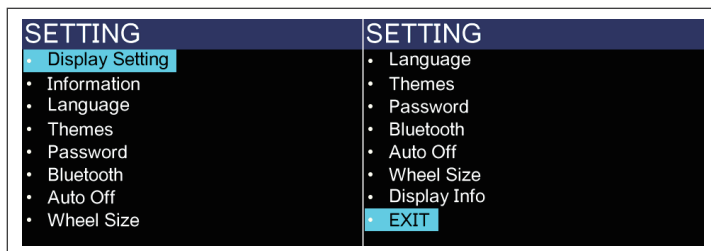

Gauge settings

① Imperial and metric unit conversion

The plus and minus keys are pressed and held for 3 seconds at the same time to enter the setting information list, and the "+" key and "-" key move the cursor to select "Display Setting" menu, click the Power button "Enter" to enter the "Display Setting" menu (password required: 2020), check "Unit", click "Enter" to enter the settings, and after entering the settings, use the "+" key or "-" key to move the cursor and select "Metric" / "Imperial", click "Enter" to save and exit to "Unit", → "Exit" via "Back" "Exit" to the main interface. The unit conversion is shown in the following figure.

Note: Devices are imperial.

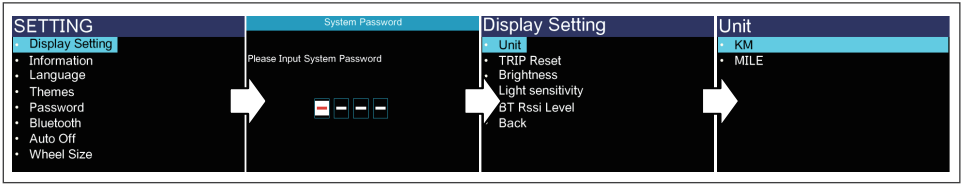

② Single mileage clearance

The plus and minus keys are pressed and held for 3 seconds at the same time to enter the setting information list, and the "+" key and "-" key move the cursor to select "Display Setting" menu, click the Power button "⏻" to enter the "Display Setting" menu (password required: 2020), check "TRIP Reset", click "⏻" to enter the settings, after entering the settings, use the "+" key or "-" key to move the cursor, select "YES"/"NO", click "⏻" to save and exit to "TRIP Reset", → via "Back" Exit" to exit to the main interface. The unit conversion is shown in the following figure.

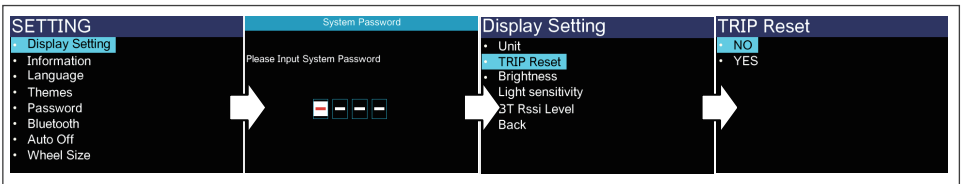

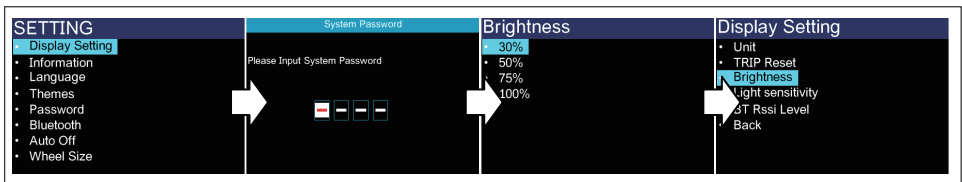

③ Backlight rating

The plus and minus keys simultaneously press and hold for 3 seconds to enter the setting information list, the "+" key and the "-" key move the cursor to select the "Display Setting" menu, and click the "power key" "⏻" to enter "Display Setting" menu (password required: 2020), check "Brightness", click Enter Settings, Use After Entering Settings "+" key or "-" key to move the cursor, move the cursor after entering the settings and select "30%"/"50%"/ "75%"/"100%", click "⏻" to save and exit to "Brightness", "Pass" Back" → "Exit" to exit to the main interface. The unit conversion is shown in the following figure.



④ Light sensitivity

The plus and minus keys simultaneously press and hold for 3 seconds to enter the setting information list, the "+" key and the "-" key move the cursor up and down to select the "Display

Setting" menu, and click the "power key  " to enter" Display Setting" menu (password required: 2020), check "Light sensitivity", click "  " to enter the settings The light sensitivity is "high" by default, select "Low/Mid/High" by moving the cursor, briefly press "  " to save and exit to " Light sensitivity", exit to the main interface through "Back" → "Exit". The sensitivity of light is shown in the figure below.

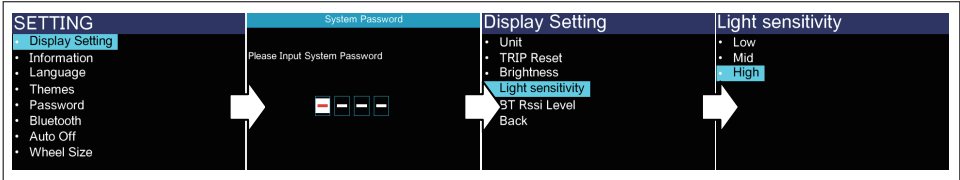



⑤ BT RSSI Level – Bluetooth lock distance level setting

Bluetooth lock distance level: the higher the level, the greater the Bluetooth lock/unlock distance, 1 is near, 5 is far.

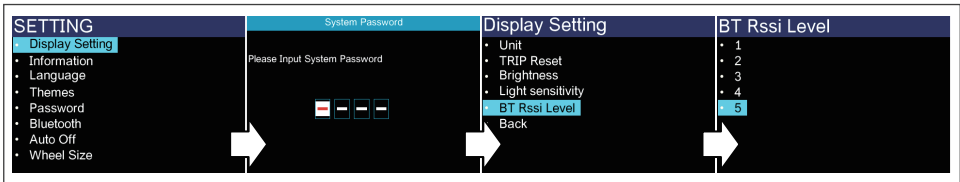
Note: There are slight differences between mobile phones and usage environments.



Information view

◆ Speed limit information - add and subtract keys while pressing and holding for 3 seconds to enter the setting information list, "+" key and "-" key to move the cursor to select "Information" menu, click "Power key  " to enter the " Information" menu (password required: 2020), select "Speed Limit", click "  ", Enter the settings, the speed limit defaults to 60km/h, and the "+" key and "-" key move the cursor left and right to set a new speed limit value Short press "  " to save and exit to "Speed Limit", exit to the main interface through "Back" → "Exit". The speed limit setting is shown in the figure below.

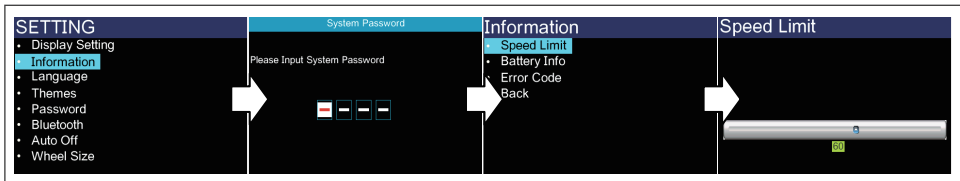

◆ Fault code information - add and subtract keys while pressing and holding for 3 seconds to enter the setting information list, "+" key and "-" key move the cursor to select "Information" menu, click the Power button "⏻" to enter the "Information" menu (password required: 2020), and select "Error Code." Click "⏻" to enter the settings, you can view 7 fault messages, and exit to the main interface through "Back" → "Exit". The following figure shows the fault code information

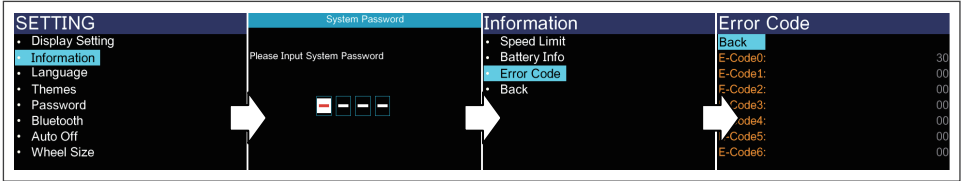

Language selection

BM02U_TQ meter provides 3 Chinese words for users to choose. Add and subtract keys while pressing and holding for 3 seconds to enter the setting information list, use the "+" key or "-" key to move the cursor, select "Language", click "⏻" to enter the language selection interface. at last. Exit to the main interface through "Back" → "Exit". The language selection is shown in the following figure.



Password settings

(1) Turn on/off the password function - click the "⏻" key to enter the list of setting information, use the "+" key or the "-" key to move the cursor, select the "Password" option and click "OK" to enter Password options interface, the cursor checks "Start Password" and clicks "⏻" After confirmation, the interface prompts for a password, at this time use the "+" key or the "-" key to toggle the number "0-9", click "⏻" Switch the digits, after the input is completed, the system prompts to open the password function successfully/close the password function/. The operation steps are shown in the following figure.

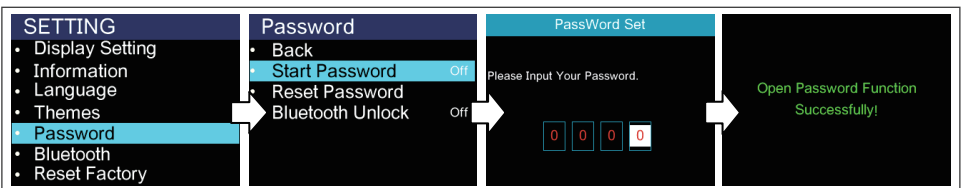

(2) Set and modify the password - click the "⏻" key to enter the list of setting information, use the "+" key or the "-" key to move the cursor up and down select the "Password" option and click "OK" to enter the Password Options interface, after the cursor selects "Reset Password" and clicks "⏻" to confirm

1. The interface prompts "Please enter your old password", at this point use the "+" key or the "-" key to toggle the number "0-9" and click "⏻" "Switch digits",
2. After entering the interface prompt "Please enter your password", then use the "+" key or "-" key to switch the number "0-9", click "⏻" to switch digits,
3. After entering the interface prompt "Please confirm your password", then use the "+" key or "-" key to switch the number "0-9", click "⏻" to switch digits

Note: After the initial password is modified, to enable the display password function, you need to enter a new password to turn it on.

Do not change the initial password unless it is necessary

After the password is successfully modified, the interface automatically jumps to the original settings interface, and exits to the main interface through "Back" → "Exit". The operation steps are shown in the following figure.

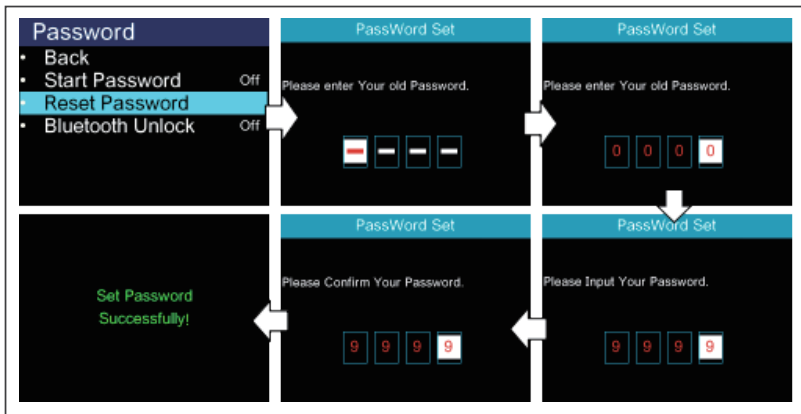

Bluetooth lock settings (Bluetooth unlock is turned on by default)

Click "⏻" key to enter the list of setting information, use the "+" key or "-" key to move the cursor , select the "Password" option and click "⏻"OK" to enter the Password option interface, the cursor selects "Bluetooth Unlock" Click "⏻" to enter the settings, enter the settings and click the "+" key or "-" key to select "On" /Off" , click "⏻" Save Status, Opening the Bluetooth lock when there is no connection to the mobile phone application will pop up the Bluetooth QR code interface, and the "Pas sword" interface will be fed back after the binding is successful, and the "Back" → will be passed Exit" exits to the main interface. The operation steps are shown in the following figure:

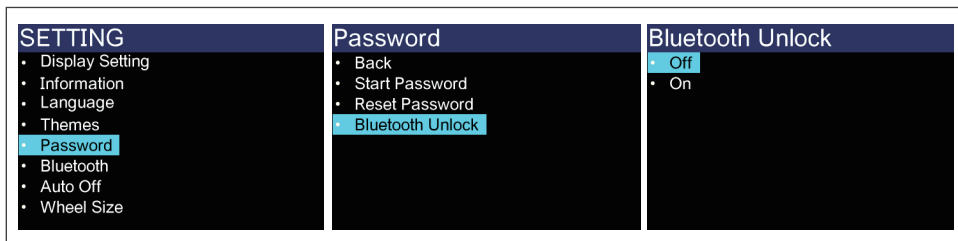

Bluetooth menu

Press the plus and minus keys at the same time for 3 seconds to enter the setting information list, use the "+" key or "-" key to move the cursor, select the "Bluetooth" option and click "OK". Enter the Bluetooth QR code interface, you can scan the QR code through the mobile phone APP to bind the device, after binding the device, the device interface will automatically jump to the main interface. The operation steps are shown in the following figure

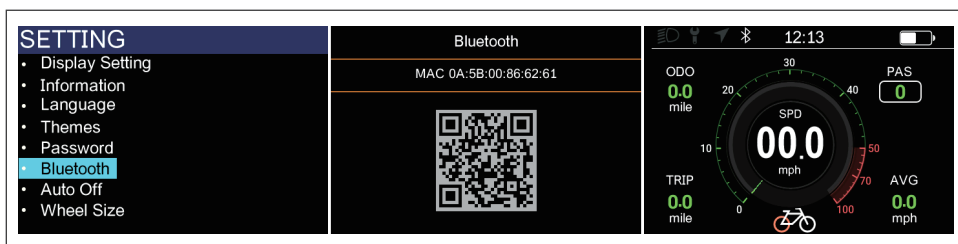

Note: After disconnecting Bluetooth, it will not affect the time to continue timing, only disconnect Bluetooth and restart the meter will clear the time

Automatic shutdown function

Press the plus or minus keys at the same time for 3 seconds to enter the setting information list, use the "+" key or "-" key to move the cursor up and down, select "Auto Off", and click "OK". Enter the setting interface, the options are "OFF", "1Min", "10Min", and the default automatic shutdown time is 5Min, OFF means to turn off the automatic shutdown function, use the "+" key or "-" key to move the cursor up and down to select The required automatic shutdown time, click "OK" to save and exit to the "Auto Off" menu, exit to the main interface through "Back" → "Exit".

Note: 1. Any operation performed during the automatic shutdown time will be re-timed, and the inaction will not be turned off until the set time is reached.
 2. After the App connects to the instrument Bluetooth, the meter will not automatically shut down
 3. When riding, the gauge does not automatically turn off

Wheel diameter setting

Press the plus or minus keys at the same time for 3 seconds to enter the setting information list, use the "+" key or "-" key to move the cursor, select "Wheel Size", click "⏻" "Go into the settings, the wheel diameter defaults to 28 inch, and the range can be set from 20 inch-29 inch. After the setting is complete, exit to the main interface through "Back" → "Exit". As shown in the following figure.

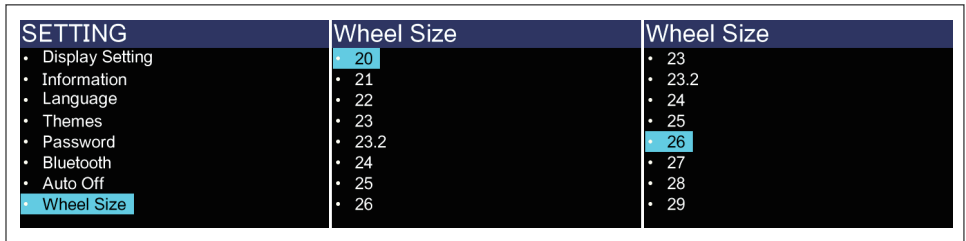

Gauge information

Press the plus or minus keys at the same time for 3 seconds to enter the setting information list, use the "+" key or "-" key to move the cursor up and down, select "Display Info", click "⏻" OK. The instrument interface displays the software and hardware version number of the instrument, (the software and hardware version number may change due to different batches of the product) exit to the main interface through "Back" → "Exit".

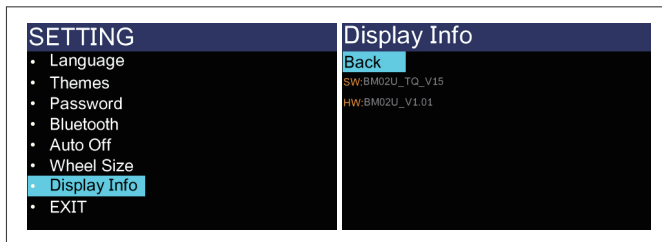

Error Code Solution

Error code	Description of the fault	Troubleshooting methods
"02"	Brake handle failure	Stop riding and check that the brakes are back in place and damaged
"04"	The speed control put has no homing	Check that the speed control handle is in position
"05"	Speed regulation put failure	Check the speed control handle
"06"	Undervoltage protection status	Check the battery voltage
"07"	Overvoltage protection	Check the battery voltage

"08"	The motor Hall signal line is faulty	Check the motor module
"09"	Motor phase line failure	Check the motor module
"10"	The temperature inside the motor is too high	Check the motor
"11"	The motor temperature sensor is faulty	Stop riding
"12"	Current sensor failure	Check the controller
"13"	Temperature failure inside the battery	Check the battery
"14"	The temperature inside the controller is too high	Check the controller
"15"	Controller temperature sensor failure	Stop riding
"16"	Controller failure	Stop riding
"17"	Abnormal brakes	Stop riding and check that the brakes are back in place and damaged
"21"	Bafang: The speed sensor is faulty KM5S: Current abnormality	Bafang: Check the installation location of the speed sensor KM5S: Check the controller plugin
"22"	KM5S: Handle abnormal	Check the speed control handle
"23"	KM5S: Motor phase loss	Check the motor
"24"	KM5S: Motor Hall abnormality	Check the motor
"25"	Bafang: Torque sensor torque signal failure KM5S: Abnormal brake	Bafang: Check the torque KM5S: Stop riding
"26"	Torque sensor speed signal failure	Check the torque
"29"	Controller communication failure	Check the controller connector
"30"	Instrument communication failure	Check the controller connector
"27"	Controller overcurrent	Check the controller
"33"	Brake detection circuit failure	Check the controller
"35"	The 15V power supply detects faults	Check the controller
"36"	Press the key to detect circuit failures	Check the controller
"37"	Watchdog malfunction	Check the controller
"61"	The transmission is stuck	Check the transmission
"62"	The transmission cannot be reset	Check the transmission
"81"	Bluetooth module failure	Check Bluetooth
"41"	The total voltage is too high	Check the battery
"42"	The total voltage is too low	Check the battery
"43"	The total current is too large	Check the battery
"44"	The monomer voltage is too high	Check the battery
"45"	Excessive temperature (battery)	Check the battery
"46"	Temperature too low (battery)	Check the battery
"47"	The SOC is too high (battery).	Check the battery
"48"	How low the SOC is (battery).	Check the battery
"71"	The electronic lock is stuck	Check the electronic lock

• Maintenance and Repair and Troubleshooting

Daily Maintenance

- ◆ Dear users In: order to prolong the service life of the Electric Bicycle and enable it to drive safely and comfortably, please check it regularly. When the electric bicycle is stopped and used for a long time, it should also be checked regularly. When the Electric Bicycle running for 300KM, it should be checked and maintained.
- ◆ Check whether the brake clearance is within the specified range (10-15MM). If it is not correct, it should be adjusted. Serious wear of the brake pads (more than 2/3) requires timely replacement.
- ◆ Electric bicycle tires are often in contact with the ground, and any stones, glass, and nails on the ground will cause certain damage to the electric bicycle. Therefore, you must pay attention to inspection when driving. In addition, you should always check whether there are obvious cracks on the ground surface and any cracks, damages of tires. Whether nails, glass and other objects have penetrated, and whether there is abnormal wear and tear caused by long-term driving.
- ◆ The battery is the key part of the electric bicycle, it should be used correctly and properly protected, and users should be able to charge it as needed, if the daily travel distance is greater than 20KM, it should be charged every day After the mileage of 100KM, you need to add special chain oil to the chain.
- ◆ Riding without oil will wear out the chain, sprocket and freewheel.
- ◆ After the chain is used for 10000KM, there will be wear and tear. The length of the chain will affect the smooth speed change. Use the chain ruler to measure the wear and tear and need to be replaced in time.
- ◆ When you come back from riding in rainy days, you need to wipe the water traces on the electric bicycle in time to avoid acid rain from corroding accessories
- ◆ When the battery is in use, it is forbidden to over-discharge, under-charge, and over-charge, so as not to damage the battery and shorten the service life of the battery.

Troubleshooting

Item No.	Error	Reasons	Solutions
1	Speed regulation failure or maximum speed is low	1. The battery voltage is too low 2.The speed control handle is continuously loose 3.The spring in the speed control handle is stuck or failed	1.Fully charge the battery 2.Step up after inspection 3.Replace speed throttle

2	Power on the motor does not work	1.The motor connecting wire is loose 2.Power off brake handle failure 3.Motor hub wire plug loose or damaged	1.Tighten the cable 2.Check whether the power cord of the brake lever is disconnected 3.Tighten the link plug or replace
3	Insufficient range on a single charge	1.Insufficient tires pressure; insufficient charging, charger failure 2.Battery aging; many uphill; strong headwind; frequent brake activation; heavy load and low air temperature	1.Sufficient gas; sufficient Charge or , whether the charger connector is in poor contact, 2.Replace battery; pedal assist recommended
4	Charger not charging	The charger plug is disconnected or the connection between the plug and the socket is loose	Tighten socket inserts; replace fuses, solder connecting wires
5	The battery is fully charged but no voltage is displayed, the hub motor cannot be used	1.Starting the motor when the voltage is lower than 30V 2.The battery switch cable is disconnected 3.The display plug-in comes off 4.Controller failure	1.Replace the battery with a new one 2.Reconnect/tighten 3.Replace the display 4.Replace the controller

• Precautions

Notice:

- ◆ Users must follow the instruction manual during charging the battery.
- ◆ Reminder: The original charger must be used.
- ◆ Pay attention to the type and applicable voltage of the batteries that the charger can charge, and it is strictly forbidden to mix them.
- ◆ When charging, it should be placed in a ventilated environment. It is strictly forbidden to charge in a confined space or in a hot sun and high temperature environment. Do not place the charger in the saddle and tail box for charging.
- ◆ When charging, plug in the battery first, then plug in the power supply, cut off the power supply first, and then pull out the power plug.
- ◆ When the green light is on, the power supply should be cut off in time, and it is forbidden to connect the charger to the AC power supply with no load for a long time without charging.
- ◆ During the charging process, if the indicator light is abnormal, or there is a peculiar smell or the case of the charger/discharger is overheated, the charging should be stopped immediately, and the charger/discharger should be repaired or replaced.

◆ During the use and storage of the charger, avoid the entry of foreign objects, especially avoid the inflow of water or other liquids, so as to avoid short circuit inside the charger, try not to carry the charger with the car, if it needs to be carried, it should be Placed in the toolbox after shock absorption treatment.

◆ In heavy rainy weather, avoid the rear wheel motor soaking in water during riding. The water flowing over the motor shaft will easily lead to water ingress, resulting in damage to the motor and controller, which is not under the scope of Guarantee.

•Warranty

If the product has problem with the following forms during the warranty period, we will provide customer service as part of the product quality guarantee.

Accessories	Quality problem	Warranty period	Service content
Motor	Motor will not be able to use	12 months	Free delivery of parts
Accelerator	Natural conditions (such as impact force cannot be used except damage)	12 months	Free delivery of parts
Controller	Failure occurs under normal use	12 months	Free delivery of parts
Charger	Failure occurs under normal use	12 months	Free delivery of parts
Lithium Battery	Discharge under normal use	12 months	Free delivery of parts

Notes:

If the above issues occur during the protection period, please contact us and send us photos or videos of the defective parts. If we confirm that the fault is caused by the quality of the product itself we will send you the parts that are needed replaced for free.

This warranty does not cover:

Products used other than in accordance with their intended use or the use instructions / parameters set out in the relevant User Manual;

Products that have been misused, involved in an accident, neglected or abused;

Products used for competition including but not limited to racing or trials;

Products used for rental purposes or any commercial application;

Products that have been improperly assembled;

Products that have not been maintained or serviced in accordance with the instructions set out in the relevant User Manual;

Products altered or modified in any way from the manufacturer's specifications; Parts requiring replacement or repair as a result of normal wear and tear.

****The pictures in the instruction manual are only for demonstration , please refer to the actual electric bicycle received!**

Company: Miami International Co., Ltd

Address: 5604 Huddart Ave, Arcadia, CA91006

Website: <https://www.meelod.com>

Email: services@meelod.com (Buy from meelod.com)

meelod.service@gdtaiqi.com (Buy from Amazon)