

# INSTALLATION AND OPERATING INSTRUCTIONS

## MOLECULAR WATER PURIFICATION AND TREATMENT SYSTEM



**VISANTO**

<b>1. BEFORE YOU INSTALL THE MOLECULAR WATER PURIFICATION AND TREATMENT SYSTEM</b>	3
<b>2. WORK SAFETY CONDITIONS</b>	3
<b>3. HOW OPERATES THE MOLECULAR WATER PURIFICATION AND TREATMENT SYSTEM</b>	5
<b>4. BASIC TECHNICAL PARAMETERS OF THE SYSTEM</b>	6
<b>5. WHERE TO MOUNT THE MOLECULAR WATER PURIFICATION AND TREATMENT SYSTEM?</b>	7
5.1 Checklist	7
5.2 Required tools and materials	7
<b>6. SOME RELEVANT INSTALLATION REMARKS</b>	8
6.1 Connecting to a standard JG type quick connector	8
6.2 Disconnecting the standard JG type quick connector	8
<b>7. FOUR STEPS OF THE SYSTEM INSTALLATION PROCESS</b>	
Installation of the membrane in the casing	8
7.1 Step 1: Cold water source connection	8
7.1.1 Method 1: 3/4" or 1/2" water connection - Connecting at the water source tap	9
7.1.2 Method 2: 3/8" or 1/2" water connection - Connecting at the water source	9
7.2 Step 2: Spout installation	10
7.2.1 Drilling a hole in the sink of porcelain / stainless steel / aluminum	10
7.3 Step 3: Drain connection installation	11
7.4 Step 4: Tank valve installation	11
7.5.1 Step 5: Prefilters flushing	12
7.5.2 Rinsing end cartridges	12
7.5.3 Pressure control check	12
<b>8. OPERATION AND MAINTENANCE OF THE MOLECULAR WATER PURIFICATION AND TREATMENT SYSTEM</b>	13
8.1 Replacement of pre-treatment cartridges	13
8.2 The membrane installation/replacement	13
8.3 Final cartridges replacement.	15
<b>9. MAINTENANCE OF THE SYSTEM AND PROCEDURE IN THE EVENT OF FAILURE</b>	16
<b>10. WIRING DIAGRAM AND PARTS LIST OF THE MOLECULAR WATER PURIFICATION AND TREATMENT SYSTEM</b>	17
<b>11. MIM-2 MAGNETIC PULSER</b>	18
<b>12. THE MOLECULAR WATER PURIFICATION AND TREATMENT SYSTEM INSTALLATION SHEET</b>	19
13. Guarantee conditions	20

Thank you for choosing Our Molecular Water Purification And Treatment System. You have become a user of the perfect system, which with high efficiency:

- removes the most organic and inorganic contaminants,
- lowers the potential of the redox (oxidation-reduction potential),
- increases the pH of water (alkaline water),
- structures the water,
- restores lost magnetic memory of water, ordering its dipoles,
- improves the taste and odour of water.

The system uses the pressure of the household water system. The pressurized water flows through the molecular membrane which retains contaminations. The purified water is directed into the tank, and from the tank it flows into the spout. Instead, the contaminations are directed to the drain of the water drainage system.

The system consists of a high-quality initial and final cartridges. The initial cartridges stop the mechanical, organic and chlorine contaminations. The final cartridges improve the taste and odour of water, eliminate the trace gaseous substances that can penetrate through the molecular membrane. The shut-off, four-way valve shuts off the water supply when the tank is full, and the spout is closed.

The Molecular Water Purification and Treatment System will provide you with an inexhaustible source of crystal clear water perfect for drinking, cooking and other purposes. Having at hand a source of high quality water eliminates the need to purchase bottled water.

The Molecular Water Purification and Treatment System includes a pressure tank with a volume of 12 dm<sup>3</sup>.

## IMPORTANT SYMBOLS !



**A symbol indicating places and steps for which special attention should be paid.**



**A symbol for the unconditional need to respect the steps for the security reasons, or in connection with the occurrence of threat of damage to the device.**



**Reference to other places in the instructions where the discussed function is described in more detail.**



**These chapters are intended primarily for installation and maintenance staff.**



**NOTE:** Ice machine with integrated refrigerator may not work properly in the case of cooperation with the Molecular Water Purification and Treatment System installed and supplied from a source of water the parameters of which are not within the pressure range (2.2 - 6.0 bar), referred to on page 6.



**CHECK THE WATER SUPPLY:** The source of COLD water supply to the system must meet certain conditions. Check the specification on page 6. If the source water does not meet the conditions, the Molecular Water Purification and Treatment System will not produce good quality water and the membrane and cartridges lives will be significantly reduced.



**NOTE:** The chlorine dissolved in the water can damage the membrane. The initial cartridges remove chlorine to the level indicated in the specification on page 6. It is important that initial cartridges are replaced at intervals recommended on page 15, par. 9.



**NOTE:** Rinse the membrane and the final cartridges before the first consumption of water from the Molecular Water Purification and Treatment System. The membrane is protected with a food preservative, which must be rinsed before the first intake of water from the system. This procedure is described on page 12 (par. 7.5)



Carefully read all the steps and instructions regarding the installation and use of the system. Carefully follow the steps for proper installation. Knowing the content of these instructions will let you take full advantage of the benefits of your system.



**DO NOT** attempt to use the system for the production of drinking water from the sources not intended for this purpose. Do not use the system with microbiologically contaminated water or with water of unknown parameters without submitting it to disinfection before or after treatment.



Consult your local sanitary and other regulations related to the water system connections. Follow their instructions when installing. Adhere to the local regulations when they differ from these instructions. This system works with water pressure between 2.2 bar (32 psi) (minimum) and 6.0 bar (87 psi) (maximum). If the pressure exceeds 6.0 bar (87 psi), a water pressure reducer must be installed.



Do not install the system outdoors or under conditions of extremely high or low temperatures. The temperature of the water supplied to the system should be between 4 ° C and 38 ° C.

**Do not connect the system to the source of hot water.**



The membrane is protected with a food preservative during its storage and transport. Make sure that it was rinsed according to the instructions on page 12 (par. 7.5).

The wiring diagram and parts list of the system is on p. 16, par. 10.

#### **INITIAL MECHANICAL CARTRIDGE.**

Cold water from the supply pipe flows through the sediment cartridge made of high quality polypropylene cord that stops mechanical contaminations such as sand, silt, rust, sludge and other deposits.

#### **INITIAL MECHANICAL CARTRIDGE WITH ACTIVE CARBON**

The cartridge is made of polypropylene cord and granular activated carbon. The activated carbon removes chlorine and its derivatives, lead, toxic heavy metals, pesticides, detergents, phenols and organic compounds. The polypropylene cord removes minor mechanical contaminations.

#### **MOLECULAR MEMBRANE**

The membrane is a barrier for organic and inorganic contaminants, water-soluble solids, heavy metals, radioactive and carcinogenic elements. The membrane is only permeable to water molecules, since it has pores with diameter of 0.0001 micron. The treated water is collected in the tank, and then directed to final cartridges and to spout. Dirty water is, through the flow restrictor, directed to drain.

#### **FINAL CARTRIDGE WITH ACTIVE CARBON**

Water, after leaving the tank, flows through the final cartridge with high quality active carbon. The cartridge improves the taste and smell of water.

#### **FINAL CARTRIDGE – STRUCTURE + H<sub>2</sub> + ORP + pH**

After the final cartridge with active carbon the water flows through special Redox cartridge. The cartridge saturates water with minerals. The cartridge contains natural mineralizing deposit that decreases the ORP potential (oxidation- reduction potential), saturates the water with hydrogen molecules and increases the pH (alkalizing effect). The cartridge improves the taste of water.

#### **FINAL MINERALIZING CARTRIDGE**

The cartridge saturates water with minerals. The cartridges contain natural minerals, the appropriate fragmentation of which causes their dissolution in water. The water is alkaline after using the cartridge.

#### **WATER TANK**

The water tank, depending on the water pressure in the water supply network, may fit up to 8 liters (total capacity of the tank is 12 liters). When the tank is full of water, the membrane inside the tank maintains the water pressure at 2.5-3.0 bar. This pressure provides for fast flow of water through the final cartridges to the spout. When the tank is empty the pressure within the tank is 0.3 - 0,5 bar (5÷7 psi).

## SHUTOFF VALVE

The system is equipped with a shut-off valve which at the time of filling the tank and closing of the spout valve, closes off the water supply to the system. When the pressure of water in the tank drops, the shut-off valve opens and the water supply system is again supplied from the network.

## FLOW RESTRICTOR

Flow restrictor limits the amount of water flowing from the membrane to drain, thus increasing the pressure on the membrane allowing the process of reverse osmosis to take place.

VISANTO	
Height	43.0 [cm]
Width	33.0 [cm]
Depth	12.0 [cm]
Supplying water pressure range	2.2 - 6.0 [Bar]
The supply water temperature range	4 - 38 [°C]
Maximum TDS	1500 ppm (*)
Maximum concentration of Chlorine	0.3 ppm
The supplying water pH range	2 - 11
Performance	291 dm <sup>3</sup> / 24h 75 GPD (gallons per day) (**)
Salt reduction degree	95 – 97 %
Total volume of the water tank	12.0 dm <sup>3</sup>
Maximum volume of water in the tank	8.0 dm <sup>3</sup>

(\*) - water hardness < 17 mg CaCO<sub>3</sub>

- turbidity < 1NTU
- SDI (colloidal index) <5
- Fe < 0.01 mg/l
- Mn < 0.05 mg/l
- Si < 25 mg/l

(\*\*) At a pressure of 4 [Bar], water temperature of – 25 [°C] and TDS = 250 ppm

The Molecular Water Purification and Treatment System is adapted for mounting in a kitchen sink or a bathroom washbasin cabinet. The system can be wall mounted or free standing next to the water tank. The spout should be installed in the sink, next to the kitchen countertop or in a special holder on the wall.

The system can also be mounted at some distance from the spout, having regard to the safety conditions described on page 4. Close distance to the source of water and sewage systems necessary.

## **WATER SOURCE**

To bring the water to the system the water connection supplied with the system must be mounted (page 8, p.7.1.).

## **WATER DRAIN OUTLET TO THE SEWAGE SYSTEM**

There must be a suitable outlet for dirty water coming from the Molecular System rinsing. When mounting at distance, the drain points may include: floor drain, washing machine drain, sewage pipe, sewage manhole, etc. The drain connection supplied with the system allows you to connect the system to a discharge pipe located under the sink.

**NOTE:** Length of the hoses supplied with the system allows to move the system freely during the maintenance. If, for aesthetic reasons, those hoses are shortened, then the system must be left at the site of its installation during the maintenance. Consideration should be given to access to the system during maintenance.

### **5.1 CHECKLIST:**

1. Molecular Water Purification and Treatment System including water tank.
2. ¼ inch connection hoses
3. Installation kit, tank valve, drain connection, water connection, spout with a set of seals.
4. Installation and operating instructions.

### **5.2 REQUIRED TOOLS AND MATERIALS:**

1. Driller with variable speed.
2. Ø 4, Ø 6, Ø 10, Ø 13 drills.
3. No. 17, 24, 32 open wrenches, or master wrench, pliers.
4. Screwdriver.
5. Technical knife or scissors.
6. Teflon tape.



In case of a system including JG type quick connectors, introducing the connecting hoses to each connector is enough.

### 6.1 Connecting to a standard JG type quick connector

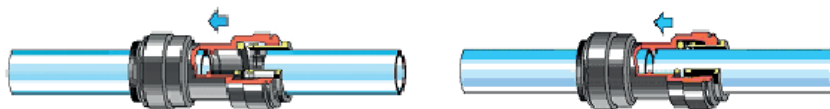

Introduce the hose into the connector until it stops. The clamping ring has blades made of stainless steel, which hold the hose, while the inner seal provides for the connection tightness.

Pull the hose to see if it is secured. A good practice is to test the system under pressure before leaving the place of installation.

### 6.2 Removing the standard JG type quick connector

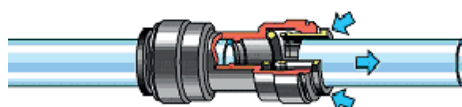

Make sure that the water in the system is not under pressure. Press the clamping ring in the direction of the connector front. Pull the hose while holding the ring. The connector can be reused.



## Installation of the membrane in the casing

**NOTE:** The membrane is hermetically packaged and protected with a food preservative. During installation, cut the transparent film on the side of the tube with two o-rings, lubricate O-rings with Vaseline and insert through the protective film, without touching the membrane with your fingers. (DO NOT REMOVE THE BLUE FILM FROM THE MEMBRANE - IT IS A COMPONENT OF THE MEMBRANE)

The membrane should be placed in its casing before installing the system. The membrane installation is described **on page 13**, paragraph 8.2.

### 7.1 STEP 1: COLD WATER SOURCE CONNECTION

There are several ways to connect the system into the main water source. Depending on the local standards, the purchased system may comprise the water supply connectors of 3/8", 1/2" and 3/4". Select one of the two methods described below of connecting the system to the water source, depending on the connection.

**NOTE: The Molecular Water Purification and Treatment System can only be connected to a source of cold water!**

Do not connect the system to the source of hot water. Hot water can severely damage the system.



7.1.1 METHOD 1: 3/4" or 1/2" water connection - Connecting at the water tap

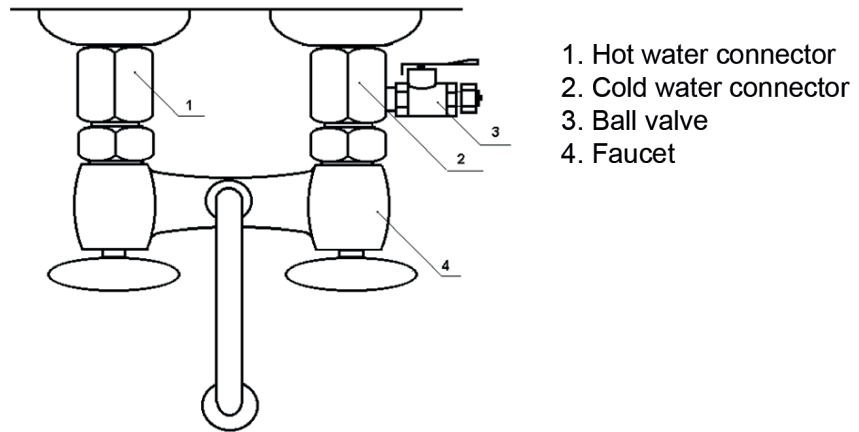

1. Locate the valves of hot and cold water under the sink , and then close them. Open the hot and cold water faucet in the tap to drain water and to ensure that the water supply was cut off.
2. Remove the screws connecting the tap and remove the tap. Then apply the seal and install the water connection elements, bearing in mind that the element with a hole should be installed on the source of cold water. Tighten fully.
3. Wind a Teflon tape to the valve threads, screw the ball valve into the bore of the cold water connection element.
4. Attach the tap to the water connection elements. Close the hot and cold water faucet in the tap, and the ball valve connection, and then open the inlet of hot and cold water to check the tightness of connections.
5. The ball valve must be connected to the system with a 1/4" flexible hose which is attached to the kit. the valves of hot and cold water under the sink , and then close them.

7.1.2 METHOD 2: 3/8" or 1/2" water connection - Connecting at the water source

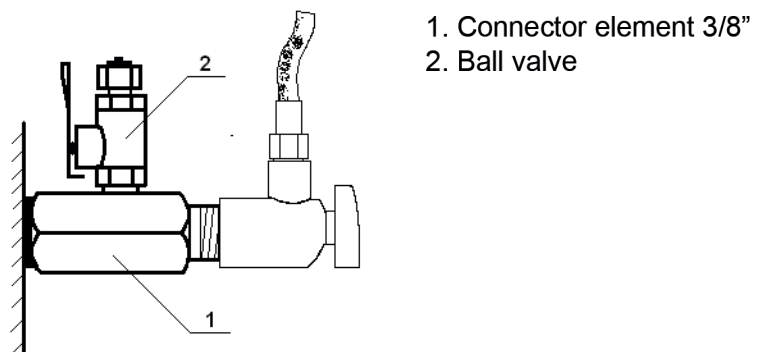

1. Locate the cold water valve under the sink (if the connection is mounted after of the valve), or the main shutoff valve (if the connection is installed before the cold water valve, as in the diagram), then tighten the water supply. Open the cold water valve in the tap to drain the water.

2. Unscrew the nut of connection hose or the shut-off valve. Apply the seal and mount the connection element, tighten until it stops.
3. Wind a Teflon tape to the valve threads, screw the ball valve into the bore of the cold water connection element.
4. Connect the connection hose to the connection element or install the shut-off valve. Close the ball valve, and then open the main shut-off valve or the cold water valve to check the tightness of connections.
5. The ball valve must be connected with a flexible hose to 1/4" system, which is supplied in the kit.

## **7.2 STEP 2: SPOUT INSTALLATION**

1. The spout should be installed with regard to aesthetics, functionality and comfort. For this purpose, a flat surface for secure attachment is necessary. Check also whether the space under the sink allows for carrying out assembly of the spout at the desired location.
2. In case of lack of an adequate space for mounting the spout from the top side of the sink, it can be mounted on the countertop next to the sink. Check the limitations caused by the thickness of the cabinets and drawers wall, brackets, etc. If the countertop plate is made of ceramic, then the necessary hole should be made by the method used for drilling holes in porcelain sinks.

**NOTE:** The process of drilling a hole in the sink requires attention and care. The sink of porcelain may be crashed, if the operation is carried out carelessly.

### **7.2.1 Drilling a hole in the sink of porcelain / stainless steel / aluminum**

To mount the spout, a hole with a diameter of Ø 13 mm must be made. It is recommended to use a special drill bit when drilling in porcelain. Use the safety glasses and be careful, while following the below steps, when making the hole in the sink or countertop:

1. Stick the a slice of the mounting tape (the maximum thickness of the countertop to which the spout may be mounted is 60 [mm]), in the place where the whole is to be drilled.
2. Perform slowly the hole in a designated place, using a driller with adjustable speed, including a drill bit of Ø 6 mm. Use oil to cool the drill bit during drilling, if necessary.
3. Enlarge the hole using a drill bit with a diameter of Ø 10 mm.
4. Enlarge the hole using a drill bit with a diameter of Ø 13 mm.  
Drill slowly with a well lubricated drill bit.
5. Clean and/or grind the area of drilling, and then remove the mounting tape.

**NOTE:** pieces of metal on porcelain cause rapid formation of stains.

6. Move the rosette and the rubber seal though spout thread, according to the diagram (p.10).
7. Put plastic and a metal washers on the underside of the sink, and then tighten the nut until it stops.

8. After the faucet installation, insert the nut that fixes one hose on another, then insert the clamping ring that fixes one hose on another and push the pin.
9. Tighten the nut that secures the hose until it stops.
10. The other free end of the 1/4 „ hose must be connected to the connector marked as FAUCET.

### 7.3 STEP 3: DRAIN CONNECTION INSTALLATION

1. Drain connection fits most standard drain pipes with a diameter of 50 mm. The connection should be mounted above the trap on the vertical or horizontal pipe connecting the sink drains.
2. Unscrew the clamping screws and put the front half of the drain connection at the point of its installation. Mark the spot where the drainage hole is to be made, and then drill the drainage hole with a drill bit with 4 mm diameter through the connection element hole. Do not install the drain connection close to the waste settler, because it can lead to the drain clogging. Before performing the hole and installation of the connection the future course of the 1/4” hose must also be considered.
3. Expand the drill hole In the place marked in picture below, with a drill bit with diameter of 6 mm in the drain pipe.
4. Remove the circular central part and the paper protection from a foam seal supplied with the drain connection, Attach it to the drain pipe in such a way that the hole in the seal coincides with the hole in the pipe and the clamp.
5. Position the front part of the drain connection with the executed hole using a  $\varnothing$  4 mm drill or a narrow screwdriver. Then apply the second element of the connection with clamp screws to connect together the two elements of the connection. Tighten the screws evenly.
6. Connect one end of 1/4” hose to the drain connection, and the other one to the connector marked as DRAIN.

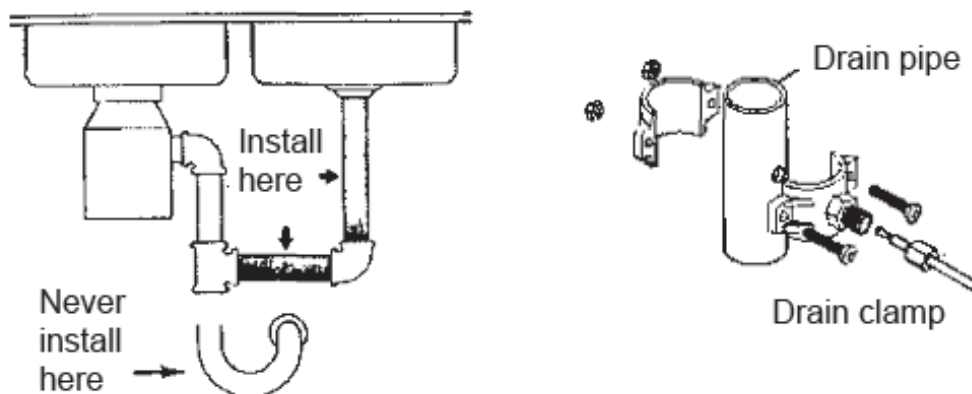

### 7.4 STEP 4: TANK VALVE INSTALLATION

1. Tighten the tank valve until it stops, in case of a plastic tank.
2. In the case of a metal or metal-plastic thread tank, wrap the Teflon tape and the screw the tank valve.

### **7.5.1 STEP 5: PREFILTERS FLUSHING**

1. Remove the 1/4" flexible hose from point „A" (diagram p. 16).
2. From 6m long 1/4" flexible hose (included) cut off a piece long enough to reach from the filter to the sink.
3. Other end of the hose connect to point „A".
4. Open the ball valve at the water feed.
5. Slowly open the cold water valve. After the pressure increases, check for any leakage.
6. Flush prefilters for at least 5 minutes.
7. After prefilters flushing, close cold water valve and proceed to postfilters flushing.

### **7.5.2 RINSING END CARTRIDGES**

1. Disconnect the tubing/hose in the place marked on the diagram as "C" (PAGE 17).
2. Connect the tubing/hose with one end in the sink and the other in "A"- input from input "A" to "C".
3. Disconnect the hose in the place marked as "B" in the diagram.
4. Cut off specific length from the 6-meter ¼ tubing/hose included in the set – accurate length so you are able to connect the places marked in the diagram as "A" and "B".
5. Use the cut tubing/hose to connect the connectors marked in points "A and "B".
6. Slowly open the main cold water supply valve. After increasing the pressure in - check for leaks.
7. Rinse the cartridges for 5 minutes.
8. After flushing the cartridges, close the main cold water supply valve.

Connect the filter according to the diagram on page 17 and open the ball valve of the tank.

### **7.5.3 PRESSURE CONTROL CHECK**

1. Check all lines for obstructions to flow.
2. Open screed valve for continuous flow.
3. Open valve container.
4. Slowly open the main cold water supply valve. After pressurizing the system, check for leaks.
5. Close the spout valve. At this point, the filtered water will start flowing into the tank.  
**THE FIRST TWO FULL TANKS MUST BE DRAINED BEFORE THE WATER IS SHELF LIFE AND IS GOOD FOR USE.**
6. Leave the tank to fill for 2 hours. Then open the spout valve and leave it until the tank is completely empty.
7. Close the spout valve and leave the tank for another 2 hours until it is on completely filled. Drain the tank again. Only after twice emptying the tank, drinking water can be used.  
**ATTENTION:** In the first week after installation of the system, the filter should be checked for leaks every day.

## 8.1 REPLACEMENT OF PRE-TREATMENT CARTRIDGES

Follow the below guidelines to replace the initial purification cartridges (4, 1, 2 purification stages):



**NOTE:** THE USE OF CARTRIDGES AND MEMBRANES OTHER THAN THOSE RECOMMENDED BY THE MANUFACTURER MAY CAUSE EXTENSIVE DESTRUCTION OF THE SYSTEM AND LIMIT THE LIABILITY OF THE GUARANTEE.

1. Shut off the water supply to the system by closing a ball valve on the water connection.
2. Close the ball valve of the tank by screwing perpendicular knob to the valve body.
3. Open the discharge valve to equalize the pressure.
4. Leave the system for 1 minute to completely reduce the pressure.
5. Using a master wrench unscrew the fittings at the ends of initial cartridges, then throw away the cartridges.
6. Wrap the threaded end of each connector with the Teflon tape, and then screw connectors to the new initial cartridges using a master wrench.
7. Reconnect the hoses to the connectors located at the ends of the final cartridges.

**NOTE:** The need for shorter periods between the cartridges replacements depends on the quality of the supplying water. Check periodically the cartridges and make the maintenance records, which will allow to arrange the maintenances program, depending on individual conditions and water quality.

## 8.2 MEMBRANE INSTALLATION/REPLACEMENT

Follow the below guidelines to replace the membrane (hase 3 of treatment):

1. Shut off the water supply to the system by closing a ball valve on the water connection.
2. Close the ball valve of the tank by screwing perpendicular knob to the valve body.
3. Open the discharge valve to reduce the pressure in the system.
4. Leave the system for 1 minute to completely reduce the pressure.
5. Disconnect the grey 1/4" hose from the head of the membrane casing by following the instructions described on page 8 of these instructions (see: Disconnecting from the standard JG type quick connector).
6. Unscrew the membrane casing head by turning it to the left Make sure the O-rings remain in place in the recesses of the casing neck.
7. Carefully grab the plastic end of the inner membrane tube with the help of forceps, and pull it out. This operation may require a slight twisting motion to the left and to the right, because the membrane is tightly fitted to the casing.

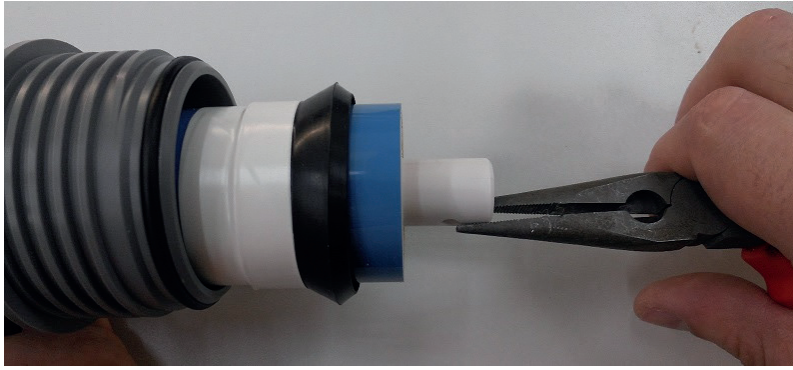

PRIOR TO THE MEMBRANE INSTALLATION, CUT THE TRANSPARENT FILM FROM THE TUBE SIDE WITH TWO O-RINGS, LUBRICATE O-RINGS WITH VASELINE AND INSERT INTO THE CASING THROUGH THE PROTECTIVE FILM, NOT TO TOUCH THE MEMBRANE WITH YOUR FINGERS (**DO NOT REMOVE THE BLUE FILM OF THE MEMBRANE - IT IS THE MEMBRANE ELEMENT**).

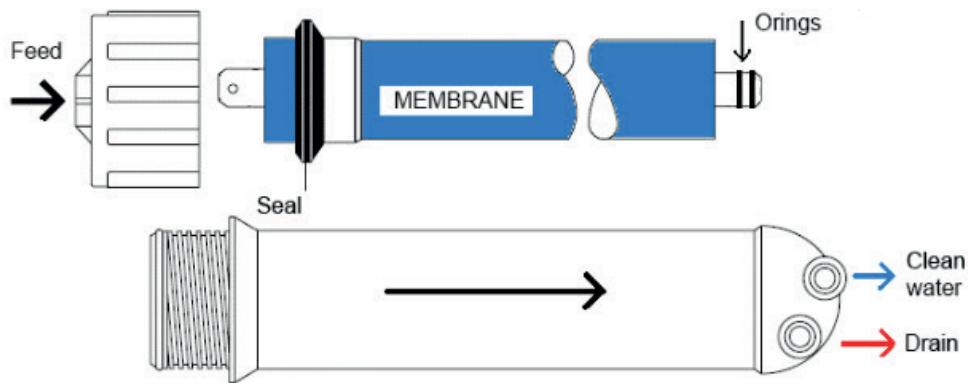

**INSERT THE NEW MEMBRANE INTO THE CASING, ALWAYS IN THIS DIRECTION!**

8. Grease with jelly petroleum the O-ring seals on the membrane core. Insert a new membrane into the casing in the direction shown in the figure above, while pressing the protective foil with thumbs. Push the membrane, until the O-Ring seals reach the membrane casing slot until it stops. Screw the membrane casing head by turning it to the right. Connect the 1/4" hose from the head of the membrane casing by following the instructions described on page 8 of these instructions (see: Connecting to a standard JG type quick connector).

### 8.3 FINAL CARTRIDGES REPLACEMENT

Follow the below guidelines to replace the final cartridges (4, 5, 6 purification stage) :

1. Shut off the water supply to the system by closing a ball valve on the water connection.
2. Close the ball valve of the tank by screwing perpendicular knob to the valve body.
3. Open the discharge valve to equalize the pressure.
4. Leave the system for 1 minute to completely reduce the pressure.
5. Reconnect the hoses to the connectors located at the ends of the final cartridges.
6. Then follow the instructions in 7.5.2 Rinsing the final cartridges.

### 9. MAINTAINING THE SYSTEM AND PROCEEDING IN CASE OF FAILURE

1. Replacement of initial cartridges (1 - 2 purification stages) every 3-6 months.
2. Replacement of final cartridges (4 - 6 purification stages) every 3-6 months.
3. Membrane replacement (3 purification stage) every 2-5 years.

PERFORM THE FOLLOWING STEPS, IF ANY OF THE BELOW SITUATIONS OCCURS WITHIN SIX MONTHS OF THE SYSTEM INSTALLATION:

1. THE SYSTEM GENERATES LITTLE WATER: Replace initial cartridges. If the performance does not improve, replace the final cartridge (stage 4 and 5) and the membrane.
2. Regularly (e.g. once a month) check the level of TDS(\*) of the water supplied to the system, as well as the purified water. That data allows to track the system performance and the water treatment efficiency. The osmotic membrane should reduce TDS of the supplying water by at least 90%. If TDS parameter of the treated water does not fit within certain limits, replace the initial and final cartridges and the osmotic membrane.

#### Caution!

To make the device work properly and maintain an optimal value of TDS, a 1 liter water intake of the system should be used. In the case of collection of smaller or larger amounts of water, differences in the physical and chemical parameters of the water may occur. The next 1 liter of water intake should occur after 6 hours. This is the period of time necessary to recover the deposit, after which the water shall recover the appropriate level of mineralization.

TDS value is determined by the saltiness of the supplying water and the amount of water flown through the system. Initially, the obtained TDS is increased, but after more intakes from the system it is stabilized. During the use, the deposit is gradually depleted, therefore it is important to make replacement of cartridges in the appropriate period. (\*) TDS – Total Dissolved Solids - the total content of substances dissolved in water expressed in ppm (part per million = mg / l)

Water that flown through the filter may contain gas bubbles which is a normal phenomenon.

PROBLEM	CAUSE	SOLUTION
<b>TASTE AND/OR ODOR OF CHLORINE IN TREATED WATER</b>	<ul style="list-style-type: none"> <li>• The concentration of chlorine in the supplying water exceeds the allowable limit and led to the membrane damage.</li> <li>• The initial cartridge stopped removing chlorine from the water supply.</li> </ul>	
<b>OTHER TASTES AND ODOURS</b>	<ul style="list-style-type: none"> <li>• Final cartridge wear.</li> <li>• Membrane wear</li> </ul>	<ul style="list-style-type: none"> <li>• Replace the final cartridge. If the taste and odour persist, replace the initial cartridges and the flow restrictor.</li> <li>• Perform disinfection.</li> </ul>
<b>THE SYSTEM GENERATES LITTLE WATER</b>	<ul style="list-style-type: none"> <li>• Initial cartridges or membrane clogged with sedimentation sludge.</li> <li>• Water supplying the system does not meet the required conditions.</li> </ul>	<ul style="list-style-type: none"> <li>• Replace initial cartridges. If the speed of treatment does not improve, replace initial cartridges, final cartridges, membrane and flow restrictor.</li> <li>• Increase water pressure (depending on needs) to meet the conditions, prior to the system maintenance.</li> </ul>
<b>THE SYSTEM PURIFIES WATER SLOWER THAN USUALLY</b>	<ul style="list-style-type: none"> <li>• The air pressure in the tank is under 5-7 psi.</li> </ul>	<ul style="list-style-type: none"> <li>• Open the spout valve and drain the tank to the end. Check the pressure in the tank, leaving the spout open. If it is low, equalize the pressure to 0.4 bar (6 psi). Close the spout for refilling the tank.</li> </ul>
<b>TREATED WATER HIGH TDS</b>	<ul style="list-style-type: none"> <li>• Water supplying the system does not meet the required conditions.</li> <li>• Membrane wear.</li> </ul>	<ul style="list-style-type: none"> <li>• Increase water pressure (depending on needs), maintenance treat water etc. additionally to meet the conditions, prior to the system.</li> <li>• Replace initial cartridges, final cartridges, membrane and flow restrictor.</li> </ul>



<p><b>TANK IS NOT FILLING UP</b></p>	<ul style="list-style-type: none"> <li>• Air pressure in the tank is higher than 5 -7 psi.</li> </ul>	<ul style="list-style-type: none"> <li>• Unplug the tank from the system (close main water feed valve, open the faucet to remove the pressure from filtering system, remove the hose from tank ball valve). Check the pressure in the tank. If it is higher than 7 psi, lower it to 0,4 bar (6 psi). Plug the tank to the system. Close the faucet. Open the main water feed valve</li> </ul>
<p><b>CONSTANT WATER FLOW TO THE DRAIN AFTER FILLING UP THE TANK</b></p>		<ul style="list-style-type: none"> <li>• The shut-off valve is clogged.</li> <li>• Clean or replace if required.</li> </ul>

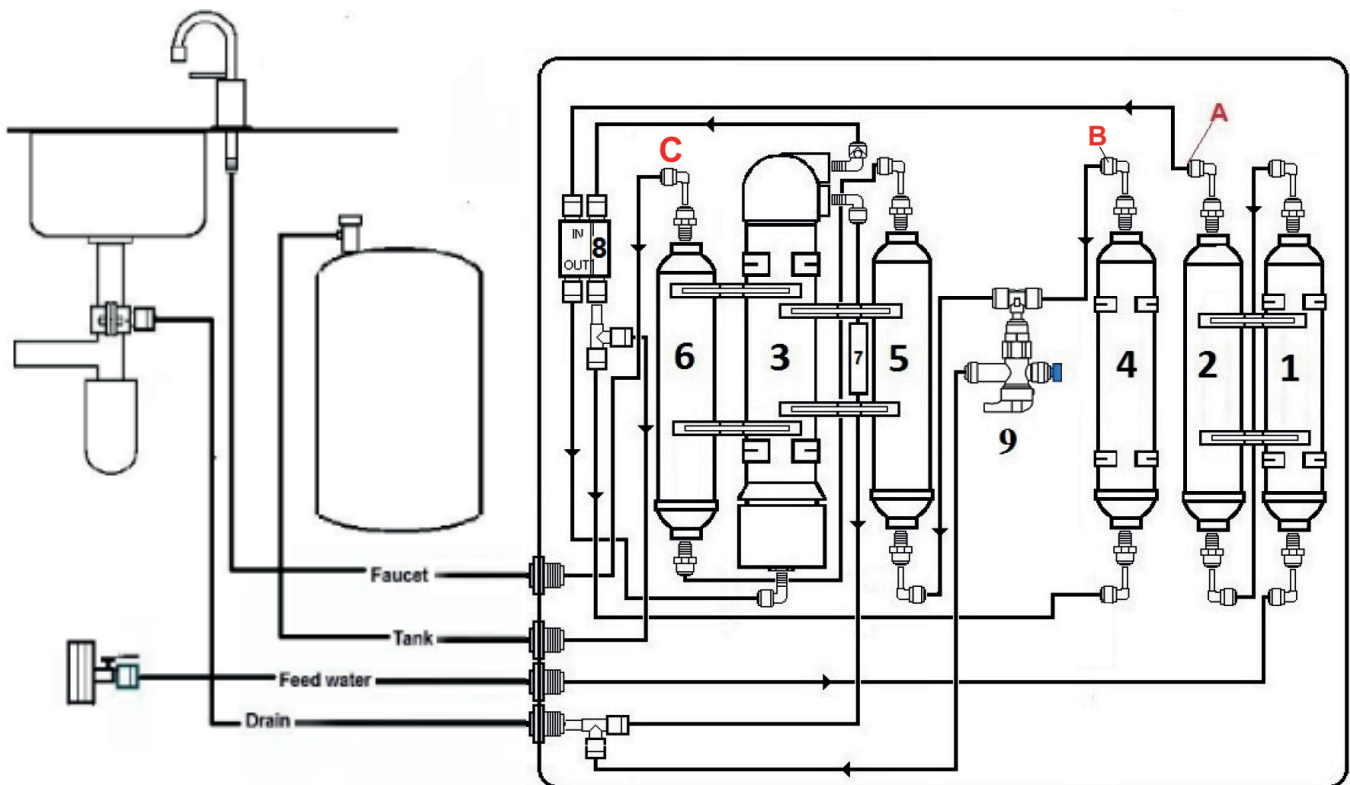

1. AC-IL-PP INITIAL MECHANICAL CARTRIDGE
2. AC-IL-PP-GAC INITIAL MECHANICAL CARTRIDGE WITH ACTIVE CARBON
3. AC-OM-75 MOLECULAR MEMBRANE
4. AC-IL-GAC FINAL CARTRIDGE WITH ACTIVE CARBON
5. FINAL CARTRIDGE – STRUCTURE + H2 + ORP + pH AC-IL-STR-H2-ORP-PH
6. AC-IL-MIN FINAL MINERALIZING CARTRIDGE
7. FLOW RESTRICTOR
8. SHUT-OFF VALVE
9. VENTING VALVE

Put the water tank close to the filters, when installing the filter system. The radius of the effective range of the field from MIM-2 to approx. 35 cm. MIM-2 pulser should be attached in such a way that **the arrow on the back casing is facing the tank upper part** (inscriptions on a sticker on the front side are visible „upside down”). The pulser can be easily rotated, because it is attached to the tank by means of Velcro.



**GOOD**



**BAD**

**Turn on the pulser with the range „2” set up.**

The pulses should be located on the tank, preferably in parallel position towards the filters assembly (in the middle). Such MIM-2 location will ensure the effective magnetic field impact, not only on the water in the tank, but also on the filters assembly and the filter deposits themselves (MIM-2 optimal use). The pulsed magnetic field from MIM-2 arranges the structure of water (it will affect the ordering of the water dipoles, which shall prevent crystallization and aggregation of minerals), shall provide water with information in the form of the magnetic field frequency with the parameter of slowly changing magnetic field of the ground (scope 2), broke high molecular chains of water and restore hexagonal structure to water. Those parameters were lost by water due to processing (suction pressure and discharge).

It is possible to use the pulser to the individual application in case of discomfort - just detach MIM-2 pulser from the tank and put the side marked by the arrow on the point where the discomfort is felt.

The relaxing operation of the magnetic field including MIM-2 shall effectively remove the problem (range „1” recommended use).

The installed tap is sufficient for a period of approx. 1 month (at continuous operation). Absolute indication of the use of zinc-carbon batteries 6F22 9V.

THE SYSTEM USER SHOULD ENSURE THAT THE PERSON EXECUTING THE INSTALLATION AND ANSEMBLY OF THE MOLECULAR WATER PURIFICATION AND TREATMENT SYSTEM FILLS IN THE APPROPRIATE FIELDS OF THE TABLE FOR THE POSSIBLE MAINTENANCE WORKS EXECUTION.

<b>INSTALLATION AND STARTUP EXECUTED BY:</b>	
<b>PIPING SYSTEMS</b>  Date of execution: .....  Last name: .....	Company: ..... ..... ..... .....  Tel.: ..... .....
<b>INSTALLATIONS AND ELECTRICAL CONNECTIONS</b>  Date of execution: .....  Last name: .....	Company: ..... ..... ..... .....  License No.: .....  Tel: .....

## SERVICE

### AMII SP. Z O.O.

tel. 42 6484848 wew 102  
serwis@amii.pl

(woj. zachodniopomorskie, lubuskie, dolnośląskie, opolskie, wielkopolskie, łódzkie, świętokrzyskie, śląskie, małopolskie, podkarpackie)

tel. 22 8864010  
warszawa@amii.pl

(woj. pomorskie, kujawsko-pomorskie, warmińsko-mazurskie, podlaskie, mazowieckie, lubelskie).

### EGIDA CONSULTING SP. Z O.O. SP.J.

office@visantous.com  
O: (813) 235-0308 F: (866) 431-0676

1. The guarantee is granted for a period of 24 months from the date of sale.
2. Any defects found in this period will be repaired free of charge at the due time from the date of delivery to the guarantor, in accordance with the Law of 30.05.2014 On special conditions of consumer sales and amendments to the Civil Code. In case of no defects found, the device shall be available for the owner in the place where no defects were found.
3. In case of the complaint notification in the absence of defects or non-compliance with the agreement, the device shall be considered to be notified for the paid guarantee reviewing. The cost of the review is consistent with the current price list.
4. The duties of the device holder include:
  - appropriate and in accordance with the operating instructions
  - carrying out every 6 months a paid replacement of filter cartridges and the equipment sanitizing under the threat of loss of guarantee.
5. The Guarantee does not cover:
  - parts and filter cartridges, that are subject to ongoing wear (in accordance with par. 4 of the guarantee conditions)
  - Mechanical damage to the device and defects caused thereby
  - damages and faults caused by the improper use, inconsistent with the instructions
  - damage and defects caused as a result of modifications and design changes.
6. The basis for the guarantee rights implementation is a guarantee card and/or proof of purchase (receipt or invoice), including a readable device name, date of sale and the seller's contact details.
7. In case of lack of the guarantee card and/or proof of purchase, the device will be repaired for a fee.
8. The notifications will be accepted under the telephone number 42 648 48 48 ext. 102, or email [serwis@amii.pl](mailto:serwis@amii.pl), or address amendments Sp. o.o., ul. Grabińska 23, 92-780-Łódź .
9. COD will not be accepted by the guarantor.