

# cricket® owner's manual

**2021**



# OUT IS IN™

# HEADS UP!

- 1** Tent Side: Please read chapter SITE SELECTION AND SETUP for instructions on raising, lowering and properly stowing your tent side to avoid **damage** when lowering roof.
- 2** Plumbing: Please read chapter PLUMBING SYSTEM for instructions in filling and draining the tanks and lines of the Cricket. Check chapter TROUBLESHOOTING for common mishaps.
- 3** Hot Water Heater: Fill your hot water heater by running water in sink set to 'HOT'. When water stops sputtering and runs constantly tank is full.
- 4** Wheel Lugs: On your first trip tighten wheel lugs at start and at 10, 25, and 50 miles. Thereafter, check wheel lugs before each trip, after excessive breaking and following winter. Always tighten to the manufacturer's specification of 90 ft. lbs.
- 5** Before driving, make a habit of locking and dead bolting all doors and securing all window latches.
- 6** Keep an eye out – make a habit of walking around your habitat before you set out, when filling up at a service station, when hitching up at the campground. Preventative maintenance is always the best.
- 7** If you are driving down a dirt road please go slow, be careful, never wonder if you are about to bottom out! Get out and take a look! Make someone 'spot' you. Remember - bumps are bumpier for your habitat.
- 8** **If you got an Overland model then remember that you are four inches taller than usual, are likely to challenge more challenging roads and more likely to be further down the road than others! Great! That also means you should diligent and careful and consider any or all risks in a considered fashion.**
- 9** Have fun!



## WELCOME TO the 2021 CRICKET!

Congratulations on your new Cricket®, or Overland Cricket!

We hope you go somewhere we have never been. Then we hope you share it with us and our (your) community.

We hope you stay safe and sane and make the best of every new adventure. These days are strange and hard but the outdoors always beckons and always refreshes.

The '21 Cricket has a new modular storage system of spaces and crates that we hope you love. It is designed to keep all the normal things that everyone stows safe and in their place AND allow you to do the same with the odd or special items you and only you bring to the great outdoors. It is designed to let you live indoors and out as seamlessly as we can devise to date. We have a new orange tent that will revive a favorite view of mine – habitats glowing like gentle lanterns in the night – and the orange also harkens back to Taxa's original tent color. The same tent has a new front window where both the solid and screen can be unzipped giving you unfettered access to the front roof portion from the inside of your habitat. I suppose the same goes for chipmunks and marmots so be aware....

Buying a habitat is different than buying a vehicle – you don't just hitch up and go – plotting and planning and outfitting and optimizing is part of the fun. The Cricket is a product of course but it is even more an investment in your lifestyle. Your grow into it. We have a set of wonderful Habitat Specialists and an even more wonderful community that will help!

The Cricket is for anyone and everyone. We thought mostly of couples or a couple of friends, with a few kids or a few dogs in tow. We are agnostic – go alone, create a clown car environment. I can be a little more specific!. The Vberth can handle two adults (and an infant or sometimes a dog). Two more, generally kids as there is a weight limit and length limit, can sleep above hanging from the ceiling (like bats!) in berths. I know one Cricket out there has a dog up that sleeps above . We at Taxa are agnostic about who and what you camp with. We just love to help you get there.

An Overland edition Cricket is available too – it sports a 4" lift and a strong Timbren Axle-less suspension that gets you further down the (dirt) road than any other 15 footer. That lift though does have the effect of making it less and less likely a Overland Cricket squeezes into your garage. Measure!

Please support our nations' park systems. It takes work to keep things wild and we are an essential part of that work as users, as stewards, as advocates. Please take with you only what you need and leave nothing behind!

As ever:

*It is important that you thoroughly review this Owner's Manual. Please also consult it anytime you have a question regarding the safe use, operation and maintenance of your habitat, and its systems and components. Understanding how they work is an important part of having a fun, safe travel experience.*

We want your first and every adventure to be great. Have a practice session in your driveway. Hitch that habitat up and drive it around the block. Get comfortable. Ask questions! Get answers to any questions, issues or problems that arise during your practice. Get answers from the community, from our FAQs and specialists – send us an email . Give us a call or email us at **customerservice@taxaoutdoors.com**. Many questions can be answered quickly and easily and save you a lot of hassle.

Best,

Garrett Finney,  
TAXA Founder



## **YOUR OWNER'S MANUAL (AND OTHERS)**

Make this Owner's Manual a permanent part of your habitat, download it to a smart device you carry with you or print it out to keep it with the habitat at all times. Keep the manuals, stickers and tags associated with your habitat's items, add-ons, appliances and equipment in the habitat as well for easy reference. All manuals including components with pass thru warranties etc are available on our website on the MANUALS page - <https://taxaoutdoors.com/manuals/>

This manual is not intended to be inclusive of every operational aspect of your unit. It should be utilized and referenced by you in conjunction with the separate, additional manuals provided by the manufacturers of the different components, component parts, appliances, add-ons, systems, and accessories in your unit. Your unit will contain any such manuals provided to Taxa Inc. by the specific component part, appliance, add-on, system, and accessory manufacturer. Please read them to gain a more complete understanding of the operation and maintenance of the products and appliances installed in your habitat.

**READ THE ENTIRE MANUAL AND OBEY ALL CAUTION, WARNING, DANGER AND OTHER SAFETY-RELATED STATEMENTS PRIOR TO OPERATING YOUR HABITAT.**

### **please note**

**This Owner's Manual contains the most up-to-date product information available at the time of publication. However, due to continuous product development, innovation and improvements, Taxa Inc. reserves the right to make changes in production techniques/processes, product materials, product specifications and components. Such changes may be made without prior notice or any obligation upon Taxa Inc. to make corresponding changes or improvements in or upon its already manufactured, installed and/or sold habitats and/or products. Please visit our website at [www.taxaoutdoors.com](http://www.taxaoutdoors.com), <https://taxaoutdoors.com/manuals/> to check for manual updates and our current manual.**



**Table of Contents**

WELCOME TO the 2021 CRICKET! .....3

YOUR OWNER’S MANUAL (AND OTHERS).....4

SAFETY TERMS.....5

OVERVIEW OF SAFETY PRECAUTIONS .....6

HITCHING .....7

.LOADING..... 10

TOWING..... 12

BRAKES..... 15

TIRES ..... 16

CRICKET DESCRIPTION ..... 19

PLUMBING SYSTEM..... 26

ELECTRICAL SYSTEM ..... 34

BATTERY..... 40

PRE-TRAVEL CHECKLIST ..... 43

SITE SELECTION AND SET UP ..... 44

VENTILATION ..... 51

FOUR SEASON USE / EXTREME WEATHER..... 53

GENERAL CARE AND MAINTENANCE ..... 55

STORAGE, WINTERIZATION & BRINGING OUT OF STORAGE..... 57

TROUBLESHOOTING ..... 58

LIST OF AUTHORIZED DEALERS..... 61

your Cricket LIMITED WARRANTY ..... 62

**SAFETY TERMS**

We have included various safety messages in this manual, all of which are important. Please read and obey them. The following are safety-related terms and symbols referred to in this manual and their corresponding meanings/definitions:

DANGER indicates an imminently hazardous situation that, if not avoided, will result in death or serious injury.

WARNING indicates a potentially hazardous situation that, if not avoided, could result in death or serious injury.

CAUTION indicates a potentially hazardous situation that, if not avoided, may result in minor or moderate injury.

NOTICE is used to address practices not related to personal injury. This applies to hazardous situations involving property damage or important information regarding the maintenance of your vehicle.



## OVERVIEW OF SAFETY PRECAUTIONS

You'll find various safety-related references, discussions and instructions throughout this owner's manual, and all of them are important. This overview is not an exhaustive list of the safety issues discussed or contemplated in this manual. Please carefully read and follow all safety issues discussed in this manual. If you have any questions regarding habitat safety issues, please contact your dealer and/or Taxa Inc. - [customerservice@taxaoutdoors.com](mailto:customerservice@taxaoutdoors.com) takes you to all of us – general questions, service, warranty, sales)

The following is a broad snapshot of a few of the more common safety instructions/discussions/issues in the use and operation of your new habitat:

- Be sure load/cargo weight does not exceed your GVWR and that weight is distributed properly before travel. Please refer to the "Loading" section.
  - *fully close-up and lock your habitat before towing ...* to ensure efficient and safe transportation.
  - Be sure safety chains and breakaway switch have been properly attached and secured as part of your hitching up process.
  - Be sure to have a qualified technician conduct the maintenance, service and adjustments on your brakes periodically and as needed. Do NOT travel until all brake problems, if any, are fixed. See "Brakes" section.
  - Test your blinkers, brakes and lights before towing on a public road, confirming that they are working properly and in synchronization.
  - *do not allow passengers to ride in the habitat during travel ...* the transport of people puts their lives at risk and is illegal.
  - *tires ... be vigilant in your tire inspection and maintenance.* Properly maintained tires improve the steering, stopping, traction, and load-carrying capability of your habitat and tow vehicle. Under-inflated tires and over-loaded vehicles are major causes of tire failure. Please refer to "Tires" section for a more detailed discussion on your tires and tire safety.
  - Keep your habitat well-ventilated. Please refer to the "Ventilation" section for details.
  - Clean your potable water hose, and drain and clean holding tanks periodically and / or as needed.
  - Be sure all electrical uses and activities involve proper grounding.
- *reduce fishtailing & sway ...* excessive sway of your travel habitat can lead to the rollover of the habitat and tow vehicle resulting in serious injury or death. This usually due to incorrectly loading the habitat but can also indicate road conditions or habitat damage. You may choose to install a separately purchased sway control device to help reduce sway. Be sure to contact your dealer or Taxa Inc. if you have any questions regarding sway control device alternatives. Please also refer to the sway and fishtailing discussion in the "Towing" section.
- *generator safety ...* if you decide to use a generator, do not operate it inside the habitat or in any other enclosed space. Be sure to follow all instructions and warnings in the manual provided with the generator, if any.
  - *lug nut torque ...* be sure wheel mounting nuts (lug nuts) on habitat wheels are tight and properly torqued. Inadequate and/or improper wheel nut torque (tightness) is a major reason that lug nuts loosen. Loose lug nuts can rapidly lead to a wheel separation with potentially serious safety consequences. Refer to a qualified technician before travel if you have any questions regarding your wheel nut torque. See also "Tires" section.
  - *appliances and equipment ...* some Cricket equipment (cooktop, furnace, etc.) operate on propane. Propane is highly flammable and contained under high pressure. Improper use may result in a fire and/or explosion. Be sure to follow the instructions and warnings provided by the manufacturer of such appliances, if any.

## HITCHING

Our habitats require a 2" diameter hitch ball. ( Overland editions are outfitted with a Lock And Roll coupler). *Use of any other hitch ball diameter size will create an extremely dangerous condition that can result in separation of the coupler and ball, and/or hitch ball failure.* Other than this crucial 2" diameter requirement, there are numerous habitat hitches and hitching components available to you for your habitat. Be sure to consult your tow vehicle manufacturer for hitch and/or hitch assembly alternatives.

*pre-hitch/coupling/trip considerations and inspection* .... be sure your hitch and tow vehicle are rated for the Gross Vehicle Weight Rating (GVWR) of your habitat. Remember that the hitch load rating must be equal to or greater than the coupler load ( the hitch is attached to the car, the coupler to the habitat). Be sure the hitch size matches the coupler size.

Examine all hitch components before hitching, looking for wear, corrosion, deformations, stripping and cracks. Replace worn, corroded or cracked hitch components before coupling the habitat to the tow vehicle. Be sure the hitch components are tight and that the ball-locking device works freely before coupling the habitat to the tow vehicle. Remember to also inspect the safety chains. Be sure to correct any noted problems or defects before towing the habitat.

Important Note: be sure to raise all habitat jacks and close the habitat fully before driving off after hitching. One of the most common mistakes is to forget to raise a stabilizer jack and bending it..

Your habitat is equipped with a 7-pin connector, which synchronizes the lights of your tow vehicle and habitat. It can also connect their respective braking systems. Use of electric brakes are not required in every State, however, we strongly recommend that you use them.

**WARNING: THE PROPER SELECTION AND CONDITION OF THE COUPLER AND HITCH IS ESSENTIAL TO THE SAFE TOWING OF YOUR HABITAT. A LOSS OF COUPLING MAY RESULT IN DEATH OR SERIOUS INJURY.**

**WARNING: AN IMPROPERLY COUPLED HABITAT CAN RESULT IN DEATH OR SERIOUS INJURY.**

**WARNING: USE OF A TOW VEHICLE WITH A TOWING CAPACITY LESS THAN THE LOAD RATING OF THE HABITAT CAN RESULT IN LOSS OF CONTROL, AND MAY LEAD TO DEATH OR SERIOUS INJURY.**

Hitching up your habitat will get easier with practice. The hitching steps described below are typical. However, we highly recommend that you also consult the hitching and unhitching instructions associated with your particular tow vehicle and hitching configuration.

*hitching steps:*

- for 2" ball:



- for Lock and Roll (Overland):





- (1) crank the tongue of the habitat jack until the hitch coupler is raised enough to clear the tow vehicle;
- (2) back the tow vehicle to the habitat until the hitch ball or 'pin' is directly under the habitat coupler. The use of a backing aid mirror may be helpful, especially if you are hitching alone;
- (3) set the parking brake in the tow vehicle;
- (4) be sure the coupler latch-locking lever is fully open, and then lower the tongue jack until the ball is firmly seated in the socket;
- (5) close the coupler latch and secure it with a locking pin or bolt (*you can use the pin that locks the caster wheel on to the front jack, the Lock and Roll comes with a propriety pin*); If you cannot get the latch to go down try pulling the tow vehicle forward, or reversing a tiny amount to create clearance or release pressure (this occurs usually when the habitat or tow vehicle is on a small slope or soft ground).
- (6) securely attach the safety chains in a crossing pattern to the tow vehicle and confirm that they are properly connected to the habitat. Do not fasten chains to any part of the hitch unless the hitch has holes or loops designed specifically for that purpose, be sure the chains do not drag during towing;

**WARNING: IMPROPER RIGGING OF THE SAFETY CHAINS CAN RESULT IN LOSS OF CONTROL OF THE HABITAT AND TOW VEHICLE, LEADING TO DEATH OR SERIOUS INJURY, IF THE HABITAT UNCOUPLES FROM THE TOW VEHICLE.**

- (7) Connect the breakaway switch. Attach and secure the breakaway switch cable to the tow vehicle bumper or frame independently of the safety chains. The following are guidelines for attaching the cable:

The cable should come straight out from the switch to attach to the tow vehicle  
 The switch and cable should be located and secured on the same side of the habitat and tow vehicle  
 Do not loop the cable over the hitch ball; the cable may bounce off while the vehicle is moving  
 Before towing you may test the breakaway assembly by pulling the pin out of the switch to confirm activation of the habitat electric brakes. See also the diagram/depiction in "Towing" section.

**WARNING: DO NOT CONNECT THE BREAKAWAY SWITCH LANYARD TO THE HITCH BALL OR ANY PART OF THE HITCH ASSEMBLY.**

Note: your breakaway switch will automatically engage the electric habitat brakes if the safety chains fail during uncoupling.

- (8) connect the power cord between the tow vehicle and the habitat, leaving enough slack for the tow vehicle to turn without disconnecting the power cord;

coupler securely latched and pinned





SHOWN: 2" ball coupler

habitat wiring plugged securely into tow vehicle, lights tested

chains crossed and securely attached to frame of hitch

breakaway switch cable attached to tow vehicle separate from chains

(9) adjust side mirrors;

(10) check all lights on habitat and tow vehicle, ensuring that they are working properly.

(11) confirm the brakes are working properly prior to towing the habitat on a public road. You can, for example, check the operation of the habitat brakes by pulling forward and using the hand control of any proportional brake controller.

(12) You may, depending on your tow vehicle or intended usage of the habitat, want to consider the use of a weight distributing hitch and or sway bars. These distribute the tongue weight of the habitat further away from the rear and can help in vehicle handling.



(example of weight distributing hitch assembly)

**FOLLOW ALL INSTRUCTIONS PROVIDED BY YOUR TOW VEHICLE'S TOW PACKAGE MANUFACTURER AND/OR INSTALLER**



## .LOADING

The process of safely and properly loading your habitat should become easier with practice and experience. Please first get familiar with and understand the following terms related to your habitat's weight, carrying capacity, and rating:

*gross vehicle weight rating (GVWR)* is the maximum permissible weight of the habitat when fully loaded and equipped/outfitted. It includes but is not limited to all weight at the habitat axle(s) and tongue or pin as well as all add-ons, appliances, accessories, potable water, etc. Your habitat's GVWR is 2700 lbs for the regular Cricket, 3000 for the Overland Cricket lbs. This number is recorded on the permanent label on the tongue your habitat.

*Dry weight or unloaded vehicle weight (UVW)* is the weight of the habitat as manufactured at the factory (typical weight without loading, no options). It includes all weight at the habitat axle(s) and tongue or pin. Your habitat's standard UVW is approximately 1753 lbs for the regular Cricket, 1978 lbs for the Overland Cricket. However, you will need to account for the weight of dealer or third-party installed add-ons, options and accessories, if any, in determining your actual UVW. In sum, your actual UVW will vary (and increase) to the extent you have outfitted your habitat with additional items. Note: Your cargo carrying capacity (discussed below) will vary (and decrease) to the extent of the weight of dealer or third-party installed add-ons, options and accessories, if any.

*cargo carrying capacity (CCC)* is equal to GVWR minus UVW and potable water weight. Your habitat's CCC is approximately 900 lbs for the regular Cricket, 1022 lbs for the Overland Cricket. However, remember that your actual CCC will vary (and decrease) to the extent you have outfitted your habitat with additional items. Please refer to the stickers located at the front exterior of your habitat for CCC.

*gross axle weight rating (GAWR)* is the value specified as the load carrying capacity of a single axle system, as measured at the tire-ground interfaces. Your habitat's GAWR is 3500 lbs for the regular Cricket, and 3500 lbs as well for the Overland Cricket. Please refer to the sticker located at the front exterior of your habitat for GAWR.

*gross trailer (habitat) weight (GTW)* is the weight of the habitat with all the items and supplies that are loaded into the unit at any point in time and must be less than the allowed GVWR.

## WEIGHT GENERALLY

Before towing, you must choose the items you will load onto your habitat and then determine whether the loaded weight is safe and proper. Of course, the best way (highly recommended) to calculate the loaded weight of your habitat is to have it weighed while loaded, and then compare it with the GVWR. Otherwise, you will need to do some calculations on your own in order to make an appropriate determination. If the loaded weight of your habitat exceeds the GVWR, your habitat is overloaded and should not be towed. You will need to remove items from, and reduce the loaded weight of, the habitat until it's at or below the GVWR before towing. Note: remember to include in your calculations the weight of dealer or third-party installed equipment, options, add-ons, accessories and any other non-standard items. *As an additional safety precaution, we recommend that you take a conservative approach when doing your own weight calculations.*

## WEIGHT/LOAD DISTRIBUTION AND TONGUE WEIGHT

Proper weight and load distribution is essential to safe towing. Load the habitat evenly (front to back and side to side) and securely, keeping heavier items as low as possible. Be sure to secure the load. A firmly secured load will be less prone to shifting and should help maintain load balance during travel.

Tongue (the habitat arm extension that couples with the tow vehicle receiver) weight is the amount of weight borne by the habitat hitch and another important consideration when loading your habitat. Generally, the actual tongue weight should equal approximately 10-15% of the gross habitat weight. Excessive tongue weight will make your tow vehicle's steering and braking less responsive. Insufficient tongue weight may cause your habitat to sway.

You could weigh your loaded habitat's tongue to determine the actual tongue weight. However, you may also observe the actual tongue weight and determine if it is too light or too heavy. For example, a habitat with a proper tongue weight will form a straight line from front to back between the tow vehicle and the habitat. A habitat with the weight improperly distributed (i.e. a light tongue weight) will cause the coupling between the tow vehicle and habitat to rise, with the weight pressing down at the rear of the habitat and the front of the tow vehicle. Excessive tongue weight will do just the opposite.

If you notice a rise or fall in your tow coupling, you will need to redistribute the weight of the load before getting on the road. If you have trouble estimating the combined weight of your habitat plus cargo, take your loaded habitat to a vehicle scale at a nearby weigh station or truck stop. *Important Note: you need to also refer to your tow vehicle's towing capacity and other towing and load*

capacity-related definitions and instructions before getting on the road. Please also consult your supplying dealer or Taxa Inc. if you have any questions regarding these terms and/or loading your habitat.

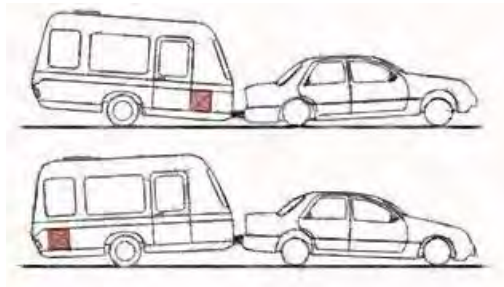

**example of poor weight distribution**



**proper ~10 to 15% of habitat on car coupler  
and or introduction of 'weight distributing' hitch system**

## TOWING

We want your towing experiences and practices to be safe and enjoyable. Please take your time, avoid being in a rush and give special attention to all safety matters prior to and during the towing of your habitat.

As previously indicated, we recommend that you practice towing your Cricket in, for example, an empty parking lot before going on your first camping trip. This initial trial and practice is fun and will help you get accustomed to and familiar with Cricket®'s systems and operation. Please also make note of any questions, issues or problems that arise during your pre-travel towing practice, and then inquire with your dealer or email us [hello@taxaoutdoors.com](mailto:hello@taxaoutdoors.com). You can also visit our website ([www.taxaoutdoors.com](http://www.taxaoutdoors.com)) for current contact information. Please also refer to the "Overview of Safety Precautions" and "Pre-Travel Checklist" sections before towing your habitat.

*safety chains ...* We have equipped your habitat with safety chains. Make use of them. Safety chains serve to maintain the connection between your habitat and the tow vehicle in the event of separation of the ball and habitat coupling. Be sure to hook the safety chains to the frame of the tow vehicle (not the hitch), crossing them under the habitat's tongue. Also, remember to inspect the length of the chains once they are attached to the tow vehicle frame. A proper chain length will allow turns and prevent the chains from dragging on the road.

*breakaway switch ...* Your habitat is equipped with a breakaway switch. For every Cricket the breakaway switch is wired to the Cricket's internal battery. Breakaway switches are designed to activate the electric brakes in the event your habitat disconnects/uncouples from the tow vehicle. Your habitat battery powers this braking. Ideally, the safety chains will prevent your habitat from disconnecting if the coupler comes off the hitch ball. However, if the safety chains fail, the breakaway pulls the pin out of the switch which fires the brakes and serves as a last line of defense against a runaway habitat. The breakaway switch cable needs to be secured to the tow vehicle bumper or frame independently of the habitat safety chains. The following are guidelines for attaching the cable:

- The cable should come straight out from the switch to attach to the tow vehicle
- The switch and cable should be located and secured on the same side of the habitat and tow vehicle
- Do not loop the cable over the hitch ball; the cable may bounce off while the vehicle is moving
- Before towing you may test the breakaway assembly by pulling the pin out of the switch to confirm activation of the habitat electric brakes. *See below*



switch location

cable attached independently to tow vehicle, with pin secured in switch

*tire pressure ...* you are responsible for maintaining proper tire pressure in the tires of your habitat and tow vehicle. Thus, always check your tire pressure and refer to the "Tires" discussion herein before traveling.

*brakes ...* you are responsible for inspecting and maintaining both your habitat and tow vehicle brakes before towing. Do not tow your habitat unless you have confirmed your brakes are in good condition and operating properly. Be sure to have a qualified technician perform all brake adjustments, service and maintenance. Please also refer to the "Brakes" discussion herein before traveling.

*lights ...* be sure to check all electrical connections to ensure all lights on the tow vehicle and habitat are functioning properly before traveling. The brake lights, and hazard and turn signals should be in synchronization with the tow vehicle.

*stay level ...* the habitat and tow vehicle must be level when hitched. Dragging may occur if the hitch is too low. Conversely, if the hitch is too high, the rear of the habitat is exposed to striking higher points in the road.

*general towing/driving ...* drive defensively, anticipating stops, braking early, and never following closely. We recommend maintaining a length of at least three cars and a habitat (approximately 65 ft.) between you and the car in front of you for every 10 mph of speed you are traveling (for example, at 60mph, you should maintain approximately 390 ft. of distance between your vehicle and the vehicle in front of you). This should give you adequate time to safely complete a proper avoidance maneuver (i.e. come to a safe stop, change lanes, etc.) in

the event of, for example, an abrupt stop or emergency.

Longer stopping distances are required when towing a habitat so remember to start braking sooner than you would if driving without your habitat. Begin slowing down well in advance of anticipated street/road dips and depressions. It also takes longer to accelerate when towing a habitat. Thus, remember to account for both the slower acceleration rate and the combined length of your tow vehicle and habitat when passing another vehicle and then safely returning to your lane. In sum, always pass, allow others to pass, and change lanes with care. We also do not recommend using cruise control or overdrive when towing/travelling.

**SWAY AND FISHTAILING** ... excessive sway or fishtailing of your habitat can lead to the rollover of the habitat and tow vehicle, and thus, serious injury or death. The tendency for the vehicle to sway increases with speed. Thus, reduce speed as needed and in inclement or harsh weather conditions (i.e. high winds, rainstorms, slippery roads, etc.). The following are a few tips for reducing sway or fishtailing if and when they occur and are not exhaustive: (1) *slow down gradually* .... do not jam/slam on the brakes or press on the accelerator, both of which may make the situation worse and result in severe injury or death. Instead, remove your foot from the accelerator and reduce your speed gradually whenever possible; (2) *minimize and avoid quick steering movements* .... Quick steering movements will actually cause increased sway and loss of control;

Keep both hands on the wheel, and hold the wheel as straight as possible until stability is regained; and

*As soon as practicable after regaining control* ... pull over and check tire pressures and cargo weight distribution, and inspect the habitat and tow vehicle for any signs of failure or defect. If you suspect a mechanical failure, recommend that you not tow until the problem is identified and remedied. If you choose to travel, do so at reduced speeds and with heightened caution until the problem can be identified and remedied.

**WARNING:** Side to side motion (sway) that begins as you reach a certain speed will likely become whipping at higher speeds. As soon as you notice sway, slow your vehicle by letting off the gas pedal. Then stop to check the habitat and tow vehicle as soon as it is safe to do so.

#### **OTHER IMPORTANT TOWING SCENARIOS**

*winding, narrow roads* ... stay in the center of the lane. This reduces the likelihood of the tires/wheels dropping onto the shoulder, another potential cause of hazardous sway. Do not cross the center-line unless safely changing lanes.

**WARNING:** If a wheel goes off the paved roadway, do not steer sharply and do not brake. Let off the gas pedal, slow down below 25 mph and then steer gradually back onto the roadway. Proceed with caution entering traffic.

*sharp turns* .... minimize the suddenness of sharp turns by anticipating them, slowing down well in advance of them, and taking them at low, substantially reduced speeds.

*steep, long grades* ... like sharp turns, be sure to anticipate steep grades. Down-shift into a lower gear or range in advance to assist your braking on a descent and to add power on a climb.

Note: avoid situations that require excessive and prolonged use of the brakes. If unavoidable, apply and release brakes at short intervals to give them a chance to cool. Downshift your tow vehicle to reduce braking needs on long down grades of highway.

*slippery, icy pavement* ... reduce speed and drive slowly. Remember that skidding/hydroplaning can occur with minimal moisture on the road. If skidding occurs, remove your foot from the accelerator and then gently apply the habitat brakes only.

*freeways and highways* ... try to pick and stay in the far right hand slow(er) lane.

*corner turns* ... habitat wheels do not follow the path of your tow vehicle's wheels during corner turns. The habitat will make a closer, tighter turn than the tow vehicle. Compensate by moving further into the intersection before turning so that the habitat clears any objects in or near the road such as but not limited to the curb and parked vehicles. Left turns require a wider than normal turn to help prevent the habitat from edging into an opposing lane. Use turn signals early for the traffic behind you and begin slowing down well in advance of your turn.

*mud and sand* ... when going through mud or sand, accelerate gently, if at all, and try to remain in the path of the previous vehicles. Let the momentum of the tow vehicle and habitat carry you through the problem area. If stuck, the habitat and tow vehicle should be towed out



while hitched.

*dirt, gravel, washboard roads ...* go slow, use caution, your habitat will move and vibrate more than the tow vehicle, a good rule of thumb is 25 mph or less, MUCH less on severely rutted roads.

*parking ...* Whenever possible, avoid parking on a grade. If unavoidable, turn the front wheels of your tow vehicle into the curb and set the parking brake. For added safety, place wheel chocks under the habitat wheels.

*additional towing safety information ...* can be found on the National Highway Traffic Safety Administration's web site: <http://www.nhtsa.dot.gov/Cars/problems/Equipment/towing/Towing.pdf>



## BRAKES

*overview ...* your Cricket is equipped with electric brakes and a wireless proportional brake controller. *Under normal driving/towing conditions, the habitat brakes will operate only in conjunction with a properly installed brake controller (which is also discussed below).* Please also obtain and read the separate manual of the brake controller.

**Important Note:** in an emergency uncoupling of your tow vehicle and habitat, your habitat electric brakes will automatically engage even without a brake controller. This assumes, of course, that you have properly attached and secured the provided breakaway switch. *See also "Hitching" and "Towing" sections herein.*

*brake controller, breaking-in your brakes and synchronization ...*we recommend that you break-in your habitat brakes in, for example, an empty, paved parking lot, not on a public road, when practicable. To break-in your brakes, apply the brakes at least twenty (20) times, decreasing your speed approximately 20 mph in each application. Allow a few minutes for the brakes to cool between each application so that the brake shoes and magnets "wear-in" to the drum surfaces.

When a brake control or controller is properly installed, your habitat electric brakes will work in synchronization with your tow vehicle brakes. If you sense lock-up, "grabiness," or your habitat "jerking" or "pushing" the tow vehicle when braking, your braking systems are not properly synchronized. You may need to have small adjustments made periodically because of, for example, changing loads and driving conditions. Brake Controllers are proportionally adjustable and small adjustments are easily made. Brake Controllers are proportionally adjustable and small adjustments are easily made. *Important Note: be sure to refer to and follow your brake controller manual for instructions on synchronization, use, maintenance and adjustments.*

**CAUTION:** Minimum vehicle stopping distances are achieved when wheels approach lock up. Brake lock up should be avoided as it results in poor vehicle stability and control.

*connector ...* your provided 7-pin cord connector located at the front of the habitat transfers electrical power from the tow vehicle battery to the habitat brakes, lighting system, and battery.

*braking tip ...* do NOT use the habitat brakes only. They were designed to provide braking for your habitat, not the tow vehicle. As previously indicated, habitat brakes are not required in every State. Thus, some States may allow you to solely use your tow vehicle's brakes when towing your habitat. However, remember that the added weight of both the habitat itself and the cargo you are carrying puts additional load pressures on your tow vehicle brakes. It also may, under some conditions (i.e. slippery pavement, loose gravel, etc.), impact overall stability and control of your tow vehicle and habitat. Thus, be sure that you have all the information you need to make an informed decision regarding your brakes before getting on the road.

*brake adjustments ...* generally, brakes should be adjusted after the first 200 miles, every 3,000 miles thereafter, and/or as use and performance requires. *We recommend that you have a qualified technician perform all brake adjustments, service and maintenance.*



## TIRES

**size:**            **ST 235/75 R 15 pressure: max 50psi cold,**  
                      **LT 225/75 R 16 pressure: max 80 psi cold (Overland)**

*overview...* Properly maintained tires improve the steering, stopping, traction, and load-carrying capability of your vehicle. Under-inflated tires and overloaded vehicles are a major cause of tire failure. **Maintaining proper tire pressure, tire and vehicle load limits, avoiding road hazards, and regularly inspecting tires for cuts, slashes, and other irregularities are important steps in avoiding tire failure, such as tread separation or blowout and flat tires.** These steps, along with other care and maintenance activities, may improve vehicle handling, help protect you and others from avoidable breakdowns and accidents, improve fuel economy and increase the life of your tires. In sum, you are responsible for making tire safety a regular part of your tow vehicle and habitat maintenance routine. Remember that the time you spend is minimal compared with the inconvenience and safety consequences of tire failure.

*proper wheel nut torque* is essential to safe towing. The wheel and axle systems used in habitats are similar in many ways to those found in motor vehicles. However, they differ in several important ways. First, habitat wheels do not steer, and are subjected to high side load stress when making tight turns around corners. This tends to flex the wheel and loosen the wheel nuts. Wheel nut torque requirements vary depending on the size and manufacturer of the wheel.

### TIRE FUNDAMENTALS

Federal law requires tire manufacturers to place standardized information on the sidewall of all tires. This information identifies and describes the fundamental characteristics of the tire and also provides a tire identification number for safety standard certification and recall matters.

*Sidewall markings and important terms ...* your habitat tires should be marked with either a designation of "ST" (i.e. ST235/75/R15, or LT235/75/R15). The "ST" indicates Standard Habitat Service and designed for habitat use only. The "LT" indicates Light Truck Service and designed to be used on vehicles that are capable of carrying heavy cargo.

*maximum load rating ....* Is the maximum load in kilograms and pounds that each tire can carry.

*maximum permissible inflation pressure ...* is the greatest amount of air pressure that should be put in the tire under normal driving conditions.

*max. load single kg (lbs) at kPa (psi) cold* -This information indicates the maximum load and tire pressure when the tire is used as a single.

*load range ....* identifies the tire's load-carrying capabilities and its inflation limits.

### TIRE TREAD

The tire tread provides the gripping action and traction that helps prevent your vehicle from slipping or sliding, especially when the road is wet or icy. Generally, tires are not safe and should be replaced when the tread is worn down to 1/16 of an inch. *The following chart is a general guide for determining the condition of and maintenance action for your habitat tires:*

*replacement ...* please refer to the tire sidewall on your habitat's standard tires for information regarding proper tire replacement. Be sure to replace your standard habitat tires with "ST" or "LT" designated tires. Note: replacing your habitat tires with non-ST designated tires will void the Limited Warranty. See Limited Warranty section herein. If you have any doubt about the correct size/type to choose, consult with a tire dealer. Please also refer to the manual provided by your specific tire manufacturer for care and use instructions.

*repair ....* the proper repair of a punctured tire requires a plug for the hole and a patch for the area inside the tire that surrounds the puncture hole. Punctures through the tread may be repaired if they are not too large, but punctures to the sidewall should NOT be repaired. Tires must be removed from the rim to be properly inspected before being plugged and patched.

**ALL TIRE REPAIRS SHOULD BE PERFORMED BY A QUALIFIED TECHNICIAN.**

### TIRE PRESSURE AND LOAD LIMITS

Tire inflation pressure is the level of air in the tire that provides it with load-carrying capacity and affects the overall performance of the vehicle. Because tires may naturally lose air over time, or when driven over objects such as potholes or curbs, it is important to check tire pressure monthly and before every trip.

The tire inflation pressure number indicates the amount of air pressure— measured in pounds per square inch (psi)—a tire requires to be properly inflated. Vehicle manufacturers determine this number based on the vehicle’s design load limit, that is, the greatest amount of weight a vehicle can safely carry and the vehicle’s tire size. Excessive loads may lead to abnormal tire flex, tire overheating, and ultimately, tire failure. As travel habitats may be set up and loaded in varying ways, proper air pressure should be determined by referencing the information on your tire. Please also refer to the Tire and Loading Information sticker located at the front exterior of your habitat.

The proper tire pressure for your vehicle is referred to as the “recommended cold inflation pressure.” Proper pressure depends on many conditions – terrain, temperatures, altitude, etc. A “cold” tire in this sense is one that has not been driven on for at least three hours. When you drive, your tires get warmer, causing the air pressure within them to increase. Therefore, to get an accurate tire pressure reading, you must measure tire pressure when the tires are cold or account for the extra pressure in warm tires.

WARNING: Improper tire pressure can quickly lead to excessive wear and dangerous situations.



*tire pressure steps:*

- Locate the recommended tire pressure on the vehicle’s tire.
  - Record the tire pressure of all tires.
  - If the tire pressure is too high in any of the tires, slowly release air by gently pressing on the tire valve stem with the edge of your tire gauge until you get to the correct pressure.
  - If the tire pressure is too low, note the difference between the measured tire pressure and the correct tire pressure. These “missing” pounds of pressure are what you will need to add.
- At a service station, add the missing pounds of air pressure to each tire that is under-inflated.
- Check all the tires to make sure they have the same air pressure (except in cases in which the front and rear tires are supposed to have different amounts of pressure).

*remember:*

Do not exceed the maximum recommended pressure.  
 The air pressure recommended on the tire information placard is for the original standard equipment tires only. Your habitat may be equipped with optional-sized tires. Always follow the pressure recommendations stamped in the tire sidewall for any replacement tire.  
 Rotate tires every 5,000 miles or as recommended by the tire manufacturer.

**WHEEL NUT TORQUE ADJUSTMENTS**

*setting torque value on a dial indicator wrench:*

Make sure your indicator needle is set to “0”.  
 As you apply clockwise pressure to the wheel nut, both needles will show the current amount of torque being applied.  
 When you reach your desired torque value, stop applying pressure and your indicator needle will stay at the highest torque value reached.

*setting torque value of adjustable dial wrench:*

Unlock the handle and set the dial to your desired torque value.  
 Lock the handle back in place.  
 As you apply clockwise pressure to the lug nut, you will hear and audible “click” when the desired torque wrench value is reached.  
 Do not apply further pressure once you hear the “click”.

*pre-trip torqueing procedure:*

Be sure to tighten the wheel nuts and torque to 90 lbs. Follow the torque sequence and torque table provided next:

Wheel Nut Torque Table

	Cricket Wheel
1st Stage	20-25 ft./lb.
2nd Stage	55-60 ft./lb.
3rd Stage	85-90 ft./lbs

- stage 1* Set your torque wrench to the 1st stage value on the Wheel Nut Torque Table. Begin with the appropriate bolt for your wheel (12 o'clock position for 8 and 6 hole wheels and 2 o'clock position for 5 hole wheels) and apply torque to all wheel nuts following the star pattern as shown in the Wheel Nut Torqueing Sequence illustration shown here.
- stage 2* Increase your torque wrench setting to the 2nd Stage value on the Wheel Nut Torque Table. Begin with the appropriate bolt for your wheel and apply torque to all wheel nuts following the star pattern. Following stage 2, the wheel can support the weight of the habitat and may be lowered off of the jack stands.
- stage 3* Increase your torque wrench setting to Final Torque value on the Wheel Nut Torque Table. Begin with the appropriate bolt for your wheel and apply torque to all wheel nuts following the star pattern.
- follow-up* If the wheel was replaced, check the torque again at every 50 miles for the first 500 miles and prior to each trip thereafter.

If you notice a wheel wobbling or hear a rattling sound coming from a wheel, especially at low speeds, a wheel lug may have come loose. This problem is usually caused by improper tightening or by faulty or damaged lug bolt threads. If you have reason to believe a lug nut has come loose, safely stop the vehicle at the side of the road as soon as possible. Put up warning devices. Remove the lug caps and check the tightness of all the lug nuts. If lug bolt threads are damaged or faulty, get professional services help. Do NOT tow the habitat with missing lug nuts or faulty lug bolts.

#### BALANCING, ALIGNMENT AND LUBRICATION

To avoid vibration or shaking of the vehicle when a tire rotates, the tire must be properly balanced. This balance is achieved by positioning weights on the wheel to counterbalance heavy spots on the wheel-and-tire assembly. A wheel alignment adjusts the angles of the wheels so that they are positioned correctly relative to the vehicle's frame. This adjustment maximizes the life of your tires. These adjustments require special equipment and should be performed by a qualified technician.

Wheel bearings should be repacked every 6000 miles or every 6 months. Every time the wheel hub is removed, the wheel bearings must be adjusted. Please refer to manufacturer instructions or schedule maintenance with a qualified technician to repack wheel bearings.

#### TIRE SAFETY CHECKLIST

SEP(1) check tire pressure regularly (at least once a month and before any extended trip/travelling), including the spare tires, if any... Note: When checking air pressure, be sure that all tires have both the correct and identical pressure before getting on the road; (2) check and torque wheel lug nuts regularly; (3) inspect tires for cuts, slashes, punctures and other irregularities at least on a monthly basis and before every extended trip/travelling; (4) remove any foreign objects (i.e. pieces of glass or metal, etc.) wedged in the tread; (5) confirm all tire valves have valve caps; (6) do not overload your tow vehicle or habitat; (7) slow down when having to go over a pothole or other object in the road, and avoid running over curbs and other foreign objects in the road and when parking if you can safely do so; (8) Replace tires when tread depth approaches and/or reaches 1/16 of an inch; and (9) have a qualified technician perform tire service, maintenance and adjustments as needed.

**CRICKET DESCRIPTION**

(regular Cricket shown)

TAXA IS CONSTANTLY MAKING VIDEOS TO HELP YOU GET TO KNOW AND USE OUR HABITATS  
SEE TAXA OUTDOORS CHANNEL ON YOUTUBE -

<https://www.youtube.com/channel/UCMsYph44ocmHwLkD1F685JA>

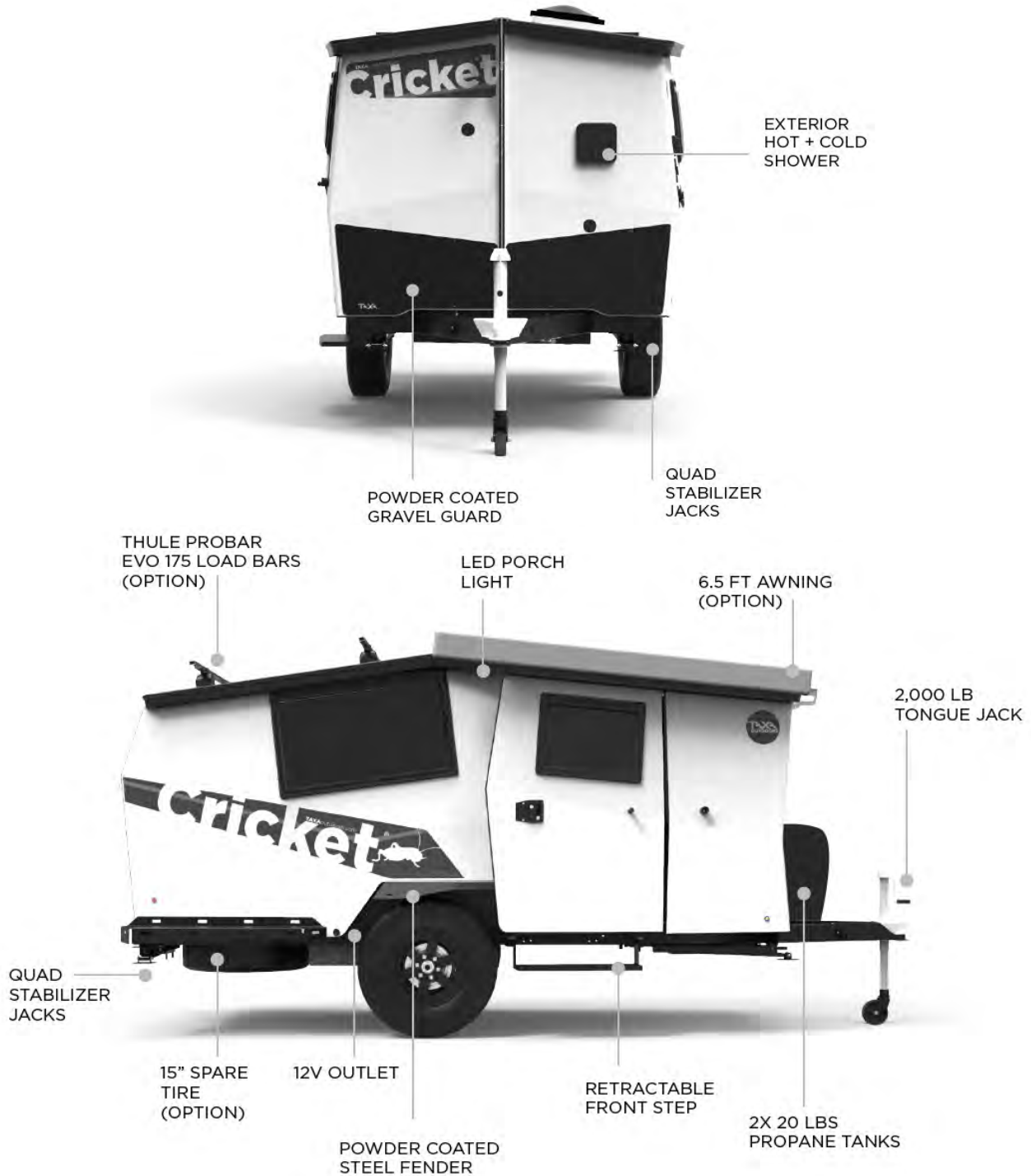

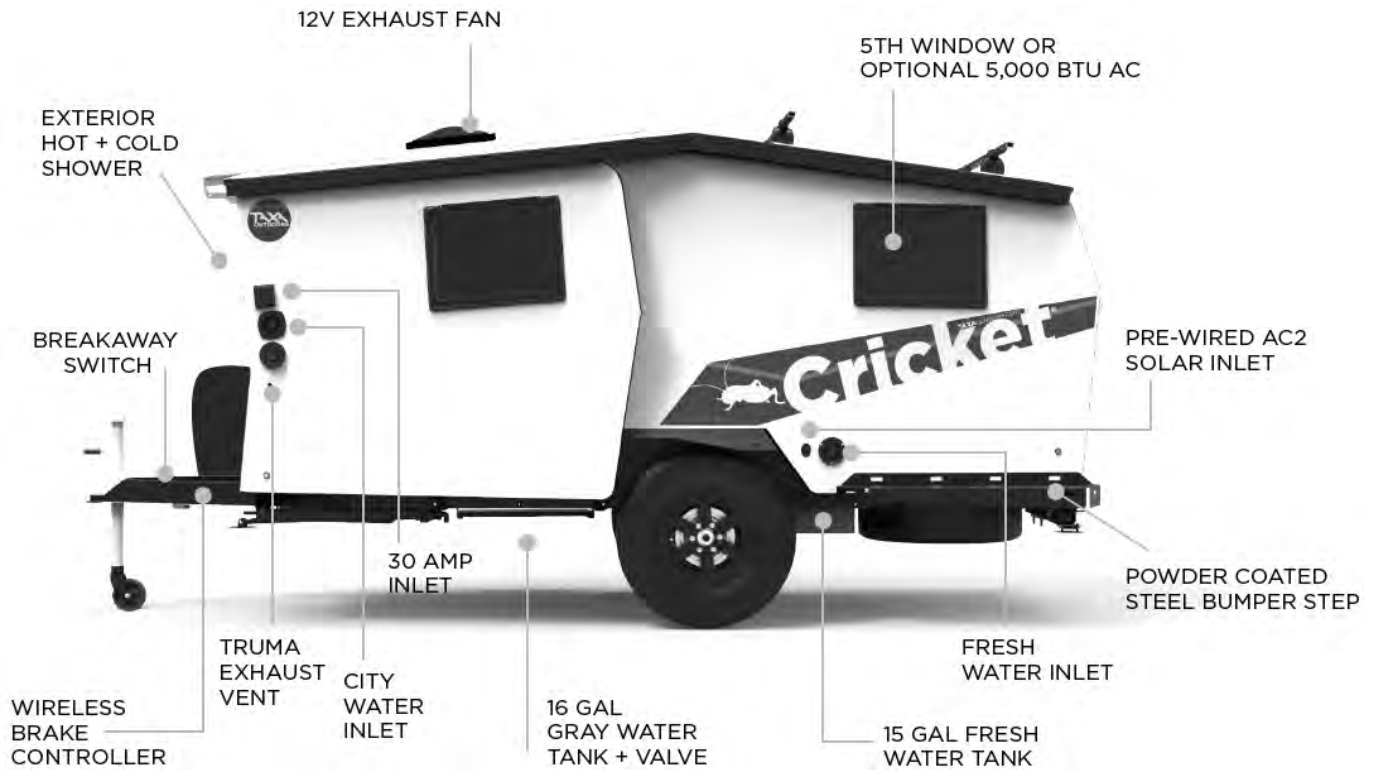
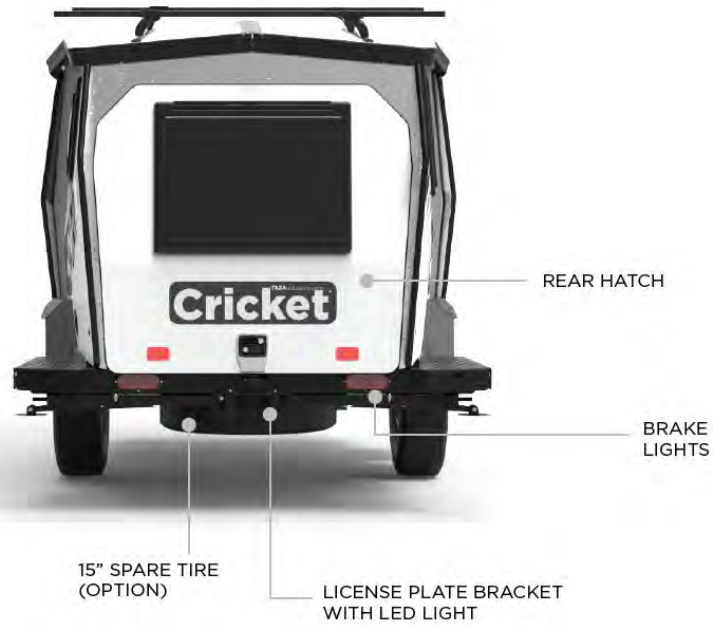



**Cricket**  
2021

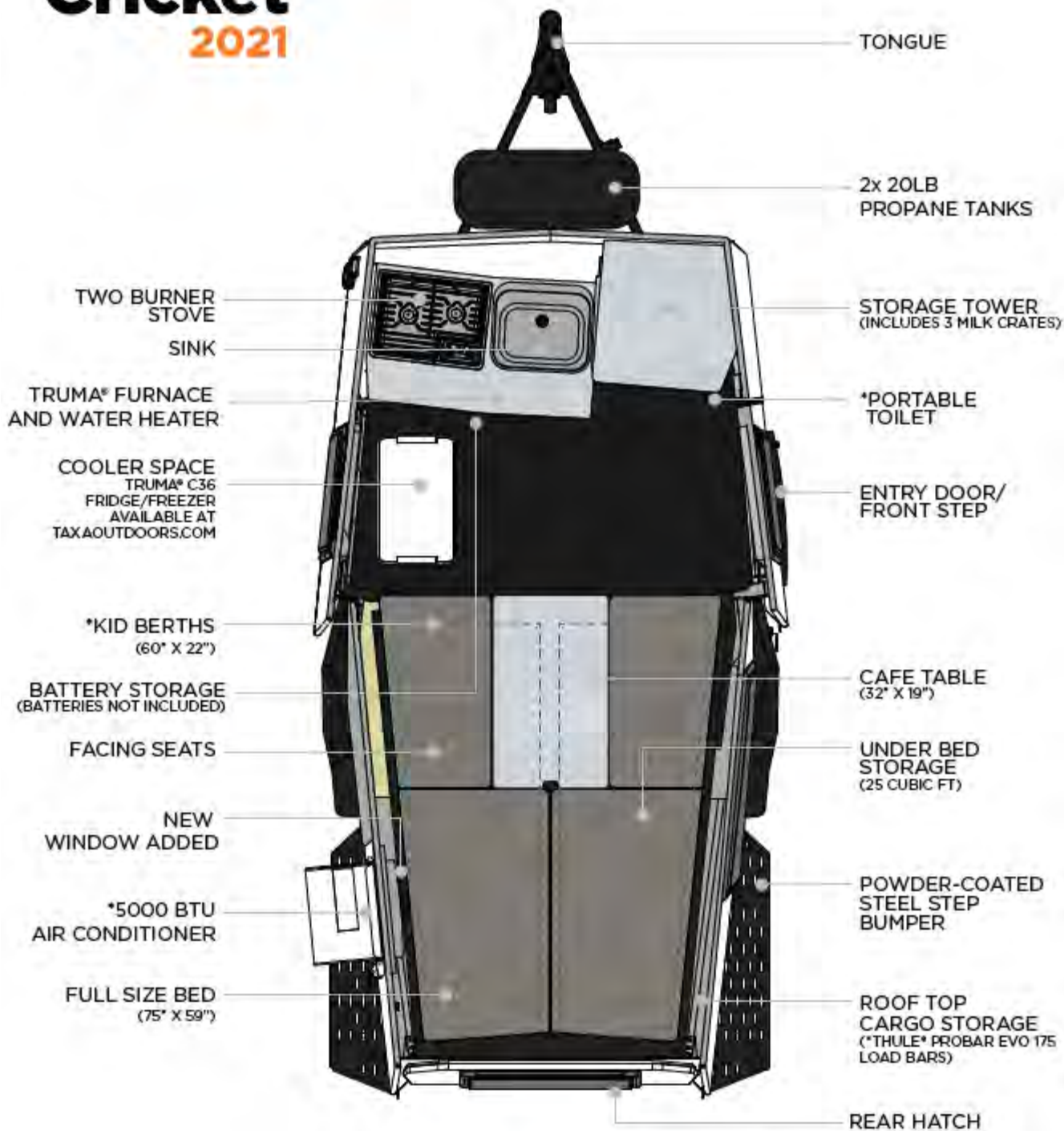

\*OPTIONAL FEATURE

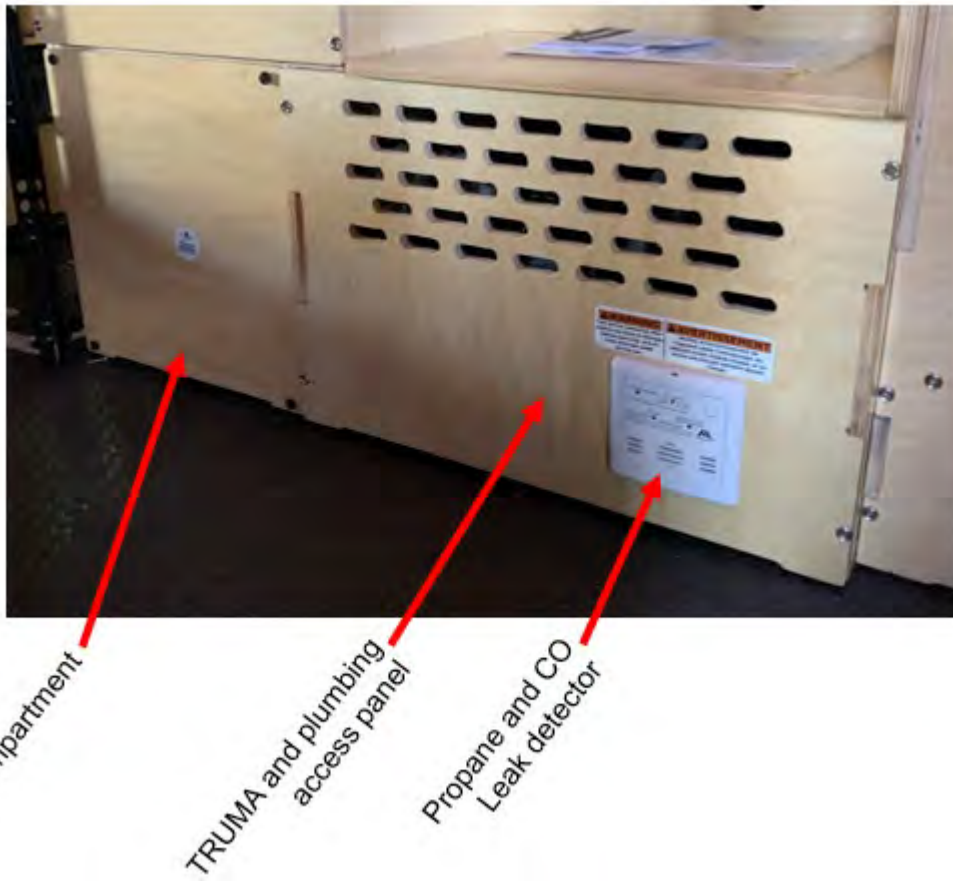
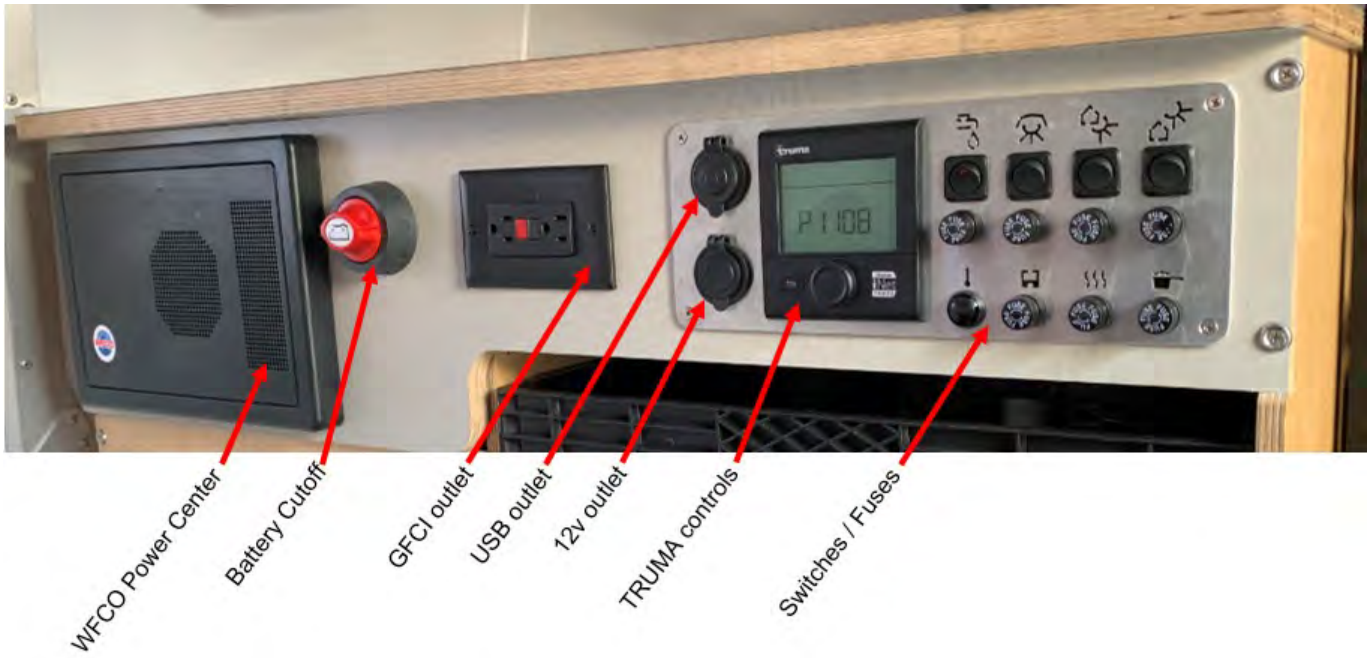



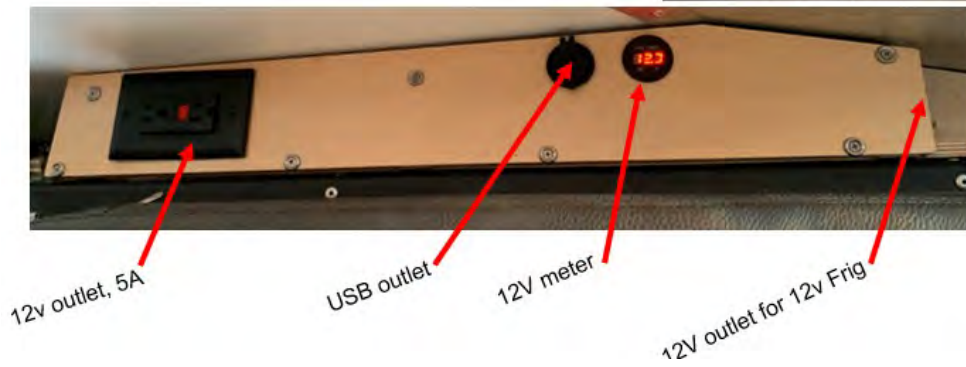
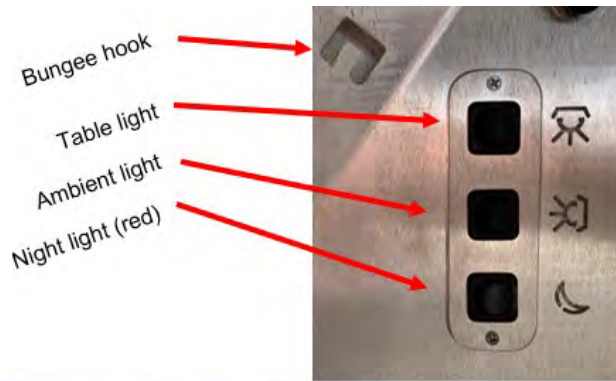



Milk crate drawers

Porta Potti OR  
third Milk crate

Bungee "lock"  
for driving



Use as a drawer  
or  
take it right outside



optional AC  
replaces window,  
to use plug into  
outlet at wheel well  
with habitat  
plugged in to shore  
power



Remove AC rain  
cover before usage



AC ready to cool!

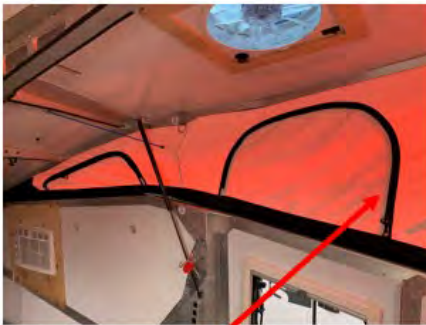

Zippers are fully adjustable  
for ventilation or  
inclement weather



If all the way open  
Use toggles to make neat





**PLUMBING SYSTEM**  
PROPANE / TRUMA CRICKET

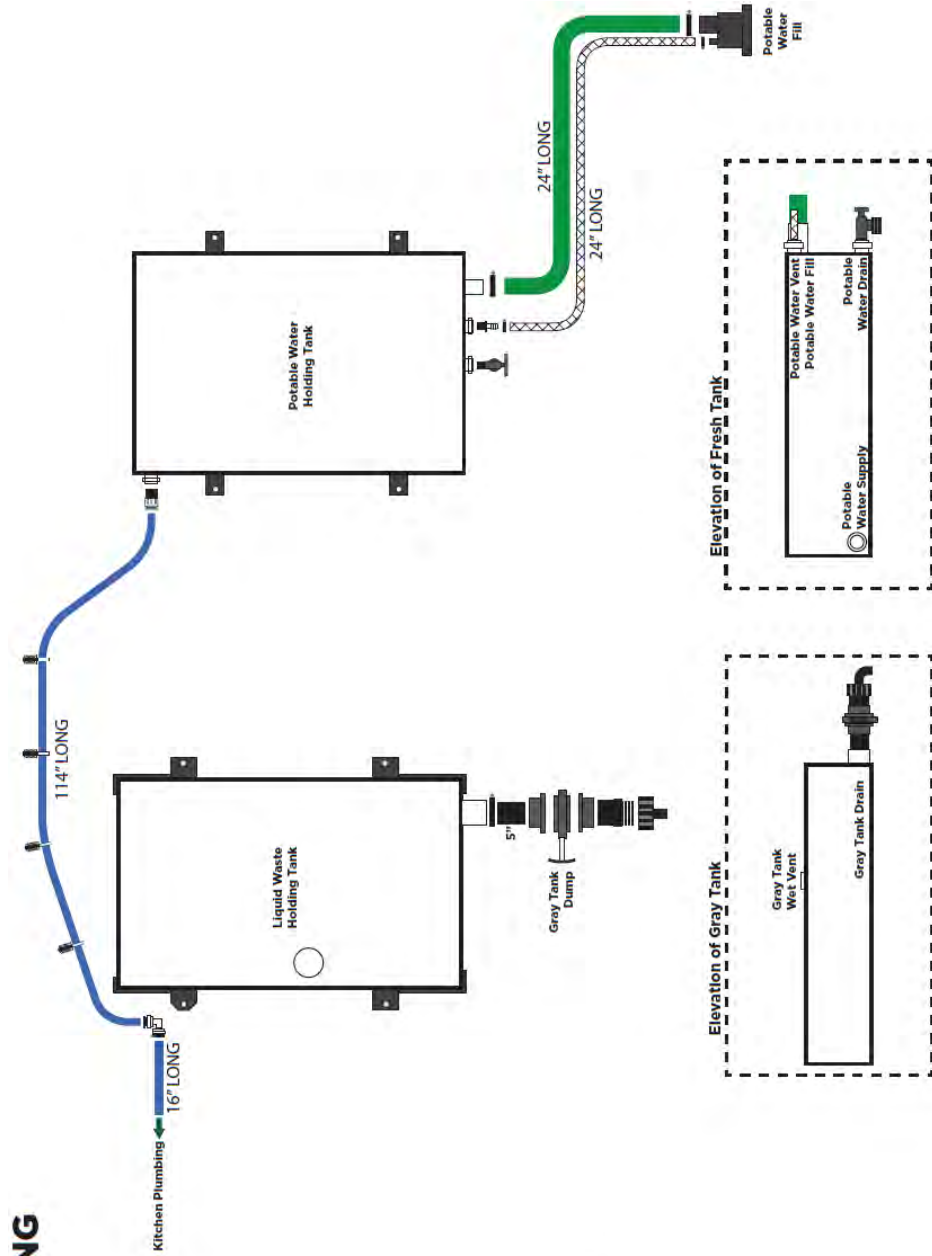

**CHASSIS PLUMBING**  
**C-10-1000-R4**

1/2" ABS (SP-D29)	
Water Fill Hose 1-1/4" (LH-T82)	
1/2" LLDPE Tube (LH-TT1)	
1/2" Flex Tube (LH-T12)	
Slip-90 (SP-R04)	Potable Water Vent (SP-C11)
1/2" Male to Slip (SP-R01)	LIQUID Drain Valve (SP-D01)
Slip off (SP-D03)	Slip Flange (SP-D02)
Barb Adapter (SP-D05)	1-1/2" Male ABS Adapter (SP-D28)
1/2" Male to 1/2" Tube (SP-P01)	1-1/2" Cap (SP-L31)
84 Clamp (SP-A17)	Zip Tie, Reinforced (SP-B13)
820 Clamp (SP-O12)	Gray Tank Hanger, PS (LH-R08)
820 Clamp (SP-O13)	Gray Tank Hanger, DS (LH-R07)
Fresh Tank Hanger (LH-R07)	
GRAY TANK (LP-T24)	
FRESH TANK (LP-T24)	

**Note:**  
1. All drain lines sloped 1/8" per foot.



*overview* .... your habitat's fresh water system is a vital part of your traveling life while on the road. Your CRICKET is equipped with a dual supply water system: (1) the demand fresh water system operates from the habitat's supply tank and water pump; and (2) the "city water" hookup allows you to connect to a pressurized external water system at a campground.

Fresh water is stored in a plastic tank located below the floor of the habitat. The tank is vented to allow proper and complete filling. The drain valve allows you to drain the tank. Always drain the tank before storing the habitat for long periods. When the habitat is in continuous use for an extended period (generally over a month), inspect, drain and clean the tank regularly. The entire fresh water system should be sanitized before the first use, the first use each camping season, and after a reasonable period of nonuse, and of course if the system is contaminated. See below for more information on sanitation and routine tank maintenance.

The easiest way to keep the tank full of clean water is to use (1) a dedicated clean potable water hose and (2) a filter system inline with your hose . You will need to purchase these two (2) items separately.



Note regarding your fresh water hose: *Never use the hose for anything except filling the freshwater tank or connecting to city water, and always store it independently of other hoses and plumbing supplies. Also remember that nothing should pass through the fresh water hose unless it first passes through a filter inline with the hose.*

Non-toxic, FDA-approved drinking water hoses are inexpensive and work well. They are typically white in color with a light blue stripe, which helps to identify the hose and serves as a reminder to keep it separate from other hoses or hardware, especially those used for waste drainage. You may consider using a special FDA-approved hose as many common garden hoses are made of reground rubber. As clean water hoses age and compounds break down, you may notice taste and odor-related impurities in your fresh water supply. To help counteract this process, be sure to screw the two (2) ends of the fresh water hose together following each use. This also prevents dirt or other matter from entering the hose.

Do NOT fill the potable water tank too quickly as air can be trapped in the tank if you do. Fill the tank slowly, allowing the air inside to escape through the inlet vent and reducing the possibility of water gushes and/or spray back.

#### IMPORTANT PLUMBING CONSIDERATIONS AND COMPONENTS

*water pressure, pressure regulator (not included) and check valve* .... The recommended pressure for your plumbing system is <55 psi. Water pressure frequently varies depending on your location and water pressure exceeding 55 psi can damage your plumbing system. Don't worry though! Installed as part of your Cricket's fresh water inlet is an integrated water pressure regulator that is automatically used when connecting to a city/campground water supply.

City or campground water systems may operate at pressures that can damage the water system in your habitat and/or cause the water pump to fail. **WARNING: If water pressure at your site EXCEEDS 125 psi, you will have exceeded the capacity of your water pressure regulator.**

*More information about your water pump* ... your water pump is generally referred to as a "demand" pump, operating when it detects a pressure drop in the water lines. This is similar to, for example, the pressure being restored after a sink faucet is turned off. If the indicator light is ON at the kitchen switch panel, the water pump is operational. Many campers only turn the pump on

when using the plumbing - turning it off after usage. The pump vibrates and makes a humming noise when in operation.

*prepping fresh water tank for use ...* (1) fill the fresh water tank as instructed; (2) turn on the water pump switch; (3) Turn on the sink faucets both hot and cold, allowing time for the water heater to fill ... Note: be sure that your faucet is set to engage hot water flow. (4) turn off each sink faucet as the water flow becomes steady and free of air (stops sputtering, and a solid stream of water flows from the faucet );(5) allow the water pump time to stop running ... the water pump should stop running approximately 5 minutes after the sink faucets are turned off; and (6) the system is now ready for use.

*water heater ...*

your Cricket is equipped with the TRUMA COMBI system – a combined propane furnace and HW heater. Please refer to the TRUMA manual for complete instructions and maintenance procedures. You can find the appropriate manual on our website at - <https://taxaoutdoors.com/manuals/#appliances-accessories>.

The controls for the TRUMA are electric and are located in the kitchen switch panel.

For your convenience here are the “quick start” instructions for using your TRUMA:



**CP Plus Functions**

Adjust room temperature - Range: 40-86°F (5-30°C)

Select energy mode

- a) LP gas
- b) MIX 1\* - Electricity 850W + Gas
- c) MIX 2\* - Electricity 1700W + Gas
- d) EL\* - Electricity 850W
- e) EL\* - Electricity 1700W

\*Truma Combi eco plus and comfort plus

Adjust water temperature

- a) **boiler** – Hot water generator is on. Icon flashes until desired temperature is reached.
- b) **eco** – Water temperature is 104°F (40° C)
- c) **hot** – Water temperature is 140°F (60° C)
- d) **boost** – Boiler content is heated quickly (boiler priority) for up to 40 minutes. The water temperature is then kept at the higher level (about 144° F (62° C) for two subsequent heating cycles. When the water temperature is reached, the room is heated again.



**CP Plus Functions – Cont.**

Set clock to current time

Set time switch  
Set a start time and end time for room temperature, water temperature, energy mode and fan speed set points.

Settings  
**Index** - Show version number of connected device  
**Bright** - Adjust backlighting  
**Lang** - Adjust language  
**12-24h** - 12/24 hour mode  
**Temp** – °F or °C  
**Offset** – Calibrate temp offset  
**Pr set** – Factory reset

Select fan speed

- OFF** – Fan is switched off (If furnace mode OFF)
- a) **VENT** - Circulating air (If furnace mode OFF)
- b) **ECO** - Low fan speed
- c) **HIGH** – High fan speed
- d) **BOOST** – Fast room heating. Available if the difference between the selected and current room temperature is >18° F (10° C)



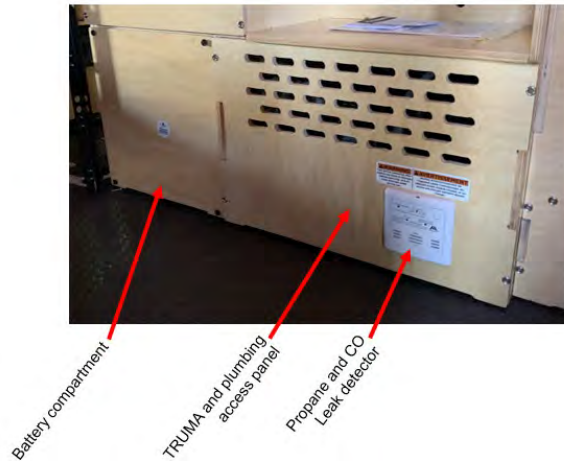

Your TRUMA COMBI is located at the bottom of your kitchen core behind a vented access panel (that same panels holds your propane and CO detector module!). To the left of the TRUMA is the battery compartment

If your TRUMA is mysteriously not working despite all your attempts at following directions the most likely culprit, after checking that propane is turned on, is a small switch on top of the unit that must be in the ON position for gas to flow and ignite.



switch location (located on flat portion of right side top). The switch is ON, when the front (closest to inside of habitat) of the switch is pushed down.

## MAINTENANCE AND SANITATION

*fresh water tank and system (overview)* ... potable water (suitable for consumption) does NOT stay potable for a long period of time. Thus, be sure to exercise caution when deciding whether to use your stored water for drinking. We recommend that you be conservative in making this determination. If uncertain about the state of water in your fresh water tank, make every reasonable effort to use your stored water for washing, rinsing, and cleaning only. Regardless, you must diligently maintain your water system, emptying and replacing your fresh water periodically. We also recommend that you separately purchase and install a water purification system to attach to the sink faucet or at the city water inlet hose, especially if you plan on consuming your stored water. See below discussion regarding sanitation.

### *filling the freshwater tank ...*

(1) prepare the inlet on the driver's side panel of the Cricket; (2) Connect one end of a potable water transfer hose to a water supply, turn on the water supply and let the water run until it is clean and clear; (3) Turn off the water supply, and place the other end of the transfer hose into the fresh water inlet located on the side of the habitat; (4) Turn on the water supply and fill the tank until tank is full. Avoid overflowing tank as this can fill the vent tube with water. If the vent tube gets full of water the tank can become difficult to fill. (5) Remove and store the hose; and (6) slide cover cap back onto the fresh water tank inlet.

*city water systems (overview)* ... city water systems are connected using your potable water hose at a hookup located on the exterior wall of the habitat. Campground water systems have varying pressures, some of which can be too high for your habitat's plumbing system. A pressure regulator is built in to your Cricket that can handle most situations. Please also see discussion of pressure regulators below.

Always connect to a quality water supply. A water supply delivered as potable is more likely to have been properly tested. If

camping at a site with a water well, look for labels and other markings that reflect testing and approval dates. If you are unable to determine this information, be on guard and use caution before using the water supply provided at the site.

*city water (connecting) ...* (1) Set the water pump switch located on interior panel to OFF; (2) get your fresh water hose, placing one end at the hookup located on the exterior wall of the habitat; (3) Turn on the site water supply, allowing the water to flow until it is clean and clear; (4) Turn off the site supply valve and connect the other end of the fresh water hose to the site water supply; and (5) Turn on the site supply valve. You will not be using the Cricket' water pump when using city water.

**IMPORTANT PRECAUTIONS** Whenever you leave the habitat for more than 10-15 minutes, be sure to turn off the water pump (see kitchen switch panel and accompanying indicator light) and/or shut off the city water supply. A sudden, unexpected leak in the water system will allow the water system to run freely and flood the habitat.

Be sure to turn off the water pump while travelling/towing. If not, a faucet may open while travelling, causing fresh water to escape. If you leave the sink drain plugged, the sink will overflow causing the interior of the habitat to be flooded. Always set the water pump to OFF with an empty fresh water tank. Otherwise, it may destroy the pump and cause a blown circuit.

*to empty the fresh water tank ....* The valve for the fresh water tank is located beneath the habitat directly connected to the bottom of the white tank. It is white in color and the valve is white. Turn the valve to open and close when it has finished draining.

*wastewater system ...* The Cricket has a GREY water holding tank (for sink and optional shower drainage). It does NOT contain a BLACK water holding tank (for septic waste). Grey waste is contained in a "grey water" holding tank. NOTE: Rules regarding proper waste disposal vary, sometimes greatly, from site to site. Please be sure to educate yourself on the waste disposal rules of your particular site / location and follow them.

*to empty your grey tank....* The grey tank valve is indicated by a sticker on the exterior of the habitat, located on the driver's side panel in front of the wheel. Pull the T-handle to open the valve. Close when grey tank is empty.



*Hand shower / hose ...* your Cricket has one a shower! The exterior shower is located on the front driver's side behind a small square black door. Behind this is a hot and cold water valve and a Quick Disconnect (QD) valve to insert the blue coiled hose of the shower wand. The brass end on the hose simply pushes into the QD receptacle – a click will indicate it is secure.



To remove the hose after use push the nickel ring in (towards habitat) and the brass end should pop out. Hose off your head, your feet, your dog, etc. Use an exterior privacy enclosure for a full on shower if you like.

That pink tag in the picture has instructions for winterizing. They are repeated here:



*"This faucet contains backflow prevention. Faucet must be drained for storage or if freezing weather is expected.*

*To drain: 1. Disconnect water supply to the vehicle. 2. Open both Hot and Cold valves. 3. Insert flexible spout or coil hose with spray nozzle removed into quick disconnect. 4. Hold open end of hose or spout near ground and drain system. 5. Preferred method: open faucet as above and blow out entire water system with pressurized air or pump entire system with RV fresh water safe anti-freeze."*

*Porta potti ... your Cricket may have an optional portable toilet. Utilizing such a toilet rather than a Black water tanks gives you the freedom to empty into an RV dump station OR a pit toilet OR your home toilet with equal ease. Refer to and follow the manual associated with the toilet.*

*Routine sanitation process .... Be sure to periodically (between trips and/or every few months) conduct routine maintenance on your water system to keep it in good working order. There are many ways to do this and many supporting products from the RV industry.*

*Empty the water heater between uses by:*

- a. draining the fresh water tank.*
- b. turning on the water pump and running the sink faucet on HOT til there is sputtering.*

*Empty the water heater for storage **or for freezing temperatures by:***

- a. draining the fresh water tank.*
- b. turning on the water pump and running the sink faucet on HOT til there is sputtering.*
- c. opening drain valve on TRUMA*

For more details refer to the TRUMA manual. As an extra precaution and to avoid damage to your system we reprint the winterizing page from the manual here:

## Draining the water container

**NOTICE** Damage to the Truma Combi furnace caused by freezing!

- The Truma Combi furnace does not feature a frost-protection function. The water container must be drained if the recreational vehicle (RV) will not be used whenever there is a risk of frost.

**No warranty claims for frost damage.**

**i** To make sure that all water drains properly from the water container, place a big enough vessel underneath the drainage socket of the drain valve (> 2.64 gallons (10 liters)).

1. Use the main switch or pump switch to switch off the power to the water-pump assembly.
2. Turn off or disconnect the city water connection, if present.
3. Open all water release points, e.g. cold and hot water faucets, showers, toilets.
4. Open the drain valve (refer to "Opening the drain valve" on page 10).

The water container will drain via the drainage socket of the drain valve.

## Winterizing

**NOTICE** Severe damage to the plumbing components and the Truma Combi furnace! Damage due to freezing or an unsuitable winterizing fluid is not covered by warranty.

- Follow the recommendations below if the Truma Combi furnace will be stored under freezing conditions or for an extended period of time.
- Winterize the Truma Combi furnace at the start of the winter season or before traveling to a location where freezing conditions are likely.

For winterizing, drain the Truma Combi furnace, refer to "Draining the water container" on page 13.

After draining the water, the Truma Combi furnace is protected against freezing conditions.

## Optional: Winterizing the RV with a winterizing fluid

**i** Winterizing the RV with a winterizing fluid is only possible with an installed bypass kit (not in scope of supply), refer to the RV manual.

1. Drain the water container (refer to "Draining the water container" on page 13).
2. Turn the valves of the bypass kit according to the supplier's or RV manufacturer's guidelines.
3. Flush the water system with a suitable winterizing fluid according to the supplier's or RV manufacturer's guidelines.

**i** Before using the Truma Combi furnace again in hot water mode, remove the winterizing fluid and flush the water system with potable water.

## Winter operation

To operate the Truma Combi furnace in potentially freezing conditions, the following requirements must be ensured:

- There must be sufficient LP gas (propane; fuel inlet pressure 11 - 13 in. wc (27.4 - 32.4 mbar)) in the tank.
- In addition, the Truma Combi eco plus and the Truma Combi comfort plus models require a supply voltage of 120 V if they are to be operated in electric or mixed mode.
- For hot water operation, the water container must be filled (refer to "Filling the water container" on page 11). You must leave the furnace powered ON whenever freezing might occur.

Winter operation will not protect the RV's entire plumbing system. The RV must be designed for freezing conditions.

## ELECTRICAL SYSTEM

Your Cricket's electrical system is primarily a 12 Volt Direct Current (DC) system and has 120V AC outlets that operate only when attached to shore power. This is explained as follows:

### 12V DC OVERVIEW

Your habitat 12 Volt system is powered by a 12V battery or batteries (see "Battery" section). Most installed appliances, aside from air conditioning, operate fully with 12V power.

*7-pin connector* ... use your 7-pin connector plug to connect your tow vehicle and habitat electrical systems. This cord is located at the front of your habitat and plugs into a receptacle provided in your tow vehicle's hitch package. In addition to charging your habitat battery while driving, this connection powers your habitat lights and electric brakes (your Cricket has a wireless proportional brake controller installed). **BE SURE TO PLUG THE 7 PIN CONNECTOR WITH THE PROPER HOLES AT TOP AND BOTTOM. FAILURE TO DO SO MAY DAMAGE YOUR HABITAT WIRING AND ELECTRIC BRAKE SYSTEM.**

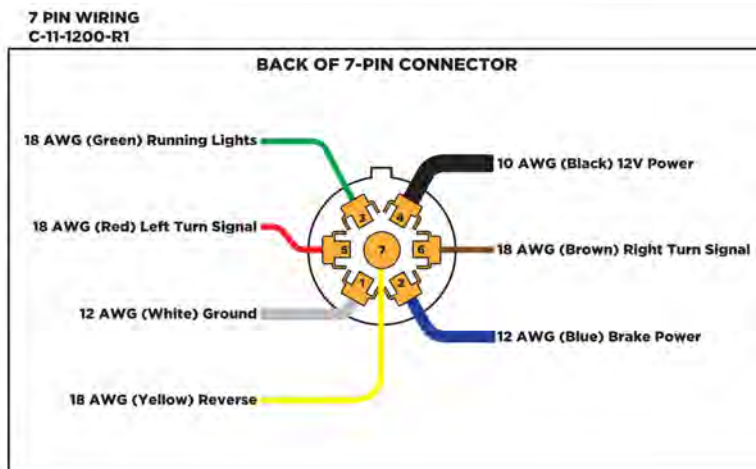

**We recommend disconnecting the 7-pin connector from the tow vehicle when camping**

When hitching and unhitching, be sure to move the 7-pin connector cord so it does not get damaged by, for example, the hitch and/or pin box. Do not allow the cord to drag on the ground and cover with a rag or soft cloth when not in use. Keep the connector clean and dry, and follow manufacturer instructions for cleaning if necessary. See also "Hitching" section for further discussion regarding your 7-pin connector.

If you have a mounted air conditioning unit, it will operate only on external 120V power from a home, campground or a generator. There is a dedicated 120V outlet located close to the air conditioner's location. *Important Note: you must refer to the manuals and other instructions of any and all appliances, add-ons and/or accessories regarding their respective electrical requirements.*

*120V circuit breakers* ... 120V circuit breakers are located inside your converter/charger box, which is located on the driver's side rear of the habitat interior beneath the berth. They control the circuit between the 120V inlet and the 12V power provided in the habitat. If your circuits trip because of overload, reduce the load and reset the breaker.

## PROPANE



**Propane WFCO  
C-11-9200-R1**

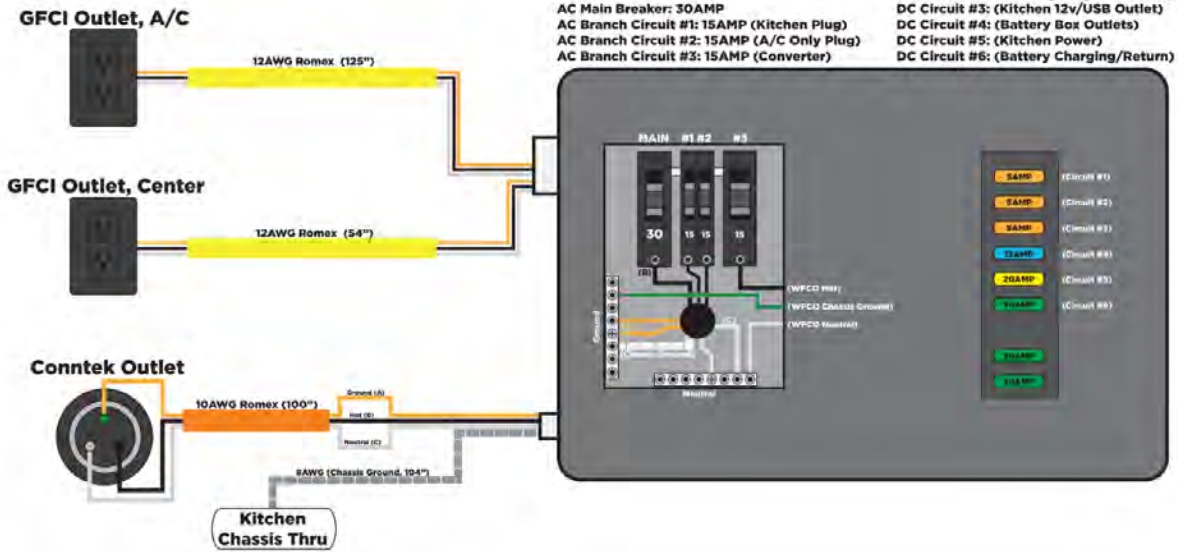

**AC Main Breaker: 30AMP**  
**AC Branch Circuit #1: 15AMP (Kitchen Plug)**  
**AC Branch Circuit #2: 15AMP (A/C Only Plug)**  
**AC Branch Circuit #3: 15AMP (Converter)**

**DC Circuit #1: (Exterior 12v Outlet)**  
**DC Circuit #2: (Roof Lighting and LP/CO)**  
**DC Circuit #3: (Kitchen 12v/USB Outlet)**  
**DC Circuit #4: (Battery Box Outlets)**  
**DC Circuit #5: (Kitchen Power)**  
**DC Circuit #6: (Battery Charging/Return)**

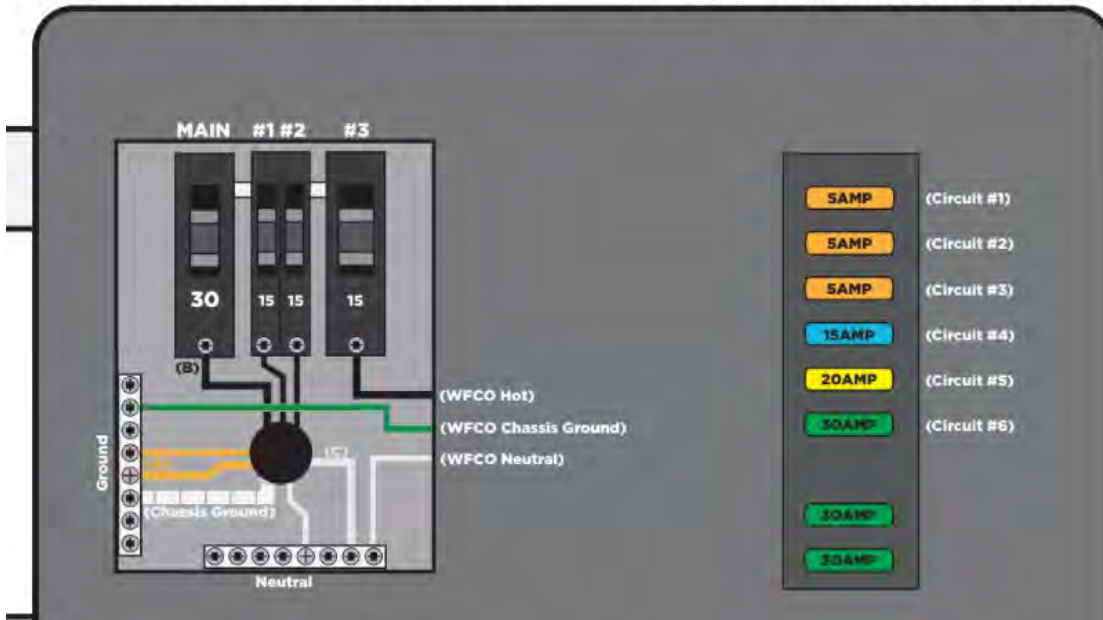

**PROPANE WFCO BOX ELECTRICAL  
C-11-9100-R1**

White 8AWG	LN-W24	
White 10AWG	LN-W15	
Red 10AWG	LN-W20	
Green 12AWG	LN-W33	
Yellow 12AWG	LN-W32	
Gray 14AWG	LN-W28	
10AWG Romex	LN-W04	
12AWG Romex	LN-W13	
Blue 14AWG	LN-W35	
Brown 14AWG	LN-W21	
10-12AWG Butt Connector	SP-129	
14-16AWG Butt Connector	SP-133.2	
Power Inlet, Black	SP-G09	
WFCO, Black	SP-N69	
GFCI Outlet, Black	SP-G06	

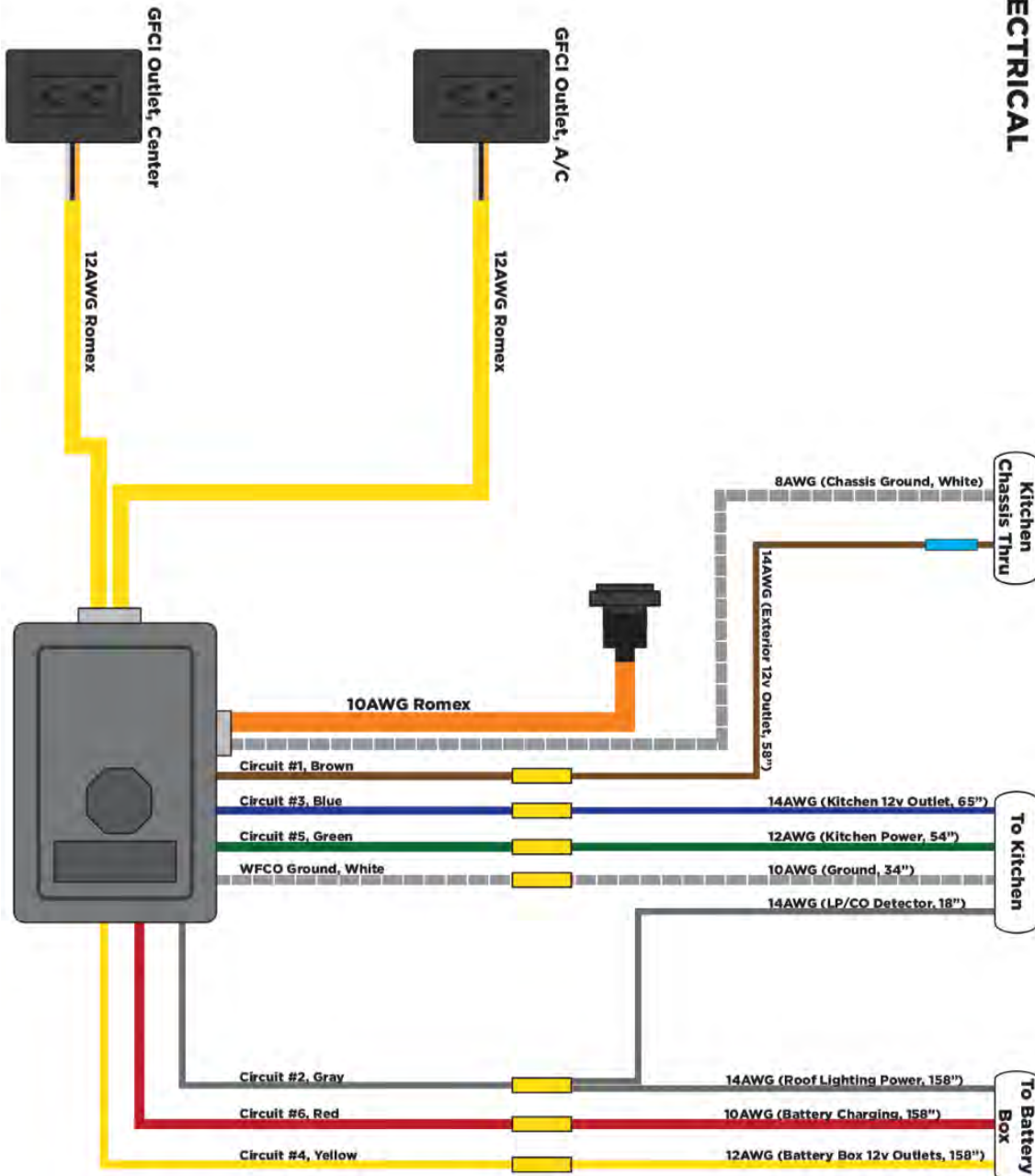



**PROPANE KITCHEN  
ELECTRICAL  
C-11-9300-R1**

White 8AWG	LN-W24	8 AWG (60") White
White 10AWG	LN-W15	10 AWG (60") White
White 12AWG	LN-W16	12 AWG (60") White
White 14AWG	LN-W17	14 AWG (60") White
White 18AWG	LN-W18	18 AWG (60") White
Blue 14AWG	LN-W25	14 AWG (60") Blue
Blue 18AWG	LN-W26	18 AWG (60") Blue
Green 12AWG	LN-W23	12 AWG (60") Green
Orange 18AWG	LN-W19	18 AWG (60") Orange
Red 14AWG	LN-W29	14 AWG (60") Red
Red 18AWG	LN-W31	18 AWG (60") Red
Large 80A Red Ring Terminal	SP-137	Large 80A Red Ring Terminal
Small Yellow Ring Terminal	SP-125	Small Yellow Ring Terminal
Yellow Male OD	SP-156	Yellow Male OD
Yellow Female OD	SP-152	Yellow Female OD
Blue Female OD	SP-151	Blue Female OD
Blue Female OD	SP-150	Blue Female OD
Blue Female OD	SP-145	Blue Female OD
Blue Female OD	SP-141	Blue Female OD
Blue Female OD	SP-133	Blue Female OD
Signal Red Ring	SP-133	Signal Red Ring
Red from OD	SP-126	Red from OD
Red from OD	SP-146	Red from OD
187 Wide OD	SP-146	187 Wide OD
BUTT CONN.	SP-132	BUTT CONN.
23.18 AWG	SP-132	23.18 AWG
Bus Bar	SP-H09	Bus Bar
12V Outlet	SP-H05	12V Outlet
USB Outlet	SP-H26	USB Outlet
Fuse Holder	SP-H04	Fuse Holder
Switch	SP-L21	Switch
Switch w/LED	SP-L20	Switch w/LED
Water Pump	SP-M36	Water Pump
Stove/Sink	LP-P24	Stove/Sink
Furnace/ Water Heater	LP-P23	Furnace/ Water Heater
LP/CO Detector	SP-H09	LP/CO Detector

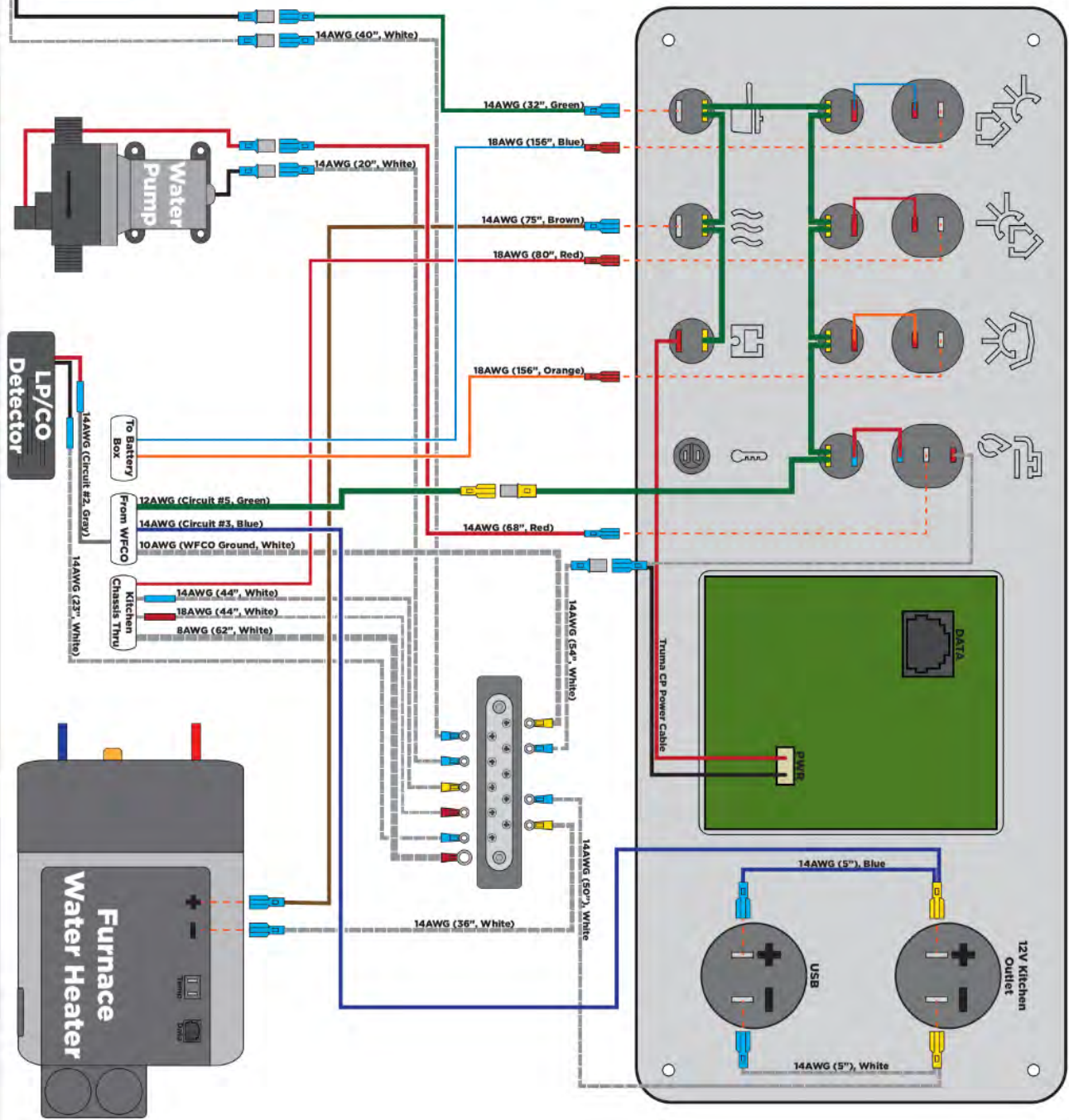

PROPANE

**BATTERY BOX ELECTRICAL**  
**C-11-4000-R5**

White 8AWG	LN-W24	
White 10AWG	LN-W15	
White 12AWG	LN-W16	
White 14AWG	LN-W17	
Red 10AWG	LN-W20	
Red 12AWG	LN-W12	
Red 18AWG	LN-W31	
Black 10AWG	LN-W02	
Yellow 12AWG	LN-W32	
Yellow 14AWG	LN-W27	
Green 18AWG	LN-W11	
Orange 18AWG	LN-W10	
Purple 18AWG	LN-W14	
Blue 18AWG	LN-W06	
Blue Connector, 12-10AWG	SP-129	
Blue Connector, 12-10AWG	SP-132, 2	
Red Connector, 22-18AWG	SP-128	
Ring Terminal, 1/4" Stud, 8AWG	SP-137	
Ring Terminal, 3/8" Stud, 12-10	SP-132, 4	
Ring Terminal, 3/8" Stud, 12-10	SP-132, 1	
Ring Terminal, #10 Stud, 12-10	SP-132, 3	
Ring Terminal, #10 Stud, 16-14	SP-134, 1	
OD Female Flag	SP-150	
30AMP Breaker	SP-H16	
Bus Bar	SP-H09	
Solar Inlet	SP-P21	
Battery Switch	SP-G24	
12V Outlet	SP-H05	
USB Outlet	SP-H26	
Voltmeter	SP-H27	
Rocker Switch	SP-L21	
Fuse Block	SP-H14	
Fuse, 5AMP AGC	SP-H11	
Battery	LP-802	

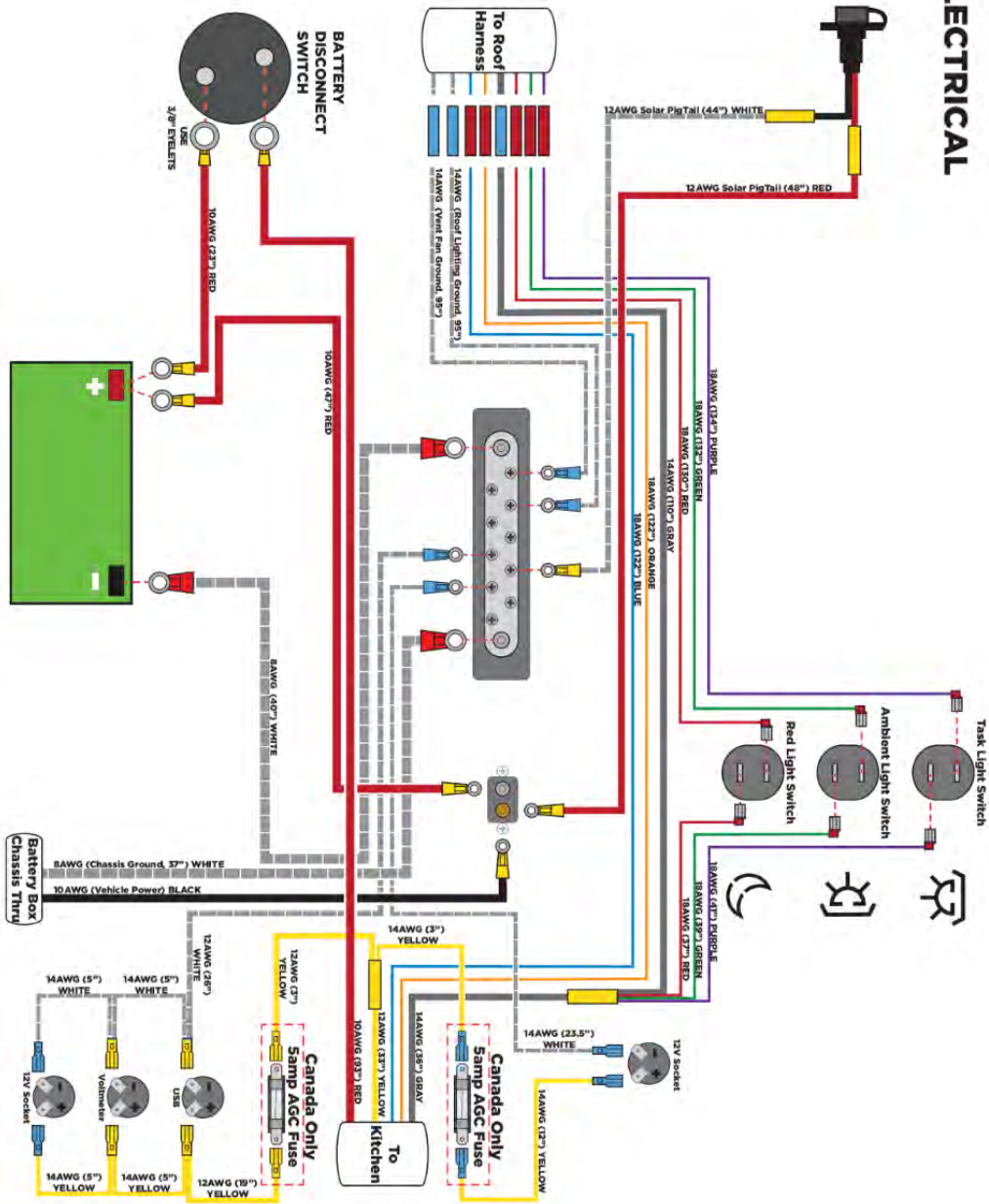

**ROOF HARNESS  
C-11-5000-R3**

14AWG Gray Wire	LN-W28	
18AWG Orange Wire	LN-W10	
18AWG Green Wire	LN-W11	
18AWG Purple Wire	LN-W14	
18AWG Red Wire	LN-W11	
18AWG Blue Wire	LN-W06	
14AWG White Wire	LN-W17	
18AWG White Wire	LN-W18	
Yellow Butt Connector	SP-09	
Blue Butt Connector	SP-03.2	
Red Butt Connector	SP-028	
15cm LED Strip	SP-L12	
20cm LED Strip	SP-L13	
45cm LED Strip	SP-L11	
100cm LED Strip	SP-L14	

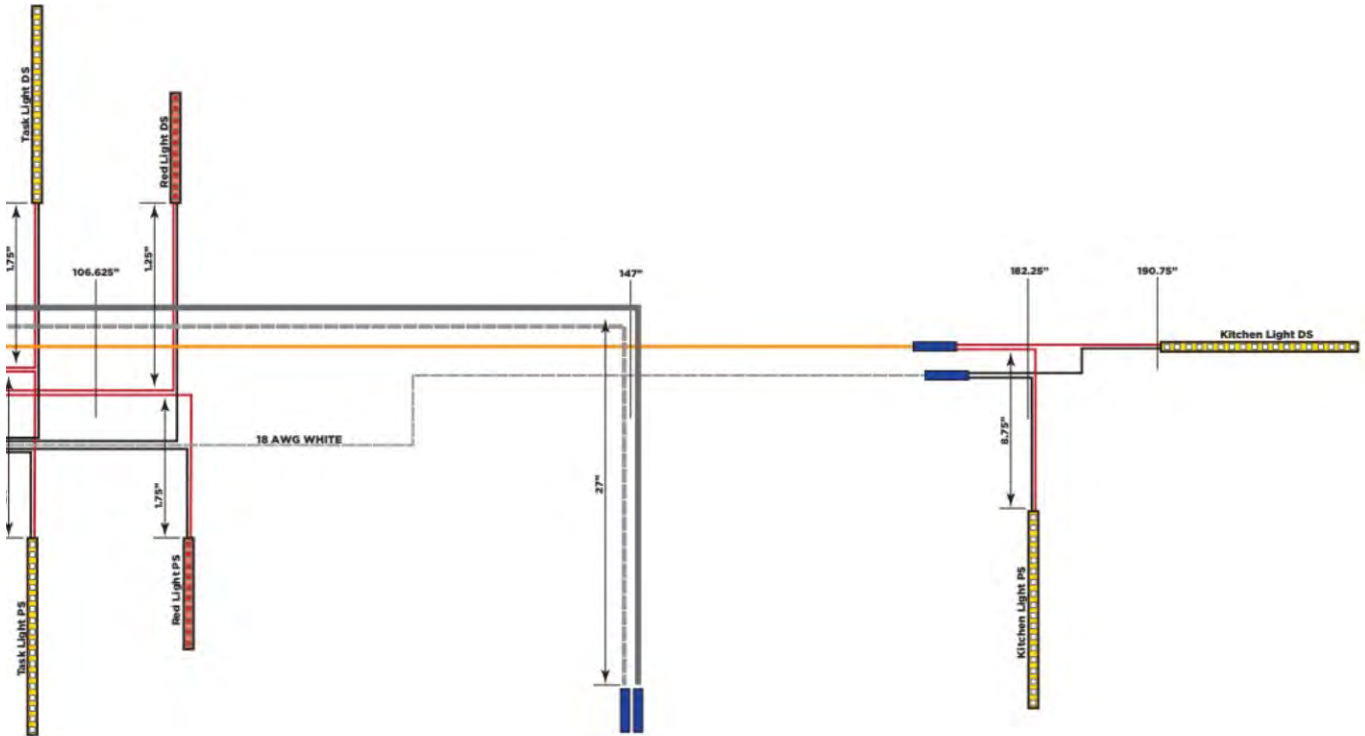
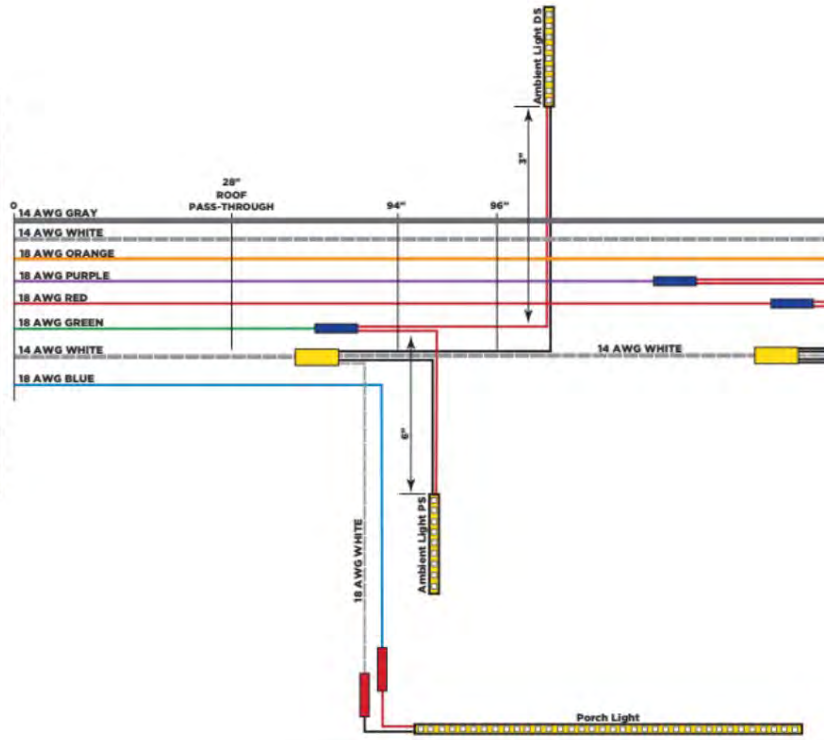



## BATTERY

*overview ... a group 24 or 27 battery* is generally specified and installed by your dealer. There is room for two (2) such batteries. Become familiar with the specifications of the batteries that are installed by reading specifications and technical information provided by the manufacturers of any additional and/or replacement batteries you purchase. Please be advised that if you install Lithium batteries that the WFCO Power Center charges them to 90 percent capacity.

**WARNING: BATTERIES CAN CONTAIN SULFURIC ACID, WHICH IS HIGHLY CORROSIVE, FLAMMABLE AND EXTREMELY DANGEROUS. THUS, WE STRONGLY RECOMMEND THAT YOU HAVE ALL BATTERY MAINTENANCE, SERVICING AND INSTALLATION PERFORMED BY A QUALIFIED TECHNICIAN.**

The battery and charging system are the heart of the 12-volt DC system. Thus, it is important that you keep the battery fully charged and monitor its charge state. Low battery charge and/or bad batteries are common causes of poor appliance and other component part performance. Fuses and circuit breakers can fail even without a short circuit under low voltage.

The converter/charger system in your Cricket will help you manage your electrical requirements and charging needs. The converter/charger monitors and charges your batteries as needed when connected to a power supply. Please refer to the manufacturer's information regarding the converter/charger for more information. This is supplied with your habitat. Please also refer to the "Electrical System" chapter herein.



WFCO power center

(right front of kitchen in CAMP and TREK models)

There is a 12v monitor in the foot area of the Vberth, near the 12v accessory outlets. This will let you monitor current or charging voltages.



Your habitat will generally be in one (1) of the following three (3) power states when in use: (1) *dry camping (not connected to shore power)* ... you will be using battery power only to operate lights, fans and other DC components, and thus, discharging the batteries. Exercise constant vigilance in keeping your battery charged when dry camping. Make every reasonable effort to conserve your battery power (i.e. turn off lights and appliances when not being used);

(2) *being towed* ... if your tow vehicle has been wired properly, your habitat's battery will charge while being towed (the rate of charge varies



depending on the tow vehicle); and

*(3) connected to shore power ...* when you are connected to shore power (an external 120V power source), all batteries will charge automatically and will be regulated by your converter/charger so they don't overcharge. This is the fastest method of recharging your habitat. Connect to shore power through the marked 15 amp electrical inlet located on the rear driver's side of your habitat. Note: when parking the habitat for more than a few days, detach from tow vehicle, turn off appliances and lights, and plug in to shore power if available to ensure the battery is charged in advance of next use.

4. Connected to solar panels when off the grid. Crickets are prewired to accept specific solar panels (via the inlet at the rear driver's side of the habitat, or on the driver's side exterior). The rate of charge will vary based on the panels and solar exposure. PLEASE REFER TO SPECIFIC MAKES OF SOLAR PANELS ACCEPTED BY THIS SOLAR POWER INLET ON THE STICKER LOCATED NEAR THIS INLET.

*installation ...* proper battery installation is critical. Thus, please see a qualified technician for the installation and/or replacement of your habitat batteries.

*inspection and monitoring . . .* we recommend that you inspect and monitor the charge of the battery at least once a month and prior to any trip. During your inspection, look for cracks in the cover and case, and check vent plugs. *Have a qualified technician replace any cracked or broken plugs or other such items, and confirm that the hold-down hardware is tightly secured, that the battery box, tray or compartment is clean and free of corrosion, and that the vent caps and terminals are secure and tight.* Note: Do not store anything in the habitat battery compartment, box or tray other than the battery and its various components.

*charging and storing ...* keep the batteries fully charged but be sure not to overcharge the battery. If the habitat is charging via a power cord, shore power, your power distribution center will prevent overcharging. To check or monitor the battery charge, insert the readout accessory into any 12V outlet on the Cricket.

Here are three ways to charge your battery:

1. Plug into any 120V outlet via the inlet located on the rear driver's side of your Cricket.
2. Plug the habitat's 7-pin connector into an appropriately wired tow vehicle while the vehicle's engine is running.
3. Plug compatible solar panels into the inlet located on the rear driver's side of your Cricket

WHEN CAMPING, DETACH 7-PIN CONNECTOR FROM TOW VEHICLE. OTHERWISE IT IS POSSIBLE THAT THE HABITAT MAY DRAIN THE TOW VEHICLE'S BATTERY.

WHEN HABITAT IS IN STORAGE, MAINTAIN THE BATTERY BY PLUGGING A 120V POWER SOURCE INTO THE CRICKET'S ELECTRICAL INLET (LOCATED AT THE REAR DRIVER'S SIDE). THE CHARGE CONTROLLER WILL MAINTAIN A PROPER CHARGE WITHOUT OVERCHARGING.

OR

USE THE BATTERY CUT OFF SWITCH LOCATED ON THE CORE THE VBERTH CABINERY TO DISCONNECT BATTERY.

*dead batteries ....* If your battery is dead, plug into shore power if available. Reduce the loads on the battery by turning off any lights, 12-volt DC powered equipment and all non-essential items to allow rapid recharge. You may also connect the 7-way connector to your tow vehicle and run the engine at high idle to increase charging current and possibly reduce charging time. If your tow vehicle battery is dead or discharged, an external jumper battery or battery charger must be used to either start your tow vehicle engine, or generator, if any.

## APPLIANCES AND FIRE EXTINGUISHER

The following appliances are *optional*. If you choose to equip your habitat with any options, *please be sure to read and follow the separate manuals and instructions regarding safety, risks, use, maintenance, care and service associated with each option, add-on, appliance and/or equipment.*

*air conditioner* .... the air conditioner unit (AC), if any, will plug into an appropriately rated power outlet, and is not compatible with your Cricket's battery system. Remember that your air conditioner's performance depends largely on the heat levels/stresses on your habitat. Habitat heat stresses may be reduced as follows:

- Park in a shaded area
- Keep blinds down and closed
- Keep windows and doors closed, allowing the habitat to cool efficiently
- If you have an awning, use it to protect habitat from direct sunlight
  - Try to avoid using heat-producing items inside habitat
  - Turn on the AC unit early in the morning
  - Maintain AC unit as instructed by manufacturer

*refrigerator* .... the refrigerator, if any, operates on the habitat's 12V battery system. Please refer to the applicable separate manufacturer instructions for care and operation.

### FIRE EXTINGUISHER and SMOKE DETECTOR and CARBON MONOXIDE DETECTOR

Your habitat includes a fire extinguisher, which is located in the front of the Cricket near the kitchen. Test and operate according to manufacturer instructions. Your habitat also includes a battery powered smoke detector and a separate carbon monoxide detector, which should be tested prior to and during each camping trip.

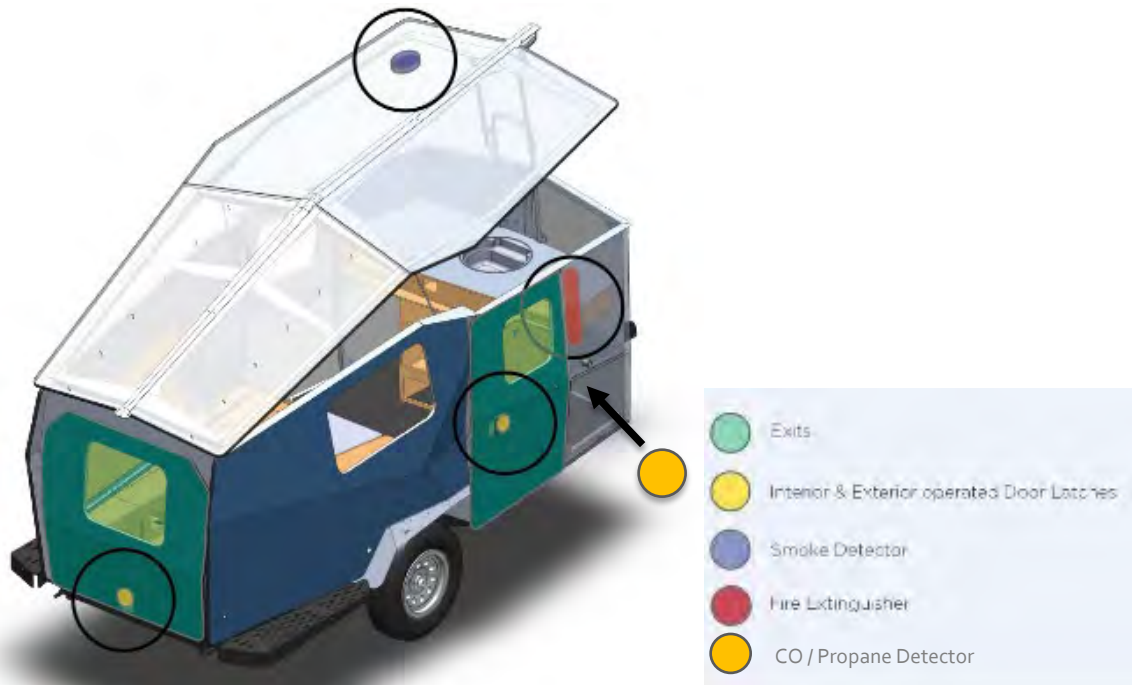



## PRE-TRAVEL CHECKLIST

### *interior ...*

- turn off all switches at kitchen switch panel.
- turn off and close all appliances, if not in use. You may keep the refrigerator on while driving.
- be sure your cargo berths are secured, and close and latch all windows
- be sure roof top is closed and latched properly at all three locations from inside and outside.
- be sure tent fabric is secured but not pinched.
- be sure shoreline power cord, 7-pin connector and hoses are secured (and properly attached, if applicable).
- close and lock all doors.
- be sure the stabilizer jacks and door step ladder are fully raised and secured.

### *exterior ...*

- check tire pressure and the tires generally for any punctures, cuts, and other problems.
- be sure wheel lug nuts are tight and secure.
- check that all tow vehicle and habitat lights and brakes are working in synchronization.
- check brakes with multiple applications in an empty parking lot.
- confirm brake controller, if any, is operating properly.
- be sure hitch assembly is secure, and that safety chains and breakaway switch have been properly attached.
- check underneath habitat for any damage or displacement.
- emptying water tanks prior to travel will decrease tow weight and improve fuel efficiency of your tow vehicle.

### **WARNING: DO NOT ALLOW ANYONE TO RIDE IN HABITAT WHILE IT IS BEING TOWED.**

Important Note: This is not an exhaustive list nor is it intended to be. Use common sense when preparing for a trip and all other helpful resources available to you.

### OTHER IMPORTANT PRE-TRAVEL CONSIDERATIONS

- be sure to pack wheel chocks and blocks.
- be sure roof rack cargo, if any, is secure.
- be sure to monitor your battery's charge before and during your trip. Charge battery before travelling, if necessary.
- tow vehicle ... read and follow the manual and all pertinent instructions provided to you by your tow vehicle manufacturer.
- be sure tow vehicle is operating fully before any trip, correcting any problems before travel.
- bring flashlight and batteries.
- make sure your cell phones are charged and that you have phone chargers.
- bring extension cords, if necessary.
- Take spare tire.
- check for any potential fire hazards, and eliminate them, if any.
- weigh your load before trip, making sure it does not exceed your GVWR.



## SITE SELECTION AND SET UP

With time and experience, you will get better at spotting and identifying good camping sites. Although they will vary to some degree, all good sites will (a) be level and (b) have a firm, not soft, ground that will support the weight of jacks and/or other support devices. There are also many public camping sites that provide electrical and other useful hook-ups or services. Once you have chosen your site, we suggest that you refer to the following important tips for your set-up:

*level and stable* .... (1) Before uncoupling, level the unit from side to side if desired with wood or plastic leveling blocks. Place the blocks on the ground forward of the wheels and tow the unit onto the blocks. Use wheel chocks to be sure the unit cannot roll;

(2) Lower the jack onto blocks or pad, if necessary;

(3) Use a habitat level to ensure habitat is level;

(4) Once the unit is level, use wheel chocks or blocks to prevent the habitat from moving;

(5) uncouple the habitat from the tow vehicle, unplug 7 pin connector from vehicle; and

(6) Lower the stabilizing jacks until they firmly engage. Be sure all jacks have about the same pressure on them.

Note: Before resuming travel, be sure that the stabilizer jacks are fully retracted/raised and that the habitat has been fully closed.

## OPERATION

**STEP 1.** Park RV on level ground, prevent wheels from rolling by using tire chocks.

**STEP 2.** Level trailer fore and aft using tongue jack or landing gear.

**STEP 3.** Check level gauge for low side of trailer, crank down stabilizers on low side first, bringing the trailer to a fine level position.

**STEP 4.** Crank down stabilizers on opposite side of

trailer to insure maximum stability. Then re-snug stabilizers on low side of trailer if necessary.

**NOTE - BEFORE MOVING TRAILER:** Crank up stabilizers to fully closed position and tighten 1/4 turn to secure in travel position (this prevents stabilizers from working open due to road vibration).

**MAINTENANCE:** Use small amounts of WD-40 or similar lubricant on drive screw threads and bolt locations as required.

**WARNING: DO NOT ATTEMPT TO USE JACKS STANDS OR STABILIZER JACKS TO JACK UP THE HABITAT OR SUPPORT THE FULL WEIGHT OF THE HABITAT. DO NOT ATTEMPT TO LEVEL, RAISE OR OTHERWISE PLACE ALL OF THE WEIGHT OF THE HABITAT ON THE STABILIZER JACKS. STABILIZER JACKS ARE NOT DESIGNED TO BEAR WEIGHT.**

*set-up cont.* ... once the unit is safely leveled and stabilized, continue with set-up:

(1) open roof (see below listed steps);

(2) connect to shore power, if available;

(3) connect to site water supply, if available, and

(4) set up the remaining features and/or options as needed.

OPENING ROOF .... follow these simple steps:

1. Unpin and unlatch the exterior safety latch located at the front and center of the habitat;

2. Enter the habitat and unlatch two (2) red-colored interior hold-down latches (located to the left of both the entry door and far-side window), both of which have a thumb catch.

3. Roof will raise somewhat from power of gas springs; and

4. While inside the unit, push the jointed brace (situated above the kitchen counter) until it locks in the "up" position (if fabric sides have yet to be installed, you can do this now.)

(see instructions for removing and installing tent side following)

CLOSING ROOF .... follow these simple steps:

1. While inside the habitat, pull the jointed brace (situated above the kitchen counter) toward you until it disengages (feels slightly loose), roof will remain slightly open supported by gas springs;

2. Pull down the roof using the brace and or the 'spine' of the habitat. This often means that one is sitting on top of the frig or on the Vberth seat by the time the roof is down. Pull the roof down just enough to loosely latch the J-bolts of the latches into their hasps. This will leave the roof not quite sealed closed but rather leaving 2 to 4 inches of space. **Do NOT secure the latches yet**

3. Exit the habitat now to make sure the tent side is tucked into the body of the habitat – the roof should seal onto grey fabric only! Tuck in loose flaps with your fingers. Make sure wooden toggles on tent side windows will not interfere with roof closure. At the same time you

perform this walkaround make sure that all jacks, hoses, cords, etc are safely detached and or stowed properly.



4. At the center front exterior push the exterior latch in place – push it until the pin is past the spring latch. Make sure that the roof is centered within guides. Some of you will be able to insert the clevis pin at this point. If it is too much wrestling wait on this til after step 5!



5. Enter the habitat and latch the side latches. Make sure the thumb catch is caught so that J-bolts cannot pop open!



You must roll tented side fabric (See (3) Below) first to ensure side latches do NOT catch and/or tear/cut fabric walls while latching. Be sure to carefully roll and tuck the fabric side walls into the unit when lowering the roof. Otherwise, the tented fabric is likely to catch on the roof's interior fastening clamps, causing rips and tears. Rips and tears and other damage caused by improperly closing the roof are excluded under the Taxa Inc. Limited Warranty. See "Limited Warranty" section herein.

**WARNING: BE SURE TO WATCH YOUR HANDS AND FINGERS WHEN SECURING LATCHES.**

#### INSTRUCTIONS TO TAKE OUT AND INSTALL A TENT SIDE .....

Your Cricket tent side is your friend. It keeps you dry in the rain and shaded from the sun. Sometimes a bird may poop on it, or maybe your daughter heaves a mud ball, it misses their brother and hits the tent side ..... (taking the tent off and spraying it with a hose usually takes care of these things). Sometimes, if not correctly installed, it can actually cause your Cricket to leak during storage. It goes on and off really easily. You should be comfortable in doing so. It only takes a few moments in either direction.

#### TAKING IT OFF:

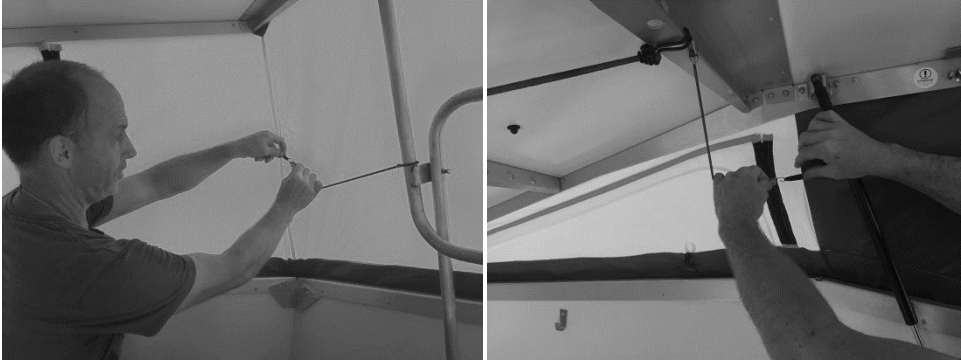

1. inside the habitat remove the 5 bungees that provide tension to the tent side. 3 are over the kitchen counter. 2 are at the mid-point of the tent side above the hold down latches.



2. outside the habitat, go to the rear of the habitat and grab the tail of the tent, pull that out perpendicular to the side of the habitat.



3. keep pulling the tent side off as you walk around the habitat, gather tent side in your arms as you go.

Done.

PUTTING IT ON:





1. Open your Cricket roof partially. Do NOT push that front bracket all the way up. Find the top center of your tent side. The grey edge is the bottom. Stand on the tongue, the toolbox or a step ladder.



2. Lay the two long trailing ends of the tent side on the kitchen counter on either side of the bracket. Take the center and press it to the Velcro along the top edge of the Cricket. Keep one hand at the center and run the Velcro out to the corner, pressing Velcro to Velcro. Repeat with other side.



4. Move to one side of the habitat and continue attaching the top edge of Velcro. Depending on your height you may want a step stool or to use one arm to lower the roof a bit more as you work to the rear. When you get to the tail you will need to use your fingers to shove the tent side in to adhere the Velcro. This is easier the lower the roof is. The very end of the tail should pull out the rear of the roof (just barely). Repeat on other side of habitat.



5. Go back to the front of the habitat, inside or out, and push the roof bracket all the way up. Find the center bottom of the tent side (there is a small slit in the grey there) and pull it down to either side of the guide in the lower skeleton.



6. Pull the tent side front down to minimize wrinkles and attach the lower Velcro edge to the corner. Repeat for other side.



7. Attach the lower Velcro from the front corner back to the door post. Pull down slightly to remove wrinkles. STOP. Attach the lower Velcro from the rear tail forward to a point just above the forward corner of the large window where the skeleton bumps out toward the door post. This leaves about one foot unattached.



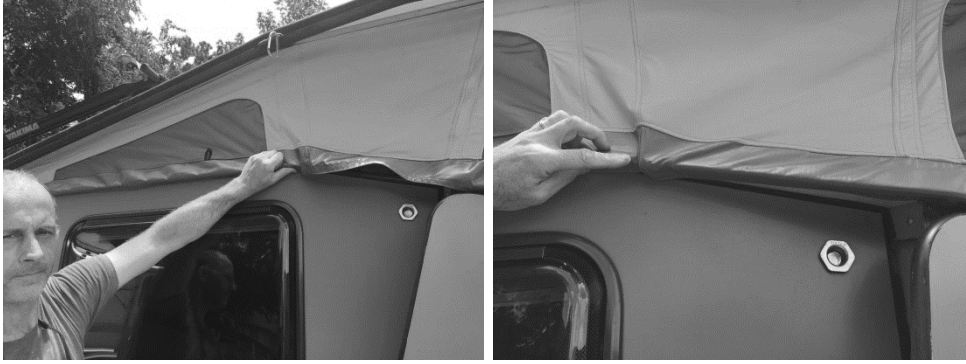

8. Attach this last foot or so from the front to the rear. There may or may not be a small fold that needs folding here (depends on model year and tent side). Make a rear facing fold in line with the seam in the tent side. Repeat on other side.



9. If latching the tent side down for driving or storage - pull down the roof and loosely catch the J-hook so that the roof is about 3 or 4 inches from being pulled all the way down. Exit the habitat.



10. Walk around the habitat and tuck in any orange fabric you might see. At every tent window location feel with your fingers to make sure the wooden toggle is inboard of the skeleton.

11. When at the front of the habitat pull down on the center handle and push latch past the spring catch.

12. Enter the habitat and lock the side latches. Avoid pinching the fabric in the latch by gently rolling the fabric in this area.

14. Insert safety pin in exterior front latch.  
Finished.

Troubleshooting:

If your Cricket leaks a bit during storage (generally noticed as a small balloon of water caught in the tent fabric over one or the other corner



of the kitchen counter), it is generally caused by one of the following issues:

- a. One of the window toggles (the thing that keeps the tent window rolled up) gets squished between the roof gasket and the bottom edge of the Cricket and cause a path for the water to seep in slowly. To avoid this check with your fingers to make sure those toggles are not caught between the weather seal and bottom edge of the Cricket as the roof is closed.
- b. Some other wrinkle in the forward side edges of the habitat is dribbling water. This is caused by either us at the factory installing the tent less than perfectly, or by a customer who has not pulled the tent side inboard before the roof gets latched down. To avoid this do one of the following:
  1. re-close the roof, with tent side pulled in more rigorously (do not go crazy! There will always be a few wrinkles but try to minimize them.)
  2. raise the Cricket roof, un-Velcro the lower edge and re-attach as per instructions below
- c. The clamps that latch down the roof down need some adjusting - with a wrench or pliers tighten the J-bolt on the inside of the habitat (do this after "a" and "b" above).

Suggestion:

If you are storing your habitat outside for some time between uses (over the winter, for a month or two), you can detach the lower Velcro of the tent side, tuck it into the inside of the habitat and latch the roof with the tent side hanging on the inside of the habitat. This removes any possibility of wrinkles AND further protects the grey fabric from getting discolored by UV light (that grey is UV treated but will discolor a bit over time).

### **Awning**

An awning or shade structure can be a very useful addition to your Cricket. Shelter from the sun, rain and bugs can be achieved with different styles.

Numerous attached awnings or shade structures can be used with a Cricket. TAXA has provided 3 attach points on the passenger side roof to which tarps can be tied off too. Freestanding shade structures can also be used.

### **Privacy Shelter**

A privacy shelter or cabana can be a very useful addition to a Cricket. These can be freestanding or, with some styles, tied off to the Cricket's front driver side or at the rear of the habitat. These private spots can be used for showering off, changing clothes or bathing suits or can be an outside the habitat spot for a porta potti. There are many models on the market.

Taxa recommends and sells the Kelty Blockhouse Shelter.



## VENTILATION

*overview* .... good ventilation and indoor air quality is essential to long-term enjoyment of your habitat. Inadequate ventilation can increase indoor pollutant levels. To maintain good air quality, be attentive to proper ventilation of your habitat, keep it clean, and prevent and avoid unnecessary air pollutants. Common indoor air pollution sources include molds, pollen, pet fur dander, secondhand smoke, carbon monoxide from burning propane and other fuels, and household cleaners.

Travel habitats are much smaller than homes. Thus, the exchange of air inside a travel habitat is significantly less than a home. Proper ventilation is an ongoing process, occurring before, during and after use, and at times when the temperatures and humidity are elevated. Decreasing the flow of air by sealing the travel habitat may increase the presence and/or concentration of indoor air pollutants, such as but not limited to, molds and household chemicals. Improve ventilation by opening windows, using fans and opening vents, running the air conditioner, or some combination thereof. We also recommend that you do not smoke or use any type of bug or other chemical spray inside your habitat.

**WARNING: Your habitat was designed for recreational use and short-term occupancy only. Long-term occupancy can create conditions, which if not managed properly, can be hazardous to your health and cause significant damage to your habitat.**

The following are three (3) basic strategies recommended by the Environmental Protection Agency (EPA) to improve indoor air quality:

(1) *remove sources* ... eliminate sources of pollution and/or reduce their emissions. Pollutants that this strategy can have an impact upon are: (i) Biological Contaminants such as bacteria, molds, mildew, viruses, animal dander, and pollen, (ii) Household Products such as paints, varnishes, cleaning and disinfecting solutions, cosmetics and hobby products, and (iii) Pesticides.

(2) *ventilation* ... increase the amount of outdoor air coming indoors. Typically, habitat air conditioners, for example, do not mechanically bring fresh air into the unit. Simultaneously opening doors and windows to allow fresh air in along with turning on fans to take inside air out is an effective way to improve ventilation. Remember, if there is insufficient outdoor air entering a habitat, pollutants may accumulate to higher levels.

(3) *air cleaners* ... air cleaners are designed to remove particles from the air. There are many types and sizes of air cleaners available to you on the market. Note: Air cleaners are not generally designed to remove gaseous pollutants. The effectiveness of an air cleaner depends on how well it collects pollutants from indoor air and how much air it draws through the cleaning or filtering element. For more information about Ventilation, Indoor Air Quality and its effects, please refer to [www.epa.gov/iaq](http://www.epa.gov/iaq).

## MOISTURE/CONDENSATION

The relatively small volume and compact construction of travel habitats means that the normal activities of even a few persons can lead to rapid, visible moisture saturation in the habitat, especially in cold weather. Note: some estimates indicate that a family of four can vaporize up to three gallons of water through daily breathing, cooking, bathing and washing. Just as the moisture collects on the outside of a glass of cold water during humid weather, moisture will condense on the inside surfaces of the habitat during cold weather when the relative humidity of the inside air is high. Unless water vapor is carried outside, it will condense on the inside of the windows and walls. Thus, when you observe signs of excessive moisture and condensation in the habitat, take action to minimize the effects. Such action steps *in non-extreme hot or cold weather conditions* may include but not be limited to the following: Allow excess moisture to escape by ventilating with outside air. Open windows to provide circulation of outside, dryer air to the inside. While this ventilation may increase the heating load during cold weather, it will greatly reduce water condensation.

Minimize moisture released inside the habitat such as steam from excessive boiling water or other use of hot water. Remove water or snow from shoes before entering the habitat. Avoid drying wet or damp clothing, towels, gear and other items inside the habitat.

Manage the inside temperature during cold weather. Remember that the higher the temperature inside (in cold weather) will cause condensation to form on areas that are not insulated as well as others (windows, vents, wall studs, etc.); try to avoid drastic, quick temperature reductions, which can increase moisture condensation inside.

Properly maintain and secure the exterior of the habitat. This will help keep a tight barrier against water intrusion. Note: using your habitat in severe climates or weather conditions (which is NOT recommended ... see "severe weather use" section), such as extreme hot, humid or cold weather, will require extra care, attention and maintenance of moisture-related issues and relative humidity conditions inside the habitat.



#### *Other tips to minimize condensation*

When, for example, washing dishes, hair drying, laundering, cooking and using appliances and non-vented gas burners, keep a window partially or fully open turn on your fan, if any; Keep all doors and vents open when practicable; Allow air to circulate inside cabinets (leave doors partially open) so the temperature inside the cabinet is the same as in the rest of the unit. Clean any spills immediately.

On laminated surfaces and the floor (use mold or mildew-killing cleaning products. Check sealants regularly and reseal when necessary to avoid water leaks. Use LED, or fluorescent lights and minimize prolonged use of incandescent lights, which produce heat and may contribute to condensation issues.

Remember ... your natural tendency may be to close the habitat tightly during cold weather. This will actually make any moisture/condensation problems worse. You need to ventilate the habitat, allowing inside air to travel outside.

Note: If the tips outlined here are not effective in controlling condensation, it may be necessary for you to invest in a dehumidifier to reduce the health risk to you or your family as well as prevent damage to your habitat.

#### **MOLD**

Molds are pollutants found in virtually every environment. Left unchecked, molds break down various materials such as wood products and fabrics. Mold can rapidly grow indoors if it is warm and humid. By controlling relative humidity (moisture) as outlined herein, the growth and potential for growth of mold and mildew can be greatly reduced.

#### **Additional Web Resources**

We also recommend that you visit the following web sites which maintain information about indoor air pollutants, including molds and formaldehyde, along with ways to improve indoor air quality:

<http://www.epa.gov/iaq/pubs/insidest.html>

<http://www.atsdr.cdc.gov/tfacts111.html>

<http://www.epa.gov/iaq/molds/moldguide.html>

<http://www.formaldehyde.org/>

<http://rvia.org/> (Recreational Vehicle Industry Association's Web site – Under the Technical Information

**WARNING: Taxa Inc. carefully chooses the production/manufacturing materials for its habitats. However, Taxa Inc. does not warrant or otherwise represent that its production/manufacturing materials are formaldehyde free.**



## FOUR SEASON USE / EXTREME WEATHER

Your habitat was NOT designed for use in extreme climates or weather situations. It was designed to be used any season you wish. Some conditions require special consideration or preparations.

**If conditions are extreme due to weather or other natural or unnatural causes BE SAFE!  
Get yourselves to safety. Get your vehicles to safety as a secondary concern.**

Your habitat was designed for short-term use (typically seven days or less) in normal, moderate temperature and climate conditions. Normal, moderate temperatures are between 32 degrees F and 100 degrees F. Climates falling outside of this range are considered extreme for purposes of this manual and your habitat. Be advised that some of your habitat's systems and components are not appropriate for use in extreme climates (see further notes below). Please be advised that some damages, losses or injury arising out of use of your habitat in extreme climate conditions may not be covered under the Limited Warranty. See Limited Warranty section herein. **Thus, before you consider using your habitat in extreme conditions, please read the following:**

*plumbing system* ... your habitat's fresh and waste water plumbing will require preparation and or attention during extreme cold weather use. The interior plumbing can be kept from freezing either by use of your furnace OR by draining all lines and traps. The fresh water and Grey water tanks are exterior and not insulated. Freezing temperatures can cause extensive damage to the plumbing system, resulting in costly repairs or replacement not covered under your Limited Warranty. Your plumbing system and components should not be used in below freezing conditions. Remember that no portion of the plumbing system is situated in a heated compartment, and much of it is directly exposed to the outdoor air and especially susceptible to freezing. Thus, be sure to take notice of where all plumbing is situated on your habitat. You can comfortably camp in winter! However, your drinking water should come from portable water containers that you can keep unfrozen or do not care if they freeze. Please also refer to the "Plumbing System" section.

*insulation and heat* .. keep the inside of the habitat heated and insulated. Use your furnace that is integrated into the habitat to keep interior temperatures modulated. Follow all manufacturer's instructions for safety.

The panels of your habitat are insulated. You may consider installing heat tape or similar underneath the habitat and around exterior plumbing components. If applicable, wrap the fresh water inlet plumbing and waste lines with heat tape. Be sure to follow all use and installation instructions provided by your heat tape, etc. manufacturers. Periodically check the habitat systems and components.

*additional tips* .... thoroughly dry, thaw out and drain water from hoses before storing, and drain holding tanks if possible. This should reduce the likelihood of damage to your tanks from a freeze. Supply your habitat with bottled water for drinking, cooking, washing and brushing your teeth. You may also consider winterizing your habitat. See "Winterization" section herein.

*battery and electrical systems* ... If you are connected to shore power or have a generator, you should have all the power you need to operate appliances. You can easily run your furnace or, if with shore power, can plug in a portable electric heater. However, if you are dry camping (i.e. no shore power or generator), your battery or batteries will be your only source of power, and thus, your primary electrical system concern in extreme cold. Be sure to keep the battery charged and conserve available energy when possible. *Remember that there is no substitute for common sense when camping in extreme weather conditions.* Please also refer to the "Battery" and "Electrical System" sections herein.

### EXTREME HEAT and COLD

Please use common sense when camping. Extreme heat and extreme cold can cause injury and or death, especially to the elderly and young. Take all necessary precautions when camping.

Here are some notes for camping in:

#### WINTER:

- bring bottled water for drinking, washing, brushing teeth etc. Keep those plumbing lines and tanks free from water in prolonged freezing conditions.
- your furnace will keep you warm and toasty even with the roof up. We have been to well below freezing in our experiences.
- have a good sleeping bag, zip two together
- some people close the roof at night for extra insulation



**SPRING:**

- no special considerations unless you are up high or far north where temps may drop below zero at night.

**SUMMER:**

- your habitats roof is insulated! on the hottest of days being inside is like being on a porch – shady and with great cross-ventilation. Have a siesta in the middle of the afternoon and stay up late!
- get a clip on 12v fan or two!
- some climates support swamp cooler use.
- (some need an AC)

**FALL:**

- no special considerations unless you are up high or far north where temps may drop below zero at night.





## GENERAL CARE AND MAINTENANCE

Regular care & maintenance of your habitat is important in furthering safety and dependability. Keep good records of all service and maintenance performed on your Cricket. These records may be necessary for limited warranty purposes or may assist in future repairs. Always refer to the manufacturers' care and maintenance recommendations for installed appliances.

*exterior finish* ... your habitat's exterior is made of painted aluminum composite panels, which are durable and easy to maintain. Aluminum is lightweight and relatively soft, naturally showing wear over time. Cosmetic marks are intrinsic to aluminum and do not constitute a fault in material or defect in workmanship. Routine maintenance is the best way to minimize and guard against cosmetic changes due to weathering. Wash the habitat exterior with a soft cloth, warm water and soap thoroughly, paying special attention to the graphics. Never use strong solvents or abrasives when cleaning. Also, be aware that power buffers and high pressure washers may damage or totally remove the graphics. See also the following summary of do's and don'ts:

Do use soft cloths to clean  
Do be careful around graphics, washing with the graphics, not against them.  
Do not use products containing ammonia or caustic, harsh cleaning agents.  
Do not use high-pressure washers, rotating brushes (i.e. in-car wash facilities), or power buffers.  
Do not dry wipe surfaces  
Do not use rubbing compounds.

*frame and chassis* .... Over time, various weather and climate conditions may lead to corrosion your habitat frame and chassis. Be sure to rinse the habitat undercarriage, wheel wells, hitch and bumper of all dirt, oil, tar, salt and other debris periodically and as needed. Remember to routinely inspect for evidence of rust. Do so frequently when camping in or near coastal regions.

*hitch couplers* ... Inspect hitch couplers before each trip. Clean and lubricate the ball socket and clamp monthly using wheel bearing grease. If hitch assembly and coupler appears damaged in any way, contact your dealer and resolve the problem before travel.

*safety chains* ... Inspect safety chains before each trip. Replace them before travelling if they are damaged or compromised in any way.

*jack* ... Inspect and test the jack before each trip. Clean and lightly apply oil periodically and as needed. If your jack needs repair or other service, see a qualified technician.

*tires and wheels* ... inspect your habitat tires, checking air pressure regularly and before each trip. Keep them inflated to recommended pressure, which is located on the tire sidewall. Keep a tire gauge in your tow vehicle or habitat. Have the tires rotated by a qualified technician at least every 5,000 miles.

*brake adjustment* ... have your habitat's electric brakes adjusted after the first 200 miles. Have them tested for brake drag every 3 months or 3000 miles, whichever is earlier. When adjusting brakes on any vehicle, either replace or adjust all brakes at the same time, or at least both brakes on the same axle. Qualified service personnel should perform all required work on brakes.

*sealants* ... Inspect all sealants/seals (i.e. doors, windows, plumbing components, undercarriage) every ninety (90) days, when the seasons change, and before each trip. During your inspection, look for cracks, voids, shrinkage, and any other sign of deterioration. Replace sealant where necessary, using the same type of sealant. Contact your dealer or Taxa Inc. for suggestions concerning replacement sealants.

*tent sides* ... you may clean your habitat tent sides periodically with warm soap and water and then dry. The tent sides are made out of waterproof, flame retardant, breathable, Ultra-violet treated, high-performance material. While very durable, no fabric lasts forever. The best storage procedure, if the habitat is stored out of doors, is to park it under the cover of a roof, habitat, cover or tarp. Keep your tent sides dry when possible to avoid prolonged exposure to mildew, which may damage them. If you have mildew, use the following recipe:

*Mix 1 cup of salt, 1 cup of lemon juice, and 1 gallon of hot water  
Wash moldy/mildew areas of the tent with a sponge  
Let dry*

Be aware that wind, water, sun, pollution, debris and neglect may all degrade your tent side fabric over time. Have the tent side



repaired at the first sign of fraying or tearing. Take care to protect the fabric from metal parts.

*ceiling, interior walls, countertop and table ...* clean with soap or other mild, non-abrasive cleaner, warm water, and a damp cloth. Do NOT use strong, harsh chemicals, and limit water/moisture exposure to ceiling and walls when cleaning. Excessive moisture may damage ceiling and walls. Be sure thoroughly dry ceiling and walls after cleaning. Avoid using abrasive pads and scouring powders, which may dull surfaces and increase exposure to future staining.

Remember to use a chopping block or cutting board when using knives on the countertop. Pots and pans straight from the burner or oven should be placed on lined hot pads and not directly on the counter surface.

*faucets and fixtures ...* use only a damp soft cloth or sponge to clean. Do not use abrasive cleaners or materials as they may damage the finish.

*fabric and upholstery ...* Berth cushions are made of a fixed marine-grade vinyl. Clean them with a damp cloth and mild soap or other cleaning product. Be sure to dry thoroughly after cleaning. Folding couch cushions are made of nylon which may be machine washed cold and air dried.



## STORAGE, WINTERIZATION & BRINGING OUT OF STORAGE

If storing your habitat in persistently cold weather (less than 20 degrees F), you must prepare your habitat appropriately. We recommend that you store your habitat in a dry, level, well-ventilated area protected from the elements. Use blocks, chocks or ramps for the wheels, if necessary. A garage is ideal. Refer to and follow the following storage preparation guidelines:

### *interior ...*

- Open your refrigerator, if any, and remove all food items, block lid open to provide air movement
- Spread out your upholstery so that air can reach all sides
- Open all cabinet doors and drawers, including interior storage area
- Place containers of moisture-gathering beads in the habitat
- Clean the floor, walls and all surfaces

### *chassis ...*

Lubricate all grease fittings on the axle hubs  
Check all tires for damage and set tire pressure to the maximum as indicated on the tire sidewall. Clean the tires and wheels with your regular soap/car wash solution  
Clean the tires and wheels as well as the underside of the habitat. Wash off mud and/or other road accumulations on frame, axles, and other components. Inspect and make note of damage to or in any areas or components.

### *exterior ...*

Close all vents and windows and thoroughly wash the exterior, including roof, sidewalls and front and rear.  
Note any maintenance issues that arise that may be needed. Inspect the sealants around roof accessories (vents, racks, etc.), windows and doors, resealing as necessary before winter rains or snows accumulate (to prevent leaks when snow melts in spring)  
Cover all exterior appliance vents.  
Extend the awning (if equipped). Vacuum or sweep away branches, leaves, and any other debris. Wash with a mild, natural soap to reduce mildew. Allow to dry completely before retracting the awning.  
Be sure all exterior components, attachments, etc. (breakaway switch, cords, safety chains) are secured

Prevent habitat from rolling unexpectedly during storage - chock wheels, raise levelling jacks and retract step assembly.

*plumbing system ...* proper preparation and winterization of your habitat fresh water and waste water systems are **vital**. Freezing water expands, leading to possible rupture of tubing, fittings, tanks, and fixtures. Thus, be sure to empty the holding tanks before storing and winterizing. Drain hot water or fill traps and lines of system with non-toxic anti-freeze if you are unable to blow out any pockets of water with pressurized air. Turn off the water heater, if any, and let it cool. Remove access panel and remove HW distribution line per instructions in section PLUMBING SYSTEM. Siphon water from tank per same instructions. Reinstall HW line by firmly pushing it back into place.

Open your sink and shower faucets, both hot and cold,  
Open the drain valves of both the gray and potable water tanks, and fully drain the tanks . Close the valves when tanks are completely drained /empty  
Disconnect the shower hose and drain the hose.  
Drain your TRUMA furnace and hot water heater per manufacturer's instructions.

**IMPORTANT NOTE: ALL FRESH WATER LINES MUST BE FLUSHED WITH FRESH WATER TO CLEAR THE FRESH WATER SYSTEM OF ANY ANTIFREEZE PRIOR TO USING FRESH WATER SYSTEM AFTER STORAGE**

*electrical system ...* preparation and winterization of the electrical system primarily revolves around your battery. Proper battery storage helps ensure both the powering up of your habitat systems on your next trip, and maximizing the life of your battery. Refer to the "Battery" section of this manual for proper storage information. Important Note: remember to turn off all electric loads in your habitat prior to storage.

### BRINGING OUT OF STORAGE

If your habitat was properly and carefully stored and winterized, taking it out of storage and prepping it for another travel season should be relatively simple. Note: if your habitat sustained damage while being stored, please consult with your dealer or Taxa Inc. for information regarding repair or service options. The following checklist assumes that you stored your habitat with care:

Thoroughly inspect the habitat exterior, looking for animal nests in, for example, wheel wells, compartments or openings.

- Open all doors and compartments, checking for animal or insect intrusion, water damage, or other deterioration
- Check charge level in all batteries and recharge as needed.
- Check tire pressures and re-inflate to specified cold pressure
- Lube chassis
- Check all exterior lights, and replace as needed
- Drain, flush and sanitize the fresh water system as outlined in the General Care and Maintenance chapter.
- Inspect the drain hose for leaks and replace it if necessary
- Turn on sink faucets and all plumbing fixtures (faucets, water pump, Hot Water Heater), checking all joints and fittings and repairing leaks, if any.
- Check all 12-volt DC circuit fuses
- Operate all 12-volt DC lights and equipment
- Test the carbon monoxide detector as manufacturer's instructions (if equipped).
- Check your shore-line power cord, 7-pin connector, converter, all outlets, breakaway switch, and any exposed wiring. If defects are found, refer service to your dealer
- Operate air conditioning system (if equipped)
- Inspect and clean the interior
- Check sealants on and around the roof, body seams and windows, resealing as needed.
- Wash the exterior, thoroughly flushing the habitat underside.

## TROUBLESHOOTING

### Plumbing

Description	Likely cause	Fix
Sink backed up	Gray water tank full	a. open gray water valve to drain
	Sink Trap clogged	Remove kitchen access panels to access plumbing (secured with three bolts). Squeeze or remove trap to loosen clog.
Sink leak	Loose connection	Inspect sink drain, p-trap, and drain hose, tighten where necessary
Shower leak – Exterior	Loose connection, sand / grit in quick disconnect	Flush out exterior quick disconnect with water to remove grit
Shower drain leak	Loose connection	remove access panel below shower, visually inspect and tighten connections.
Plumbing leaks behind kitchen cabinetry	Loose connection	Pressurize system, observe leak spot. Tighten hose clamps and or push pull fittings.
Plumbing leaks under habitat	Loose connection	Check plumbing connections in problem area and tighten if loose
Water heater leak	loose connection or over pressured water.	Check push pull connectors at heater (push and pull them to check if one is loose!) at heater. Remove and re-insert. Ensure city water is below 125PSI and is being regulated by pressure regulator at inlet.
Low water pressure	Drawing air in water supply line	Tighten line by checking connections back to water tank from sink; tighten or re-connect. Check connection also beneath habitat. Sometimes you can

		hear air entering line when water pump is turned on.
Fresh tank won't fill	Hose improperly inserted	Use fill line connector
	Vent blocked up or crimped	Blow out vent line (small hole just above fill area) If crimped, remove bend in line. (accessible by removing service panel beneath Vberth)
Water pump not working	Check fuse beneath water pump switch at kitchen.	
		Replace pump
Water heater not working	no hot water	Verify that furnace (heat) is working. Check LCD control panel to make sure setting is correct, not on a timer that timed out. Check top of furnace unit itself to verify that small switch is in ON position. Note that water heating speed depends on inlet temp.
	no power (no LEDs on unit)	Check fuse on switch plate at kitchen.
	if propane	Check GFCI breaker where heater plugs into outlet beneath cabinet. Reset.  check TRUMA manual troubleshooting
	if propane	check propane supply and valves

Electrical

Description	Possible cause	Fix
120v circuit breaker pops	Wet extension cord	Dry cord, reset breaker.
Battery not charging (see LED volt monitor: - a well charged battery is between 12.6 and 12.8V - a charging battery is ~13.4V if habitat is plugged in to 120v - + ~.2V if solar or vehicle charging)	7-pin connection short	Check tow hitch connection and wiring. Verify that interior volt meter jumps up in voltage when car is turned on and 7 pin is in position. Check for loose or burnt wires in connector.
		Check habitat end connection
	Converter/charger	Test converter charger; replace converter element if necessary
		Check 30 amp fuses at WFCO
	Battery charge	Test battery



Circuit interruption	Overloaded circuit	Throw circuit breakers or replace fuses.
Lights flickering	Battery not charged	Check battery charge
Frig not functioning	Battery not charged	Check battery charge
	Blown fuse in frig plug	Check inline fuse in frig plug (green LED should be on in plug when functioning)
	Blown fuse in WFCO	Check fuse position #4
	check ON/ OFF LEDs	inside of frig, top left are on/off and temp settings
Ceiling lights not functioning	Blown fuse in WFCO	Check fuse # 2
Kitchen 12v outlet not functioning	Blown fuse in WFCO	Check fuse #3
Exterior 12v outlet not functioning	Blown fuse in WFCO	Check fuse #1
Kitchen counter lights not working	popped circuit	Check glass fuse beneath switch
Red step light not functioning	popped circuit	Check glass fuse beneath switch
Hot Water Heater not turning on	popped circuit	Check glass fuse beneath switch
Water pump not turning on	popped circuit	Check glass fuse beneath switch

#### Exterior leaks

Description	Possible cause	Fix
Roof leak	Roof latch loose	Adjust interior roof latches, tent side, ensure fabric and window toggles are preventing best seal
	damaged weatherseal	inspect, replace if required
Leak through tent side	Tent side not installed properly. Tent window open during rain.	Reinstall tent side (see SITE SELECTION AND SETUP)

#### Doors, windows, tent sides and graphics

Description	Possible cause	Fix
Side door gap	Missing/misaligned door gasket	Install door gasket
Key will not turn in cylinder	dirt or grit	Lubricant such as WD40
Window will not close	dirt or grit	Lift window to full open position. It should now go all the way down. Repeat if required
Window gap	adjust latches	interior latches have two locked positions, one closes to weather and dust, other leaves 1/8" gap
Broken window arm	Misuse	Install new part by pressing pin hole, removing broken arm, and replacing



## LIST OF AUTHORIZED DEALERS

Our dealers and their contact information are subject to change. Please refer to our website [www.taxaoutdoors.com](http://www.taxaoutdoors.com) for updated dealer and contact information lists.



## your Cricket LIMITED WARRANTY

We want you to enjoy your Cricket without problems. As the owner, you are responsible for regular care and proper maintenance of your Cricket. Proper use, care, and maintenance will help avoid situations under which the Limited Warranty will not cover items due to neglect or misuse. Maintenance should be performed in accordance with this manual as well as the corresponding component manufacturer's manuals included within your habitat. If you have any questions at all regarding proper care or maintenance, please contact your dealer or Taxa Inc.

This limited warranty gives you specific legal rights. You may also have additional legal rights, which vary from state to state. Taxa Inc.'s warranty obligations are limited to the terms set forth herein and applicable law. Any additional statements concerning this limited warranty not included herein, whether oral or written, are not the responsibility of Taxa Inc. and should not be relied upon you. Please contact us if you have any questions regarding the following limited warranty.

### LIMITED WARRANTY COVERAGE

#### *Coverage - Plumbing and Electrical Systems*

Defects in material and workmanship in the plumbing and electrical systems as originally installed by Taxa Inc. only. The duration of this Limited Warranty for the plumbing and electrical systems is for a period of one (1) year, beginning on the date of purchase by the original owner/purchaser and ending one (1) year from such date.

#### *Coverage – Structural*

Defects in material and workmanship in the structure of your habitat as originally installed by Taxa Inc. only. The duration of this Limited Warranty for the structure is for a period of two (2) years, beginning on the date of purchase by the original owner/purchaser and ending two (2) years from such date. The structure includes only the frame, wall framing, floor framing and their connection to each other. It does not include attachments to the structure. Attachments include but are not limited to the following: axles, tented sides, stabilizer jacks, steps, couplers, vents, windows, shades, roof tracks, roof racks, appliances, add-ons, accessories, component parts, air conditioning unit, and refrigerator.

Taxa Inc. will, in its sole discretion, repair or replace, as necessary, the covered material or workmanship, at no cost to you and within industry standards. Taxa Inc. will also, in its sole discretion, use the same, substantially similar, new, remanufactured, refurbished, and/or reconditioned components, parts, materials and/or systems in fulfilling its obligations under this Limited Warranty. Taxa Inc., in its sole discretion, shall determine whether the dealer, service center, or other authorized facility is the appropriate location to perform the covered warranty repairs or replacement, if any. You shall be responsible for delivering the habitat to the dealer, service center or other facility designated by Taxa Inc. for such covered repairs or replacement, if any.

After a repair is performed, inspect it thoroughly. Go over the repairs with the dealer and/or service center representative. Upon your satisfaction, sign the repair order. In the event a problem should reoccur after you have left the dealer or other authorized facility, contact the dealer or Taxa Inc. as soon as possible so that the situation can be resolved quickly.

#### Owner's Responsibilities

Your responsibilities include: (1) carefully reviewing and following the information and instructions contained within this manual and all supplied component manuals; (2) proper care, use and maintenance of your habitat as outlined by this manual and all supplied component manuals; and (3) returning your habitat to an authorized dealer, service center or other facility authorized by Taxa Inc. to perform any necessary, covered warranty repairs, service or replacement.

#### WHO IS COVERED BY THIS LIMITED WARRANTY

Only the original purchaser/owner of the unit is covered under this Limited Warranty. This Limited Warranty is not transferable and does not cover subsequent purchasers/owners of the unit.

#### HOW TO PROPERLY SEEK A REMEDY UNDER THIS LIMITED WARRANTY

(1) Written or electronic notice of your warranty claim or claimed defects along with (2) your dated receipt as proof of purchase must be given either to the selling dealer or Taxa Inc. not later than ten (10) days after the expiration of the applicable limited warranty duration period as defined herein. Otherwise, your warranty claim will be considered untimely. Failure to timely notify of a warranty claim will void this limited warranty.

If your dealer is unable to resolve your warranty claim or you would like to first notify us of your warranty claim, please contact us as follows:



Taxa Inc., 1830 West 15<sup>th</sup> Street, Houston TX 77008, Tel: 713.861.2540, and Email: [hello@taxaoutdoors.com](mailto:hello@taxaoutdoors.com). Please also visit our website [www.taxaoutdoors.com](http://www.taxaoutdoors.com) for any updated contact information.

#### **SOLE AND EXCLUSIVE REMEDY**

**TO THE MAXIMUM EXTENT PERMITTED BY LAW, THIS LIMITED WARRANTY AND THE REMEDY EXPLAINED HEREIN ARE EXCLUSIVE AND IN LIEU OF ALL OTHER WARRANTIES, REMEDIES AND CONDITIONS, WHETHER ORAL OR WRITTEN, EXPRESS OR IMPLIED. TO THE MAXIMUM EXTENT PERMITTED BY LAW, TAXA INC. SPECIFICALLY DISCLAIMS ANY AND ALL IMPLIED WARRANTIES, INCLUDING WITHOUT LIMITATION, WARRANTIES OF MERCHANTABILITY AND FITNESS FOR A PARTICULAR PURPOSE. THE FOREGOING DISCLAIMER OF IMPLIED WARRANTIES SHALL NOT APPLY TO YOU OR THE HABITAT IF SUCH DISCLAIMER IS IMPERMISSIBLE UNDER APPLICABLE LAW.**

#### **WHAT IS NOT COVERED UNDER THIS LIMITED WARRANTY/EXCLUSIONS**

This limited warranty does not cover any damage, loss, deterioration or malfunction resulting from any alteration, modification, improper or unreasonable use or maintenance, misuse, abuse, tampering, accident, neglect, exposure to excess moisture, fire, lightning, power surges, and/or acts of nature or God. This limited warranty does not cover any damage, loss, deterioration or malfunction resulting from any repairs attempted by anyone unauthorized by Taxa Inc. to make such repairs, or any other cause which does not relate directly to a defect in materials and/or the workmanship of this unit.

Without limiting any other exclusion herein, Taxa Inc. shall not be liable for any incidental or consequential damages, including but not limited to travel, transportation, and lodging expenses, loss or damage to personal property, loss of use, inconvenience or loss of income whenever allowable under state law. Damages for any failure to successfully repair or replace any defect in accordance with this limited warranty shall be limited to the reasonable cost of such repair or replacement as of the time of the alleged failure or defect. This exclusion of consequential and incidental damages shall be deemed independent of, and shall survive, any failure of the essential purpose of this limited warranty.

THE FOLLOWING NUMBERED LIST (1 THROUGH 24) IS NOT EXHAUSTIVE AND DOES NOT LIMIT ANY OTHER EXCLUSION OR LIMITATION DISCUSSED HEREIN OR PERMITTED BY APPLICABLE LAW. THIS LIMITED WARRANTY SHALL NOT COVER NOR APPLY TO:

- (1) Items not manufactured, installed or sold by Taxa Inc., whether warranted separately or not by their respective manufacturers, including but not limited to, tires, batteries, fuses, ac units, heaters, refrigerators, porta-potty's, roof racks, generators, structural and other modifications, and all other such equipment, products, accessories, components, parts, add-ons, appliances, and attachments;
- (2) Habitats used for and/or damage or loss arising from business, rental, commercial, residential, or disaster relief purposes/uses, and/or any non-recreational purpose/use;
- (3) Habitats not originally sold through an authorized Taxa Inc. dealer;
- (4) Habitats sold through auction, repossession, salvage or in an otherwise "distressed" condition, etc.;
- (5) Damage or loss caused in whole or in part by the acts or omissions of any kind by any party other than Taxa Inc., its agents, representatives or employees;
- (6) Damage or loss caused in whole or in part by misuse, abuse, neglect, theft, vandalism, product modification, improper owner, customer or dealer installation, incorrect line voltage, unauthorized repair or failure to properly maintain and/or to follow instructions in accordance with this manual. In particular but not limited to, damages from failure to regularly check, inspect and maintain sealants and seals around roof penetrations, attachments, windows, doors, joints, and seams shall not be covered under this limited warranty;
- (7) Routine/normal maintenance and service items including without limitation, caulking, re-caulking and waxing of the body of the habitat, tightening screws, brakes, latches, locks, changing fuses, or light bulbs, maintaining the batteries, air conditioning, heating, plumbing and electrical systems, lubricants, sealant and seals, etc., and/or damages resulting from lack of proper maintenance and servicing;
- (8) Adjustments to all doors, drawers, locks, latches, slide-outs, awnings and window treatments after ninety (90) days of the date of the original retail sale;
- (9) Damage or loss caused in whole or in part by unauthorized attachments, modifications or alterations to the structure, body, pin box, or frame of the unit including but not limited to habitat hitches, or platforms for supporting cargo;
- (10) Normal deterioration due to wear or exposure such as but not limited to upholstery damage, fading of fabrics, drapes, carpet wear, tears, punctures, dents and/or scratches to the exterior from the roadway, hanging branches, etc.;



- (11) Damage or loss caused in whole or in part by the overloading or the improper balancing/distribution of the load;
- (12) Damage or loss caused in whole or in part by the willful or negligent acts of the driver of the tow vehicle, an accident involving the habitat, the condition of any road surface over which the habitat is pulled, or the striking or driving over or through a curb or any other object;
- (13) Damage or loss to the habitat caused in whole or in part by the tow vehicle including but not limited to the improper selection or installation of towing hitch and hitch assembly on the tow vehicle;
- (14) Any injury, loss or damage due to mold, bacteria or fungi;
- (15) Damage or loss caused by or arising from the operation, use, or misuse of the tow vehicle;
- (16) Any and all damage or loss to the tow vehicle;
- (17) Damage to electronics due to voltage issues;
- (18) Representations made by any person (including your dealer) beyond those stated in this Limited Warranty;
- (19) Any incidental and consequential damages or loss, and extra expenses including, but not limited to, transportation generally, transportation to and from dealer or authorized service center or manufacturing location, loss of time, loss of pay, loss of use of the habitat, inconvenience, commercial loss, towing charges, bus and taxi fares, vehicle rental, telephone calls, fuel, food, lodging, etc.;
- (20) Damage caused by or related to: (a) Accidents, misuse, recklessness, indifference, or negligence; (b) Failure to comply with instructions contained in this Owner's Manual or any other manual related to your unit; (c) Alteration, change or modification of the habitat or damage incurred resulting from alteration, change or modification; and (d) exposure to natural atmospheric elements or environmental conditions, chemicals, ash or fumes generated or released by vehicles or any other item, collision, road hazards, rock chips, condensation, or any other source (salt, hail, Acts of God, etc.);
- (21) Damages related to moisture, condensation, mold, saturation or water;
- (22) damages to your cargo or tow loads;
- (23) damages resulting from or related to the use of your habitat in extreme weather conditions as defined in the "severe weather use" section of this manual.
- (24) any item not specifically listed in the coverage paragraphs of this section.

#### APPLIANCES/COMPONENT PARTS/ACCESSORIES

Be advised that the manufacturers of some, if not all, of your habitat's appliances, component parts, add-ons and accessories will offer you their own separate warranties. Such wholly separate, additional warranties, if any, are administered directly from and are the sole responsibility of the manufacturer of the specific component part or appliance. Taxa Inc. has no responsibility nor does it have any obligation related to these wholly separate, additional warranties, if any.

You are solely responsible for timely completing and forwarding warranty forms and registrations, and the proper processing of all warranty claims for all components, add-ons, and appliances installed in your habitat. Failure to do so may result in loss of warranty coverage by the component or appliance manufacturer. Note: upon your request, Taxa Inc. may, in its sole discretion, reasonably assist you in the processing of such separate warranty.

#### LEGAL CONSIDERATIONS

*Choice of Law* . . . to the maximum extent permitted by Law, the laws of the State of Texas shall apply to the terms of this Manual and Limited Warranty, and any and all disputes arising out of any limited warranty claim or the purchase or repair of your habitat.

*Venue* . . . to the maximum extent permitted by law, Houston, Harris County, Texas shall be the proper venue for any suit filed by you arising out of any limited warranty claim or the purchase or repair of your habitat.

*Mediation* . . . to the maximum extent permitted by law, a mediation by and through an agreed upon mediator shall be conducted prior to the filing of any suit by you arising out of any limited warranty claim or the purchase or repair of your habitat.