

Woolly Bear Assembly Instructions

Tools Required:

- WD-40
- 3/4" wrench
- 3/4" socket wrench
- 9/16" wrench
- 5/32" allen wrench

STEP 1

- Keep trailer strapped to pallet for safety
- Remove the tongue assembly from the box stand

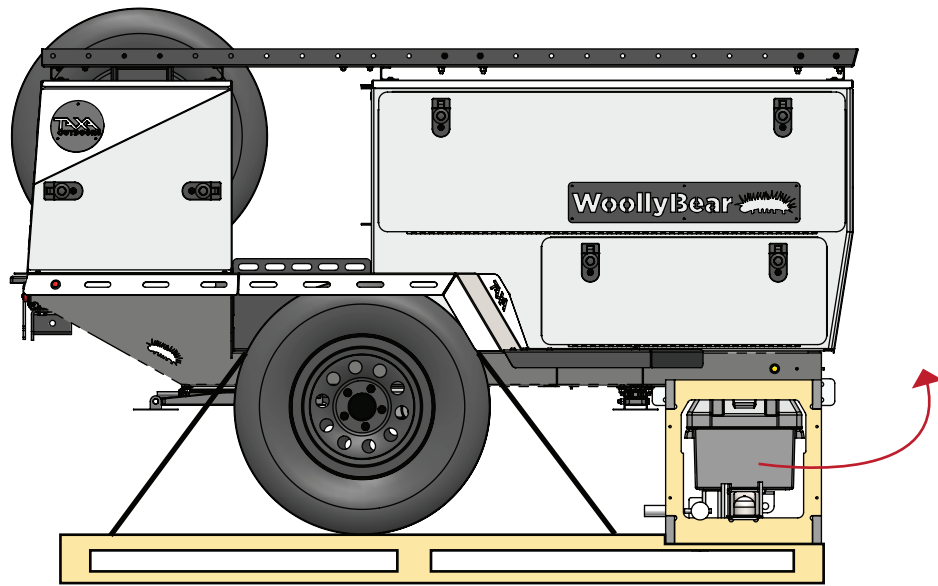

STEP 2

- Insert the tongue into the main chassis
- Install two through bolts with nuts on the sides. (torque to 80 lb-ft)
- Install the black bolt on bottom. (flip the page for details)

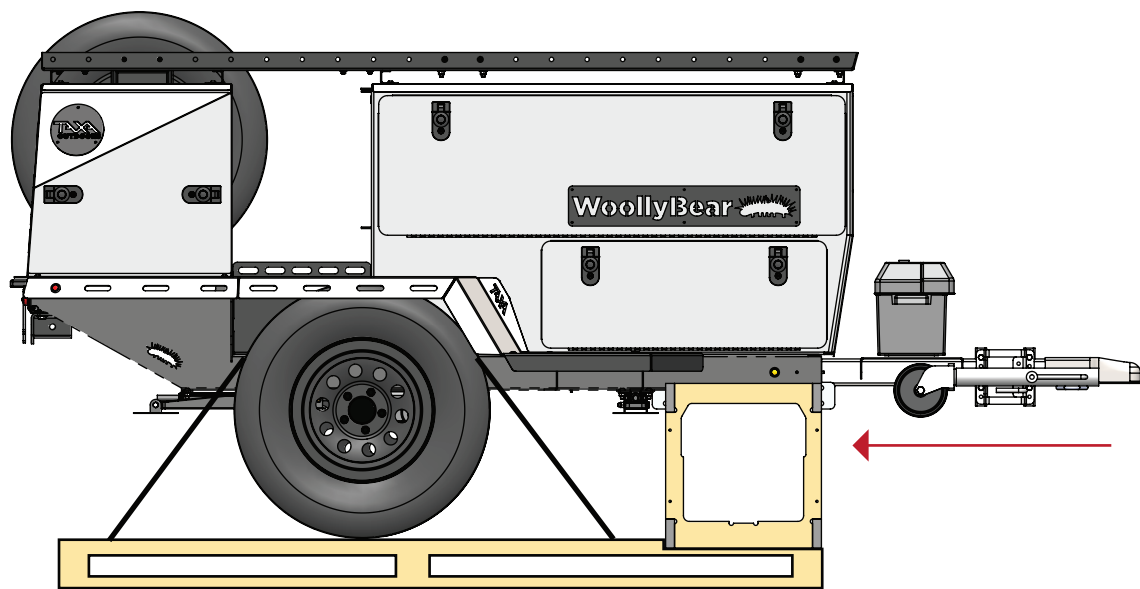

STEP 3

- Rotate the tongue jack down
- Use the crank to raise the jack. Remove the box stand
- Unstrap the trailer from pallet and roll off pallet.
- Chock wheels

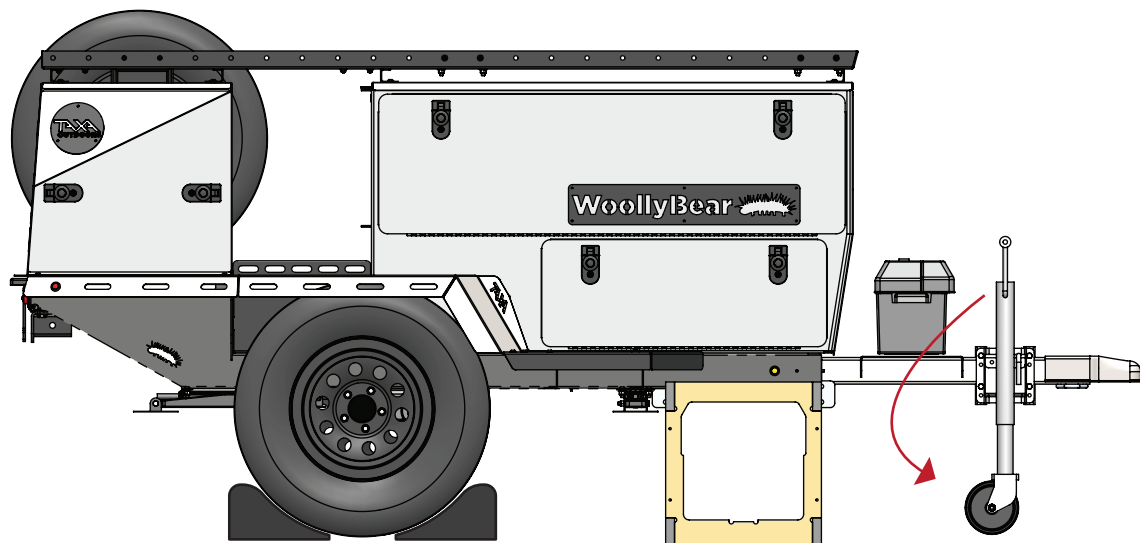

STEP 4

- Use 9/16" socket wrench for nylocks, and 5/32" allen for bolts
- Install the risers in desired position (Refer to diagram for recommended riser placement for weight distribution.) (flip the page for details)

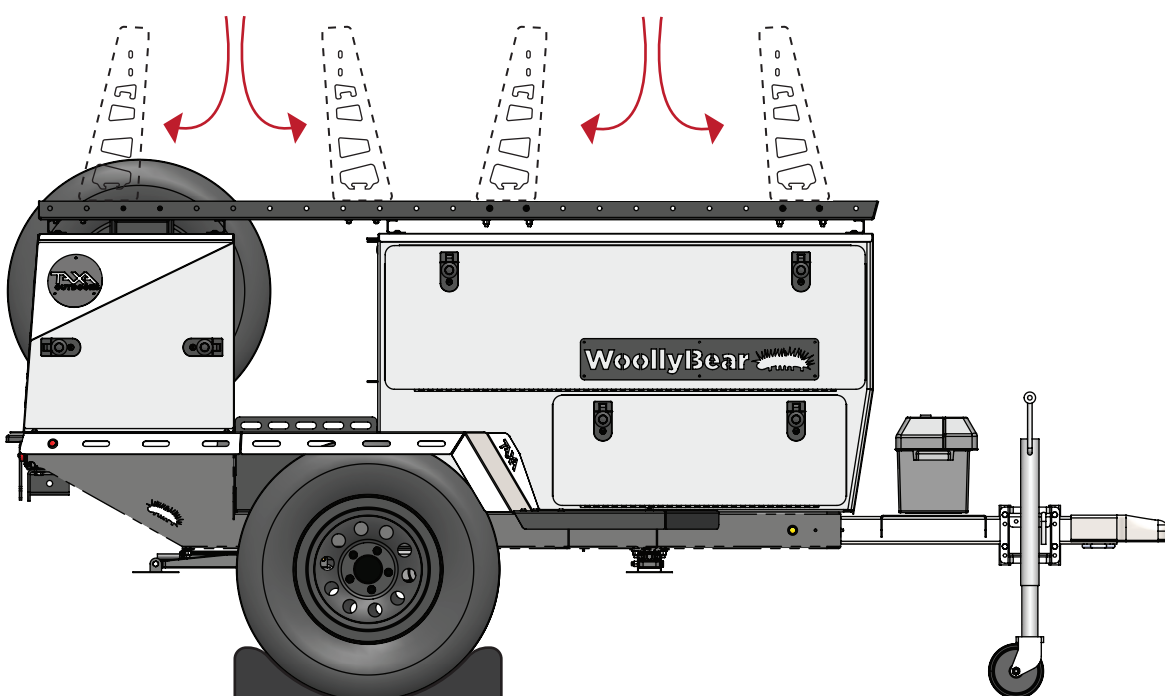

Woolly Bear Assembly Instructions

STEP 2 Detail

Installation of removable hitch.

- Remove 2 through bolts and nuts attached to removable hitch
- Remove single black bolt from bottom of removable hitch
- Use WD-40 to lubricate all 4 sides of removable hitch, then insert into the receiving hole for hitch on the chassis. (Battery box facing up)
- Align holes on removable hitch with holes on the receiving end of the chassis.
- Insert through bolts with washer on both sides, and torque to 80 lb-ft using a $\frac{3}{4}$ " ratchet wrench and $\frac{3}{4}$ " socket wrench.
- Tighten the black bolt until it is well seated.

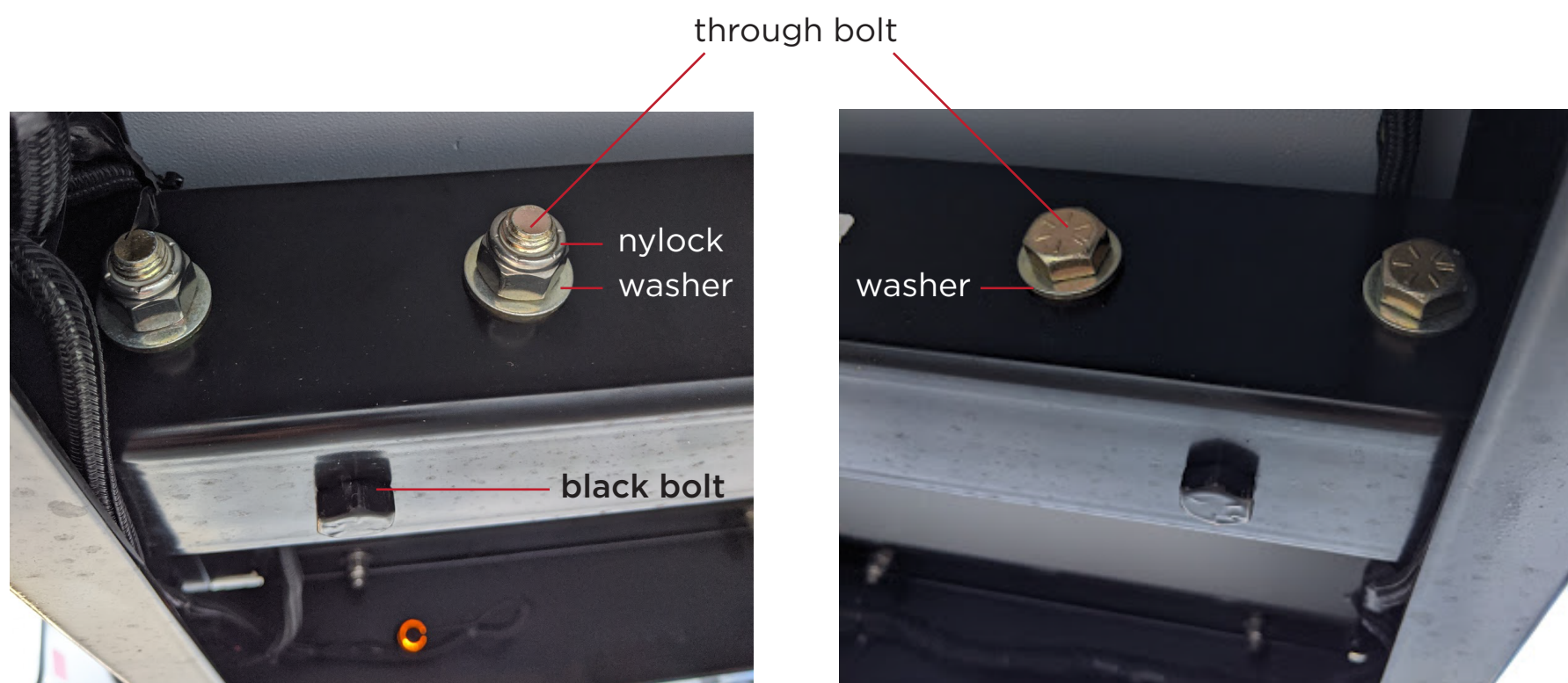

STEP 4 Detail

- For each riser leg,
- Install two bolts from outside.
 - Install two bolts from top plane.
 - Tighten all nylocks until they are well seated.
- (See drawings)

