

Product Type

POW-HVM5.5M

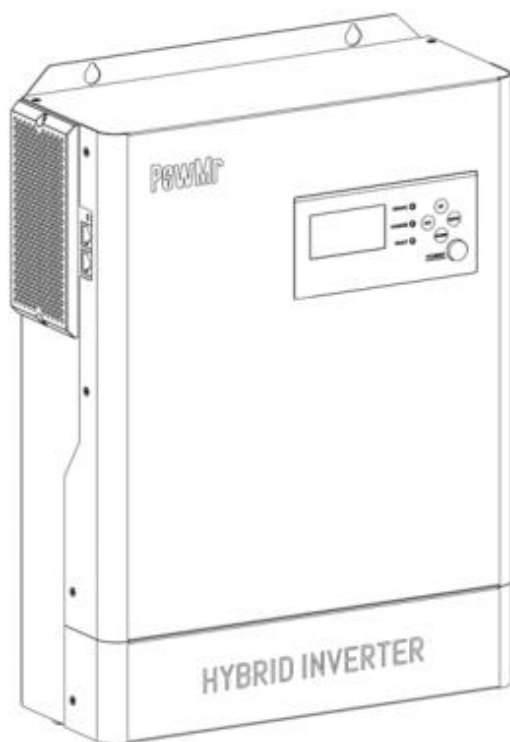

POWMr

HYBRID INVERTER

User Manual

Important Safety Instructions

Please save these instructions for future use!

Read all of the instructions and cautions in the manual before beginning the installation !

■ Purpose

This manual describes the assembly, installation, operation and troubleshooting of this unit. Please read this manual carefully before installations and operations. Keep this manual for future reference.

■ Scope

This manual provides safety and installation guidelines as well as information on tools and wiring.

■ Safety Instructions

WARNING: This chapter contains important safety and operating instructions. Read and keep this manual for future reference.

- Before using the unit, read all instructions and cautionary markings on the unit, the batteries and all appropriate sections of this manual.
- **CAUTION** --To reduce risk of injury, charge only deep-cycle lead acid type rechargeable batteries. Other types of batteries may burst, causing personal injury and damage.
- Do not disassemble the unit. Take it to a qualified service center when service or repair is required. Incorrect re-assembly may result in a risk of electric shock or fire.
- To reduce risk of electric shock, disconnect all wirings before attempting any maintenance or cleaning. Turning off the unit will not reduce this risk.
- **CAUTION** – Only qualified personnel can install this device with battery.
- **NEVER** charge a frozen battery.
- For optimum operation of this inverter/charger, please follow required spec to select appropriate cable size. It's very important to correctly operate this inverter/charger.
- Be very cautious when working with metal tools on or around batteries. A potential risk exists to drop a tool to spark or short circuit batteries or other electrical parts and could cause an explosion.
- Please strictly follow installation procedure when you want to disconnect AC or DC terminals. Please refer to INSTALLATION section of this manual for the details.
- Fuse is provided as over-current protection for the battery supply.
- **GROUNDING INSTRUCTIONS** -This inverter/charger should be connected to a permanent grounded wiring system. Be sure to comply with local requirements and regulation to install this inverter.
- **NEVER** cause AC output and DC input short circuited. Do NOT connect to the mains when DC input short circuits.
- **Warning!!** Only qualified service persons are able to service this device. If errors still persist after following troubleshooting table, please send this inverter/charger back to local dealer or service center for maintenance.

Table of Contents

Important Safety Instructions	1
Purpose	1
Scope	1
Safety Instructions	1
Introduction	4
Features	4
Basic System Architecture	5
Product Overview	6
Installation	7
Unpacking and Inspection.....	7
Select the mount location.....	7
Mount the inverter.....	8
Preparation.....	8
Connection	9
Battery Connection	9
AC Input/Output Connection	11
PV Connection.....	13
Final Assembly	15
Operation	16
Power ON/OFF	16
Operation and Display Panel	16
LCD Display Icons	17
LCD Setting	19
LCD display description	32
Operating Mode Description	37
Fault Reference Code.....	43
Warning Indicator.....	45
Battery Equalization	47
Setting For Lithium Battery	49
Lithium Battery Connection.....	49
Setting for PYLON US2000 lithium battery.....	50

Setting for lithium battery without communication.....	51
Specifications.....	53
Table 1 Line Mode Specifications.....	53
Table 2 Inverter Mode Specifications.....	54
Table 3 Charge Mode Specifications.....	55
Table 4 General Specifications.....	56
Trouble Shooting	57
Parallel Installation Guide	59
Instruction.....	59
Package Contents	59
Mounting the Unit.....	59
Wiring Connection	60
Parallel Operation in Single phase.....	62
Support 3-phase equipment.....	65
PV Connection.....	67
Commissioning	67
Trouble shooting.....	69

Introduction

This is a multi-function inverter/charger, combining functions of inverter, MPPT solar charger and battery charger to offer uninterruptible power support with portable size. Its comprehensive LCD display offers user-configurable and easy-accessible button operation such as battery charging current, AC/solar charger priority, and acceptable input voltage based on different applications.

■ Features

- Pure sine wave inverter
- Inverter running without battery
- Built-in MPPT solar controller
- Configurable input voltage range for home appliances and personal computers via LCD setting
- Configurable battery charging current based on applications via LCD setting
- Configurable AC/Solar Charger priority via LCD setting
- Compatible to mains voltage or generator power
- Auto restart while AC is recovering
- Overload/ Over temperature/ short circuit protection
- Smart battery charger design for optimized battery performance
- Cold start function
- Self-consumption and feed-in to the grid
- Statistics and records of power generation

■ Basic System Architecture

The following illustration shows basic application for this inverter/charger. It also includes following devices to have a complete running system:

1. Generator or Utility.
2. PV modules (option)

Consult with your system integrator for other possible system architectures depending on your requirements.

This inverter can power all kinds of appliances in home or office environment, including motor-type appliances such as tube light, fan, refrigerator and air conditioner.

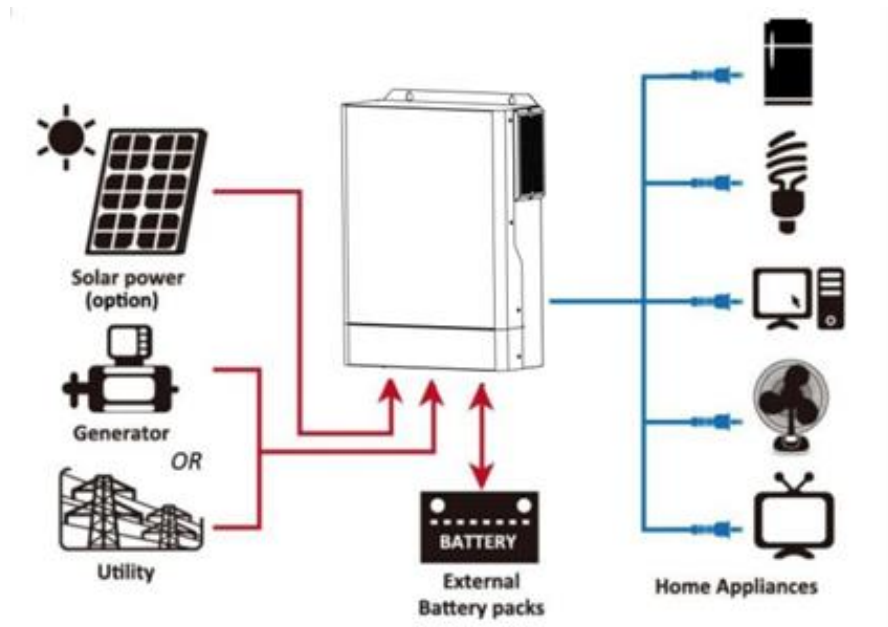
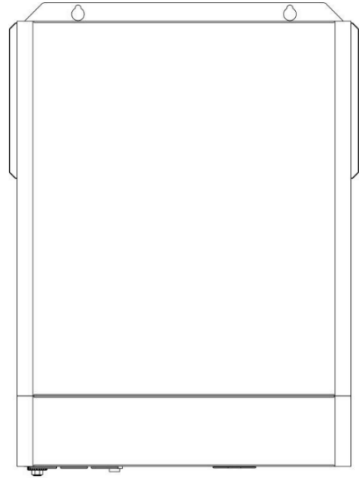
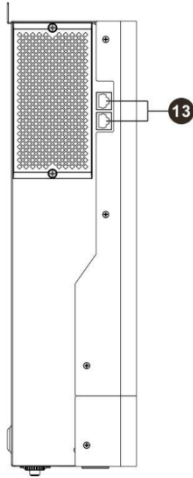
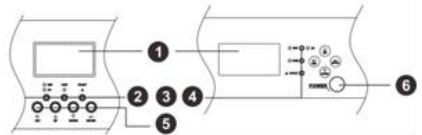
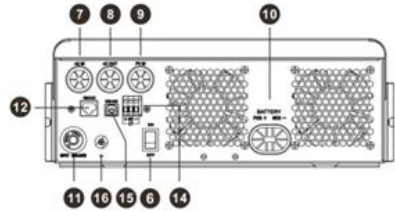

Figure 1 Hybrid Power System

■ Product Overview



1. LCD display
2. Status indicator
3. Charging indicator
4. Fault indicator
5. Function buttons
6. Power on/off switch
7. AC input
8. AC output
9. PV input
10. Battery input
11. Circuit breaker
12. RS232 communication port
13. Parallel communication port
(only for parallel model)
14. AC grid current sensor
15. RS485 communication port
16. Grounding



NOTE: For parallel model installation and operation, please check the parallel installation guide for the details.

Installation

■ Unpacking and Inspection

Before installation, please inspect the unit. Be sure that nothing inside the package is damaged.

You should have received the following items inside of package:

- 1.The unit x 1
- 2.User manual x 1

■ Select the mount location

Consider the following points before selecting where to install:

1. Do not mount the inverter on flammable construction materials.
2. Mount on a solid surface.
3. Install this inverter at eye level in order to allow the LCD display to be read at all times.
4. The ambient temperature should be between 0°C and 55°C to ensure optimal operation.
5. The recommended installation position is to be adhered to the wall vertically.
6. Be sure to keep other objects and surfaces as shown in the right diagram to guarantee sufficient heat dissipation and to have enough space for removing wires.

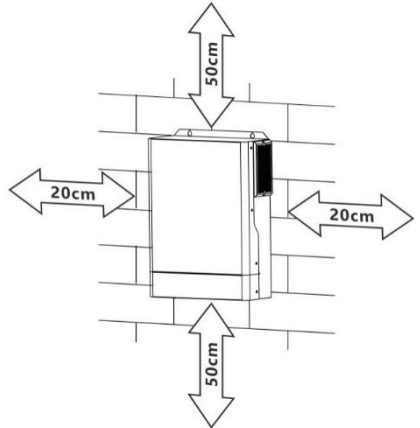

SUITABLE FOR MOUNTING ON CONCRETE OR OTHER NON-COMBUSTIBLE SURFACE ONLY.

■ Mount the inverter

Install the unit by screwing three screws. It's recommended to use M4 or M5 screws.

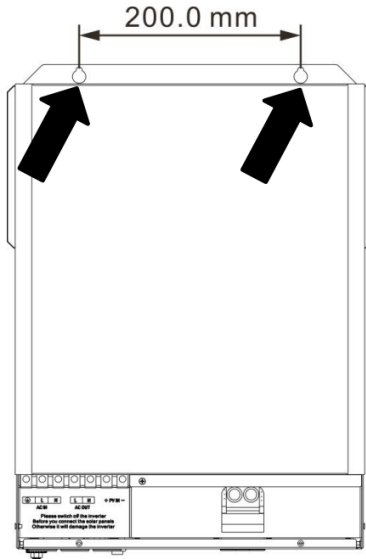

■ Preparation

Before connecting all wirings, please take off bottom cover by removing two screws as shown below.

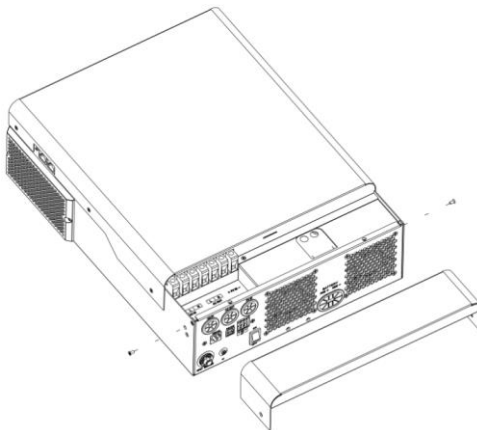

Connection

■ Battery Connection

- Recommended battery cable, stripping length (L2) and tinning length(L1):

Model	Maximum Amperage	Battery capacity	Wire Size	Cable mm ²	L1(mm)	L2(mm)	Torque value
5KVA	137A	200AH	2AWG	38	3	18	2~ 3 Nm

CAUTION

- For safety operation and regulation compliance, it's requested to install a separate DC over-current protector or disconnect device between battery and inverter. It may not be requested to have a disconnect device in some applications, however, it's still requested to have over-current protection installed. Please refer to typical amperage in below table as required fuse or breaker size.

WARNING

- All wiring must be performed by a qualified personnel.
- It's very important for system safety and efficient operation to use appropriate cable for battery connection. To reduce risk of injury, please use the proper recommended cable, stripping length (L2) and tinning length (L1) as shown on the right.

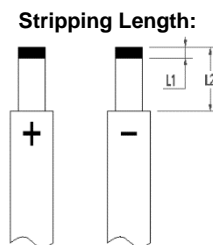

- Please follow below steps to implement battery connection

1. Remove insulation sleeve 18 mm for positive and negative cables based on recommended stripping length.
2. Connect all battery packs as units requires. It's suggested to use recommended battery capacity.
3. Insert battery cable flatly into battery connector of inverter and make sure the bolts are tightened with torque of 2-3 Nm. Make sure polarity at both the battery and the inverter/charge is correctly connected and the battery cables are tightly screwed to the battery connector.

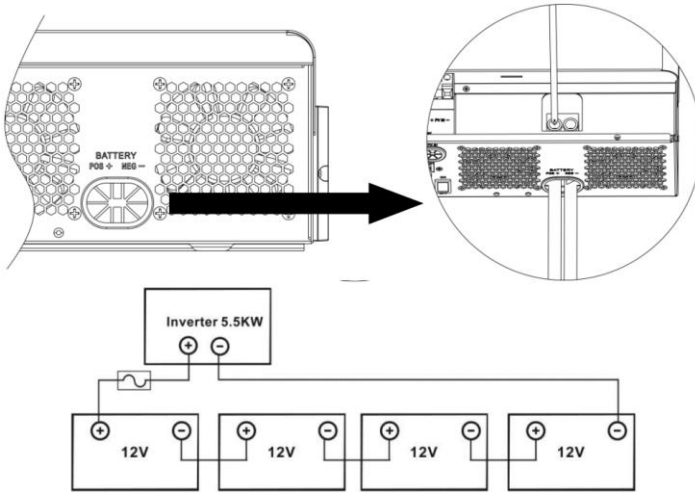

CAUTION

- Do not place anything between the flat part of the inverter terminal. Otherwise, overheating may occur.
- Do not apply anti-oxidant substance on the terminals before terminals are connected tightly.
- Before making the final DC connection or closing DC breaker/disconnector, be sure positive (+) must be connected to positive (+) and negative (-) must be connected to negative (-).

WARNING

- Installation must be performed with care due to high battery voltage in series.

■ AC Input/Output Connection

● Suggested cable requirement for AC wires

Model	Gauge	Torque Value
5KVA	8 AWG	1.4~ 1.6Nm

CAUTION

- Before connecting to AC input power source, please install a separate AC breaker between inverter and AC input power source. This will ensure the inverter can be securely disconnected during maintenance and fully protected from over current of AC input. The recommended spec of AC breaker is 50A.
- There are two terminal blocks with "IN" and "OUT" markings. Please do NOT mis-connect input and output connectors.

WARNING

- All wiring must be performed by a qualified personnel.
- It's very important for system safety and efficient operation to use appropriate cable for AC input connection. To reduce risk of injury, please use the proper recommended cable size as below.

● Please follow below steps to implement AC input/output connection

1. Before making AC input/output connection, be sure to open DC protector or disconnecter first.
2. Remove insulation sleeve 10mm for six conductors. And shorten phase L and neutral conductor N 3mm.
3. Insert AC input wires according to polarities indicated on terminal block and tighten the terminal screws. Be sure to connect PE protective conductor (⊕) first.

⊕→Ground (yellow-green) L→LINE (brown or black) N→Neutral (blue)

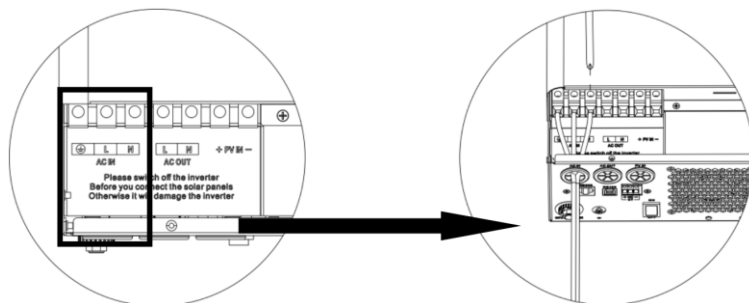

WARNING

- Be sure that AC power source is disconnected before attempting to hardwire it to the unit.

4. Then, insert AC output wires according to polarities indicated on terminal block and tighten terminal screws. Be sure to connect PE protective conductor (⊕) first.

⊕ → Ground (yellow-green) L → LINE (brown or black) N → Neutral (blue)

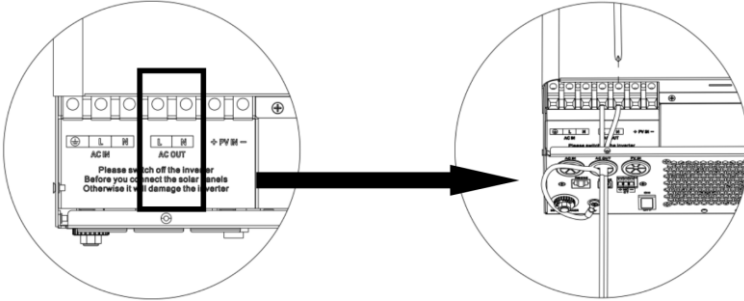

5. Make sure the wires are securely connected.

CAUTION

- Be sure to connect AC wires with correct polarity. If L and N wires are connected reversely, it may cause utility short-circuited when these inverters are worked in parallel operation.
- Appliances such as air conditioner are required at least 2~3 minutes to restart because it's required to have enough time to balance refrigerant gas inside of circuits. If a power shortage occurs and recovers in a short time, it will cause damage to your connected appliances. To prevent this kind of damage, please check manufacturer of air conditioner if it's equipped with time-delay function before installation. Otherwise, this inverter/charger will trig overload fault and cut off output to protect your appliance but sometimes it still causes internal damage to the air conditioner.

CT Connection

Inverter will not only provide power to the backup load connected but also give power to the home load connected. If PV power is insufficient, it will take grid energy as supplement. The inverter will not sell power to grid. In this mode, a CT is needed. The installation method of the CT please refer to the chapter. The external CT will detect power flowing back to the grid and will reduce the power of the inverter only to supply the local load, charge battery and home load.

NOTICE

- When the reading of the load power on the LCD is not correct, please reverse the CT arrow.
- The external CT will become available after finishing setting program 12 of F0 group.

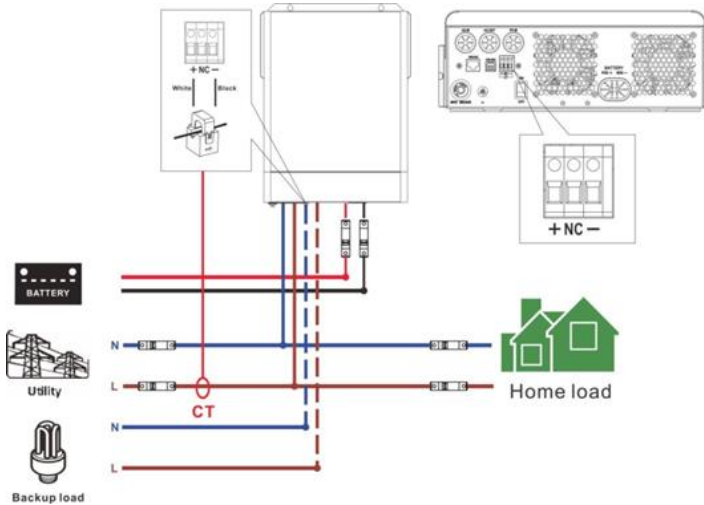

■ PV Connection

Suggested cable requirement for AC wires

Model	Typical Amperage	Cable Size	Torque
5KVA	18A	12 AWG	1.4~1.6 Nm

CAUTION

Before connecting to PV modules, please install separately a DC circuit breaker between inverter and PV modules.

WARNING

All wiring must be performed by a qualified personnel.

It's very important for system safety and efficient operation to use appropriate cable for PV module connection. To reduce risk of injury, please use the proper recommended cable size as below.

PV Module Selection

When selecting proper PV modules, please be sure to consider below parameters:

1. Open circuit Voltage (Voc) of PV modules not exceeds max. PV array open circuit voltage of inverter.
2. Open circuit Voltage (Voc) of PV modules should be higher than min. battery voltage.

Solar Charging Mode	
INVERTER MODEL	5KVA
Max. PV Array Open Circuit Voltage	500VDC
PV Array MPPT Voltage Range	120VDC~450VDC

Take the 330Wp PV module as an example. After considering above two parameters, the recommended module configurations are listed in the table below.

Solar Panel Spec. (reference)	SOLAR INPUT	Q'ty of panels	Total input power	Inverter Model
	- 330Wp			
- Vmp: 33.25Vdc	6 pcs in serial	6 pcs	1980W	5KVA
- Imp: 9.925A	10 pcs in serial	10 pcs	3300W	
- Voc: 40.35Vdc	12 pcs in serial	12 pcs	3960W	
- Isc: 10.79A	6 pieces in serial and 2 sets in parallel	12 pcs	3960W	
- Cells: 60	8 pieces in serial and 2 sets in parallel	16 pcs	5280W	

PV Module Wire Connection:

Please follow below steps to implement PV module connection:

1. Remove insulation sleeve 10 mm for positive and negative conductors.
2. Check correct polarity of connection cable from PV modules and PV input connectors. Then, connect positive pole (+) of connection cable to positive pole (+) of PV input connector. Connect negative pole (-) of connection cable to negative pole (-) of PV input connector.

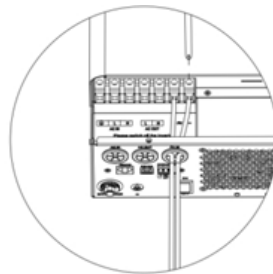
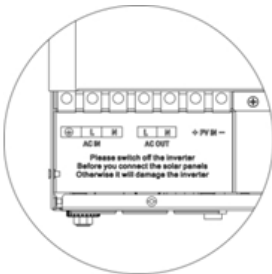

3. Make sure the wires are securely connected.

■ Final Assembly

After connecting all wirings, please put bottom cover back by screwing two screws as shown below.

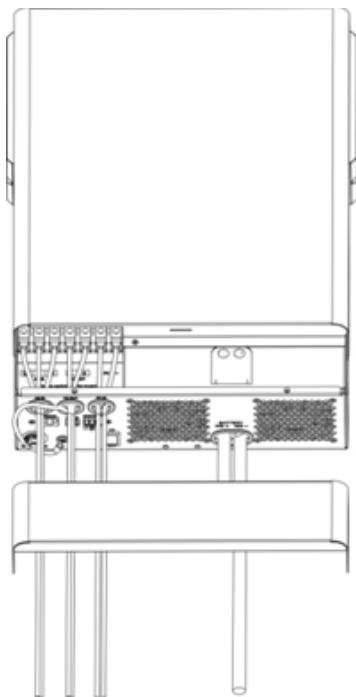

Operation

■ Power ON/OFF

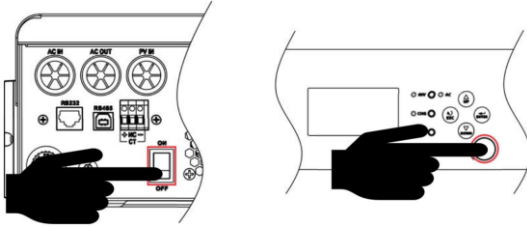

Once the unit has been properly installed and the batteries are connected well, simply press On/Off switch (located on the button of the case) to turn on the unit.

■ Operation and Display Panel

The operation and display panel, shown in below chart, is on the front panel of the inverter. It includes three indicators, four function keys and a LCD display, indicating the operating status and input/output power information.

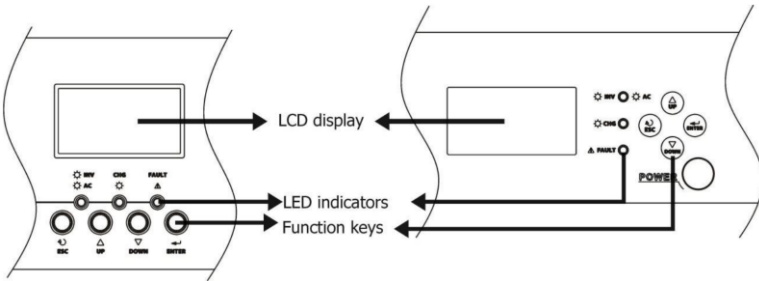

● LED Indicator

LED Indicator		Messages	
☀️ AC / 🌞 INV	Green	Solid On	Output is powered by utility in Line mode.
		Flashing	Output is powered by battery or PV in battery mode.
☀️ CHG	Green	Solid On	Battery is fully charged.
		Flashing	Battery is charging.
⚠️ FAULT	Red	Solid On	Fault occurs in the inverter.
		Flashing	Warning condition occurs in the inverter.







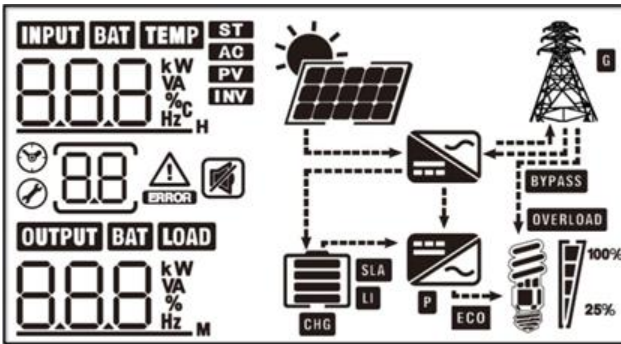



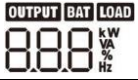



● **Function Keys**

Function Key	Description
ESC	To exit setting mode
UP	To go to previous selection
DOWN	To go to next selection
ENTER	To confirm the selection in setting mode or enter setting mode

■ **LCD Display Icons**



Icon	Function description
Input Source Information	
AC	Indicates the AC input.
PV	Indicates the PV input
INPUT BATT 888 kW VA % Hz	Indicate input voltage, input frequency, PV voltage, battery voltage and charger current.
Configuration Program and Fault Information	
⚙️ 88	Indicates the setting programs.
88 ⚠️	Indicates the warning and fault codes.
88 ⚠️	Warning: 88 ⚠️ flashing with warning code.
88 ERROR	Fault: 88 ERROR lighting with fault code

Output Information				
		Indicate output voltage, output frequency, load percent, load in VA, load in Watt and discharging current.		
Battery Information				
		Indicates battery level by 0-24%, 25-49%, 50-74% and 75-100% in battery mode and charging status in line mode.		
Load Information				
		Indicates overload.		
		Indicates the load level by 0-24%, 25-49%, 50-74% and 75-100%.		
		0%~24%	25%~49%	50%~74%
				
				
Mode Operation Information				
		Indicates unit connects to the mains.		
		Indicates unit connects to the PV panel.		
		Indicates load is supplied by utility power.		
		Indicates the utility charger circuit is working.		
		Indicates the DC/AC inverter circuit is working.		
Mute Operation				
		Indicates unit alarm is disabled.		

■ LCD Setting

1. Pressing and holding ENTER button for 3 seconds, the unit will enter setting groups mode.
2. Press “UP” or “DOWN” button to select setting groups. There are 5 groups setting menu include F0/F1/F2/F3/F4, press “ENTER” button to confirm the selection or ESC button to exit.

F0: Setting general parameters

F1: Setting AC output parameters

F2: Setting battery parameters

F3: Setting time parameters

F4: Setting systems parameters

3. Press “ENTER” button to confirm the selection groups or ESC button to return selection groups or exit.

Setting F0 Programs:



NO	Description	Selectable option	
01	AC input voltage range	Appliances (default) APL	If selected, acceptable AC input voltage range will be within 90-280VAC.
		UPS UP5	If selected, acceptable AC input voltage range will be within 170-280VAC.
		Generator GNE	If selected, acceptable AC input voltage range will be within 170- 280VAC and compatible with generators. Note: Because generators are unstable, maybe the output of inverter will be unstable too.
02	Power saving mode enable/disable	Saving mode disable (default) SD5	If disabled, no matter connected load is low or high, the on/off status of inverter output will not be effected.
		Saving mode enable	If enabled, the output of inverter will be off when

		9EN	connected load is pretty low or not detected.
03	Overload bypass: When enabled, the unit will transfer to line mode if overload occurs in battery mode.	Bypass disable (default) bYd	Bypass enable bYE
04	Auto restart when overload occurs	Restart disable (default) Lfd	Restart enable LFE
05	Auto restart when over temperature occurs	Restart disable (default) tfd	Restart enable tFE
06	Auto bypass When selecting "auto", if the mains power is normal, it will automatically bypass, even if the switch is off.	Manual(default) nNL	Auto Ato
07	Auto return to default display screen	Return to default display screen (default) ESP	If selected, no matter how users switch display screen, it will automatically return to default display screen (Input voltage/output voltage) after no button is pressed for 1 minute.
		Stay at latest screen uEP	If selected, the display screen will stay at latest screen user finally switches.
08	Backlight control	Backlight on (default)	Backlight off

		LoN	LoF
09	Buzzer mode	Mode1 nd1	Buzzer mute
		Mode2 nd2	The buzzer sounds when the input source changes or there is a specific warning or fault
		Mode3 nd3	The buzzer sounds when there is a specific warning or fault
		Mode4(default) nd4	The buzzer sounds when there is a fault
10	Modbus ID Setting	Modbus ID Setting Range : 001(default)~247 001;002;003	
12	External CT setting (Only apply for setting "ZEC priority" in program 01 of F1 groups: Output source priority)	Disable(default) di 5	When "DIS" is selected, the units will calculate the AC feed-in power with internal current sensor
		Enable ENA	When "ENA" is selected, the units will calculate the AC feed-in power with external current sensor
13	External CT detection error compensation	Default 100	When there is detection error between external CT detection current and the rated current, you need to set this program, the setting range is form 0 to 200.The reduction range is from 0-100 and the addition

range is from 100-200.

Setting F1 Programs:

NO	Description	Selectable option	
01	Output source priority	SUB priority (default) 	<p>Solar->Utility->Battery</p> <p>Solar energy is charged first and then power to the loads.</p> <p>If solar energy is not sufficient to power all connected loads, Utility energy will supply power to the loads at the same time.</p>
		SBU priority 	<p>Solar-> Battery ->Utility</p> <p>Solar energy provides power to the loads as first priority.</p> <p>If solar energy is not sufficient to power all connected loads, battery energy will supply power to the loads at the same time.</p> <p>Utility provides power to the loads only when battery voltage drops to either low-level warning voltage or the setting point in program 05 of F2 group.</p>
		SUF priority 	<p>Solar-> Utility->Battery</p> <p>If solar energy is sufficient to all connected loads and charge battery, the solar</p>

		<p>energy could feedback to the grid (sell power to grid), but the feedback power must be less than the setting point in program 05 of F1 group.</p> <p>If solar energy is not sufficient to power all connected loads, Utility energy will supply power to the loads at the same time.</p>
	<p>ZEC priority (Zero Export To CT)</p> 	<p>Solar->Battery- > Utility Self-use mode</p> <p>The units will not only provide power to the connected load but also give power to connected home load. If PV power and battery power is insufficient, it will take grid energy as supplement. The units will not sell power to grid. In this mode, a CT is needed. The installation method of the CT please refer to chapter about CT connection. The external CT will detect power flowing back to the grid and will reduce the power of the inverter only to supply the local load, charge battery and home load.</p> <p>Note: you must finish setting</p>

			the program 12 of F0 group as "Enable"
02	AC output mode	Single: This inverter is used in single phase application. 5 0	Parallel: This inverter is operated in parallel system. (Need hardware support) PAL
		L1 phase 3P 1	The inverter is operated in L1 phase in 3-phase application
		L2 phase 3P 2	The inverter is operated in L2 phase in 3-phase application
		L3 phase 3P 3	The inverter is operated in L3 phase in 3-phase application
03	Output voltage	220V 220 ^v	230V (default) 230 ^v
		240V 240 ^v	
04	Output frequency	50Hz (default) 050 _{Hz}	60Hz 060 _{Hz}
05	MAX feedback power to Grid	5kw(default) 5.00 ^{kw}	When the output source priority is selected as "SUF", there is MAX feedback power to grid, the setting range is from 200w to 5000w
06	Salve output source priority The priority is available after	OFF (default)	Turn off salve output source priority

	setting application period, the units will turn to salve priority in the setting period from main priority	oFF	The same as in program 01 of F1 group.
		SUB priority 9Ub	
		SBU priority 9bU	
		SUF priority 9UF	
		ZEC priority 7EC	
07	Start timer setting for salve output source priority - Hours setting	03	The setting range is from 00 to 23 of every day
08	Start timer setting for salve output source priority - Minutes setting	15	The setting range is from 00 to 59 of every hour
09	End timer setting for salve output source priority - Hours setting	05	The setting range is from 00 to 23 of every day
10	End timer setting for salve output source priority - Minutes setting	45	The setting range is from 00 to 59 of every hour

Setting F2 Programs:

NO	Description	Selectable option	
01	Battery type	AGn	AGM (default)
		FLd	Flooded

		USE	User-Defined If "User-Defined" is selected, battery charge voltage and low DC cut-off voltage can be set up in program 03,04 and 07 of F2 group.
		L1	Standard communication Protocol 1 for inverter supplier
		L2	Support PYLON US2000 Protocol
		L3	Customized Protocol or Support FOX ESS Lithium Battery Protocol
		L4	Standard communication Protocol 2 form inverter supplier
02	Charger source priority: To configure charger source priority	If this inverter/charger is working in Line, Standby or Fault mode, charger source can be programmed as below:	
		Solar first Sof	Solar energy will charge battery as first priority. Utility will charge battery
		Solar and Utility (default) SNU	Solar energy and utility will charge battery at the same time.
		Only Solar oS	Solar energy and utility will charge battery at the same time.
		Solar residual Sot	Solar energy will support all connected loads as first priority, residual energy will charge battery.

03	Bulk charging voltage (C.V voltage)	56.4V(default) 56.4_v	If self-defined is selected in program 5, this program can be set up. Setting range is 48.0V to 62.0V.
04	Floating charging voltage	54.0V(default) 54.0_v	If self-defined is selected in program 5, this program can be set up. Setting range is from 48.0V to 62.0V.
05	Setting voltage point back to utility source when selecting "SBU priority" in program 01.	46V (default) 46.0_v	If selected, acceptable voltage range will be from the value in program 07(F2) to the value in program 03(F2).
06	Setting voltage point back to battery mode when selecting "SBU priority" in program 01(F1).	Battery fully charged (default) FUL	If selected, acceptable voltage range will be from the value in program 05(F2) to the value in program 03(F2).
07	Low DC cut-off voltage	42.0V (default) 42.0_v	If self-defined is selected in program 5, this program can be set up from 40.0V to 54.0V. Low DC cut-off voltage will be fixed to setting value no matter what percentage of load is connected.
08	Maximum charging current: To configure total charging current for solar and utility chargers. (Max. charging current = utility charging current + solar charging current)	60A (default) 060_A	If selected, acceptable charging current range will be within 1-100A, but it shouldn't be less than the AC charging current (program 09(F2))

09	Maximum utility charging current	30A (default) 030 ^A	If selected, acceptable charging current range will be within 1-60A
10	Slave charger source priority The priority is available after setting application period, the units will turn to slave priority in the setting period form main priority	OFF (default) off	Turn off slave charger source priority
		Solar first 5of	The same as in program 02 of F2 group.
		Solar and Utility (default) 5nu	
		Only Solar o5o	
		Solar residual 5of	
11	Start timer setting for slave charger source priority- Hours setting	03	The setting range is from 00 to 23 of every day
12	Start timer setting for slave charger source priority - Minutes setting	15	The setting range is from 00 to 59 of every hour
13	End timer setting for slave output charger priority - Hours setting	05	The setting range is from 00 to 23 of every day
14	End timer setting for slave charger source priority - Minutes setting	45	The setting range is from 00 to 59 of every hour
15	Bulk charging time (C.V stage)	Automatically (Default)	If selected, inverter will judge this charging time

		AEU	automatically.
		5 min 005	The setting range is from 5 min to 900 min. Increment of each click is 5 min.
		900 min 900	
		If "USE" is selected in program 01 of F2 group, this program can be set up.	
16	Battery equalization	Battery equalization EEN	Battery equalization disable (default) Ed5
		If "Flooded" or "User-Defined" is selected in program 05, this program can be set up.	
17	Battery equalization voltage	Default setting is 58.4V. 58.4 ^v	Setting range is from 48V ~ 64V. Increment of each click is 0.1V.
18	Battery equalized time	60min (default) 60	Setting range is from 5min to 900min. Increment of each click is 5min.
19	Battery equalized timeout	120min (default) 120	Setting range is from 5min to 900 min. Increment of each click is 5 min.
20	Equalization interval	30days (default) 30d	Setting range is from 0 to 90 days. Increment of each click is 1 day
21	Equalization activated	Enable	Disable (default)

	immediately	REN	AdS
		<p>If equalization function is enabled in program 16, this program can be set up. If “Enable” is selected in this program, it’s to activate battery equalization immediately and LCD main page will shows “EQ”. If “Disable” is selected, it will cancel equalization function until next activated equalization time arrives based on program 18 setting. At this time, “EQ” will not be shown in LCD main page.</p>	
22	Manual activate the lithium battery setting	Disable(default) NoP	Active ACT
24	Setting SOC point back to utility source when selecting “SBU priority in program 01 of group F2	050 %	Default 50%, 20%~50% Settable
25	Setting SOC point back to battery mode when selecting “SBU priority” in program 01 of group F2	095 %	Default 95%, 60%~100% Settable
26	Low DC cut-off SOC	020 %	Default 20%, 5%~30% Settable
27	Max battery discharge current setting	OFF (default) off	When the battery discharge current more than the setting value, the unit will stop discharging and go to bypass mode or standby mode. The setting range is from 50 to 500
		500 A	

Setting F3 Programs:

NO	Description	Selectable option	
01	Time setting –Year	000;00 1...099	For year setting, the range is from 00 to 99.
02	Time setting–Month	00 1;002...0 12	For month setting, the range is from 1 to 12.
03	Time setting–Day	00 1;002...03 1	For day setting, the range is from 1 to 31.
04	Time setting –Hour	000;00 1...023	For hour setting, the range is from 0 to 23.
05	Time setting –Minute	000;00 1...059	For minute setting, the range is from 0 to 59.
06	Time setting –Second	000;00 1...059	For second setting, the range is from 0 to 59.

Setting F4 Programs:

NO	Description	Selectable option	
01	Reset all stored data of PV generated power and output load energy	Reserve data(default) No	Reset generated energy data YES
02	Reset data log	Reserve data log (default) No	Reset data log(default) YES

■ LCD display description

The LCD display information will be switched in turns by pressing “UP” or “DOWN” key. all of information could be show in 1/2/3 area of LCD.

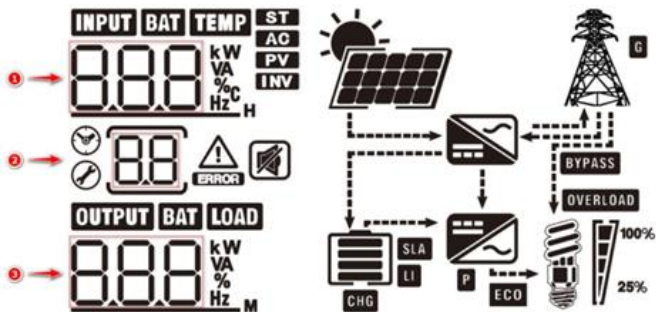

LCD display information			
Item	1 area data	3 area data	For Example
1	Input Voltage	Output Voltage	Input Voltage=220V, Output Voltage=220V (Default Display Screen)
2	Input Frequency	Output Frequency	Input Frequency=50Hz Output Frequency=50Hz
3	Output Active Power	Output Apparent Power	Active Power=3.2KW Apparent Power=4.0KVA

4	Input Active Power	PV Feedback Power	<p>Active Power=800w Feedback Power=0w</p>
5	Battery Voltage	Load Percentage	<p>Battery Voltage=50V Load Percentage=80%</p>
6	Charging Power	Charging Current	<p>Total Charging Power=1.8KW Charging Current=36A Icon AC and PV is light show that AC grid and PV charging battery at the same time</p>
7	PV Power	Discharge Current	<p>PV Power=1.0KW Battery Discharge current is 0 A</p>

8	PV Voltage	PV Current	<p>PV Voltage=250V PV Current=4A</p>
9	DAY	Generation Power/day	<p>Generation Power/day=10KWh</p>
10	MON	Generation Power/Month	<p>Generation Power /month=310KWh</p>
11	YEA	Generation Power/Year	<p>Generation power /year=3.6MWh</p>
12	TTL	Total Generation Power	Total Generation Power=13.6MWh

13	Year	Month	Day	2022/01/17
14	Hour	Second	Minute	21:31 11s
Only communication between the inverter and battery is successful, communication successful icon LI will be flashing, there is some information showing on the LCD				
Item	1 area data	3 area data	For Example	
15	Max Lithium Battery Charging Voltage	Max Lithium Battery Charging Current		
16	Lithium battery discharging is forbidden	Lithium battery charging is forbidden		





17	Lithium battery SOC(AH)	Lithium battery SOC (%)	
----	----------------------------	-------------------------	--

Other LCD display information

Please press and hold the “Down” button for a long time on main menu page, you could see the follow information.

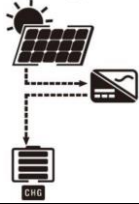

Item	1 Area data	2 Area data	2 Area data	For Example
18	Software Version part1	Software Version Part2	Software Version Part3	
19	Model code Version part1	Model code Version Part2	Model code Version Part3	
20	CPU type	HD	Hardware Version	

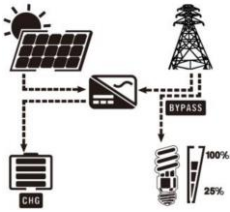
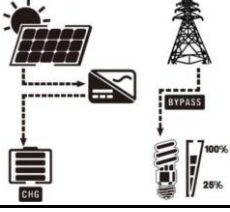
■ Operating Mode Description

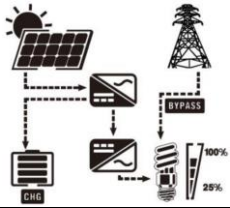
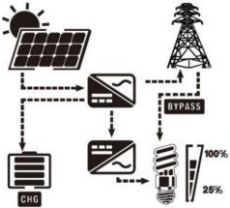
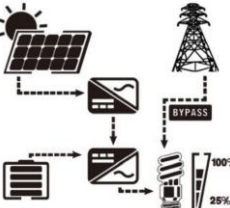
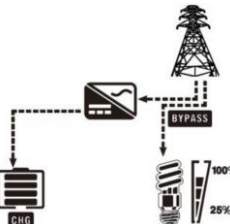

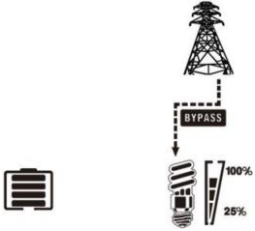
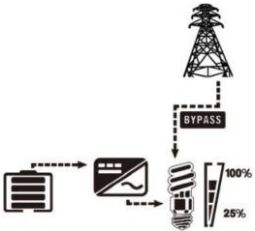
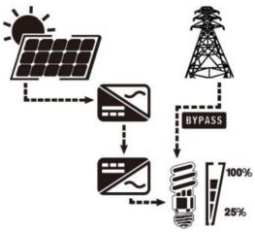
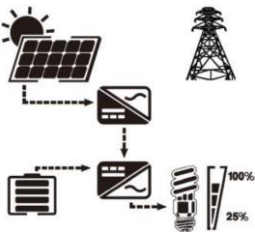
Operation mode	Description	LCD display
Standby mode	No output is supplied by the unit but it still can charge batteries.	Charging by PV energy. 
		Only Battery 
		Only PV 
		Only utility 
Line mode	The unit will provide output power from the utility. PV or battery is ok or both are available.	Charging battery by utility and PV energy. 
		Charging battery by PV energy.  The unit will provide output power from

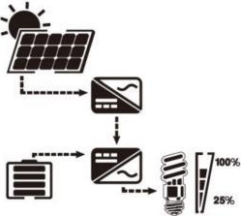
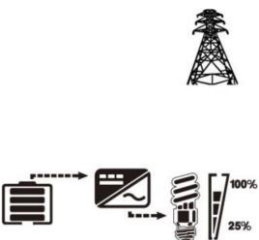
		<p>the utility and PV energy. It will also charge battery by PV energy.</p> 
Line mode		<p>Charging battery by PV energy and PV energy will feedback to utility.</p> 
	<p>The unit will provide output power from the utility and PV or battery is ok or both are available.</p>	<p>If "ZEC" is selected as output source priority, PV energy and battery will support the output load with utility.</p> 
		<p>Charging by utility.</p> 
		<p>Power from utility.</p>

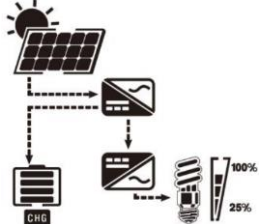
<p>Line mode</p>	<p>The unit will provide output power from the utility and PV or battery is ok or both are available.</p>	
		<p>If "ZEC" is selected as output source priority, Power from battery and utility.</p> 
		<p>Power from PV energy and utility</p> 
<p>Off-Grid mode</p>	<p>Utility is unavailable or stand-by. PV energy and battery will provide output load</p>	<p>PV energy and battery provide output load, utility is standby.</p> 
		<p>PV energy and battery provide output load, utility is unavailable</p>

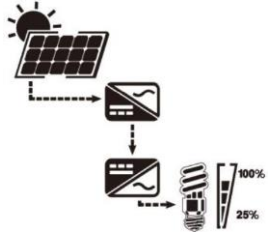
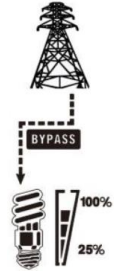
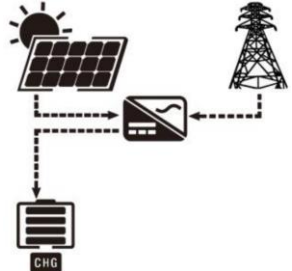
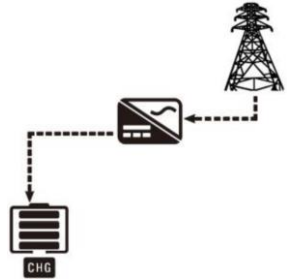
<p>Off-Grid mode</p>	<p>Utility is unavailable or stand-by. PV energy and battery will provide output load</p>	
		<p>Battery provides output load, utility is standby.</p> 
		<p>Only battery provides output load.</p> 
		<p>Only PV energy provides output load and charge battery.</p> 
		<p>Only PV energy provides output load (It is only available for single model)</p>

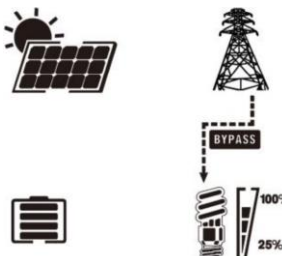
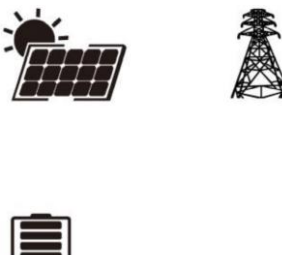
		
Bypass mode	The unit will provide output power from the utility. PV or battery is unavailable.	
Charge mode	No output is supplied by the unit but it still can charge batteries.	<p data-bbox="579 710 904 734">Charging by utility and PV energy.</p>  <p data-bbox="579 1045 760 1069">Charging by utility.</p>  <p data-bbox="579 1380 861 1404">PV energy feedback to utility.</p>

		
<p>Fault mode</p>	<p>Fault mode: Errors are caused by inside circuit error or external reasons such as over temperature, output short circuited and so on.</p>	<p>Though the unit is working in fault mode, it could work in bypass mode.</p> 
		<p>No output is supplied.</p> 
		<p>No output is supplied.</p> 

■ Fault Reference Code

There are seven groups about fault code, a fault code consist of group code and number, group code is first and number is last, such as C0.

A: Inverter group fault code

E: Parallel group fault code









B: Battery group fault code





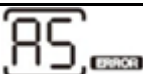

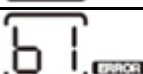
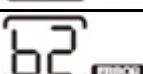







F: Other group fault code

C: PV group fault code

G: Grid group fault code

D: Output group fault code

Fault Code	Fault Event	Icon on
A0	Output short circuited.	
A1	Output voltage is too high.	
A2	Over current or surge	
A3	Over DC voltage in AC output	
A4	Inverter current offset is too high	
A5	Output voltage is too low	
A6	Inverter negative power	
B0	Battery voltage is too high	
B1	DC/DC over current	
B2	DC/DC current offset is too high	
C0	PV over current	
C1	PV over voltage	

C2	PV current offset is too high	
D0	Overload time out	
D1	Op current offset is too high	
E0	Host data loss	
E1	Synchronization data loss	
E2	Incompatible battery type	
E3	Firmware version inconsistent	
E4	Repeat setting external CT at different unit in parallel system	
F0	Over temperature of inverter module	
F1	Over temperature of PV module	
F2	Over temperature of DC/DC module	
F3	Bus voltage is too high	
F4	Bus soft start failed	
F5	Bus voltage is too low	

■ Warning Indicator

There are seven groups about warning code, a warning code consist of group code and number, number is first and group code is last, such as 0C.

A: Inverter group fault code

B: Battery group fault code







C: PV group fault code

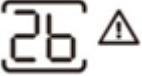
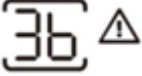

D: Output group fault code

E: Parallel group fault code

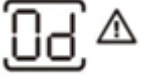
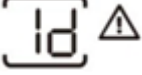
F: Other group fault code

G: Grid group fault code

Warning Code	Warning Event	Audible Alarm	Icon flashing
0B	Battery low	Beep once every second	
1B	Battery is not connected	None	
2B	Battery equalization	None	
3B	Battery low and it isn't up to the setting value of program 06 or 25 of F2 group	Beep twice every 3 seconds	
4B	Lithium battery communication is abnormal	Beep once every 0.5 seconds	
1C	PV energy is too weak	Beep twice every 3 seconds	
0D	Overload	Beep once every 0.5 seconds	
1D	Output power derating	Beep twice every 3 seconds	
0E	CAN communication loss	None	

1E	AC output mode setting is different	None	
2E	Battery voltage detected different	None	
0F	Temperature is too High	Beep three times every second	

Battery Equalization

Equalization function is added into charge controller. It reverses the buildup of negative chemical effects like stratification, a condition where acid concentration is greater at the bottom of the battery than at the top. Equalization also helps to remove sulfate crystals that might have built up on the plates. If left unchecked, this condition, called sulfation, will reduce the overall capacity of the battery. Therefore, it's recommended to equalize battery periodically.

1. How to Apply Equalization Function

You must enable battery equalization function in monitoring LCD setting program 33 first. Then, you may apply this function in device by either one of following methods:

1. Setting equalization interval in program 37.
2. Active equalization immediately in program 39.

2. When to Equalize

In float stage, when the setting equalization interval (battery equalization cycle) is arrived, or equalization is active immediately, the controller will start to enter Equalize stage.

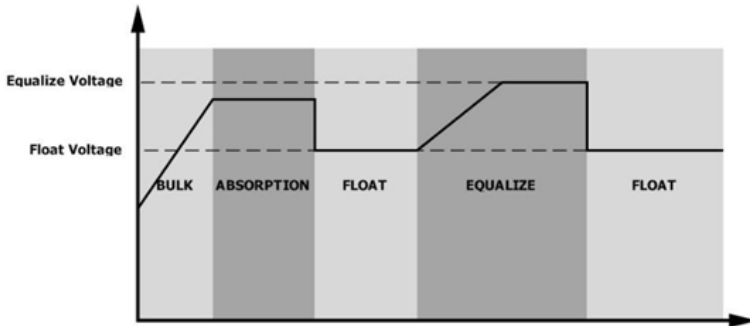

3. Equalize charging time and timeout

In Equalize stage, the controller will supply power to charge battery as much as possible until battery voltage raises to battery equalization voltage. Then, constant-voltage regulation is applied to maintain battery voltage at the battery equalization voltage. The battery will remain in the Equalize stage until setting battery equalized time is arrived.

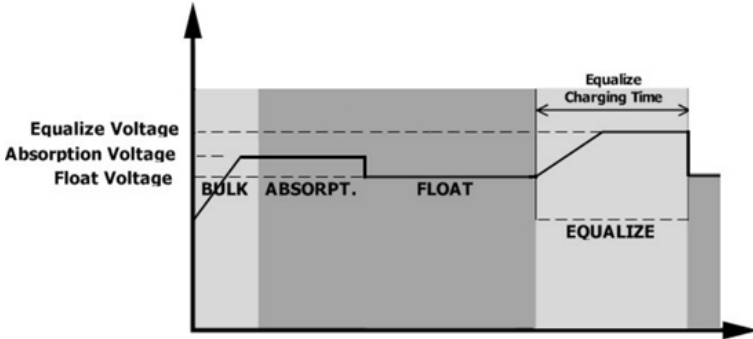

However, in Equalize stage, when battery equalized time is expired and battery voltage doesn't rise to battery equalization voltage point, the charge controller will extend the battery equalized time until battery voltage achieves battery equalization voltage. If battery voltage is still lower than battery equalization voltage when battery equalized timeout setting is over, the charge controller will stop equalization and return to float stage.

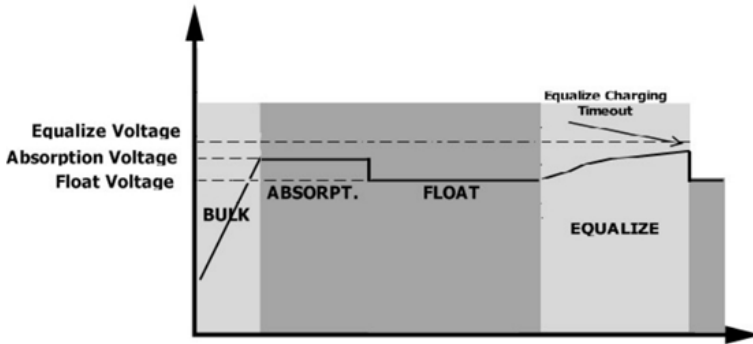

Setting For Lithium Battery

■ Lithium Battery Connection

If choosing lithium battery for the inverter, you are allowed to use the lithium battery only which we have configured. There're two connectors on the lithium battery, RS485 port of BMS and power cable.

Please follow below steps to implement lithium battery connection:

1. Assemble battery terminal based on recommended battery cable and terminal size (same as Lead acid, see section Lead-acid Battery connection for details).
2. Connect the end of RS485 port of battery to BMS(RS485) communication port of inverter.

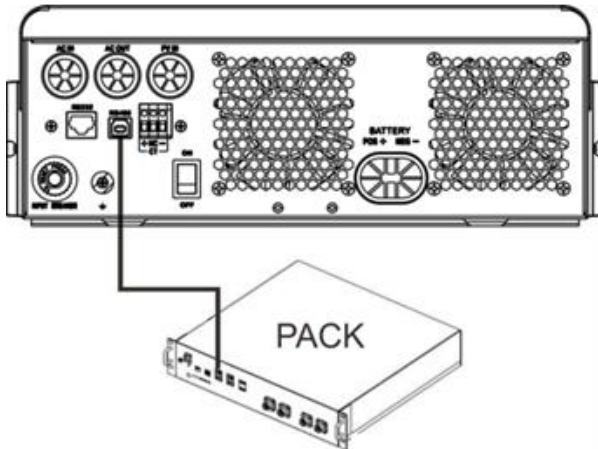

Lithium battery communication and setting

if choosing lithium battery, make sure to connect the BMS communication cable between the battery and the inverter. This communication cable delivers information and signal between lithium battery and the inverter. This information is listed below:

1. Re-configure charging voltage, charging current and battery discharge cut-off voltage according to the lithium battery parameters.
2. Have the inverter start or stop charging according to the status of lithium battery.

Connect the end of RS485 of battery to RS485 communication port of inverter

Make sure the lithium battery RS485 port connects to the inverter is Pin to Pin, the communication cable is inside of package and the inverter RS485 port pin assignment shown as below:

Pin number	RS485 Port	Wire color
PIN1	RS485-B	Red
PIN2	RS485-A	White
PIN3	GND	Green
PIN4	GND	Yellow
PIN5	NC	NC

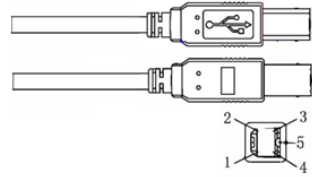

■ Setting for PYLON US2000 lithium battery

1. PYLONTECH US2000 lithium battery setting:

Dip Switch: There are 4 Dip Switches that sets different baud rate and battery group address. If switch position is turned to the “OFF” position, it means “0”. If switch position is turned to the “ON” position, it means “1”.

Dip 1 is “ON” to represent the baud rate 9600.

Dip 2, 3 and 4 are reserved for battery group address.

Dip switch 2, 3 and 4 on master battery (first battery) are to set up or change the group address.

NOTE: “1” is upper position and “0” is bottom position.

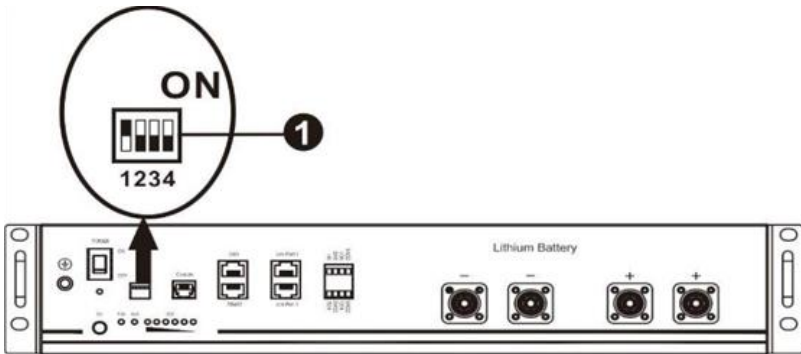

2. Process of install

Step 1. Use the RS485 cable to connect inverter and Lithium battery.

Step 2. Switch on Lithium battery.

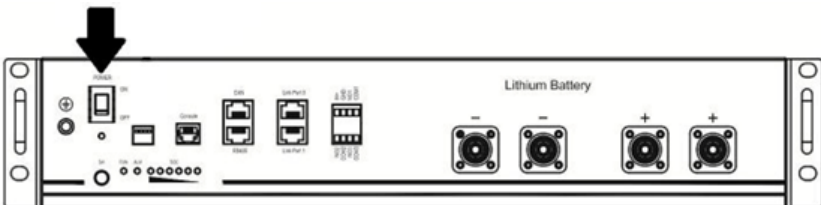

Step 3. Press more than three seconds to start Lithium battery, power output ready.

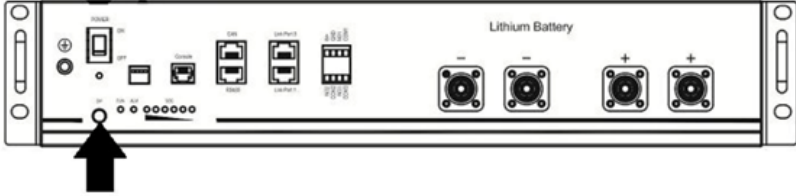

Step 4. Turn on the inverter.

Step 5. Be sure to select battery type as “Li2” in LCD program 5.

If communication between the inverter and battery is successful, the battery icon **LI** on LCD display will light

■ Setting for lithium battery without communication

This suggestion is used for lithium battery application and avoid lithium battery BMS protection without communication, please finish the setting as follow:

1. Before starting setting, you must get the battery BMS specification:

- A. Max charging voltage
- B. Max charging current
- C. Discharging protection voltage

2. Set battery type as “USE” (user-defined)

01 (F2)	Battery type	AGM (default)	Flooded
		User-Defined	If “User-Defined” is selected, battery charge voltage and low DC cut-off voltage can be set up in program 03, 04 and 07 of F2.

3. Set C.V voltage as Max charging voltage of BMS-0.5V.

03 (F2)	Bulk charging voltage (C.V voltage)	56.4 ^v
		If self-defined is selected in program 01 (F1), this program can be set up. Setting range is from 48.0V to 62.0V.

4. Set floating charging voltage as C.V voltage.

04 (F2)	Floating charging voltage	54.0 ^v
		If self-defined is selected in program 01 (F1) , this program can be set up. Setting range is from 48.0V to 62.0V

5. Set Low DC cut-off voltage \geq discharging protection voltage of BMS+2V.

07 (F2)	Low DC cut-off voltage	default setting: 42.0V 42.0 ^v
		If self-defined is selected in program 01 (F1) , this program can be set up. Setting range is from 40.0V to 54.0V. Low DC cut-off voltage will be fixed to setting value no matter what percentage of load is connected.

6. Set Max charging current which must be less than the Max charging current of BMS.

08(F2)	Maximum charging current: To configure total charging current for solar and utility chargers. (Max. charging current = utility charging current + solar charging current)	60A (default) 060 ^A
		If selected, acceptable charging current range will be within 1-100A, but it shouldn't be less than the AC charging current (program 09 (F2))

7. Setting voltage point back to utility source when selecting "SBU priority" in program

01(F1).

The setting value must be \geq Low DC cut-off voltage+1V, or else the inverter will have a warning as battery voltage low.

05(F2)	Setting voltage point back to utility source when selecting "SBU priority" in program 01(F1).	46.0 ^v
--------	---	-------------------

Remark:

1. You'd better to finish setting without turn on the inverter (just let the LCD show, no output);
2. When you finish setting, please restart the inverter.

Specifications

■ **Table 1 Line Mode Specifications**

INVERTER MODEL	POW-HVM5.5M
Input Voltage Waveform	Sinusoidal (utility or generator)
Nominal Input Voltage	230Vac
Low Loss Voltage	170Vac±7V (UPS); 90Vac±7V (Appliances)
Low Loss Return Voltage	180Vac±7V (UPS); 100Vac±7V (Appliances)
High Loss Voltage	280Vac±7V
High Loss Return Voltage	270Vac±7V
Max AC Input Voltage	300Vac
Nominal Input Frequency	50Hz / 60Hz (Auto detection)
Low Loss Frequency	40±1Hz
Low Loss Return Frequency	42±1Hz
High Loss Frequency	65±1Hz
High Loss Return Frequency	63±1Hz
Output Short Circuit Protection	Line mode: Circuit Breaker; Battery mode: Electronic Circuits
Efficiency (Line Mode)	>95% (Rated R load, battery full charged)
Transfer Time	10ms typical (UPS); 20ms typical (Appliances)
Output power derating: When AC input voltage drops to 95V or 170V depending on models, the output power will be derated.	<p>The graph illustrates the output power derating characteristics. The vertical axis represents Output Power, and the horizontal axis represents Input Voltage. Key points on the graph include: <ul style="list-style-type: none"> At 90V input voltage, the output power is at 50% of the rated power. Between 90V and 170V, the output power increases linearly from 50% to 100% (Rated Power). From 170V to 280V, the output power remains constant at the Rated Power level. </p>

Table 2 Inverter Mode Specifications

INVERTER MODEL	POW-HVM5.5M
Rated Output Power	5.5KVA/5.5KW
Max AC Feedback Power	5.5KVA/5.5KW
Output Voltage Waveform	Pure Sine Wave
Output Voltage Regulation	230Vac±5%
Output Frequency	60Hz or 50Hz
Peak Efficiency	94%
Overload Protection	5s@≥140% load; 10s@100%~140% load
Surge Capacity	2* rated power for 5 seconds
Nominal DC Input Voltage	48Vdc
Cold Start Voltage	46.0Vdc

Table 3 Charge Mode Specifications

Utility Charging Mode		
INVERTER MODEL		POW-HVM5.5M
Charging Current (Max) (AC+PV)		100Amp
AC Charging Current (Max)		60Amp (@ VI/P=230Vac)
Bulk Charging Voltage	Flooded Battery	58.4Vdc
	AGM / Gel Battery	56.4Vdc
Floating Charging Voltage		54Vdc
Overcharge Protection		62Vdc
Charging Algorithm		3-Step
Charging Curve	<p>The graph plots Battery Voltage (per cell) on the left y-axis and Charging Current (%) on the right y-axis against Time on the x-axis. The voltage curve (black line) rises linearly during the Bulk phase, reaches a plateau at 2.43Vdc (2.35Vdc) during the Absorption phase, and then slightly drops to a floating level during the Maintenance phase. The current curve (red line) is constant at 100% during the Bulk phase, then decays exponentially during the Absorption phase, and remains at a low level during the Maintenance phase. Key time intervals T0 and T1 are marked, with a note: T1 = 10* T0, minimum 10mins, maximum 8hrs.</p>	
Solar Input		
INVERTER MODEL		POW-HVM5.5M
Rated Power		5000W
Max. PV Array Open Circuit Voltage		500Vdc
PV Array MPPT Voltage Range		120Vdc~450Vdc
Max. MPPT Charge Current		100A
Max. Input Current		18A

Table 4 General Specifications

INVERTER MODEL	POW-HVM5.5M
Safety Certification	CE
Operating Temperature Range	-10°C to 55°C
Storage temperature	-15°C~ 60°C
Humidity	5% to 95% Relative Humidity (Non-condensing)
Dimension(D*W*H), mm	448x315x122
Net Weight, kg	11

Trouble Shooting

Problem	LCD/LED/Buzzer	Explanation / Possible cause	What to do
Unit shuts down automatically during startup process.	LCD/LEDs and buzzer will be active for 3 seconds and then complete off.	The battery voltage is too low	<ol style="list-style-type: none"> 1. Re-charge battery. 2. Replace battery.
No response after power on.	No indication.	<ol style="list-style-type: none"> 1. The battery voltage is far too low. 2. Battery polarity is connected reversed. 	<ol style="list-style-type: none"> 1. Check if batteries and the wiring are connected well. 2. Re-charge battery. 3. Replace battery.
Mains exist but the unit works in battery mode.	Input voltage is displayed as 0 on the LCD and green LED is flashing.	Input protector is tripped	Check if AC breaker is tripped and AC wiring is connected well.
	Green LED is flashing.	Insufficient quality of AC power. (Shore or Generator)	<ol style="list-style-type: none"> 1. Check if AC wires are too thin and/or too long. 2. Check if generator (if applied) is working well or if input voltage range setting is correct. (UPSti Appliance)
	Green LED is flashing.	Set "SBU" or "SUB" as the priority of output source.	Change output source priority to Utility first.
When the unit is turned on, internal relay is switched on and off repeatedly.	LCD display and LEDs are flashing	Battery is disconnected.	Check if battery wires are connected well.
	Fault code D0	Overload error. The inverter is	Reduce the connected

Buzzer beeps continuously and red LED is on.		overload 110% and time is up.	load by switching off some equipment.
	Fault code A2	Output short circuited.	Check if wiring is connected well and remove abnormal load.
	Fault code F2	Internal temperature of inverter component is over 100°C.	Check whether the air flow of the unit is blocked or whether the ambient temperature is too high.
	Fault code B0	Battery is over-charged.	Return to repair center.
		The battery voltage is too high.	Check if spec and quantity of batteries are meet requirements.
	Fault code A1/A5	Output abnormal (Inverter voltage below than 190Vac or is higher than 260Vac)	1. Reduce the connected load. 2. Return to repair center
	Fault code F3/F4	Internal components failed.	Return to repair center.
	Fault code A2	Over current or surge.	Restart the unit, if the error happens again, please return to repair center.
	Fault code F5	Bus voltage is too low.	
	Fault code A3	Output voltage is unbalanced.	
Another fault code		If the wires is connected well, please return to repair center.	

Parallel Installation Guide

■ Instruction

This inverter can be used in parallel with two different operation modes.

1. Parallel operation in single phase with up to 12 units. The supported maximum output power is 60KW/60KVA.
2. Maximum 12 units work together to support three-phase equipment. 10 units support one phase maximum. The supported maximum output power is 60KW/60KVA and one phase can be up to 50KW/50KVA.

NOTICE

- If this unit is bundled with share current cable and parallel cable, this inverter is default supported parallel operation.

■ Package Contents

In parallel kit, you will find the following items in the package:

Parallel communication cable

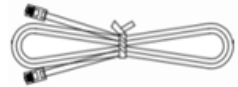

■ Mounting the Unit

When installing multiple units, please follow below chart.

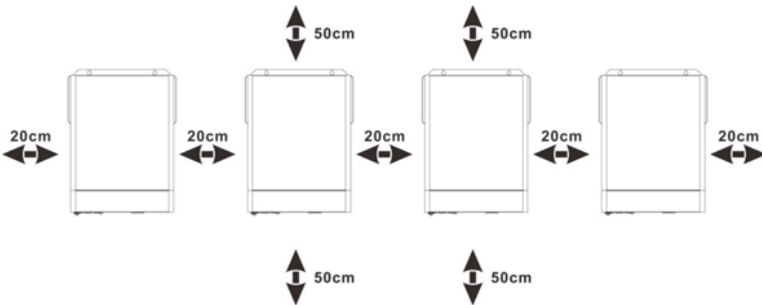

NOTICE

- For proper air circulation to dissipate heat, allow a clearance of approx. 20 cm to the side and approx. 50 cm above and below the unit. Be sure to install each unit in the same level.

■ Wiring Connection

NOTICE

- It's requested to connect to battery for parallel operation.

The cable size of each inverter is shown as below:

● Recommended battery cable and terminal size for each inverter

Model	Wire Size	Cable mm ²	Dimensions		Torque value
			L1 (mm)	L2 (mm)	
5KVA	2AWG	38	3	18	2~ 3 Nm

Stripping Length:

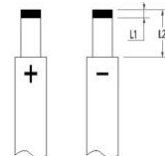

WARNING

- Be sure the length of all battery cables is the same. Otherwise, there will be voltage difference between inverter and battery to cause parallel inverters not working.

● Recommended AC input and output cable size for each inverter

Model	AWG no.	Torque
5KVA	8 AWG	1.4~1.6Nm

You need to connect the cables of each inverter together. Take the battery cables for example: You need to use a connector or bus-bar as a joint to connect the battery cables together, and then connect to the battery terminal. The cable size used from joint to battery should be X times cable size in the tables above. "X" indicates the number of inverters connected in parallel.

Regarding AC input and output, please also follow the same principle.

CAUTION

- Please install the breaker at the battery and AC input side. This will ensure the inverter can be securely disconnected during maintenance and fully protected from over current of battery or AC input. The recommended mounted location of the breakers is shown in the figures in Point 5.

● Recommended breaker specification of battery for each inverter

Model	1 unit*
5KVA	100A/60VDC

*If you want to use only one breaker at the battery side for the whole system, the rating of the breaker should be X times current of 1 unit. "X" indicates the number of inverters connected in parallel.

● **Recommended breaker specification of AC input with single phase**

Model	2 units	3 units	4 units	5 units	6 units	7 units	8 units	9 units	10 units	11 units	12 units
5KVA	100A	150A	200A	250A	300A	350A	400A	450A	500A	550A	600A

NOTICE

Also, you can use 40A breaker (50A for 5KVA) for only 1 unit, and each inverter has a breaker at its AC input.

● **Recommended battery capacity**

Inverter parallel numbers	2	3	4	5	6	7	8	9	10	11	12
Battery Capacity	400AH	600AH	800AH	1000AH	1200AH	1400AH	1600AH	1800AH	2000AH	2200AH	2400AH

WARNING

Be sure that all inverters will share the same battery bank. Otherwise, the inverters will transfer to fault mode.

Communicating with battery BMS in parallel system

1. Only support common battery installation
 2. Use RJ45 cable to connect any one of inverters (no need to connect to a specific inverter) and Lithium battery.
- Simply set this inverter battery type to “Li 2” in LCD program 01(F2). Others should be default value “AGM”.

NOTICE

Make sure only one inverter is connected RJ45 cable and only the one is set as Lithium in LCD program 01(F2).

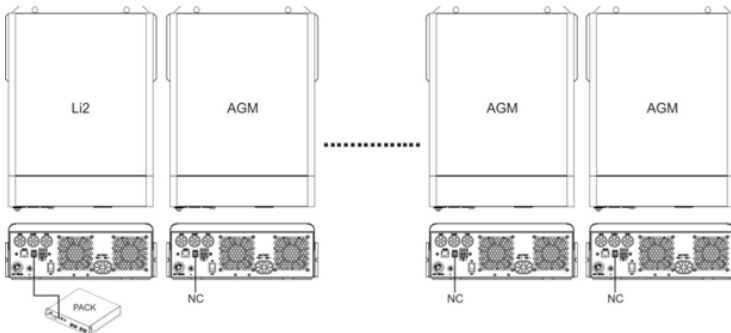

■ Parallel Operation in Single phase

1. External CT is an optional part which is only used in "ZEC" mode as output source priority. Parallel system could work well in other output source priority without installing external CT.
2. One single phase parallel system just needs to be installed one external CT in any one unit which must be finish setting program 12 of F0 group.
3. External CT must be installed in L bus wire.
4. External CT arrow must point to inverter.

Two inverters in parallel:

Power Connection

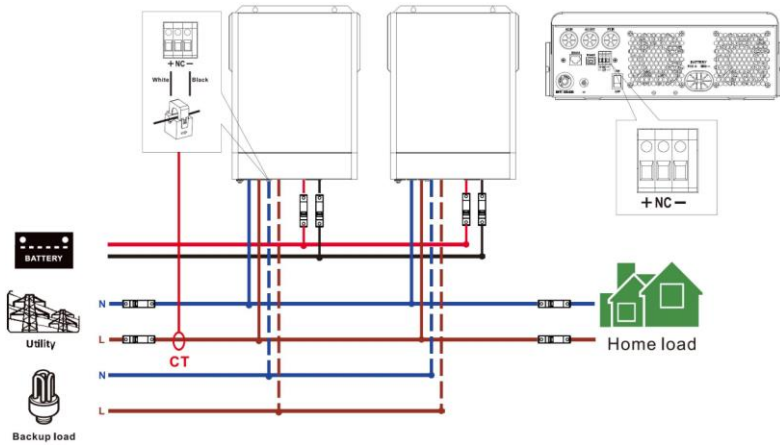

Note: External CT is only installed in one inverter.

Communication Connection



Three inverters in parallel:

Power Connection

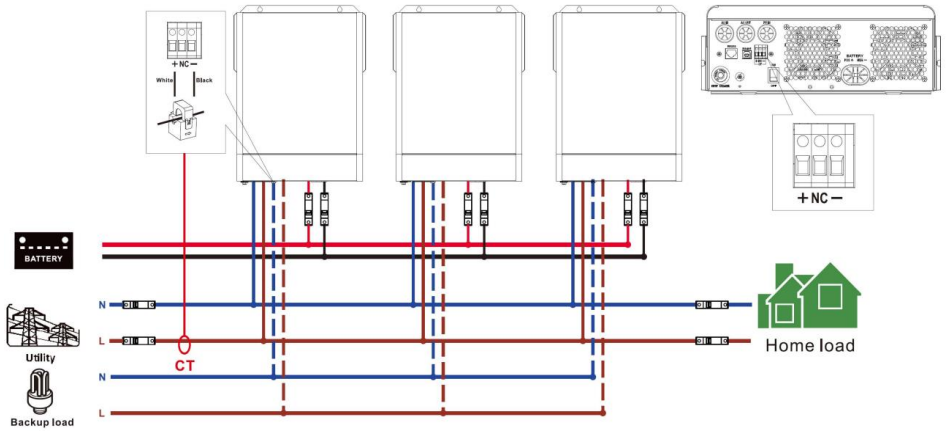

Note: External CT is only installed in one inverter.

Communication Connection

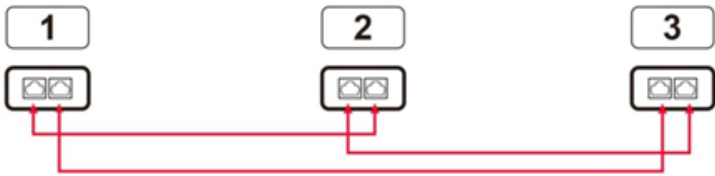

Four inverters in parallel:

Power Connection

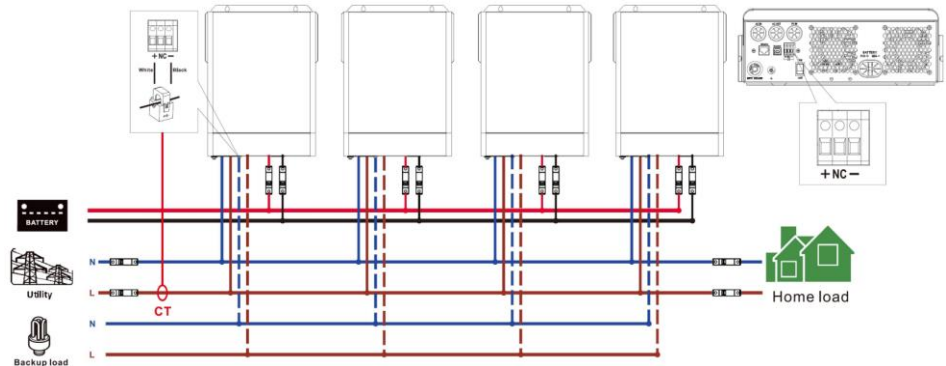

Note: External CT is only installed in one inverter.

Communication Connection



Power Connection

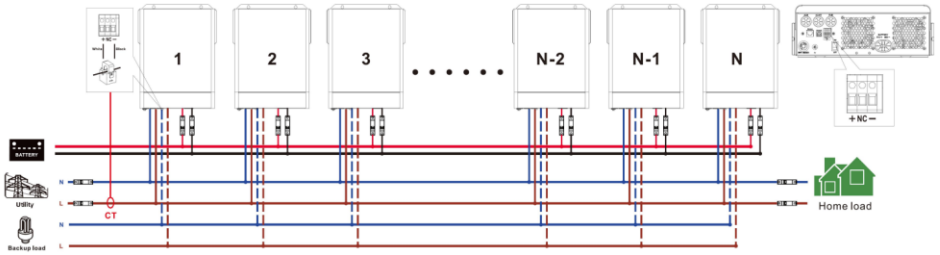

Note: External CT is only installed in one inverter.

Communication Connection



Note: $N_{max}=12$ units.

■ Support 3-phase equipment

1. External CT is an optional part which is only used in "ZEC" mode as output source priority. Parallel system could work well in other output source priority without installing external CT.
2. Every phase(L1/L2/L3) of parallel system needs to be installed one external CT in any one unit which must be finish setting program 12 of F0 group.
3. External CT must be installed in L1/L2/L3 bus wire, so the parallel system need install 3 external CTs.
4. External CT arrow must point to inverter.

One inverter in each phase:

Power Connection

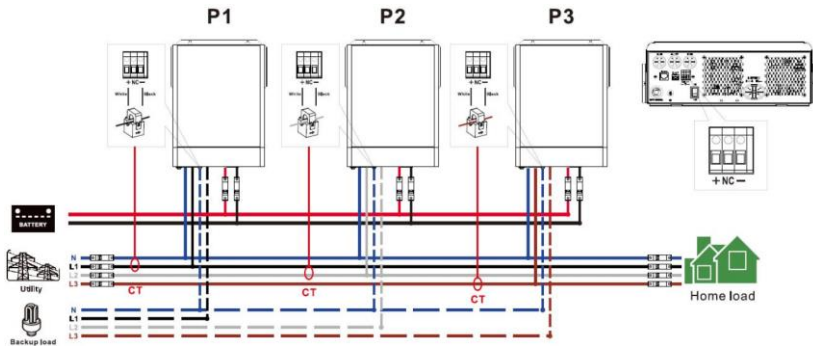

Note: External CT is only installed in one inverter of P1/P2/P3 phase.

Communication Connection

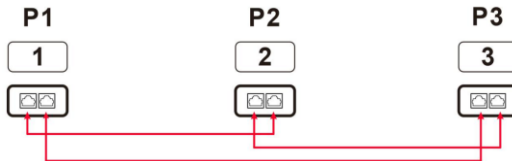

Three inverters in each phase:

Power Connection

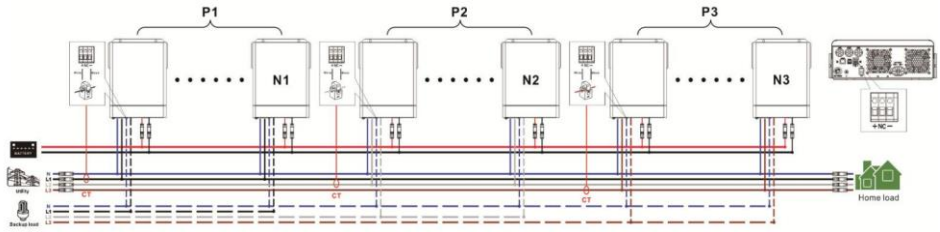

Note: It's up to customer's demand to pick **10** inverters on any phase.

P1: L1-phase, P2: L2-phase, P3: L3-phase.

$N=N1+N2+N3$, $N_{max}=12$ units.

External CT is only installed in one inverter of P1/P2/P3 phase.

$N1_{max}=10$ units is in one phase and one inverter for the other two phases ($N2=N3=1$) :

Power Connection

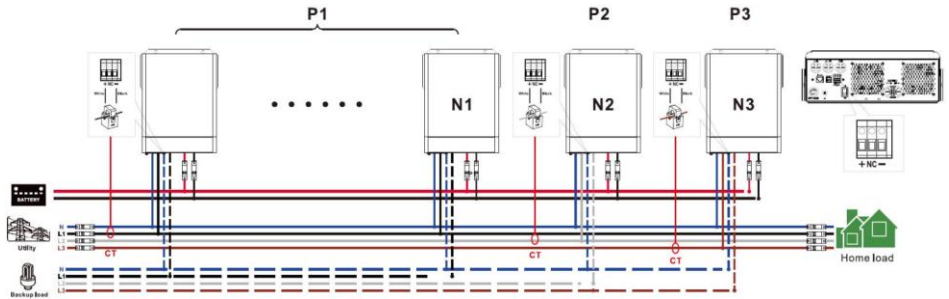

Note: It's up to customer's demand to pick **7** inverters on any phase.

P1: L1-phase, P2: L2-phase, P3: L3-phase.

$N=N1+N2+N3$, $N_{max}=12$ units

External CT is only installed in one inverter of P1/P2/P3 phase.

$N1_{max}=10$ units is in one phase and one inverter for the other two phases ($N2=N3=1$) :

Power Connection

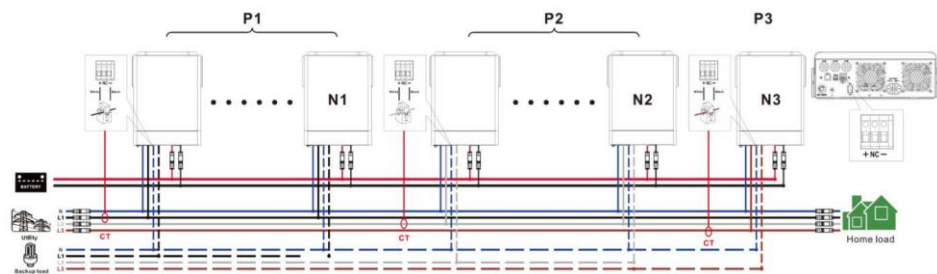

Communication Connection



PV Connection

Please refer to user manual of single unit for PV Connection.

CAUTION

- Each inverter should connect to PV modules separately.

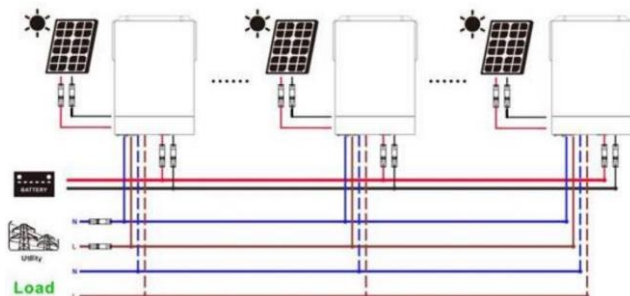

Commissioning

Parallel in single phase

Step 1: Check the following requirements before commissioning:

1. Correct wire connection
2. Ensure all breakers in Line wires of load side are open and each Neutral wires of each unit are connected together.

Step 2: Turn on each unit and set "PAL" in LCD setting program 02(F1) of each unit. And then shut down all units.

NOTICE

- It's necessary to turn off switch when setting LCD program. Otherwise, the setting can not be programmed.

Step 3: Turn on each unit.

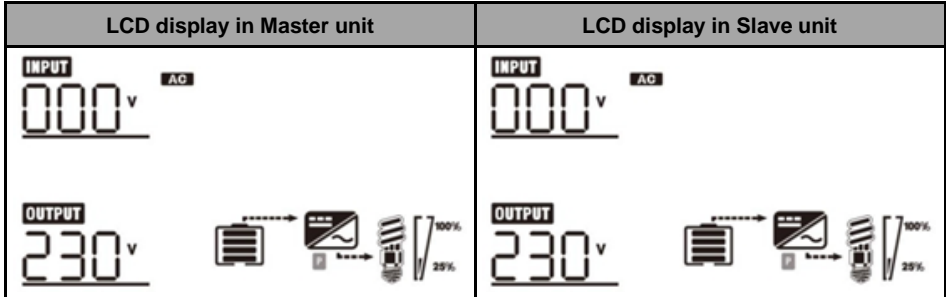

NOTICE

- Master and slave units are randomly defined. If it is master the icon **P** flashes, if it is slave the icon **P** normally on.

Step 4: Switch on all AC breakers of Line wires in AC input. It's better to have all inverters connect to utility at the same time. If detecting AC connection, they will work normally.

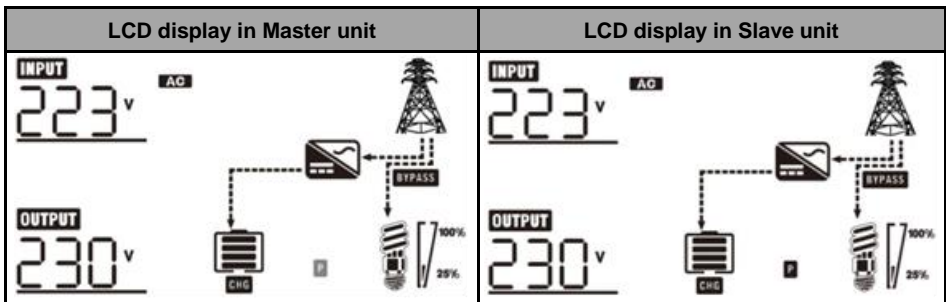

Step 5: If there is no more fault alarm, the parallel system is completely installed.

Step 6: Please switch on all breakers of Line wires in load side. This system will start to provide power to the load.

■ Trouble shooting

Situation		Solution
Fault Code	Fault Event Description	
E0	Host data loss	<ol style="list-style-type: none"> 1. Check if communication cables are connected well and restart the inverter. 2. If the problem remains, please contact your installer.
E1	Synchronization data loss	<ol style="list-style-type: none"> 1. Check if communication cables are connected well and restart the inverter. 2. If the problem remains, please contact your installer.
E2	Incompatible battery type	<ol style="list-style-type: none"> 1. Check the battery type setting to ensure that only the device connected to the BMS in the system is one of Li1 or Li2 or Li3 2. If the problem remains, please contact your installer.
E3	Firmware version inconsistent	<ol style="list-style-type: none"> 1. Update all inverter firmware to the same version. 2. Check the version of each inverter via LCD setting and make sure the CPU versions are same. If not, please contact your installer to provide the firmware to update. 3. After updating, if the problem still remains, please contact your installer.
E4	External CT redundancy	More than one external CT exist in any phase of there phase parallel system

Situation		Solution
Warning Code	Warning Event Description	
0E	CAN communication loss	<ol style="list-style-type: none"> 1. Check if communication cables are connected well and restart the inverter. 2. If the problem remains, please contact your installer.
1E	AC output mode setting is different.	<ol style="list-style-type: none"> 1. Switch off the inverter and check LCD setting program 02(F1). 2. For parallel system in single phase, make sure "PAL" is set on program 02(F1).

		3. If the problem remains, please contact your installer.
2E	The battery voltage of each inverter is not the same.	<p>1. Make sure all inverters share same groups of batteries together.</p> <p>2. Remove all loads and disconnect AC input and PV input. Then, check battery voltage of all inverters. If the values from all inverters are close, please check if all battery cables are the same length and same material type. Otherwise, please contact your installer to provide SOP to calibrate battery voltage of each inverter.</p> <p>3. If the problem still remains, please contact your installer.</p>



POWMr

SHENZHEN HEHEJIN INDUSTRIAL CO.,LTD

Tel/Fax: +86 755-28219903

Email: support@powmr.com

Web: www.powmr.com

Add: Henggang Street, Longgang District, Shenzhen, Guangdong, China