

INSTRUCTIONS

Wixey

NOTE:

REMOTE PLANER READOUT
MODEL Wr550

- Always turn off the power and unplug your machine before installing the Wr550

1- Slide the sensor onto the scale

The sensor can only go on the scale one way. Be sure the pattern on the sensor decal matches the pattern on the scale.

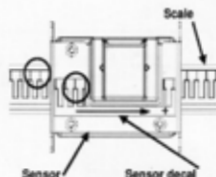

2- Select a mounting position

The WR550 can be mounted to a variety of machines in a number of different ways. Either the scale or the sensor can be mounted to a non moving part of the machine as long as the travel direction of the sensor on the scale is in the proper direction as indicated by the arrow and + sign on the sensor decal. (FIG 1-5).

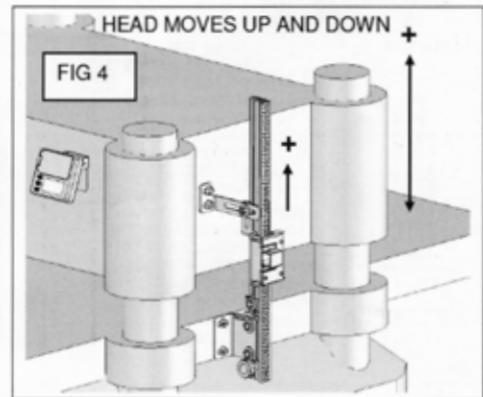
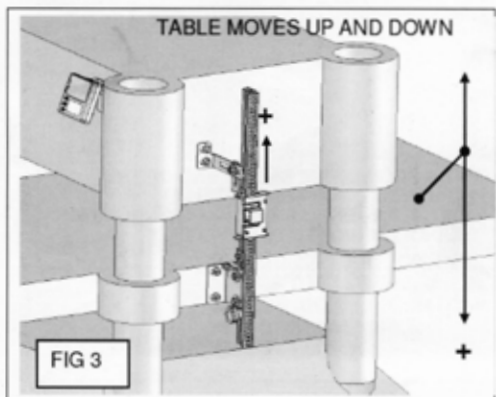
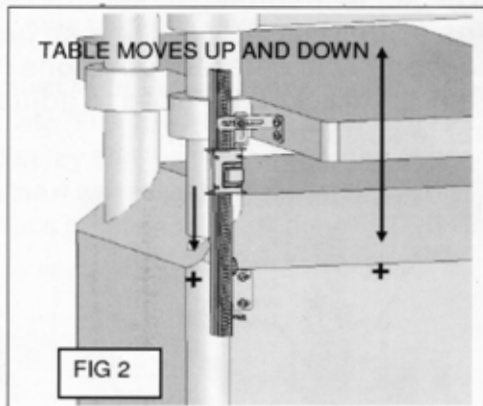
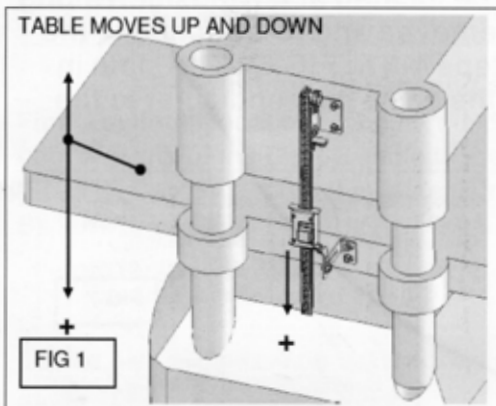

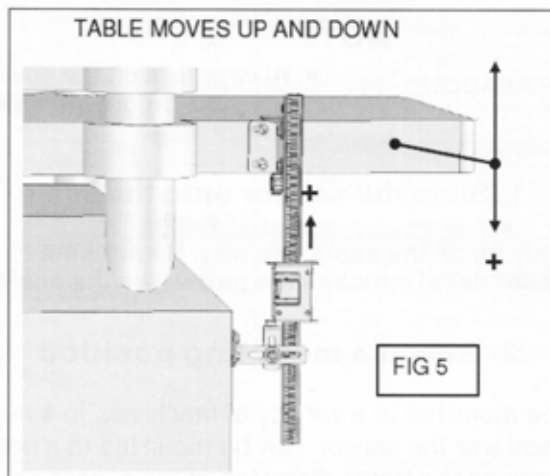

3- Mounting the Scale

The scale mounting assembly can be located at any position along the scale. The "L" bracket can be removed and re-attached to the assembly in different positions (steps 1-3 in FIG 6). The slots in the "L" bracket are used to adjust the scale perpendicular to the table surface (FIG 7).

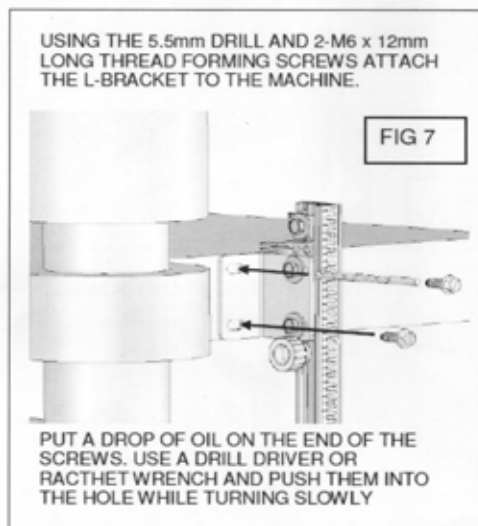
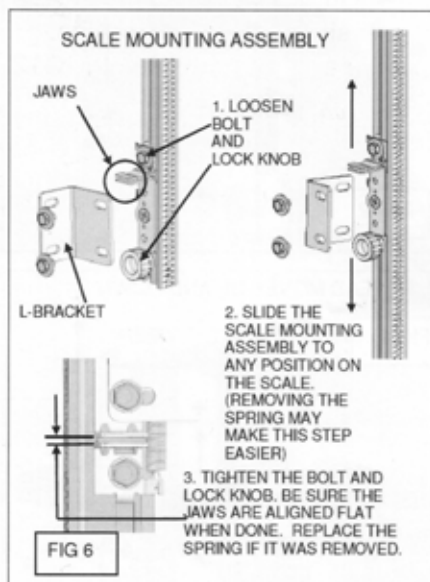

4- Mounting the Magnet Connector

There are 4 tabs on the sensor where the Magnet can attach. There are also a number of possible positions to assemble the Support Arm, Magnet Connector, and Magnet (FIG 8-9).

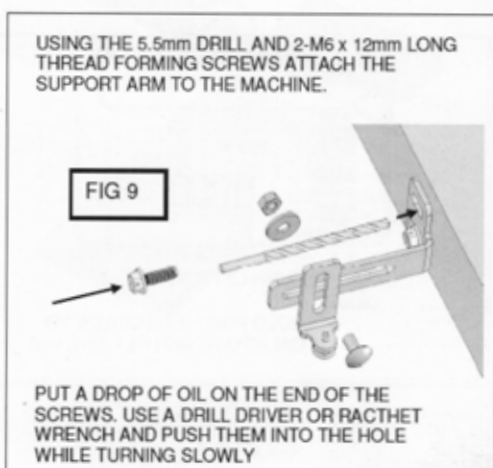
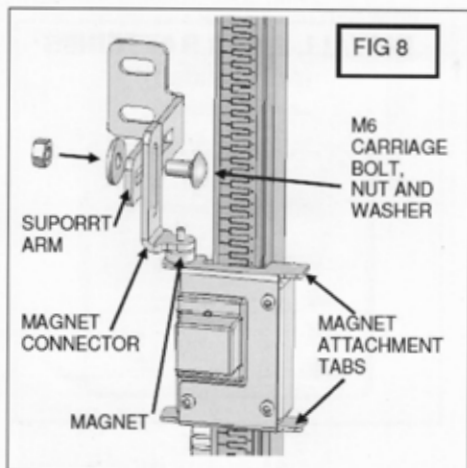

5-Mount the display and connect the Cat 5E cable

Find a suitable location to mount the display (FIG 10). After it is mounted, connect one end of the Cat 5E cable to the display and the other end to the sensor (FIG11). Carefully route the cable using the 4 adhesive backed cable clips (FIG12). Be sure to use a solvent to clean the surface before applying each clip (FIG12).

NOTE: If you purchase a shorter Cat 5E cable to use be sure that is a shielded style noted by the metal encased plug.

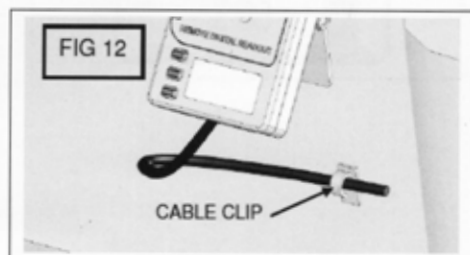
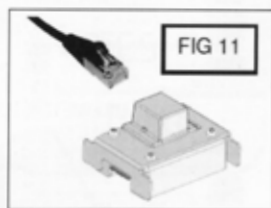
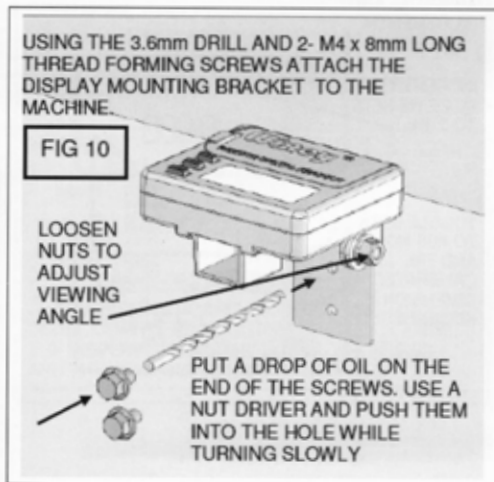

6- Readout Operation

ON/OFF and CALIBRATION



- PUSH MOMENTARILY TO TURN OFF AND ON
- HOLD FOR 3-5 SECONDS TO CALIBRATE AND SET TO 0.000

INSTALL 2 AAA BATTERIES (not included)



IN/MM

ABSOLUTE MEASURING MODE

TOGGLES BETWEEN
INCHES AND MILLIMETERS

INCH MODE



MILLIMETER MODE



ABS/INC

ABSOLUTE
MEASURING
MODE



TOGGLES
BETWEEN
ABSOLUTE AND
INCREMENTAL

INCREMENTAL
MODE RE-SETS
TO 0.000



TOGGLE BACK
TO ABS MODE
AND THE
CALIBRATED
DIMENSION IS
REMEMBERED



7-Calibration

Follow steps 1-7 below to accurately calibrate your readout.

1. RUN A FLAT BOARD 1" THICK OR LESS THROUGH THE MACHINE MAKING SURE THAT MATERIAL IS REMOVE FROM THE ENTIRE TOP SURFACE. DO NOT CHANGE THE SETTING WHEN DONE.

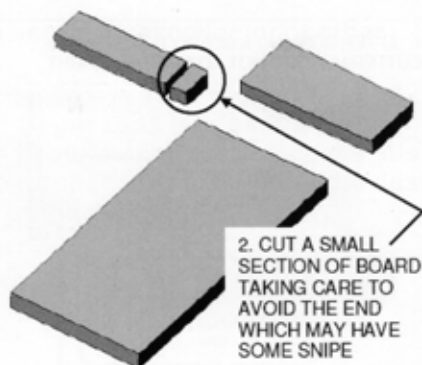
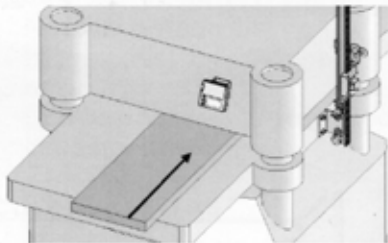

2. CUT A SMALL SECTION OF BOARD TAKING CARE TO AVOID THE END WHICH MAY HAVE SOME SNIPE

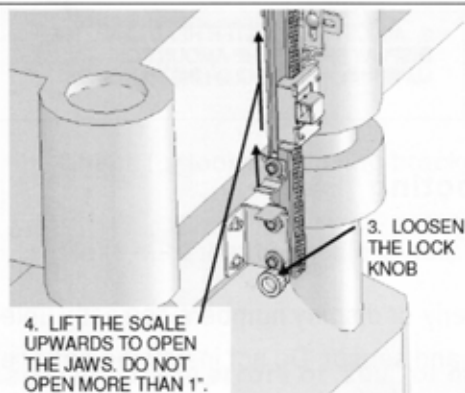

3. LOOSEN THE LOCK KNOB

4. LIFT THE SCALE UPWARDS TO OPEN THE JAWS. DO NOT OPEN MORE THAN 1".

5. PLACE THE CUT PIECE OF BOARD BETWEEN THE JAWS AND MAKE SURE THEY CLAMP FLAT AND TIGHT.

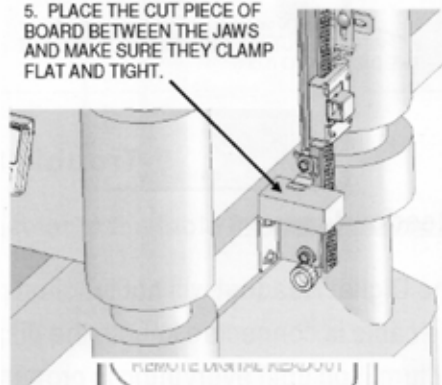

6. PRESS AND HOLD FOR 3-5 SECONDS TO SET TO 0.000



7. REMOVE THE BOARD ALLOWING THE JAWS TO CLOSE COMPLETELY. TIGHTEN THE LOCK KNOB. THE DISPLAY SHOWS THE BOARD THICKNESS AND THE READOUT IS NOW CALIBRATED.

8-Removing an Exact Amount of Material

Follow steps 1-3 below when you want to make a final pass to remove an exact amount of material.

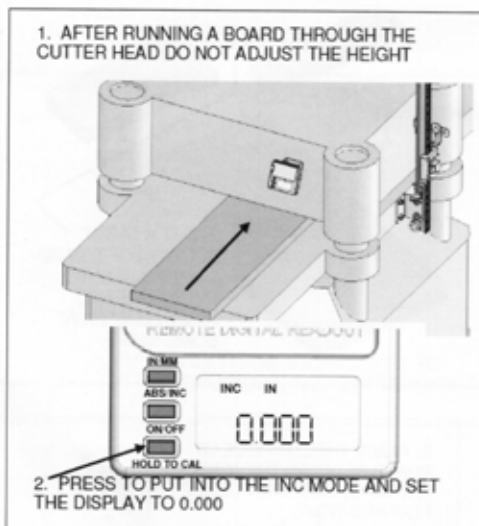

9-Trouble Shooting

Readout issue s

The Digital Readout will not function properly or display numbers correctly unless the cable is connected to both the display and sensor. Do not install the batteries or turn it on until everything is properly connected.

Unstable constantly scrolling numbers

- Insure the sensor is properly installed on the scale.
- Remove the battery, wait 30 seconds and replace it.

Flashing digits, dim, or no display

- Install new batteries.
- Clean batteries and battery contacts.

Frozen display

- Remove the battery, wait 30 seconds and replace it.

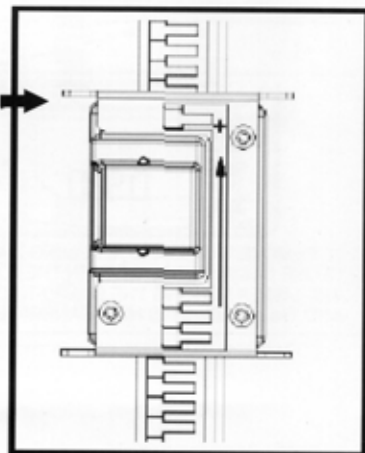

Loses calibration

- Make sure that your machine is properly grounded.
- Route the cable away from electric motors or other electrical controls.
- Check for dirt on the scale or inside the sensor. Remove and clean if needed.
- Check for static discharges from a nearby dust collector or other source

Note: If a static discharge from your finger zaps the readout or a nearby dust collector happens to zap your machine it can cause this error. Make sure the dust collector is properly grounded and the dust port on your saw is grounded to the ground wire inside the dust collector hose.

Accuracy Issues

Small accuracy errors of 1/16" or less

- Be sure the jaws fit tight and flat when in use and when calibrating

- Be sure the lock knob is tight.

- Check for loose or flexing brackets.

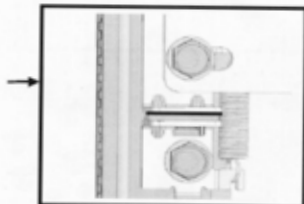

- Make sure that the scale is perpendicular to the table in all planes.

Large accuracy errors of .200" or more

- An error of exactly .200" is a very common error number with these devices or even a multiple of it like .400, .600, 1.200 etc. Usually this only happens when the readout is either moved very quickly (more than 3 feet per second) Follow the same steps outlined in the "**Loses calibration**" section above.

ITEM	PART NO.	DESCRIPTION	QTY.
1	Wr5501	sensor	1
2	WR5502	display	1
3	Wr5503	scale	1
4	WR5504	sensor strip	1
5	WR5508	wedge	1
6	Wr5509	"L" bracket	1
7	WR5510	slide	1
8	Wr5511	lower jaw	1
9	Wr5512	wedge nut	1
10	Wr5513	upper jaw	1
11	WR5514	M6 x 10mm long flat head screw	1
12	WR5515	knob	1
13	WR5516	M6 x 12mm long hex head screw	1
14	WR5517	support arm	1
15	WR5518	magnet mount	1
16	Wr5505	magnet	1

ITEM	PART NO.	DESCRIPTION	QTY.
17	Wr5519	M3 hex nut	1
18	WR5520	M6 flat washer	4
19	WR5521	M6 x 12mm long carriage bolt	1
20	Wr5506	extension spring	1
21	WR5522	5.5mm drill bit	1
22	WR5523	3.6mm drill bit	1
23	WR5524	M6 x 12mm long thread forming screw	4
24	WR5525	cable clip	4
25	WR5526	M6 hex nut	1
26	WR5527	M5 lock nut	2
27	WR5528	M5 x 12mm long carriage bolt	2
28	WR5529	display mounting bracket	2
29	WR5530	M6 x 16mm long hex head screw	2
30	WR5507	Cat 5e shielded cable 2M long	1
31	WR5531	M4 x 8mm long thread forming screw	2

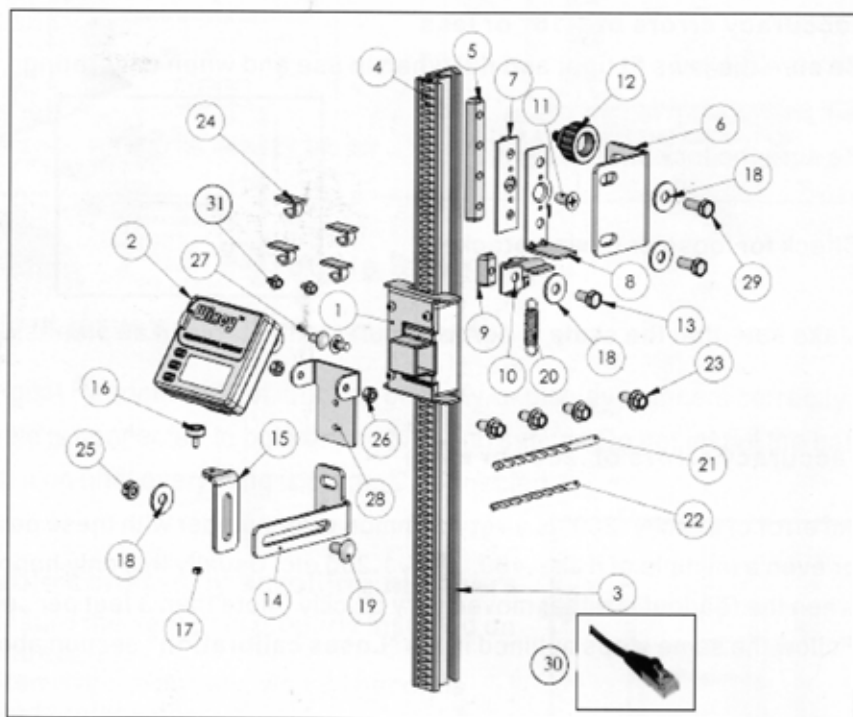

For questions, comments, spare parts, and application examples go to: www.wixey.com