

Planer Knife Setting Jig

Features...

This Planer Knife Setting Jig will help you set your planer knives quickly and accurately. The jig holds the knife firmly in position allowing the use of both hands to tighten the gibs/set screws.

Using the Jig...

Removing and replacing the blades.

1. Refer to Figure 2. Set the jigs on the cutter head as in Figure 2. Read the jigs red scale and the white scale. Record these two numbers.
2. To reset the knives back to their original location, or to set new knives, use the following procedure. With the gibs loosened and the knife setting in the cutter head, set one jig on each end of the knife, positioned as in Figure 2. Make sure the jigs are set at the two numbers recorded in Step #1. Tighten the jig lock screw (Part 7, Figure 2), then tighten the gib/knife lock screws.

Setting the knives to a manufacturers specification.

1. Refer to Figure 1. The jigs must be indexed to your cutter head before setting knives to a known height. To index the jigs, set the jigs on the cutter head as in Figure 1, making sure the jig bases (A & C, Figure 1) are not touching the knives and are resting on the cutter head. Screw the micrometer adjuster (Part 1, Figure 1) down (clockwise) until the magnetic head (B) touches the cutter head. Read the jigs red and white scales and record these two numbers.
2. With the gibs/blade set screws loosened, set one jig on each end of the knife to be set, positioned as in Figure 2. Make sure that both jigs are set to the numbers recorded from the indexing step. Turning the barrel of the jig (Part 2, Figure 2) clockwise raises the knife, counter clockwise lowers the knife. Each full revolution of the jig barrel will move the knife 0.060". When the correct

knife height is obtained, tighten the jig lock screw (Part 7, Figure 2), then tighten the gib/knife lock screws.

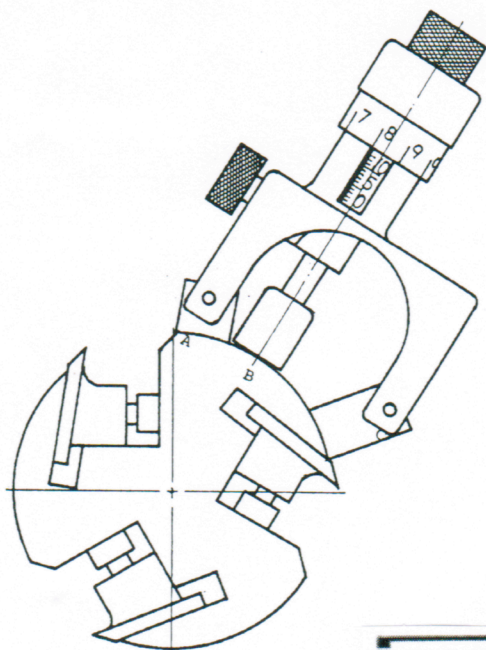

Fig.1

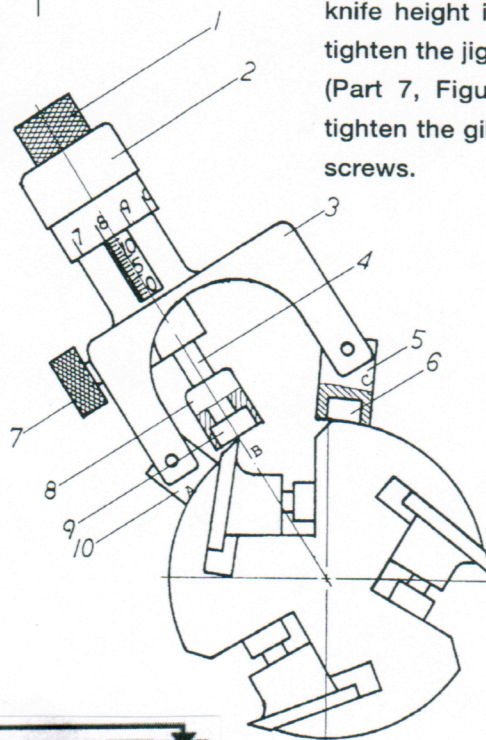

Fig.2

INFINITY
CUTTING TOOLS