

Steelcase

Please & Please Air

User Guide

Ghid de utilizare

Guide d'utilisation

Bedienungsanleitung

Gebruiksaanwijzing

Guida per l'utilizzatore

Instrucciones de uso

Guia de utilização

РУКОВОДСТВО ДЛЯ ПОЛЬЗОВАТЕЛЯ

دليل المستخدم

Steelcase Please Eco-Smart

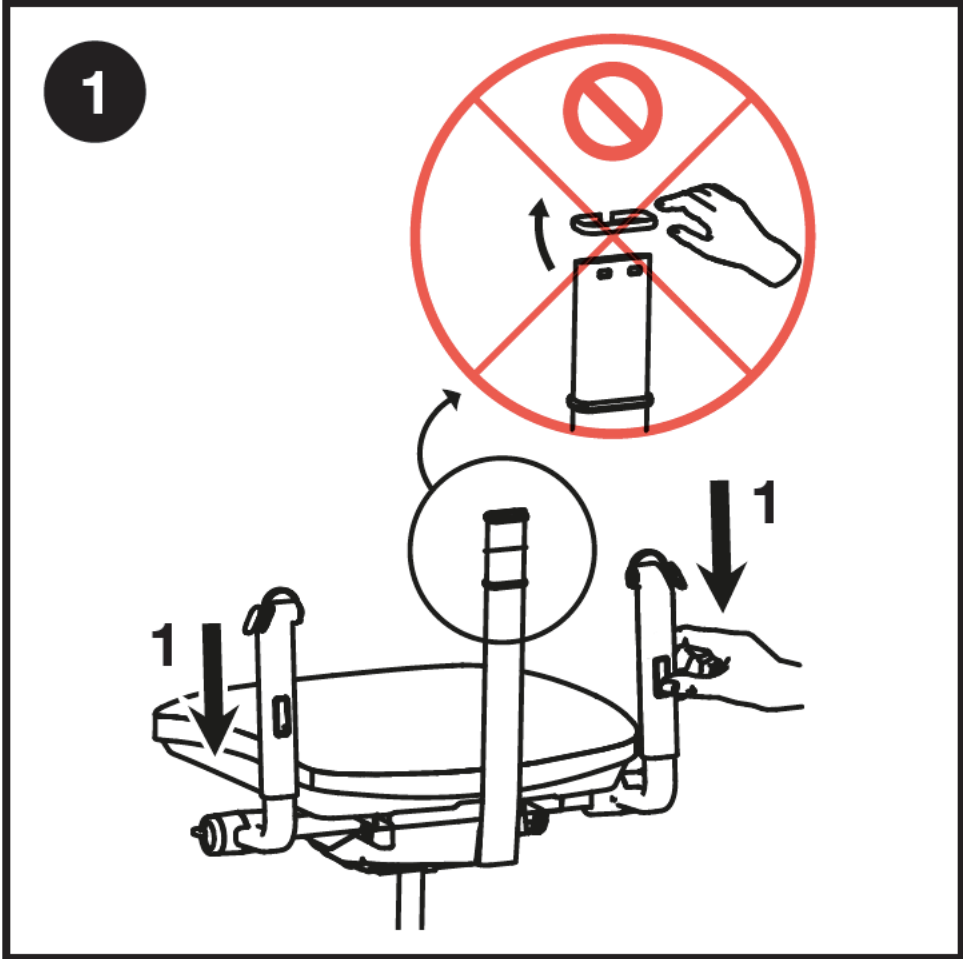

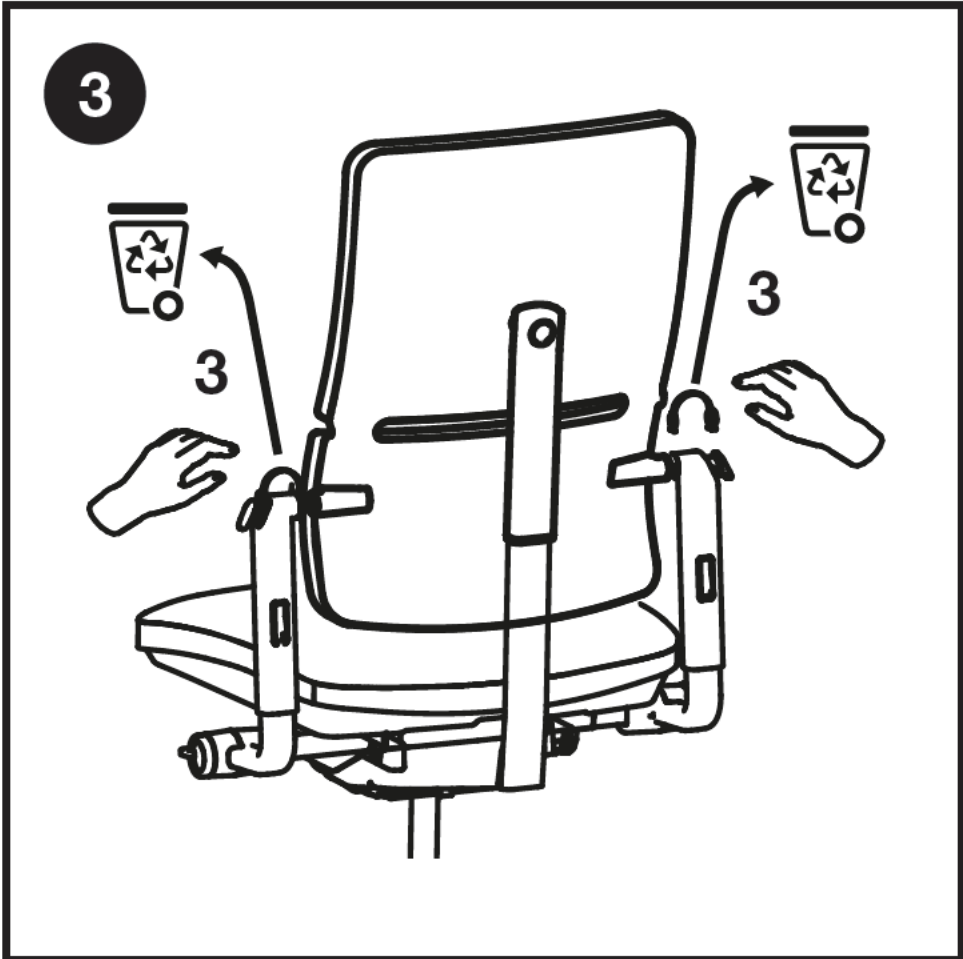
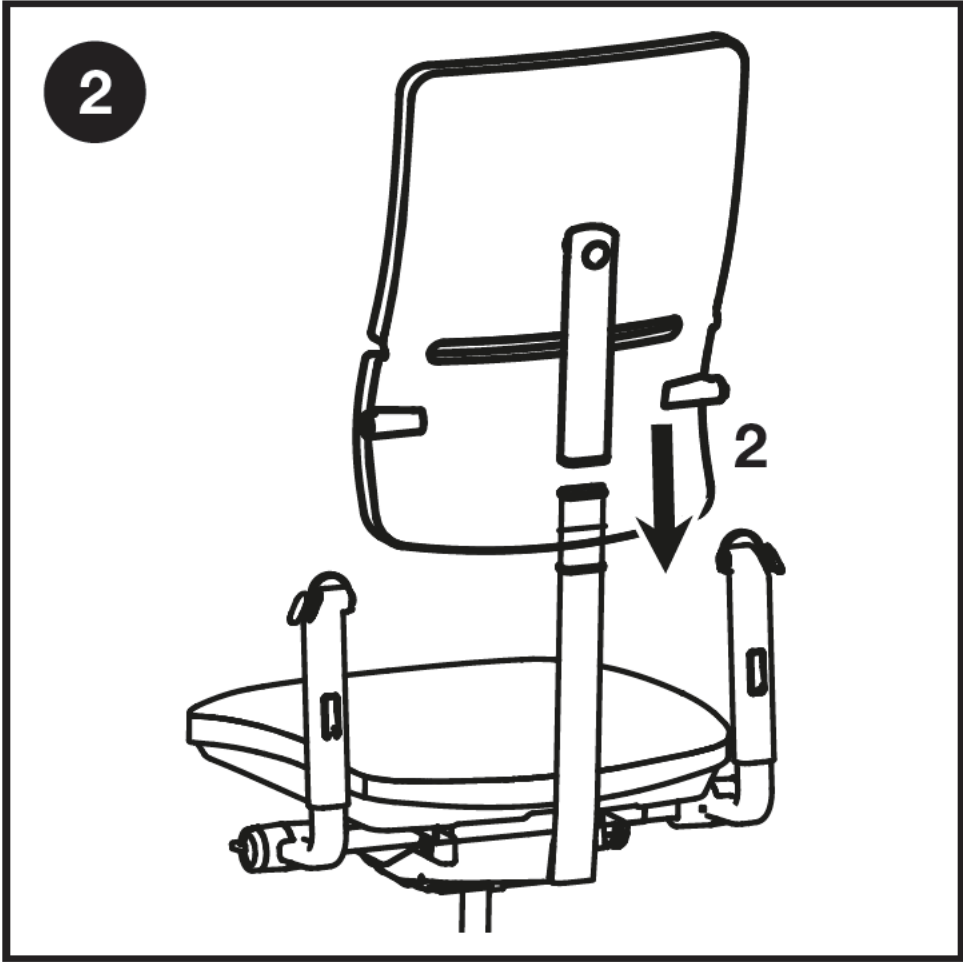

4

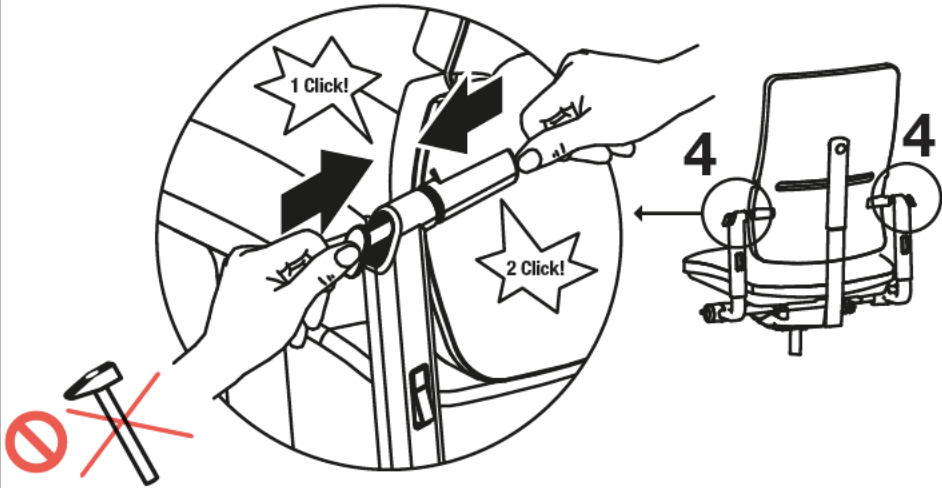

5

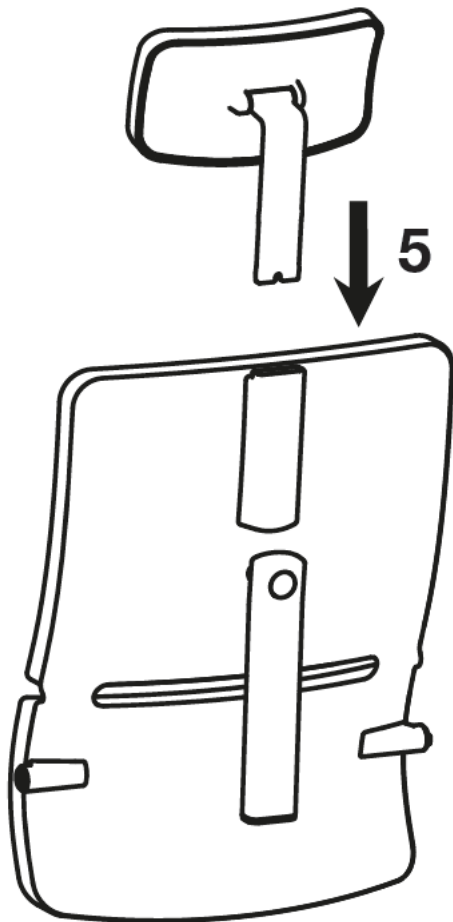

Please

Lumbar tilt tension

Tensiunea de înclinare lombară
Tension lombaire
Härteeinstellung des Lumbalbereichs
Lendensteun
Tension lombare
Tensión lumbar
Tensão lombar
Сила натяжения нижнего (поясничного) отдела спинки
ضغط إمالة أسفل الظهر

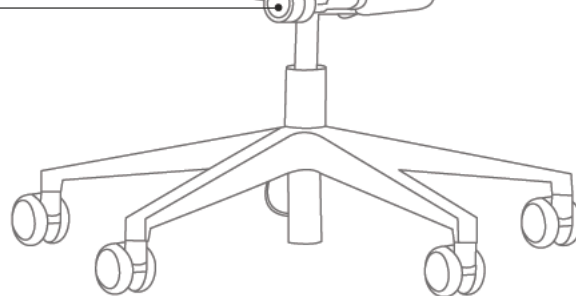
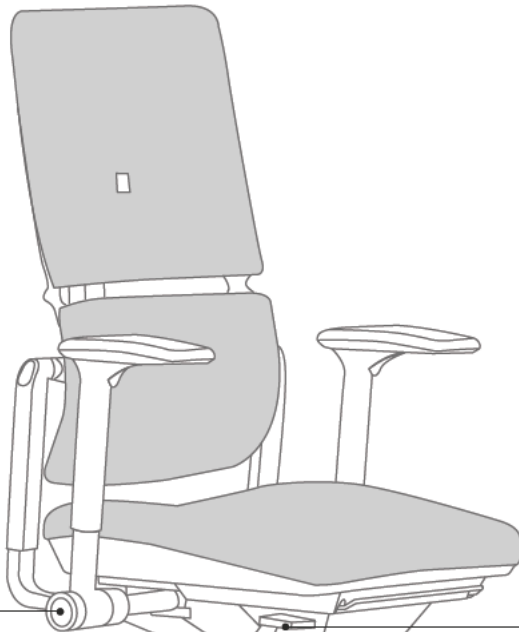

Tilt tension

Tensiunea de înclinare
Tension de basculement
Härteeinstellung der Rückenlehne
Neiging van de rugleuning
Tensione di oscillazione
Tensión de basculación
Tensão de baculação
Сила натяжения верхнего отдела спинки
ضغط الإمالة

Seat height

Înălțimea șezutului
Hauteur d'assise
Sitzhöhe
Zithoogte
Altezza del sedile
Altura del asiento
Altura do assento Регулировка
высоты сиденья
ارتفاع المقعد

Seat depth

Adâncimea șezutului
Profondeur d'assise
Sitztiefe
Zitdiepte
Profondità del sedile
Profundidad del asiento
Profundidade do assento
Регулировка глубины сиденья
عمق المقعد

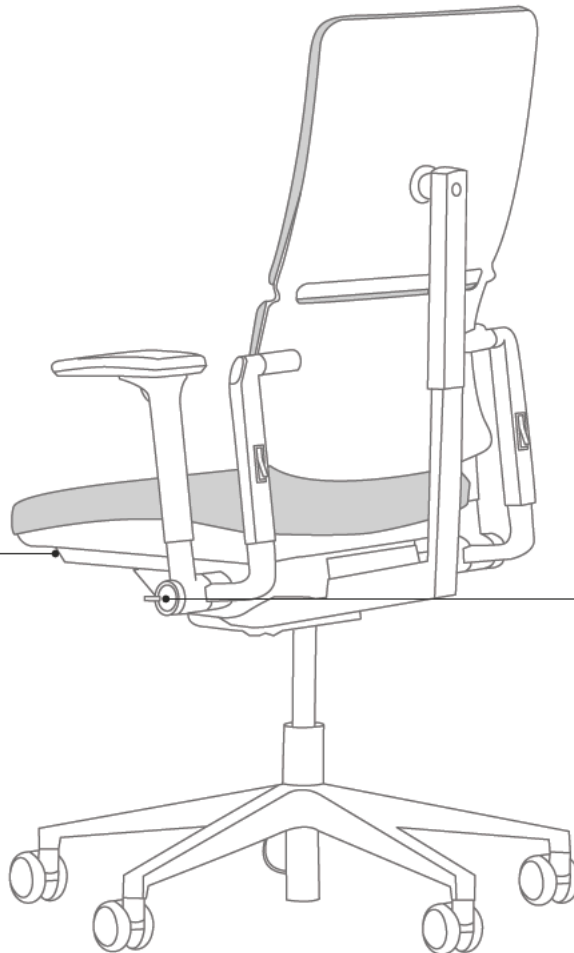

Variable back stop / Tilt limiter

Limitatorul de înclinare
Limiteur de basculement
Begrenzung der Rückenlehne
Neigheokbegrenzer van de rugleuning
Limitatore di basculamento
Limitador de basculación
Limitador de basculação
Ограничитель откидывания спинки
سند ظهر متحرك \ محدد الإمالة

Steelcase Please Air Eco-Smart

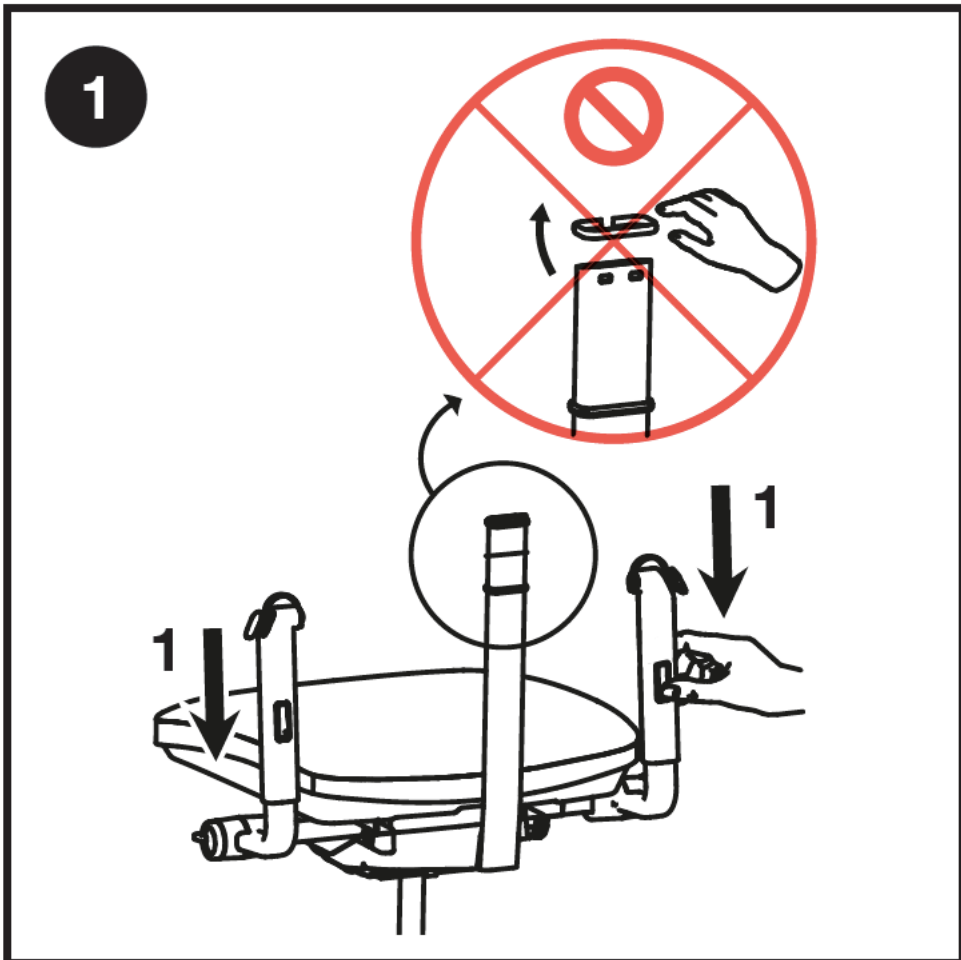

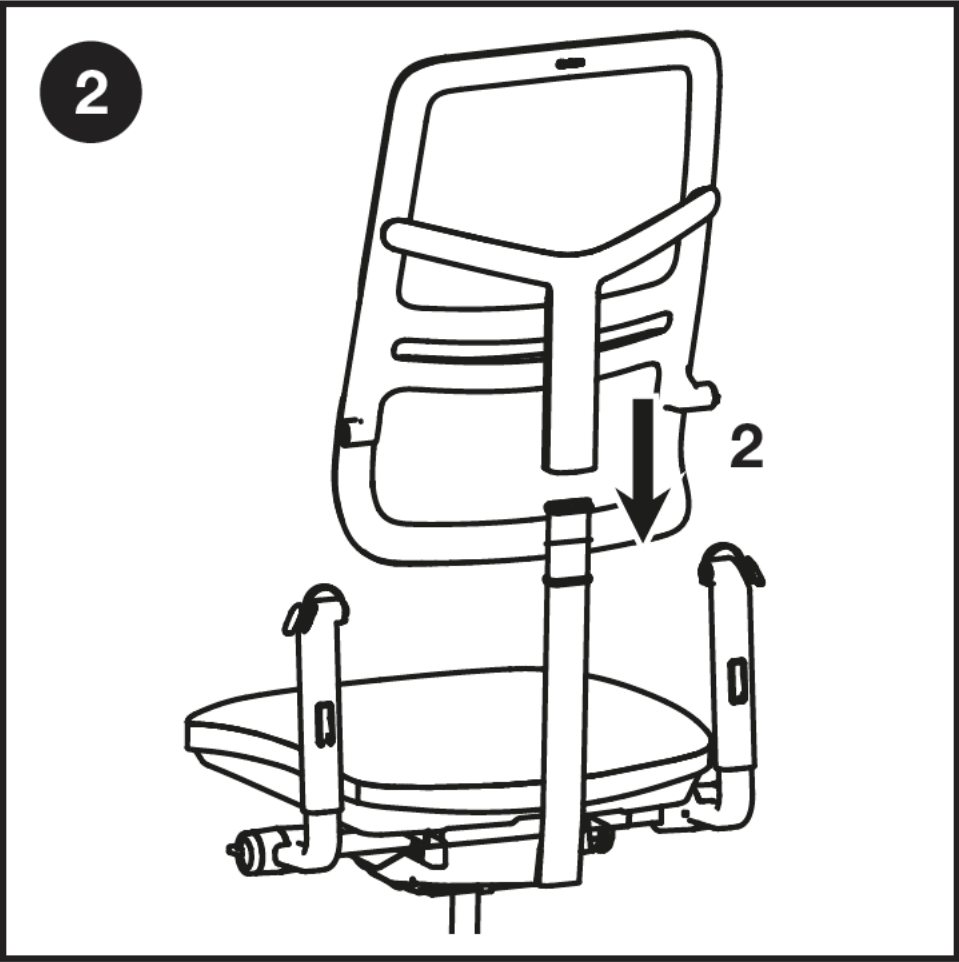

4

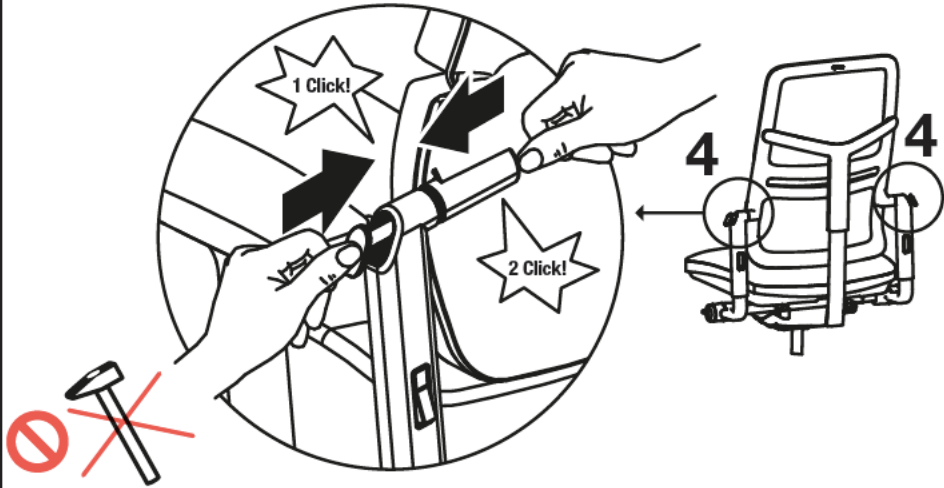

Please Air

Armrest height, depth, pivot and width

Înălțimea, adâncimea, pivotul și lățimea cotierei

Hauteur, profondeur, largeur et angle des accotoirs

Höhen, breiten, tiefen und winkelverstellbare armlehnen

Hoogte, breedte, hoek en diepte van de armleuningen

Altezza, apertura, rotazione e profondità dei braccioli

Altura, profundidad, ángulo y anchura de los brazos

Altura, largura, rotação e profundidade dos braços

Высота, ширина, вращение, глубина регулируемых подлокотников

ارتفاع مسند الذراع والحواف والمحور



Back height

Înălțimea spătarului

Hauteur du dossier

Höhe der Rückenlehne

Hoogte van de rugleuning

Altezza schienale

Altura del respaldo

Altura da costa

Регулировка высоты спинки

ارتفاع الظهر

Please Controls

BACKREST

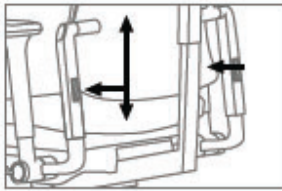

Back height

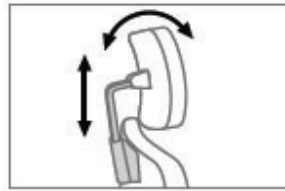

Headrest height and pivot

SEAT

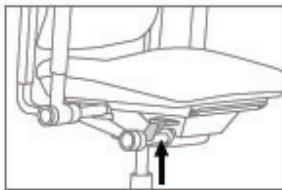

Seat height

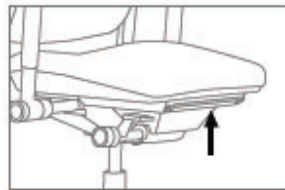

Seat depth

MECHANISM

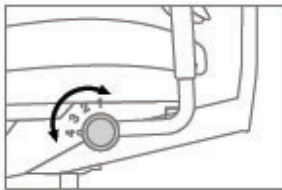

Variable back stop /
Tilt limiter

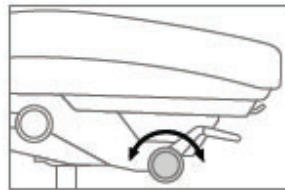

Tilt tension

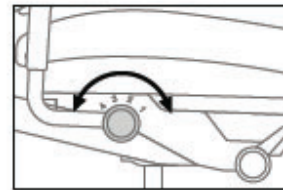

Lumbar tilt tension

ARMRESTS

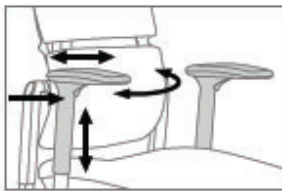

Armrest height, depth,
pivot and width

CASTORS

The choice of castors depends upon the type of flooring the chair will be used on - for hard floors (such as stone, wood, laminate, linoleum etc) select a soft castor. On soft flooring (carpet etc) select a hard castor.

WARRANTY

Please be aware that the product should be used as an office work chair only; any other use can be dangerous for your own safety. The standard task chair is tested to EN 1335-1,2 (normal 8 hour day by persons weighing up to 110 Kgs). For replacement of your chair's adjustable gas lift, only qualified persons (Steelcase staff and dealer engineers) can service the product. Fabrics/Warranty : for any basic advice for taking care of your chair and information concerning general warranties, please check on the website or the Steelcase dealer where you purchased your chair.

Ajustări pentru Please & Please Air

SPĂTAR

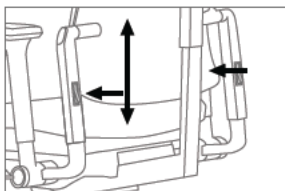

Înălțimea spătarului

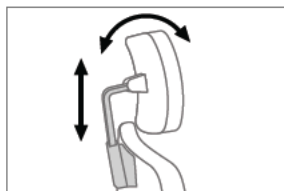

Înălțimea și pivotul tetierei

ȘEZUT

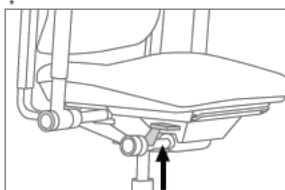

Înălțimea șezutului

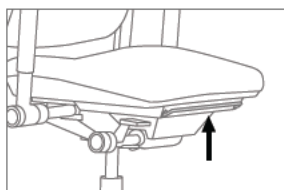

Adâncimea șezutului

MECANISM

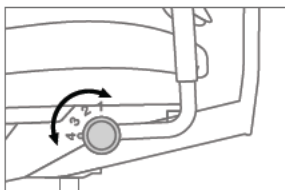

Limitatorul de înclinare

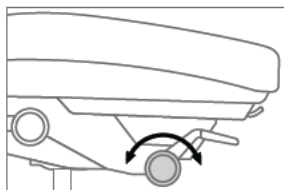

Tensiunea de înclinare

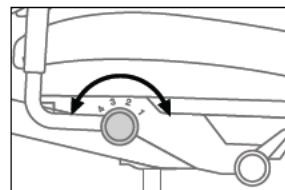

Tensiunea de înclinare lombară

COTIERE

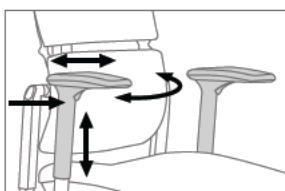

Înălțimea, adâncimea, pivotul și lățimea cotierei

GARANȚIE

Vă rugăm să aveți în vedere că produsul trebuie utilizat doar ca scaun de lucru pentru birou: orice altă utilizare poate fi periculoasă pentru propria dvs. siguranță. Scaunul de lucru standard este testat în conformitate cu EN 1335-1,2 (zi normală de 8 ore de către persoane cu o greutate de până la 110 kg). Pentru înlocuirea ascensorului reglabil cu gaz al scaunului dvs. doar persoane calificate (personal Steelcase și ingineri ai dealerilor) pot efectua service-ul produsului. Țesături/Garanție: pentru orice sfat pentru îngrijirea scaunului dvs. și informații privind garanțiile generale, vă rugăm să verificați site-ul web sau la dealerul Steelcase de unde ați achiziționat scaunul.

Please Réglages

DOSSIER

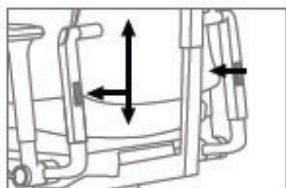

Hauteur du dossier

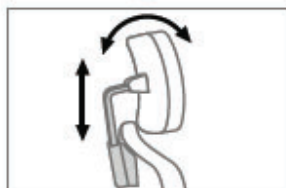

Hauteur et angle de la tête

ASSISE

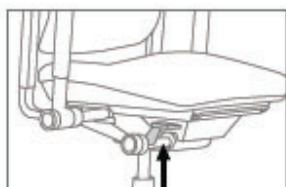

Hauteur d'assise

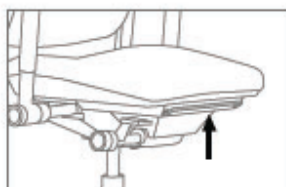

Profondeur d'assise

MECANISME

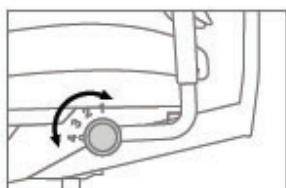

Limiteur de basoulement

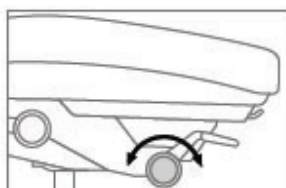

Tension de basoulement

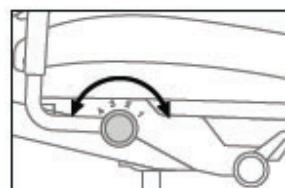

Tension lombaire

ACCOTOIRS

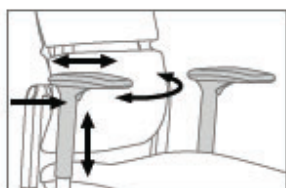

Hauteur, profondeur, largeur et angle des accotoirs

ROULETTES

Pour favoriser le mouvement et la mobilité, un choix de 2 types de roulettes en fonction du sol est disponible : roulettes molles pour sols durs (carrelage, parquet...), roulettes dures pour sols mous (moquette).

GARANTIE

Toute utilisation autre que celle engageant un siège de bureau est formellement déconseillée car pouvant être dangereuse pour la sécurité de son utilisateur. Siège de travail type B selon norme EN 1335-1,2 (soit 8 heures par jour pour un utilisateur dont la corpulence n'excède pas 110 kg). Le vérin de votre siège ne peut être remplacé que par des personnes compétentes (personnel Steelcase, concessionnaires). Revêtement / Garantie : Pour tout conseil concernant l'entretien du revêtement de votre siège ou toute demande d'information concernant la garantie, veuillez vérifier sur le site internet où vous avez effectué votre achat ou veuillez prendre contact avec notre concessionnaire.

Please Einstellungen

RÜCKENLEHNE

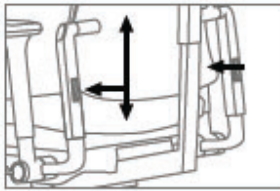

Höhe der Rückenlehne

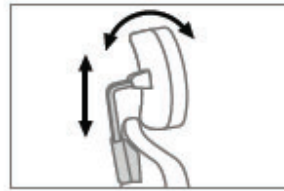

Höhe und Winkel der Kopfstütze

SITZ

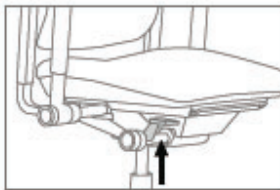

Sitzhöhe

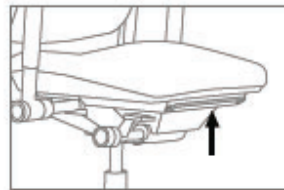

Sitztiefe

MECHANIK

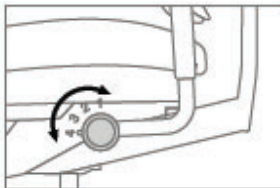

Begrenzung der Rückenlehne

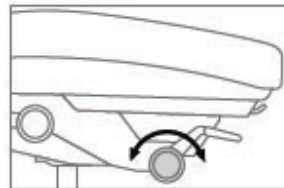

Rückenlehne

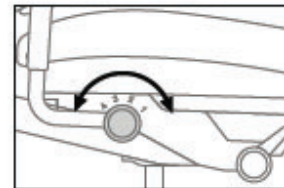

Lumbalbereich

ARMLEHNEN

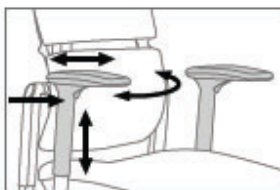

Höhen, Breiten, Tiefen und Winkel verstellbare Armlehnen

LAUFROLLEN

Die Auswahl des Rollentyps Ihres Sitzmöbels hängt von dem Bodenbelag ab: Bei harten Böden (Linoleum, Fliesen, Parkett...) sollten weiche Laufrollen eingesetzt werden. Bei weichen Böden (Teppichboden...) sollten harte Laufrollen eingesetzt werden.

GARANTIE

Bitte beachten Sie, dass die Garantie Ihres Bürodrehstuhles nur bei bestimmungsgemäßen Gebrauch gewährleistet ist. Eine andere Nutzung kann Ihre Sicherheit gefährden. Bürodrehstuhl Typ B gemäß EN 1335-1,2 (bei einem normalen Arbeitstag von 8 Stunden und einer Gewichtsbelastung bis 110 kg). Die Gasfeder Ihres Sitzmöbels sollte nur von geschultem Personal ausgetauscht werden. Pflege/ Garantie – Falls Sie eine Pflegeanleitung für den Bezug Ihres Sitzmöbels benötigen oder Fragen zur allgemeinen Garantie haben, besuchen Sie bitte die Internetseite Ihres Fachhändlers (bei dem Sie den Stuhl bestellt haben).

Please Instellingen

RUGLEUNING

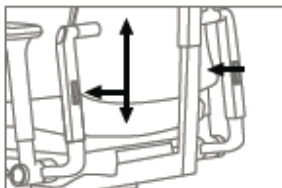

Hoogte van de rugleuning

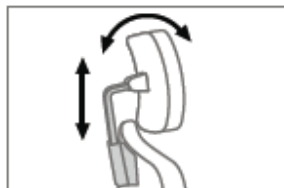

Hoogte en hoek van de hoofdsteun

ZITTING

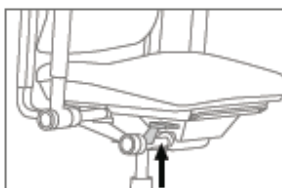

Zithoogte

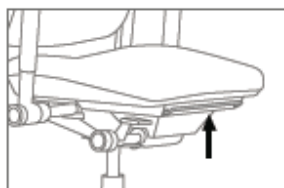

Zitdiepte

MECHANISME

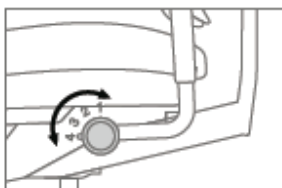

Neelhoekbegrenzer van de rugleuning

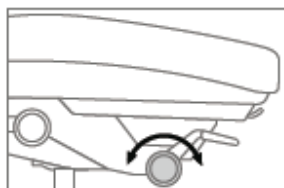

Neiging van de rugleuning

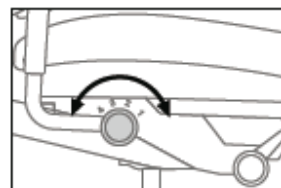

Lendensteun

ARMSTEUNEN

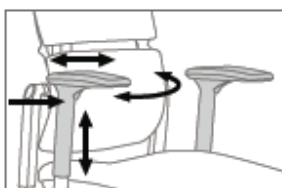

Hoogte, breedte, hoek en diepte van de armleuningen

WIELTJES

Bij de keuze van de wieltjes van uw stoel moet u rekening houden met de vloerbedekking. Op harde vloeren (linoleum, tegels, parket) gebruikt u zachte wieltjes. Op zachte vloeren (tapijt) gebruikt u harde wieltjes.

ONDERHOUD

Attentie: Dit product mag alleen als bureaustoel gebruikt worden: alle andere toepassingen kunnen gevaarlijk zijn voor uw veiligheid. De standaard bureaustoel is getest volgens EN 1335-1,2 (normaal gesproken 8 uur per dag door personen met een gewicht tot 110 kg). Op zachte vloeren (tapijt) gebruikt u harde wieltjes. Alleen deskundig personeel (Steelcase personeel en dealer ingenieurs) kan de gasveer van uw stoel vervangen op de werkplek. Stoffen / garantie – Voor elk advies inzake het onderhoud van de bekleding van uw stoel en voor meer informatie over algemene garanties, kijk op de website van uw dealer (waar u uw stoel heeft gekocht).

Please Regolazioni

SCHIENALE

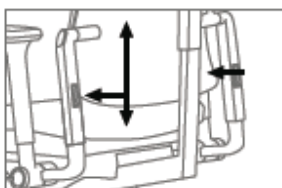

Altezza schienale

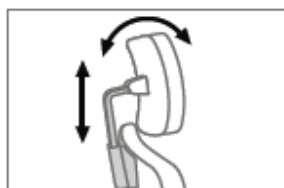

Altezza e angolo dell'appoggiatesta

SEDILE

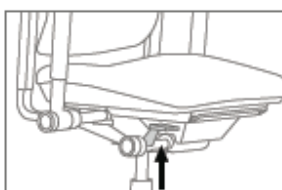

Altezza del sedile

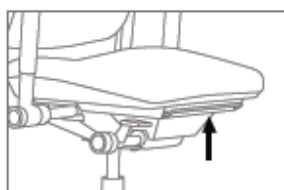

Profondità del sedile

MECCANISMO

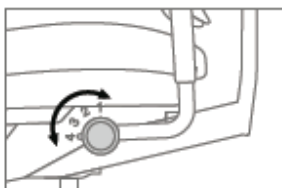

Limitatore di basculamento

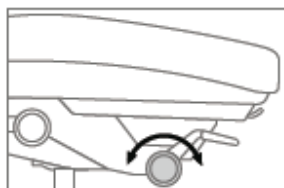

Tensione di oscillazione

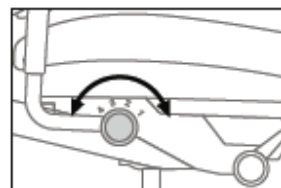

Tension lombare

BRACCIOLI

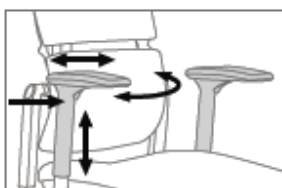

Altezza, apertura, rotazione e profondità dei braccioli

RUOTE

La scelta delle ruote dipende dal tipo di pavimento su cui la sedia sarà utilizzata: per pavimenti duri (es. pietra, legno, laminato, linoleum, ecc.) scegliere ruote morbide. Su pavimenti morbidi (es. moquette, ecc.) optare per ruote dure.

GARANZIA

Si ricorda che il prodotto è previsto esclusivamente per utilizzo come sedia da ufficio: qualsiasi altro utilizzo è pericoloso per la vostra sicurezza. La sedia ufficio operativa standard è testata a norma EN 1335-1,2 (8 ore al giorno per persone con peso fino a 110 Kg). Per la sostituzione della colonna pneumatica di regolazione dell'altezza della seduta, è esclusivamente necessario l'intervento in loco di personale qualificato (dipendenti Steelcase e tecnici specializzati dei rivenditori). Rivestimento / Garanzia: per tutte le informazioni relative alla manutenzione del rivestimento della vostra sedia, e per informazioni sulla garanzia generale, consultare le istruzioni per l'uso sul sito web o contattare il nostro rappresentante e/o rivenditore.

Regulaciones Please

RESPALDO

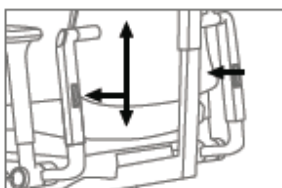

Altura del respaldo

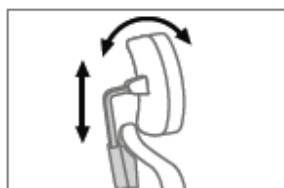

Altura y ángulo del reposa-cabeza

ASIENTO

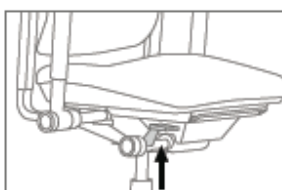

Altura del asiento

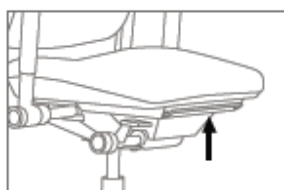

Profundidad del asiento

MECANISMO

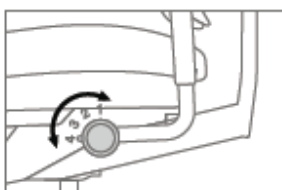

Limitador de basculación

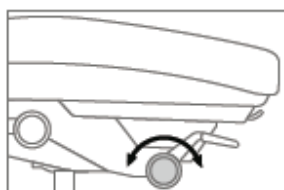

Tensión de basculación

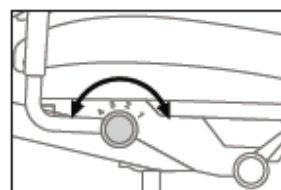

Tensión lumbar

BRAZOS

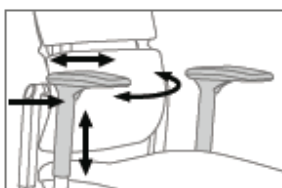

Altura, profundidad, ángulo y anchura de los brazos

RUEDAS

Para facilitar la movilidad del usuario, se puede elegir entre 2 opciones de ruedas en función del suelo disponible: ruedas blandas para suelos duros (enlosado, parquet...), ruedas duras para suelos blandos (moqueta).

GARANTÍA

Rogamos tengan en cuenta que este producto se debe usar como silla de trabajo: cualquier otro uso inadecuado podría generar riesgos para su seguridad. Silla de trabajo diseñada para cumplir los requisitos de la norma europea vigente EN 1335-1,2 (jornada de trabajo de 8 horas para personas con un peso máximo de 110kg). El nivelador de su silla sólo podrá ser sustituido por personas especializadas.
Revestimientos / Garantía: Para cualquier consejo básico sobre el mantenimiento del revestimiento de su silla, así como para obtener información sobre las condiciones generales de garantía, por favor, consulte las instrucciones de uso en la página web o contacte con nuestro comercial y/o concesionario.

Comandos Please

COSTA

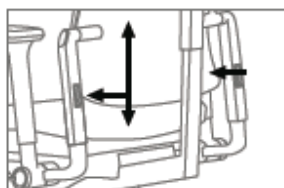

Altura da costa

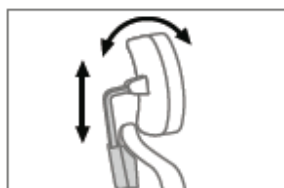

Altura e angulo cabeça

ASSENTO

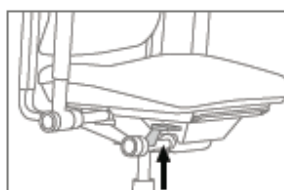

Altura do assento

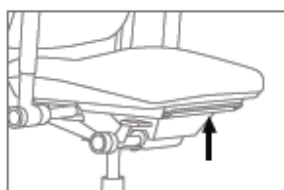

Profundidade do assento

MECANISMO

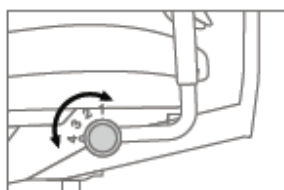

Limitador de basoulação

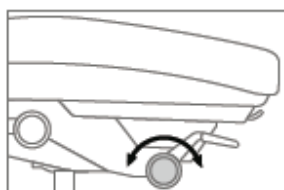

Tensão de basoulação

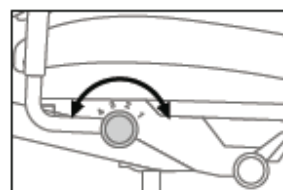

Tensão lombar

BRAÇOS

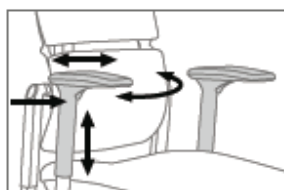

Altura, largura, rotação e profundidade dos braços

RODÍZIOS

Para favorecer o movimento e a mobilidade, é possível escolher entre 2 tipos de rodízios em função do solo: Rodízios macios para solos duros (ladrilhos, parquet...). Rodízios duros para solos macios (alcatifa).

GARANTIA

Observe que o produto só deve ser utilizado como cadeira de trabalho de escritório: qualquer outro tipo de utilização pode ser perigoso para a sua segurança. A cadeira de trabalho padrão é testada em conformidade com a norma EN 1335-1,2 (dia de trabalho normal de 8 horas por pessoas com peso até 110 kg). O lift da sua cadeira só deverá ser substituído por pessoal qualificado (técnicos Steelcase). Revestimento / Garantia: para qualquer esclarecimento sobre a manutenção do revestimento da sua cadeira, consulte as instruções de utilização no página web ou contacte o nosso representante de vendas e/ou revendedor.

Регулировки Please

СПИНКА

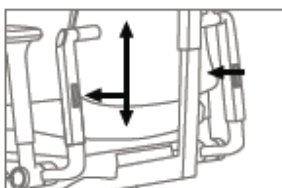

Регулировка спинки по высоте

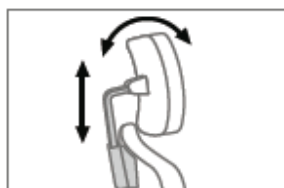

Высота и вращение подголовника

СИДЕНЬЕ

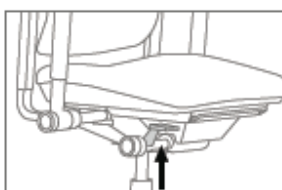

Регулировка высоты сиденья

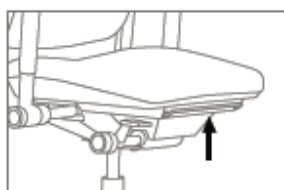

Регулировка глубины сиденья

МЕХАНИЗМ

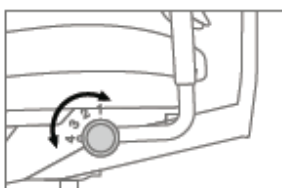

Ограничитель откидывания спинки

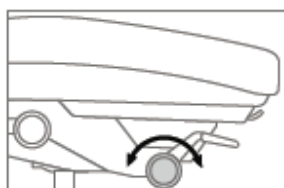

Регулировка силы откидывания спинки

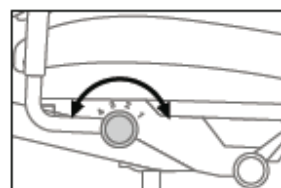

Сила натяжения нижнего (поясничного) отдела спинки

ПОДЛОКОТНИКИ

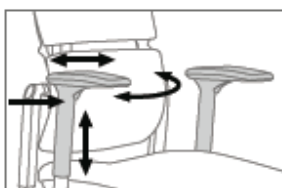

Высота, ширина, вращение, глубина регулируемых подлокотников

КОЛЕСИКИ

Выбор колесиков зависит от вида напольного покрытия, на котором будет использоваться кресло, - для жесткого пола (камень, дерево, ламинат и т.д.) выбирайте мягкие колесики. Для мягкого покрытия (ковролин и т.д.) выбирайте жесткие колесики.

ГАРАНТИЯ

Обратите внимание: данное изделие предназначено только для использования в офисном режиме работы. Любое другое применение может быть небезопасным. Кресло соответствует стандарту EN 1335-1,2 (8 часовой рабочий день для человека весом не более 110 кг). Выбирайте жесткие колесики. Газлифт: для замены регулируемого газлифта кресла обращайтесь только к специалистам (сотрудникам Steelcase или инженерам дилера), которые на месте произведут все работы. Обивка / гарантия: по всем вопросам об уходе за креслом и предоставляемых гарантиях Пожалуйста, проверьте на сайте, на котором Вы купили стул свяжитесь или же вашим дилером.

ضوابط Please

مسند الظهر

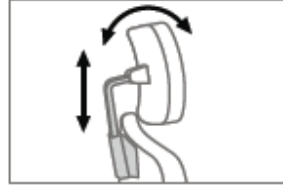

ارتفاع مسند الرأس والمحور

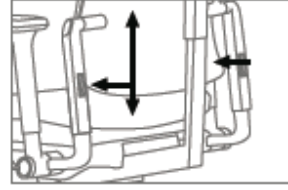

ارتفاع الظهر

المقعد

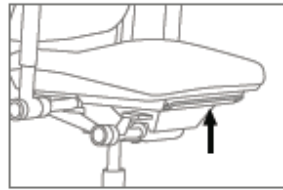

عمق المقعد

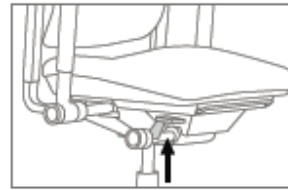

ارتفاع المقعد

التقنية

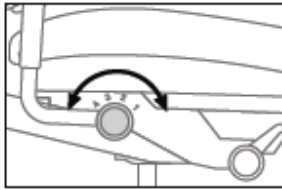

ضغط إمالة أسفل الظهر

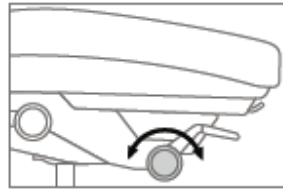

ضغط الإمالة

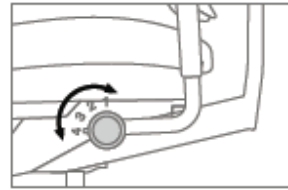

مسند ظهر متحرك \ محدد الإمالة

مسند الذراع

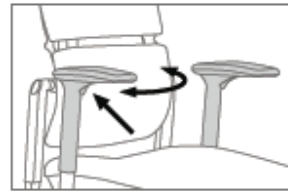

ارتفاع مسند الذراع والجوف والمحور

العجلات

يتم اختيار نوع العجلات تبعاً للأرضية التي سيستخدم عليها الكرسي - للإرضيات الصلبة (بلاط، خشب، باركيه، لينوليوم، الخ) يجب اختيار العجلات الناعمة. أما للإرضيات الناعمة (السجاد، الخ) فيجب اختيار العجلات الصلبة.

الضمان

يرجى الانتباه إلى أنه يجب استخدام المنتج ككرسي عمل مكتبي فقط. أي استخدام آخر يمكن أن يكون خطيراً على سلامتك. تم اختبار الكرسي عن طريق EN 1335-1,2 (خلال يوم عمل عادي مكون من 8 ساعات من قبل أشخاص يصل وزنهم إلى 110 كجم). لإستبدال الرافعة في كرسيك، الرجاء التواصل مع الأشخاص المؤهلين فقط (موظفي ستيلكيس ومهندسي الموزع المعتمد) الذي بإمكانهم التعامل مع المنتج. الأقمشة / الضمان: للحصول على أي نصيحة أساسية حول العناية بكرسيك والمعلومات المتعلقة بالضمانات، يرجى التحقق من الموقع الإلكتروني أو موزع ستيلكيس المعتمد الذي اشتريت منه كرسيك.