

---

## Studio50 Panels

Assembly Instructions

# Fixing Studio50 Panel to Wall

## Assembly Instructions

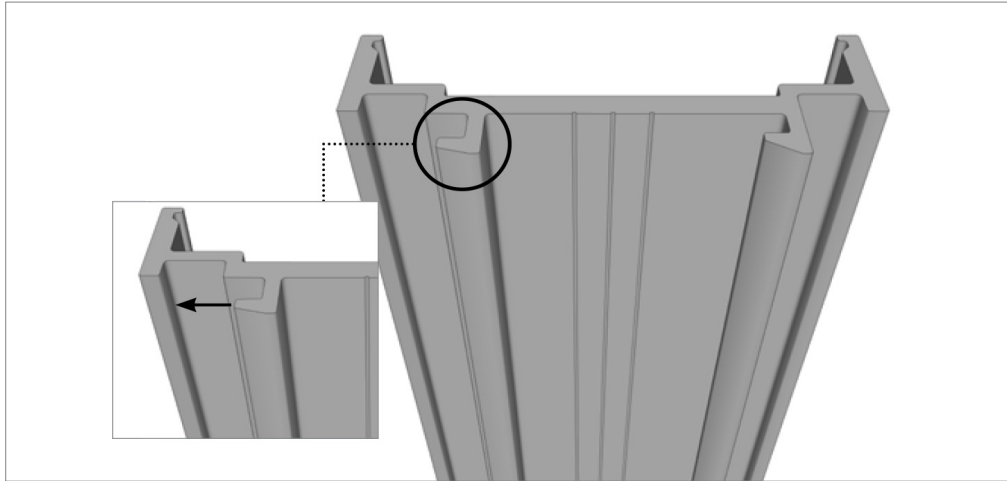

**STEP 1:** Fix wall start extrusion (STU50SID.../...) vertically to wall. Pack Wall Start Extrusion to desired distance from wall. Locking tabs should point left when facing you.

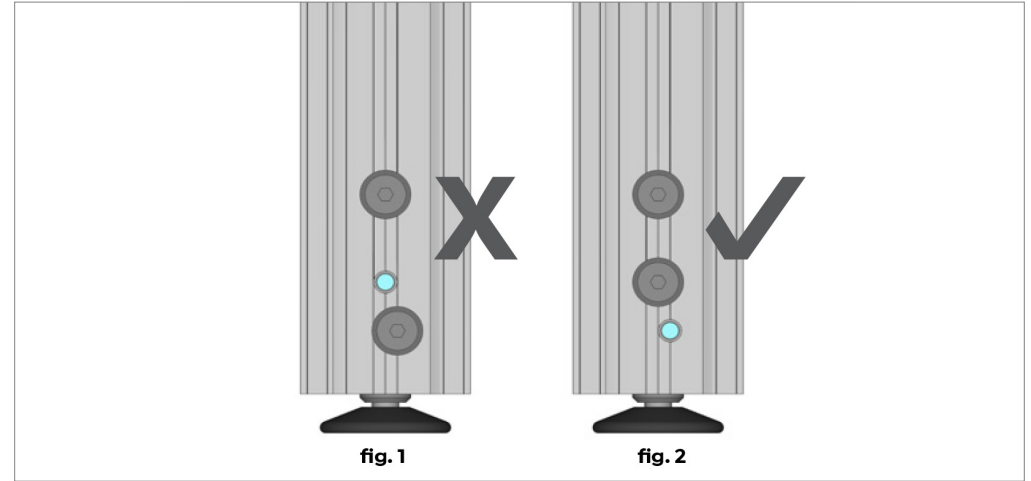

**STEP 2:** Each end of a Studio50 panel has 3 fixing holes at the bottom, but only 2 fixing screws. The fixing screws at each end are in different positions. Use the end shown in **fig. 2** to attach to Wall Start.

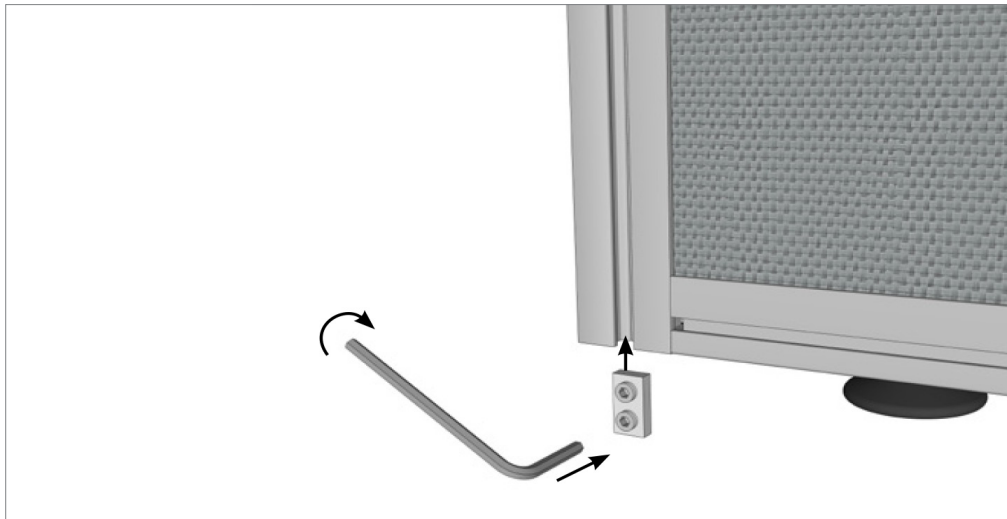

**STEP 3:** Align panel slightly to the left of the wall start, move panel to your right to lock in position and level the panel. Lock at bottom with T-slot nut (STU50TSN) using 3mm allen key.

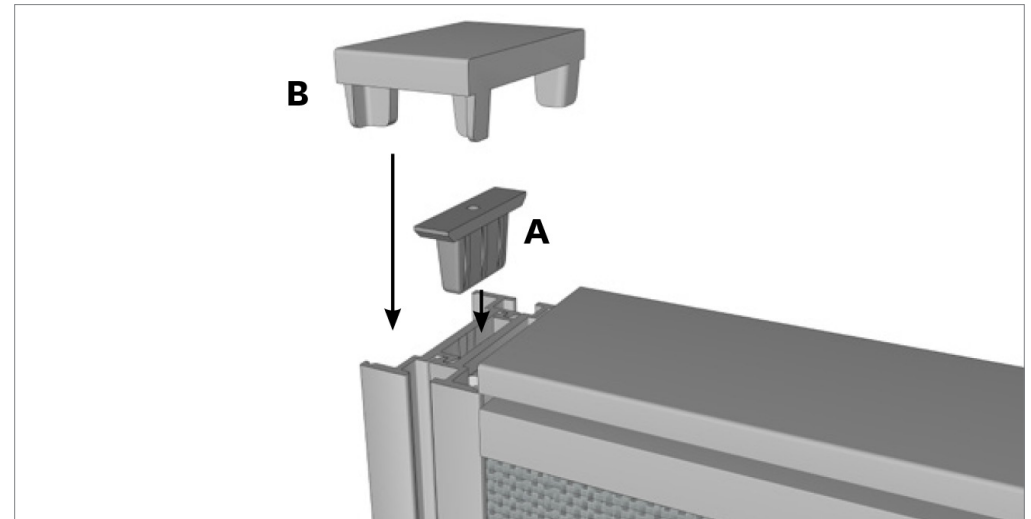

**STEP 4:** Fit join lock **(A)** (STU50SLCK) then end cap **(B)** (STU50RCP/...) to top of panel.

# Fixing Studio50 Panel to Post

Assembly Instructions

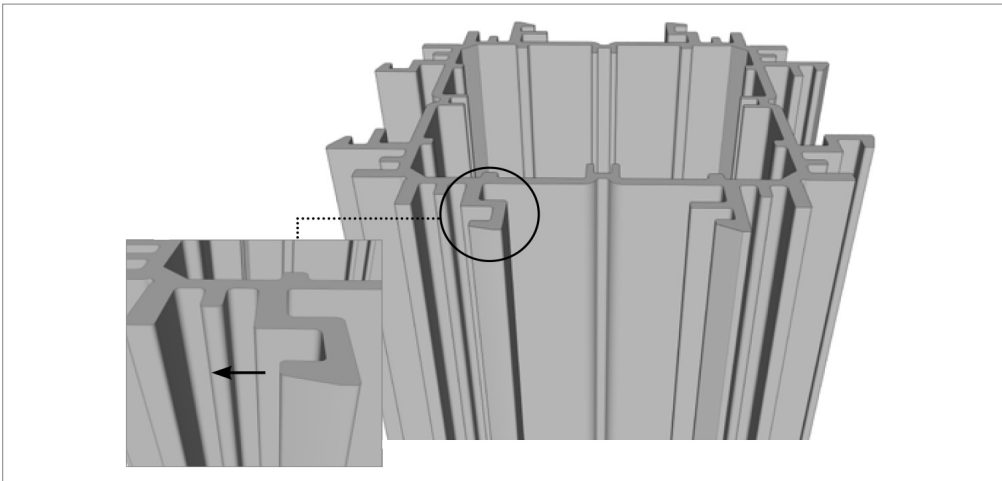

**STEP 1:** Locking tabs should point left when facing you.

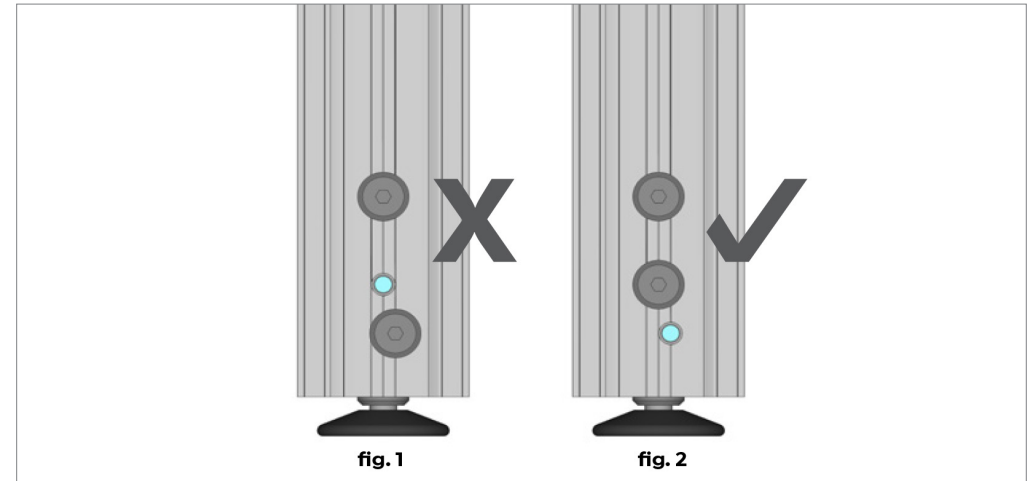

**STEP 2:** Each end of a Studio50 panel has 3 fixing holes at the bottom, but only 2 fixing screws. The fixing screws at each end are in different positions. Use the end shown in **fig. 2** to attach to Post.

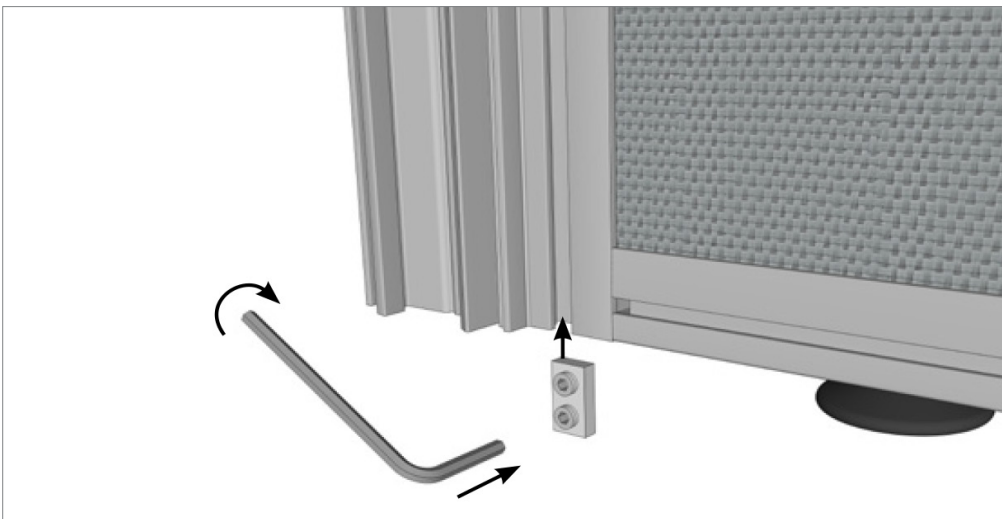

**STEP 3:** Align panel slightly to the left of the post, move panel to your right to lock in position and level the panel. Lock at bottom with T-slot nut (STU50TSN) using 3mm allen key.

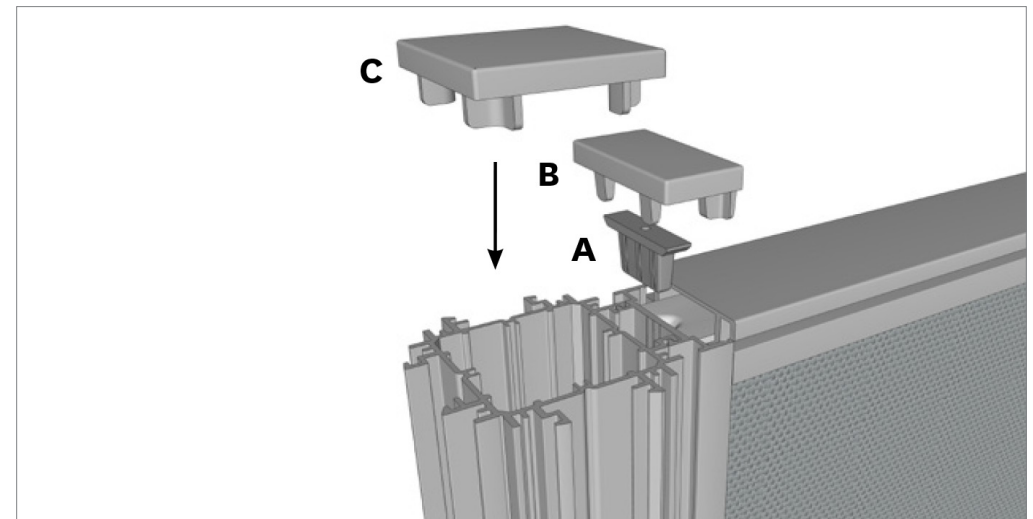

**STEP 4:** Fit joint lock (A) (STU50SLCK) then end cap (B) (STU50ECP/...) to top of panel and post cap (C) (STU50PSTCP90/... or STU50PSTCP120/...)

# Fixing Studio50 Panel End

## Assembly Instructions

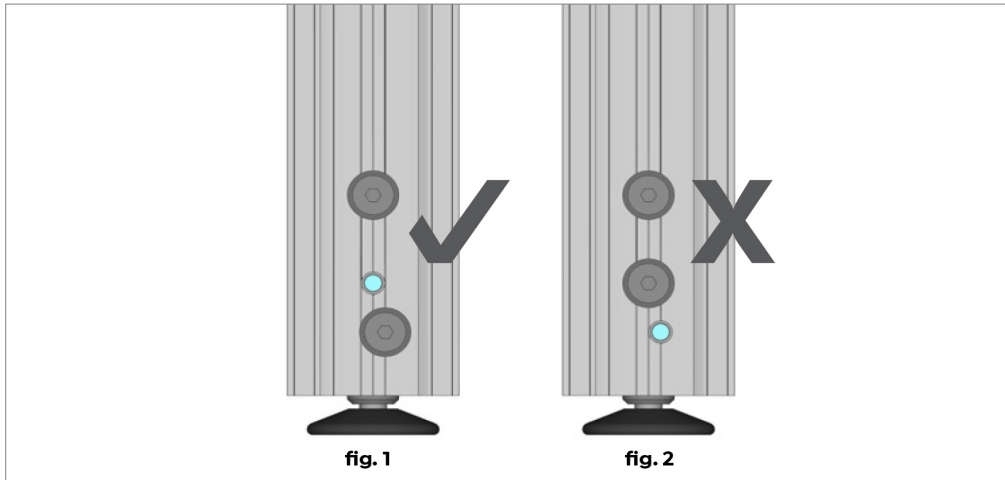

**STEP 1:** Each end of a Studio50 Panel has 3 fixing holes at the bottom but only 2 fixing screws. Ensure that these 2 screws are located in the upper and lower fixing holes. See **fig 1**.

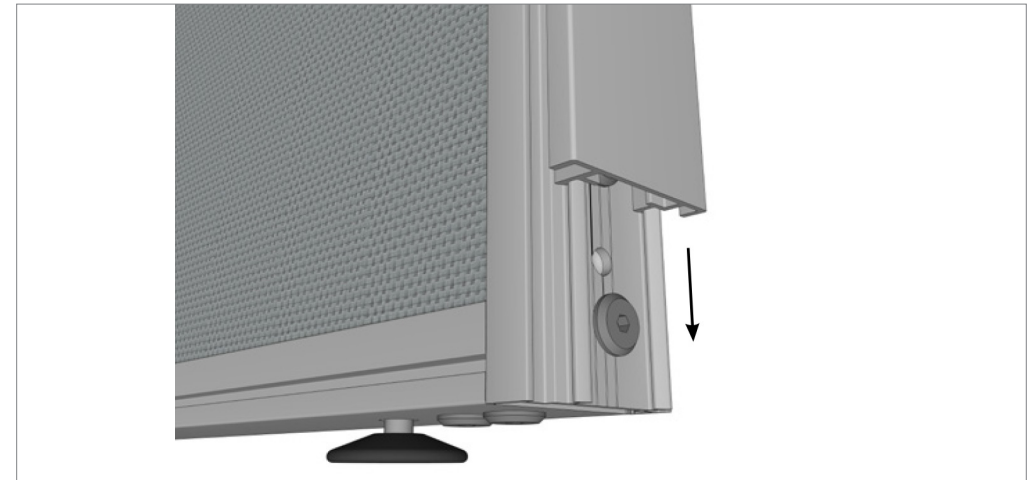

**STEP 2:** Raise the top of panel finish extrusion 50mm above top of panel, move Panel Finish from left to right to engage in position. Slide down to level in position and auto lock.

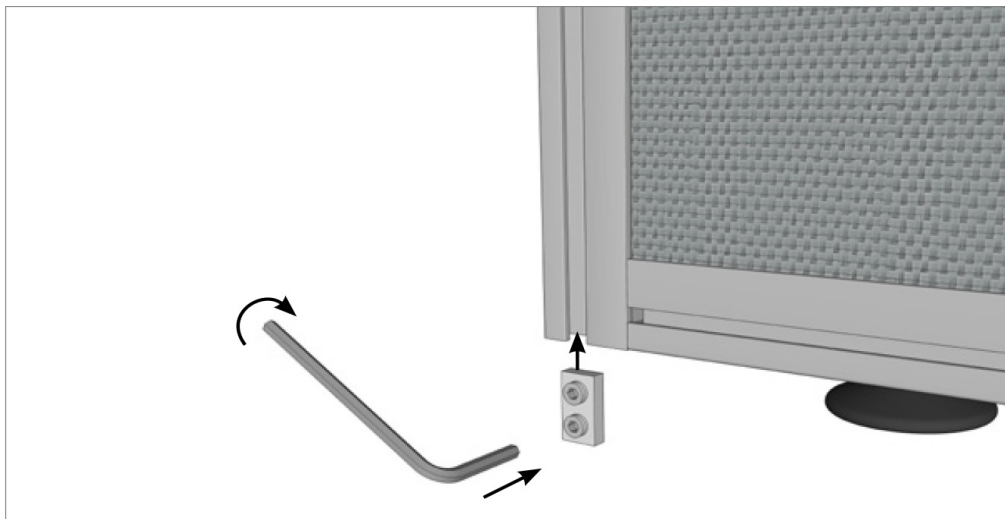

**STEP 3:** Lock at bottom with T-slot nut, using 3mm allen key.

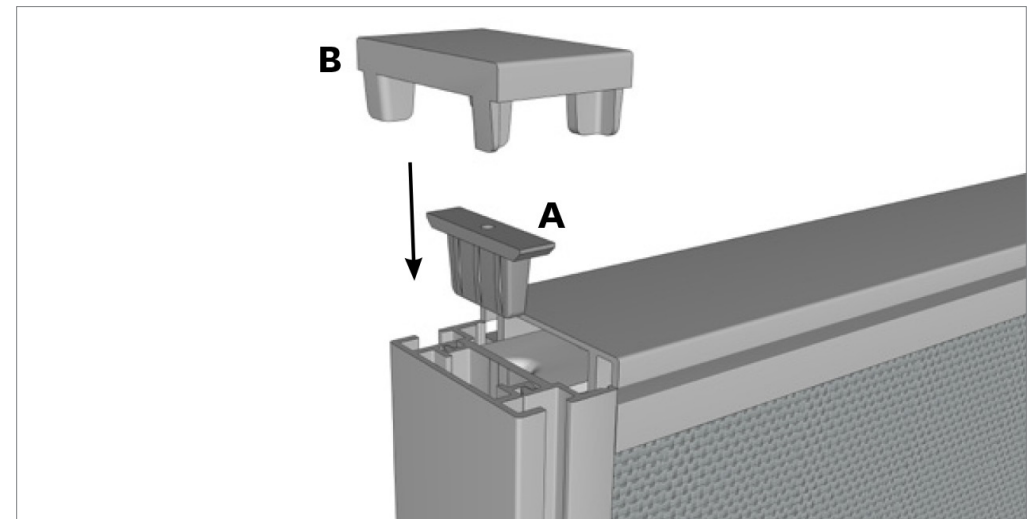

**STEP 4:** Fit join lock (A) (STU50SLCK) then end cap (B) (STU50ECP/...) to top of panel.

# Joining Two Studio50 Panels

Assembly Instructions

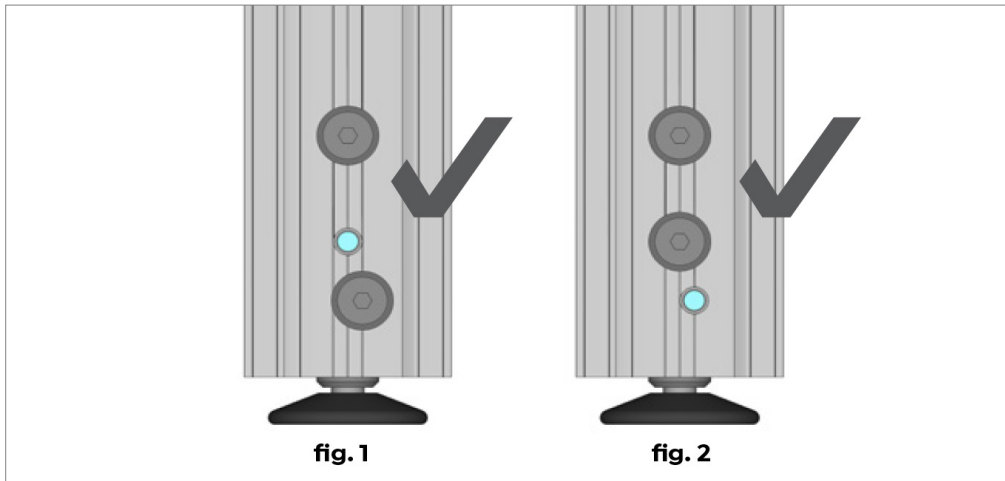

**STEP 1:** Each end of a Studio50 Panel has 3 fixing holes at the bottom but only 2 fixing screws. Ensure that of the two panel ends to be joined, one has the 2 screws located in the top and bottom fixing holes See fig 1, and the other the 2 screws located in the top and middle fixing holes See fig 2. If not, move one screw on one panel end to the lower off-centre position.

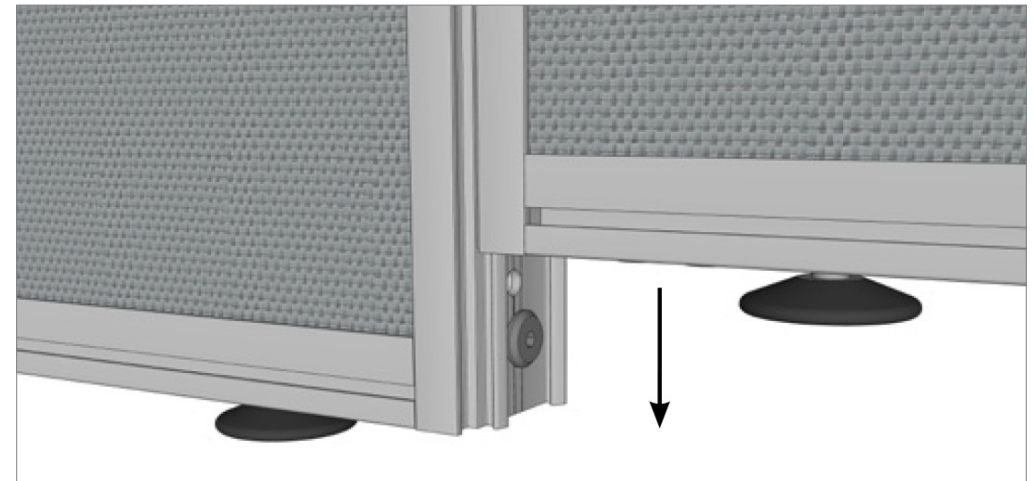

**STEP 2:** Raise the panel with fixing screws located in top and middle fixing holes about 50mm above the other panel. Move panel from left to right to engage in position. Slide down to level in position and auto lock.

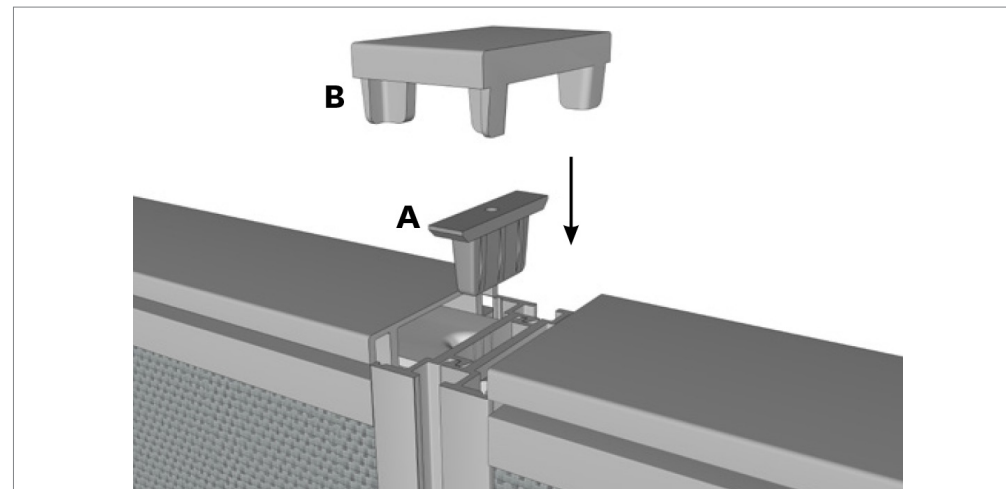

**STEP 3:** Level panel then fit joint lock (A) (STU50SLCK) then run cap (B) (STU50RCP/...) to top of panel.

# Joining Wing Screen Panels

## Assembly Instructions

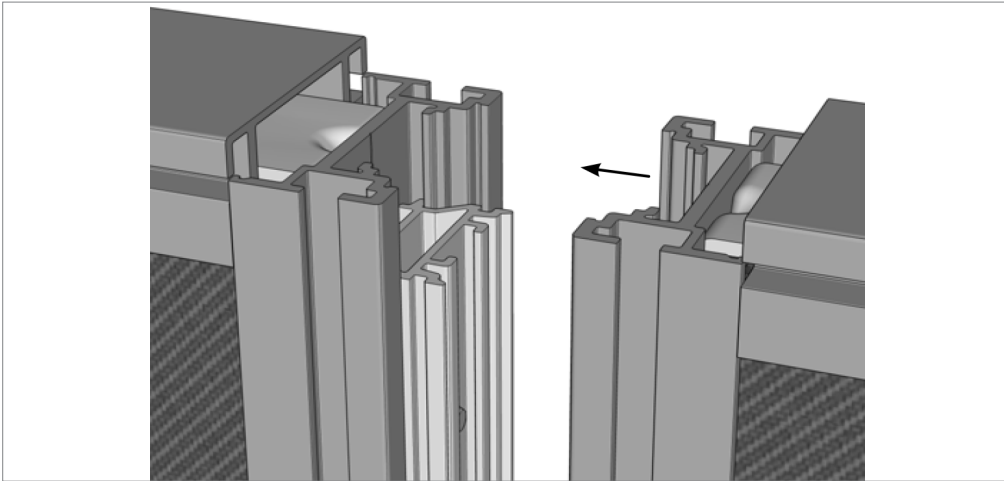

**STEP 1:** Align panel slightly to the left of the post, move panel to your right to lock in position and level the panel. Lock at bottom with T-slot nut (STU50TSN) using 3mm allen key.

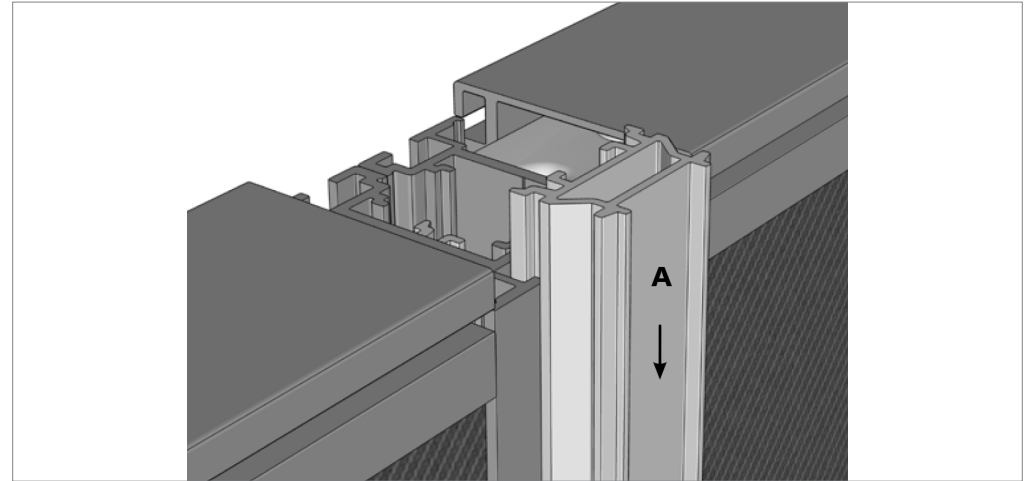

**STEP 2:** Fit join lock (A) (STU50SLCK) then end cap (B) (STU50ECP/...) to top of panel.

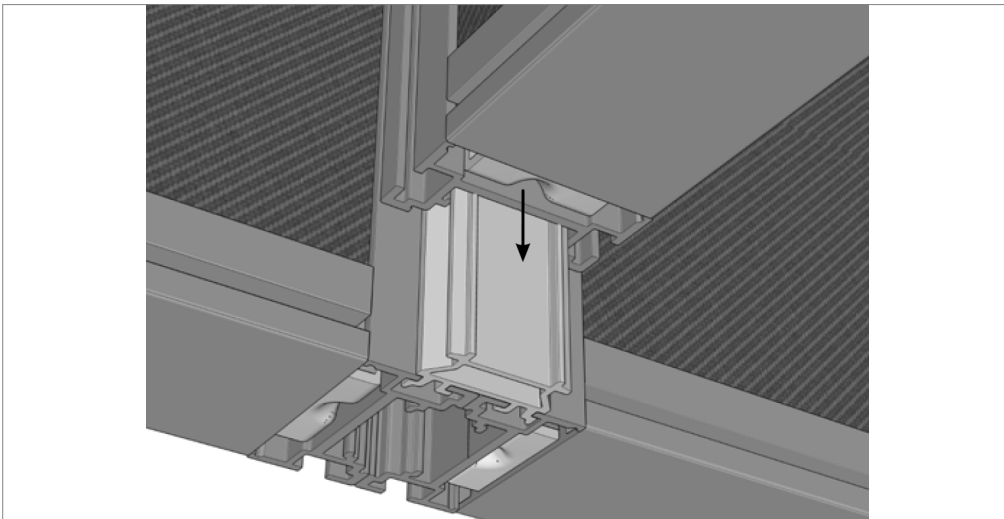

**STEP 3:** Add powerpole joiner (A), and screw into place with small screw. Slide top half of powerpole over joiner. Optional, use Qbilical.

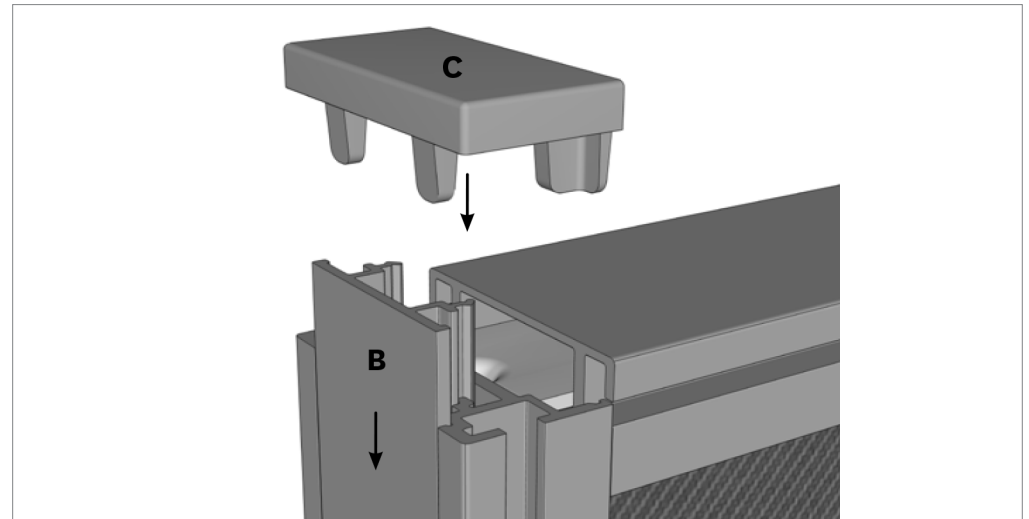

**STEP 4:** Run cables down through powerpole and into ducting.

# Cable Management Ducting

## Assembly Instructions

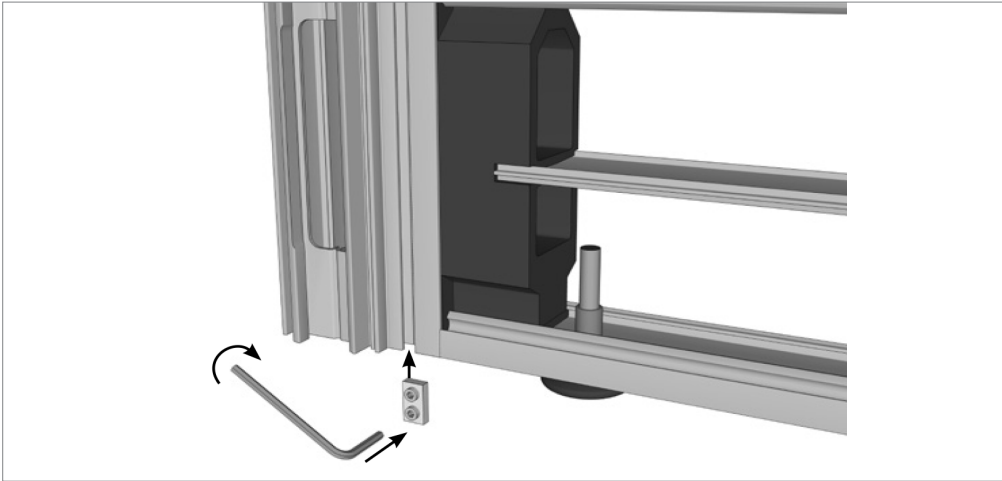

**STEP 1:** Align panel slightly to the left of the post, move panel to your right to lock in position and level the panel. Lock at bottom with T-slot nut (STU50TSN) using 3mm allen key.

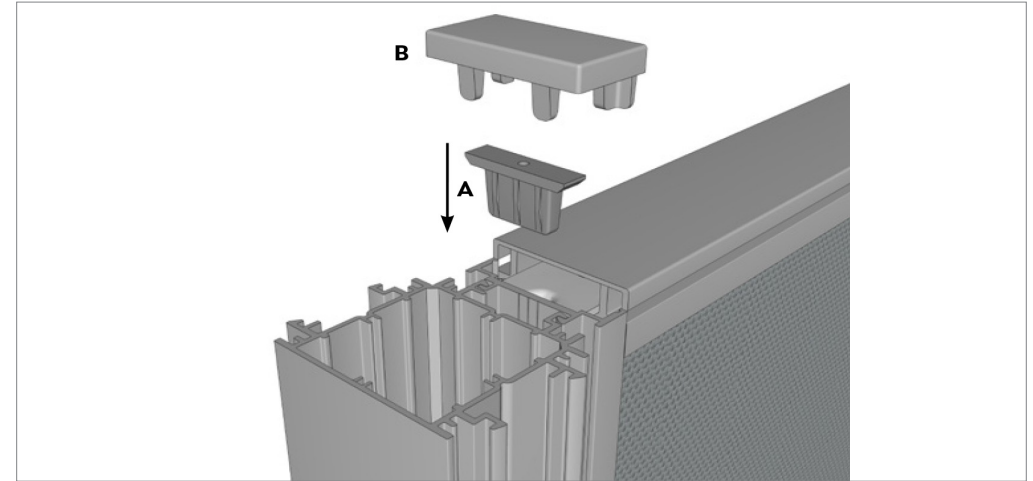

**STEP 2:** Fit join lock (A) (STU50SLCK) then end cap (B) (STU50ECP/...) to top of panel.

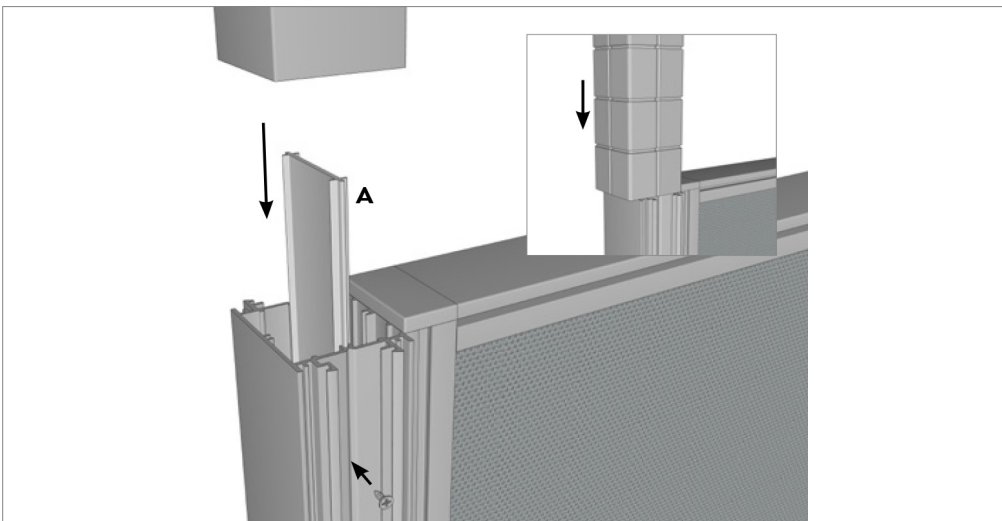

**STEP 3:** Add powerpole joiner (A), and screw into place with small screw. Slide top half of powerpole over joiner. Optional, use Qbilical.

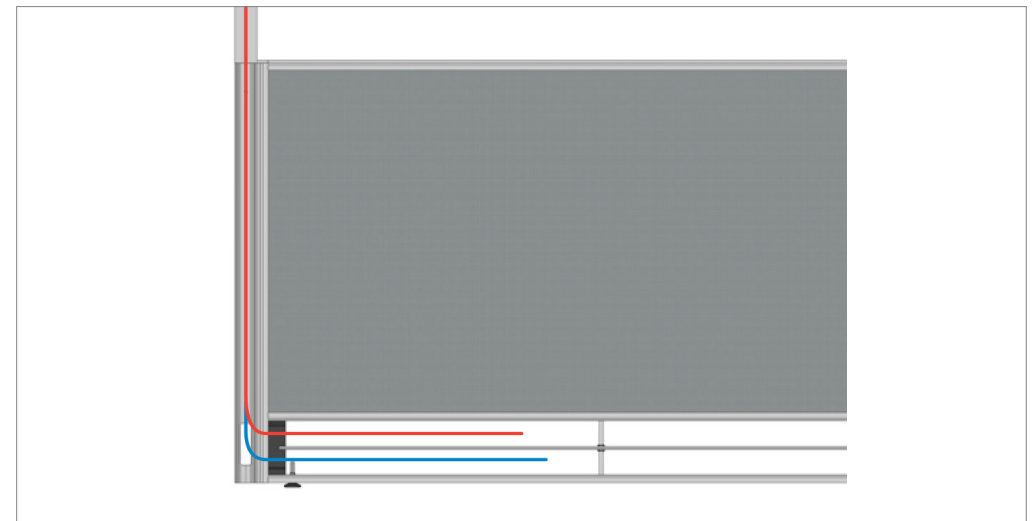

**STEP 4:** Run cables down through powerpole and into ducting.

# Cable Management Ducting

## Assembly Instructions

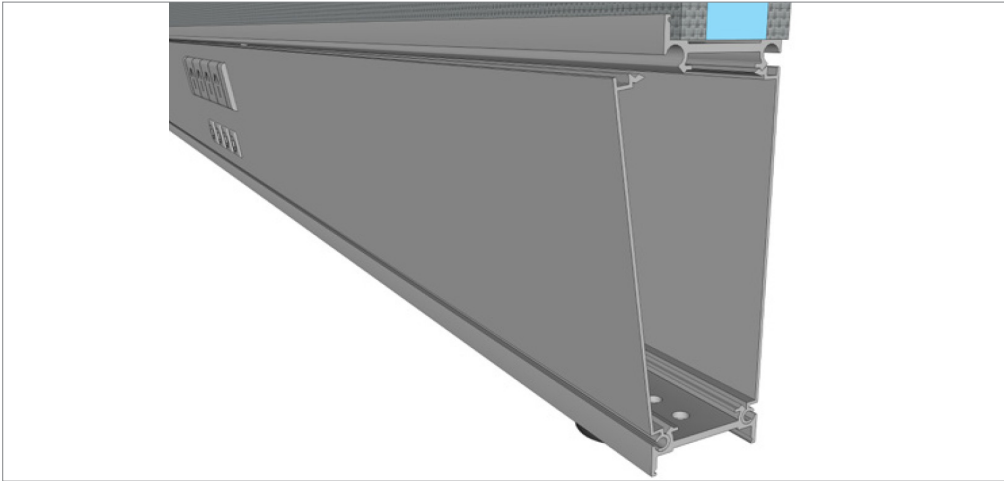

**STEP 5:** Clip the ducting cover and plastics in to the bottom of Studio50 panel.

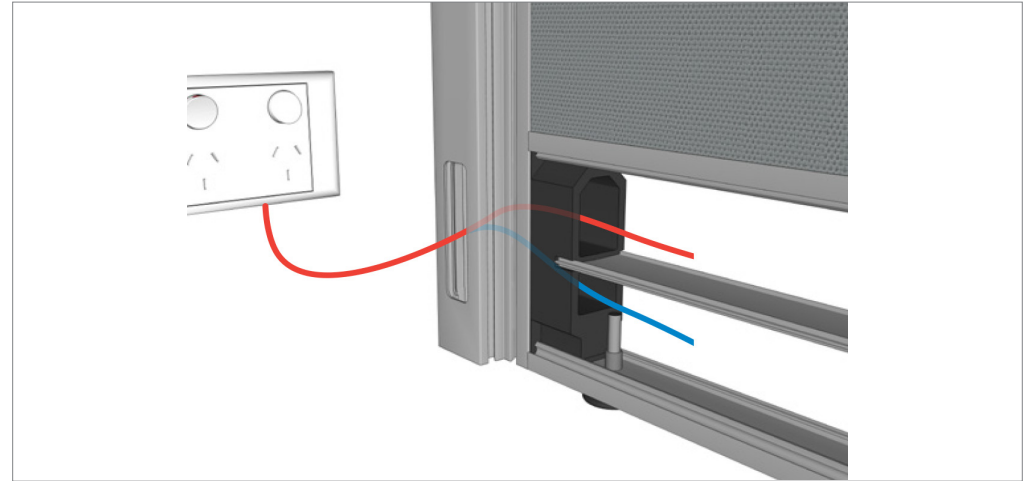

**STEP 6:** Option for wall power outlet.

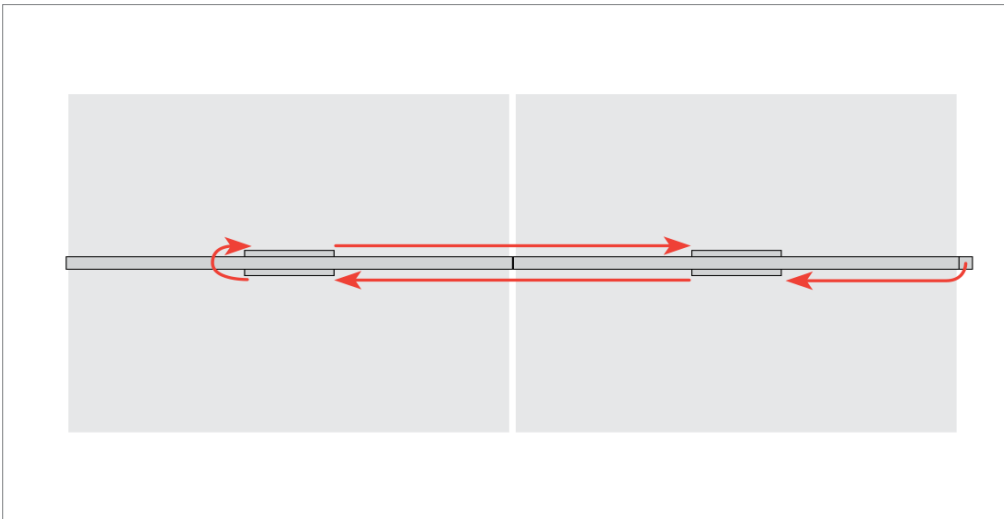

**STEP 7:** Typical wiring setup for double sided desking.

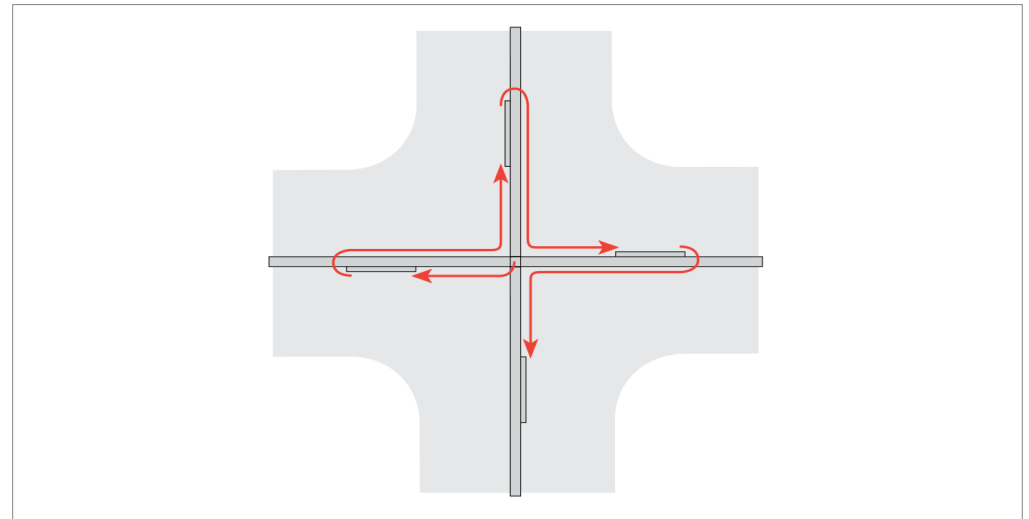

**STEP 8:** Typical wiring setup for workstation pods.



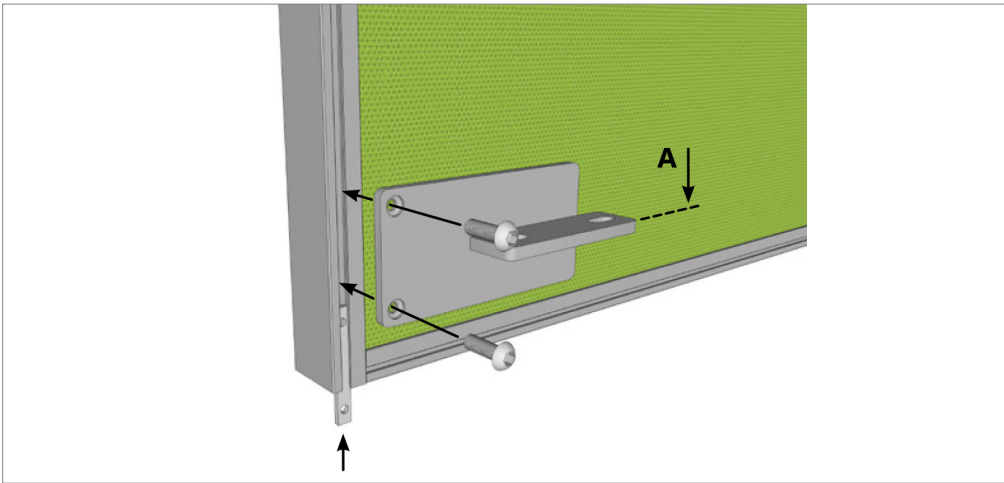

**STEP 1:** Attach one bracket to each end of screen using screws provided with bracket.  
Tip: Fix bracket point 'A' 75mm lower than desired screen projection above worktop.

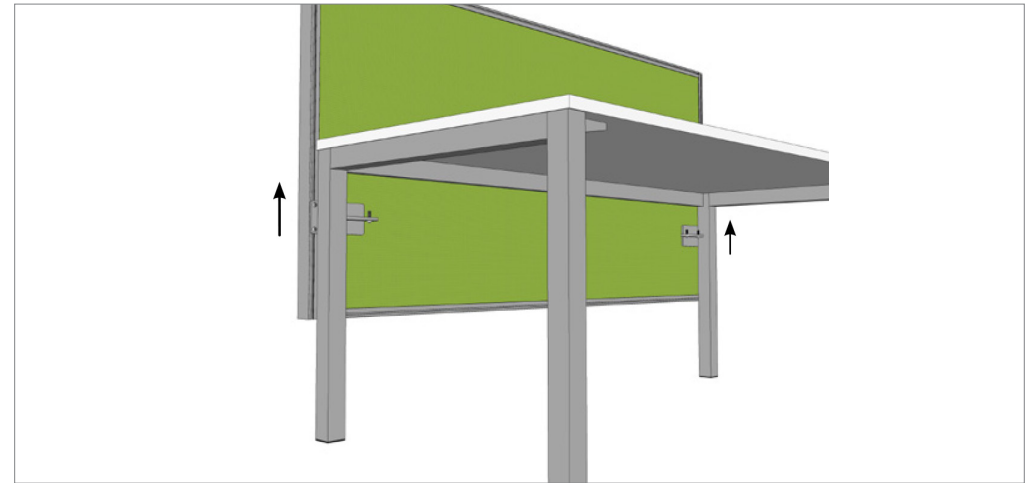

**STEP 2:** Attach Studio50 panel to desk frame.

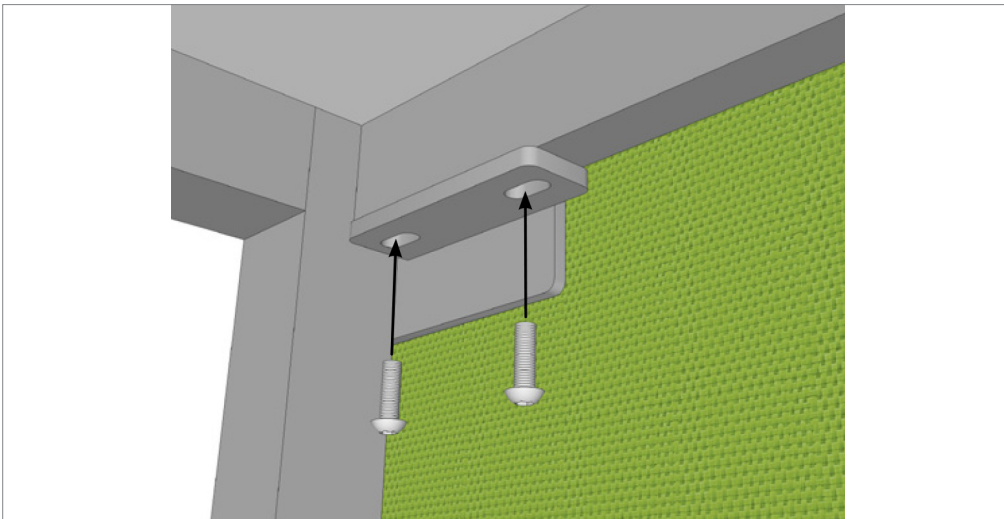

**STEP 3:** Fully tighten desk screws.

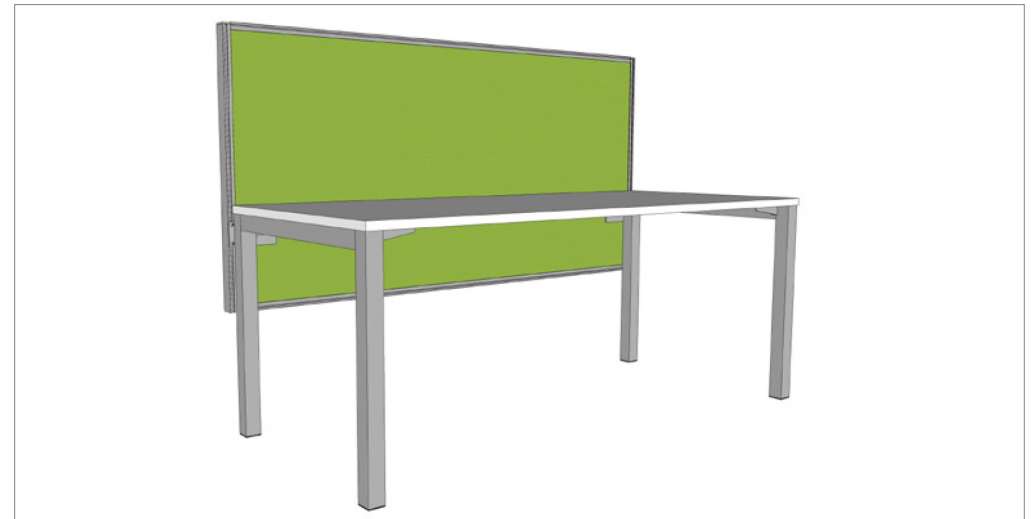

# Fixing Desk Clamp Brackets STU50CBSB

## Assembly Instructions

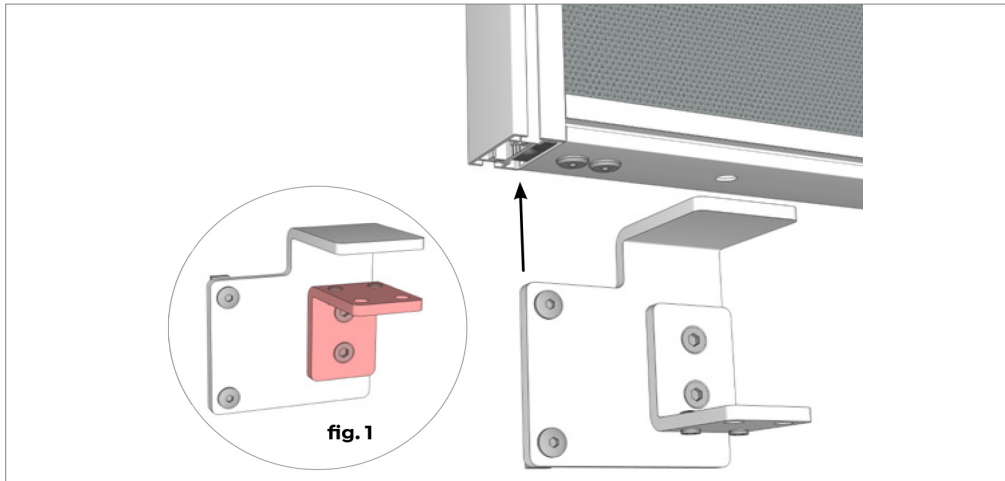

**STEP 1:** Slide each bracket up the panel ends.  
Note: Clamp can accommodate 25mm and 75mm thicknesses by rotating highlighted section of clamp in **Fig 1**.

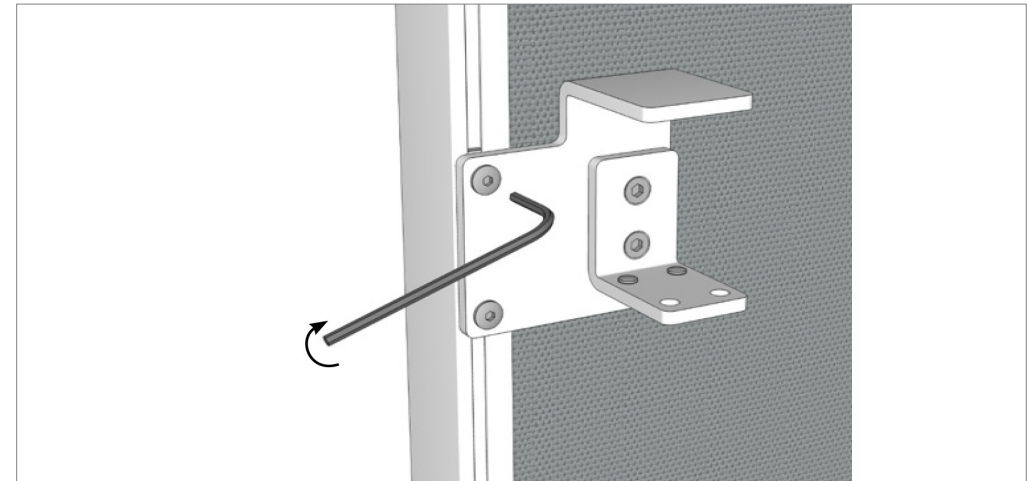

**STEP 2:** Locate the top of each bracket 500mm from the top of the Studio50 screen.  
Fully tighten screws to lock bracket in place.

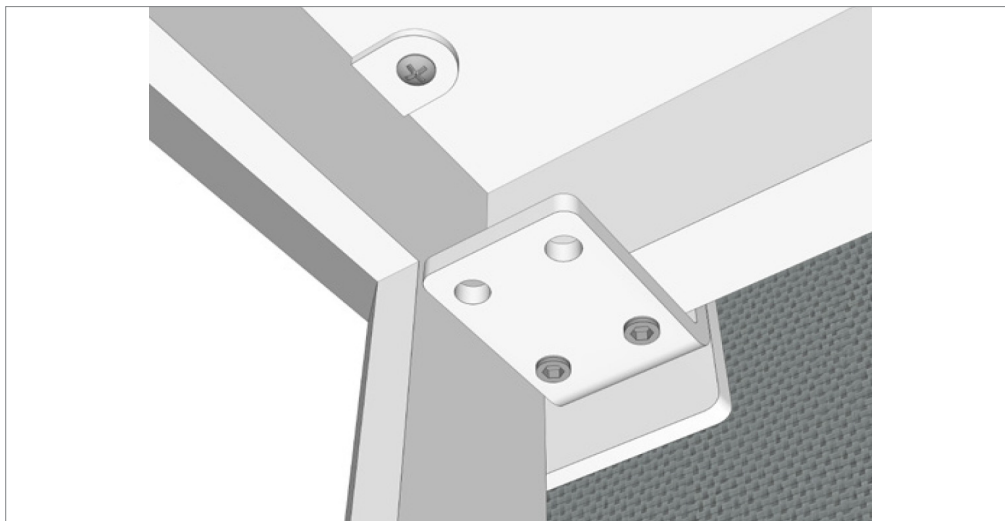

**STEP 3:** Slide the screen onto the back of worksurface, and fully tighten small grub screws on each bracket.

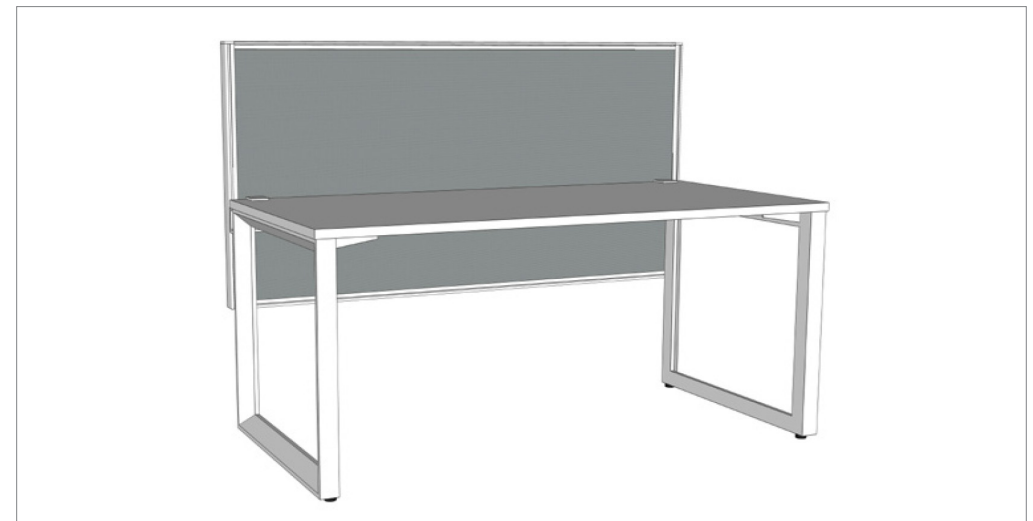

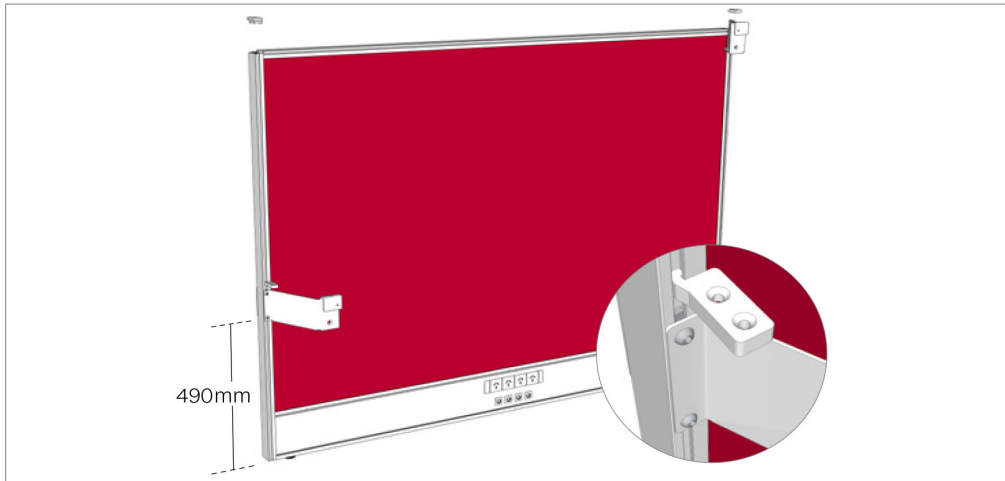

**STEP 1:** Remove Studio50 End Caps, firstly slide brackets down screen, then slide Screen Stabiliser brackets down screen. Lightly tighten brackets 490mm from floor.

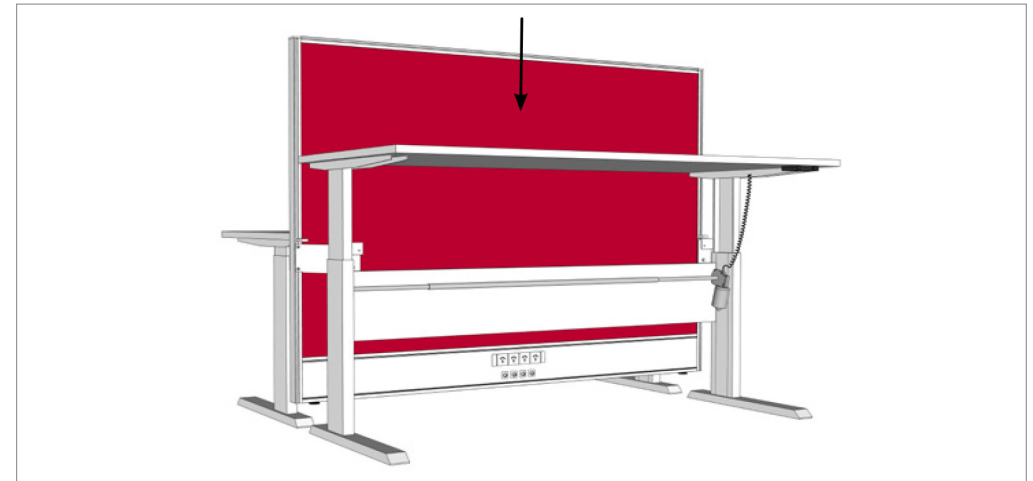

**STEP 2:** Lift and slide screen so the brackets clamp over the desk modesty.

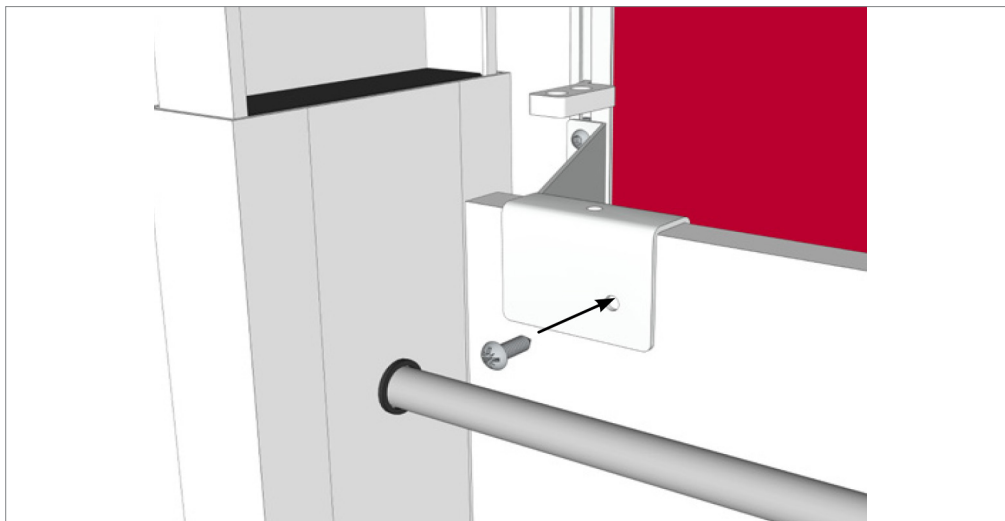

**STEP 3:** Slide the Screen Stabiliser Bracket up. Fully tighten in place with provided self tapping wood screws.

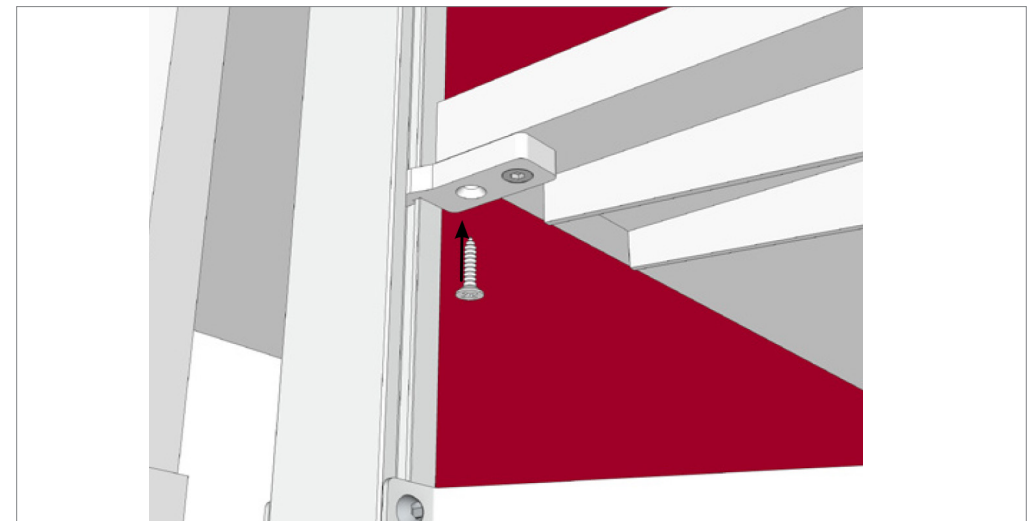

**STEP 4:** Screw self-tapping screws through brackets into modesty panel on both sides of the Studio50 screen. Fully tighten screws on brackets into Studio50 screens.

# Fixing Desk Mounted Brackets STUSWB60

## Assembly Instructions

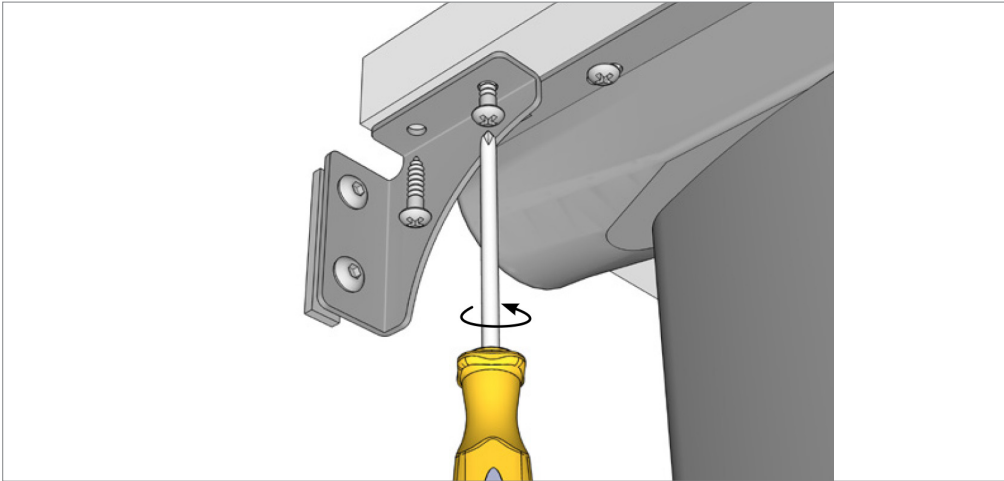

**STEP 1:** Place brackets in the position shown below. Tighten the screws so that the bracket can still move a little.

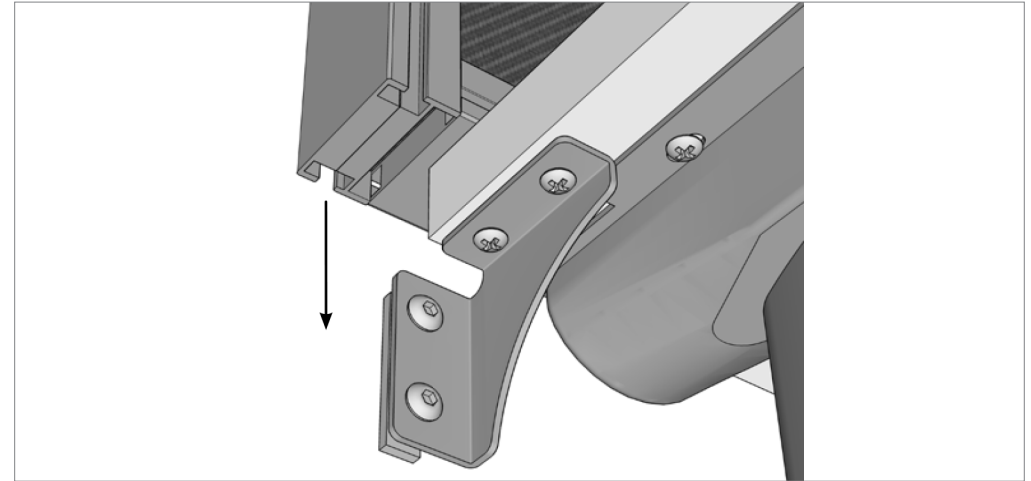

**STEP 2:** With brackets in place, lift screen above the desk, and slide Studio50 panel onto brackets.

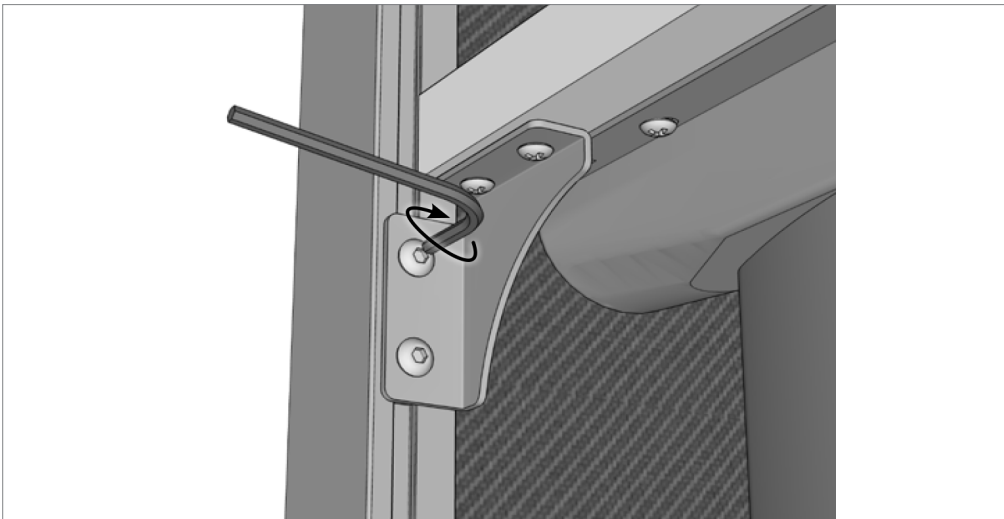

**STEP 3:** With screen in place, fully bracket screws to the screen, then fully tighten screws into desktop.

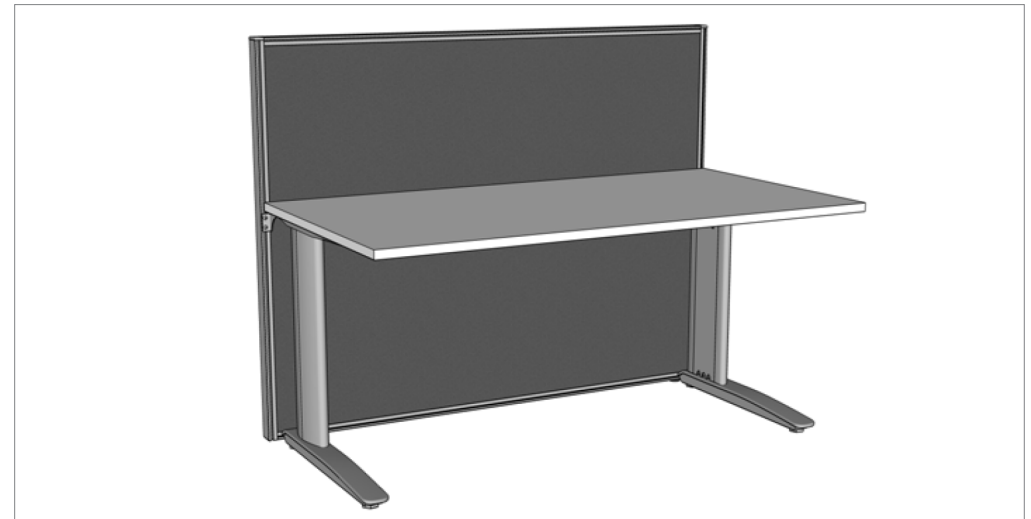

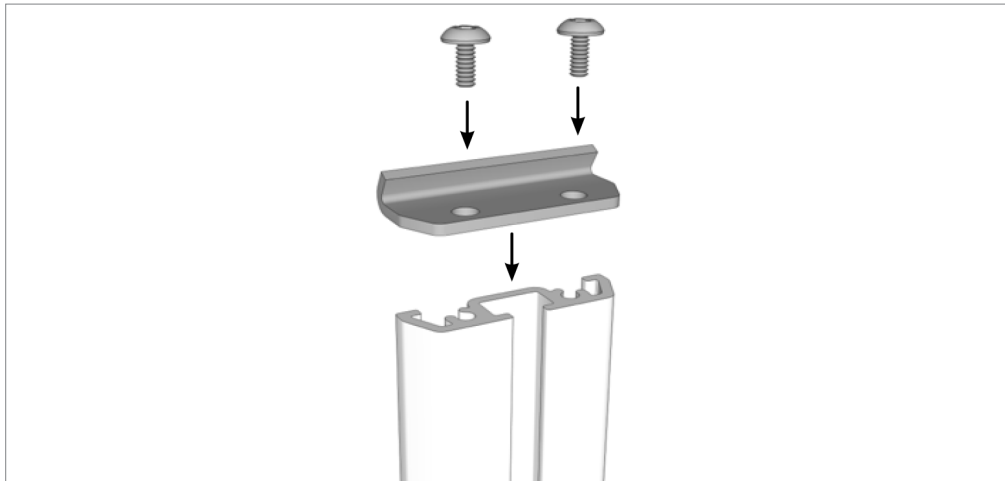

**STEP 1:** Fix top hook (STU50ACS/Z) to shelf extrusion.

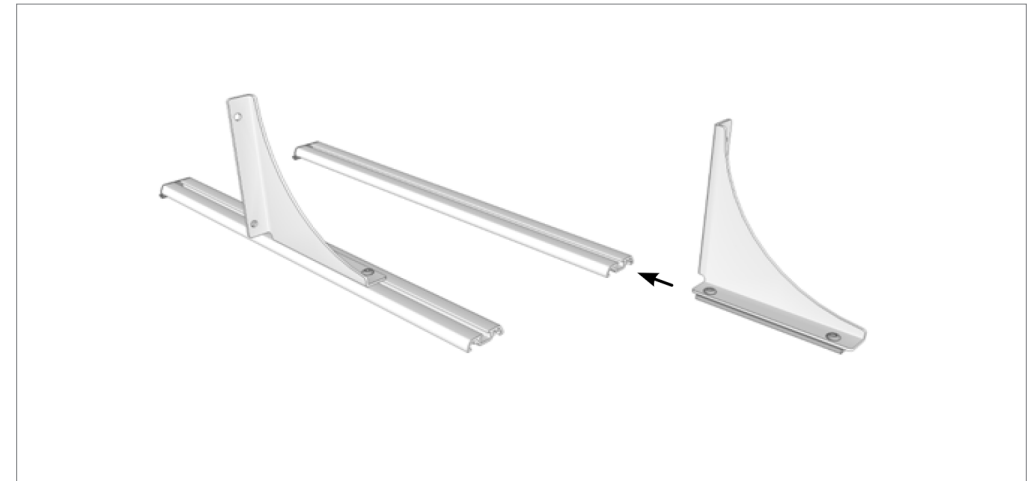

**STEP 2:** Slide 150mm brackets into shelf extrusion, and tighten screws with both brackets in the same location.

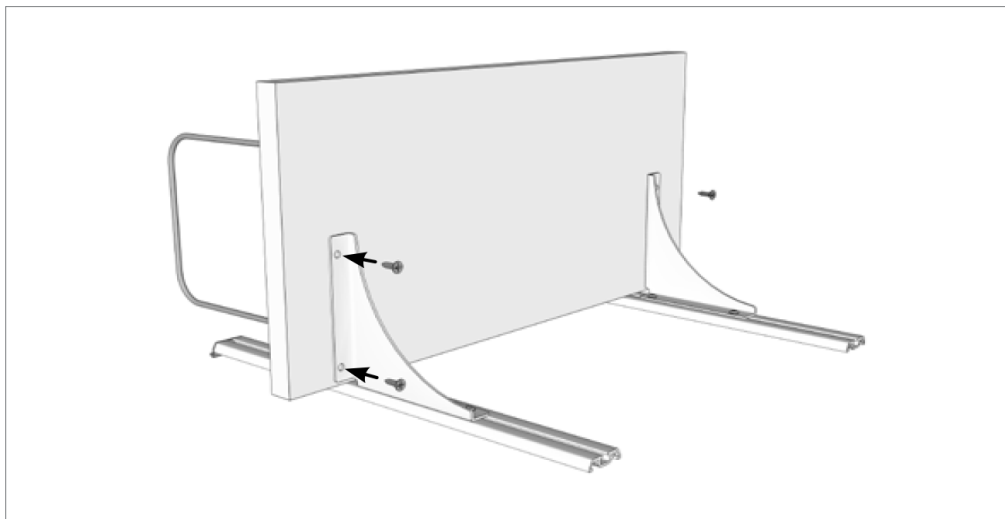

**STEP 3:** Fully tighten screws through 150mm brackets into shelf.

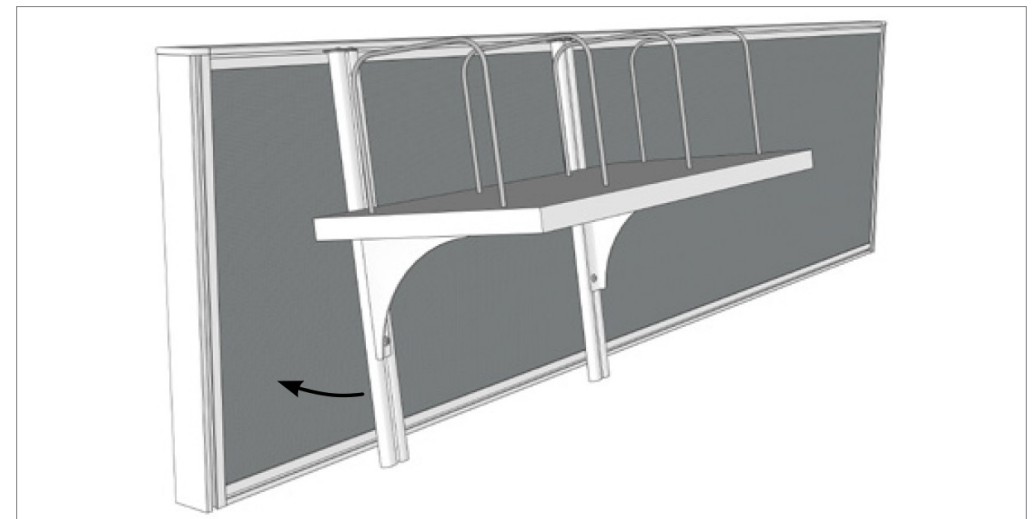

**STEP 4:** Clip top hooks into screen.

# Studio50 for Straightline Desking

## Assembly Instructions

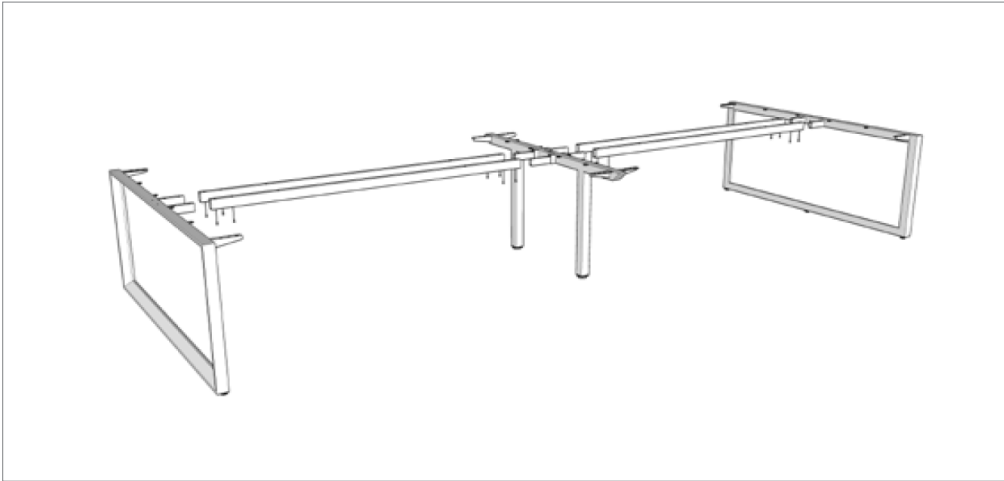

**STEP 1:** Assemble frames & rails together, loosely (1 turn from tight).

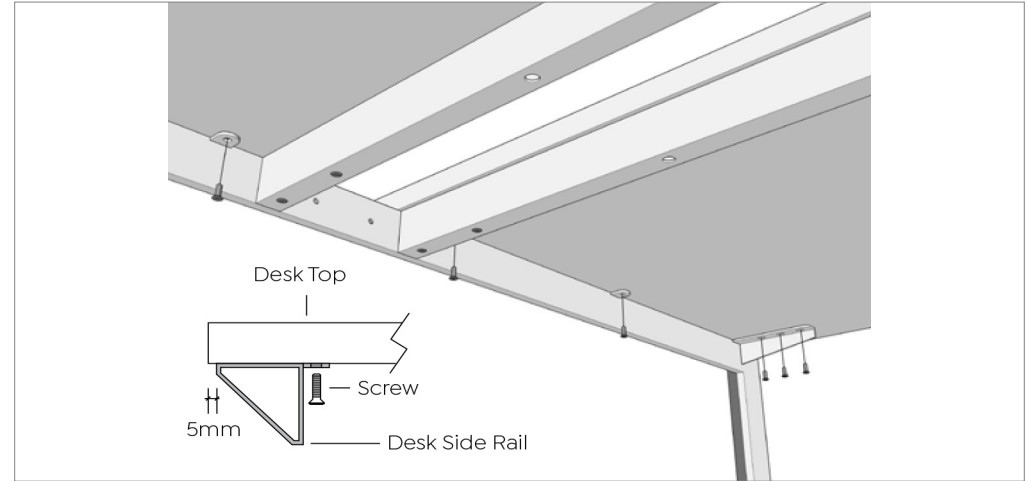

**STEP 2:** Fix desk top to frame with 5mm overhang over metal frame. Where desktops butt together, make sure these are fitted tight together.

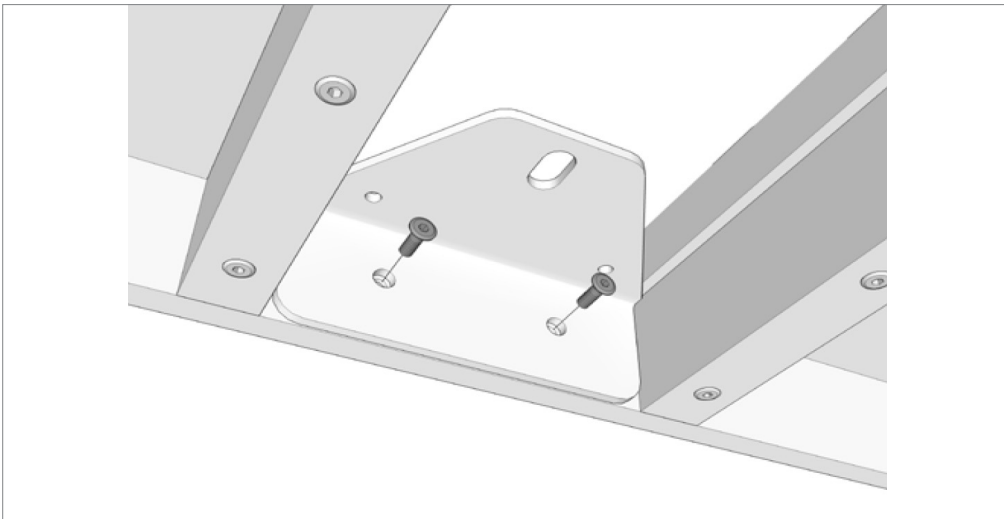

**STEP 3:** Assemble screen brackets firmly to frames (inside of end leg frame).

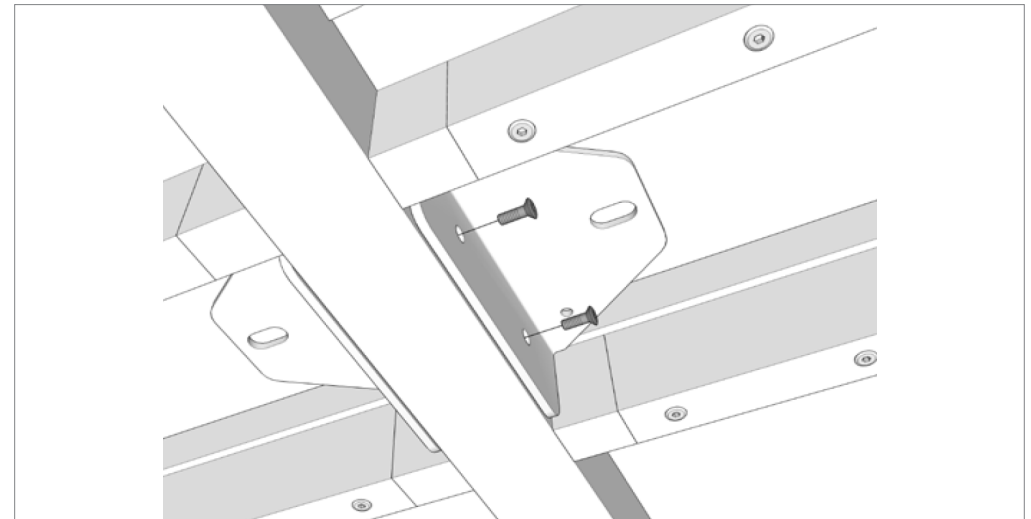

**STEP 4:** Firmly assemble screen brackets to frames, ensuring the top of the screen bracket is flush/level with the top of the frame (middle leg).

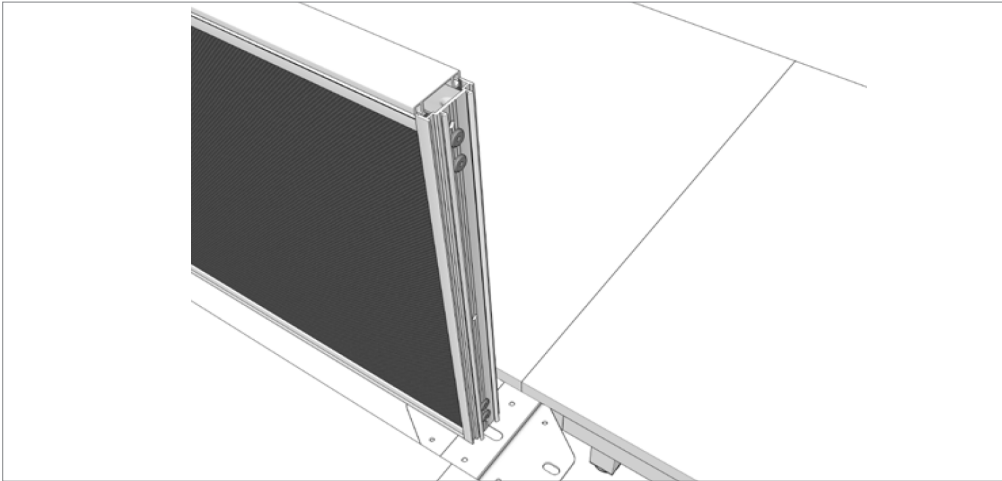

**STEP 5:** Place the first screen on desk frame/screen brackets, with the end of the screen overhanging the work top by 5mm.

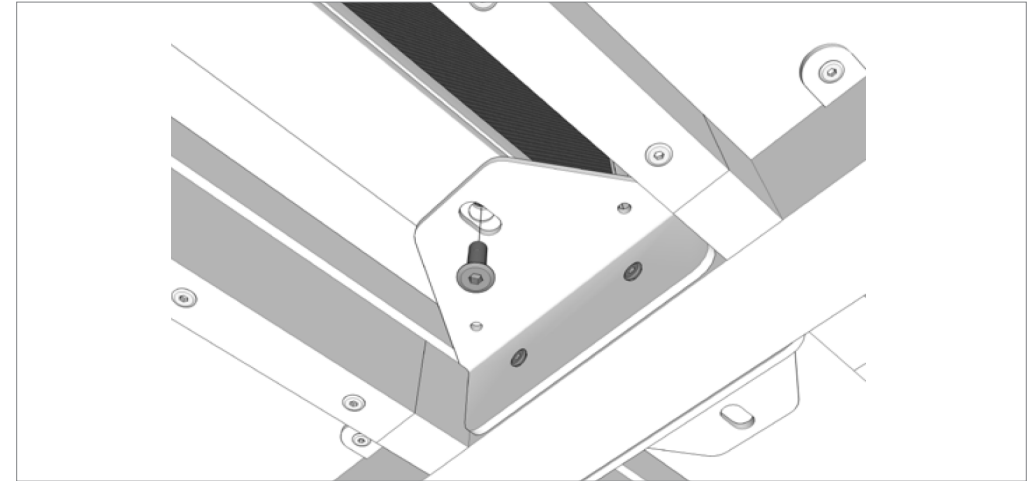

**STEP 6:** Firmly screw large bolts through brackets into the base of screen.

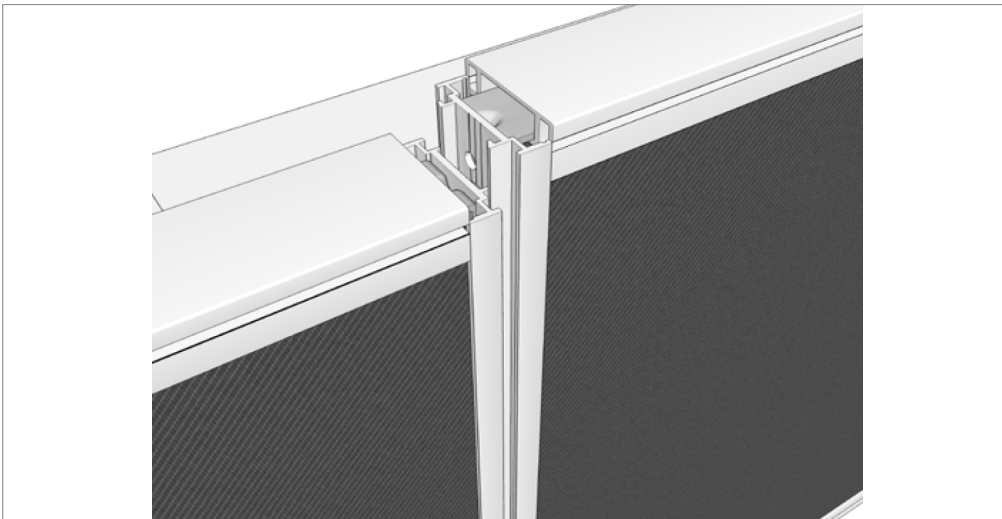

**STEP 7:** Slide the second screen down onto first using the auto lock system to fix the second screen, and screw the large bolts underneath to lock screens in place.

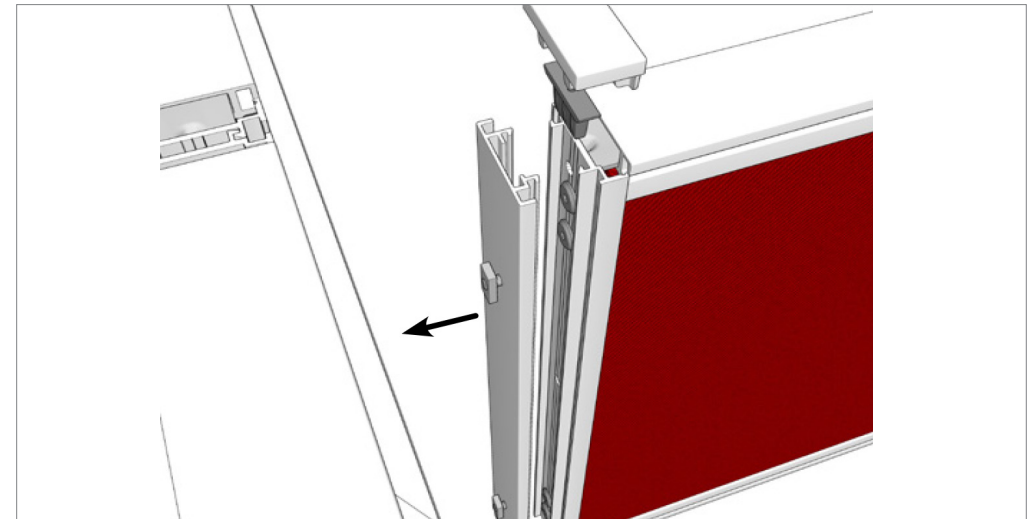

**STEP 8:** Remove the top cap and locking slug from the end of the wing screens that contain the small grub screws. Take the end panel off the screen

# Studio50 for Straightline Desking

## Assembly Instructions

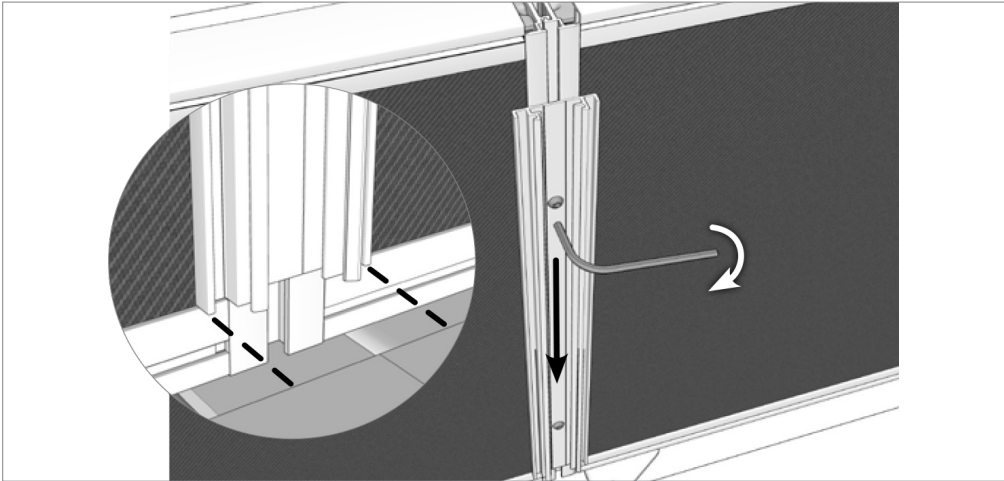

**STEP 9:** Slide this wing screen end panels down the join between the centre screens. Line the bottom of this panel with the top of the work surface, and firmly tighten in place.

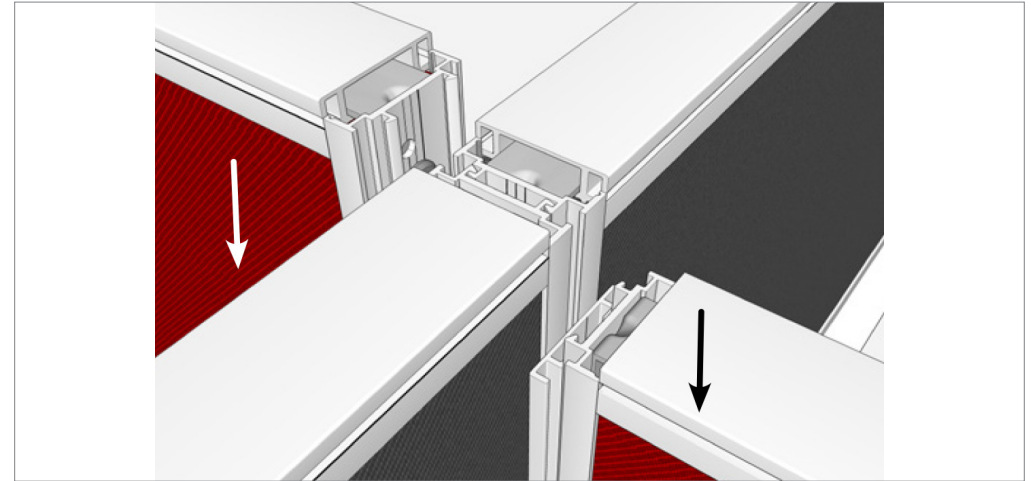

**STEP 10:** Slide the wing screens onto the end panels.

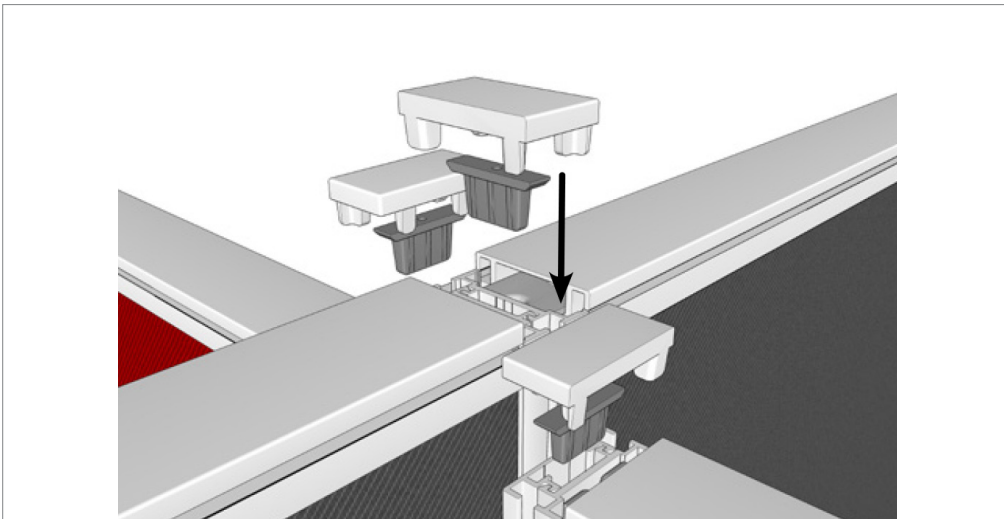

**STEP 11:** Install all locking slugs, and end caps, gently tapping with a soft non-marking mallet if required.

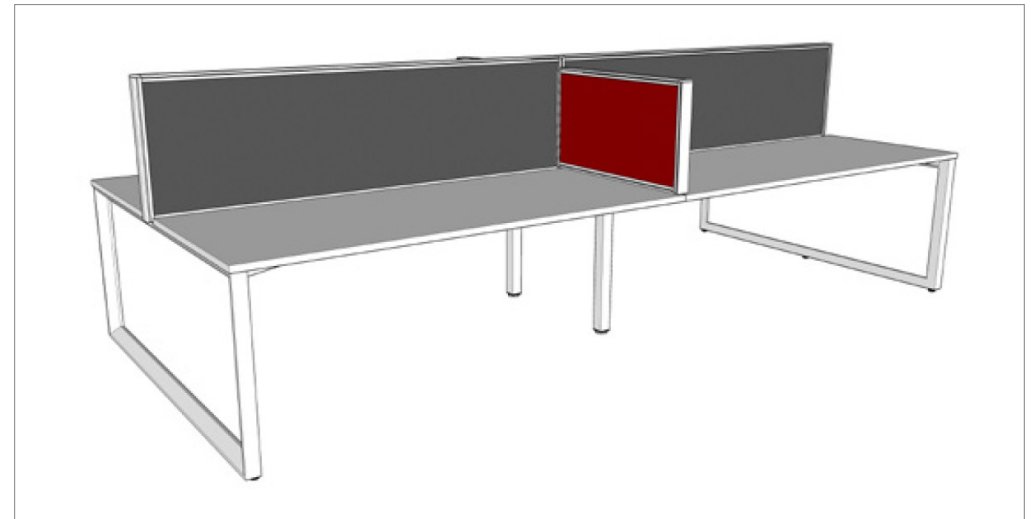



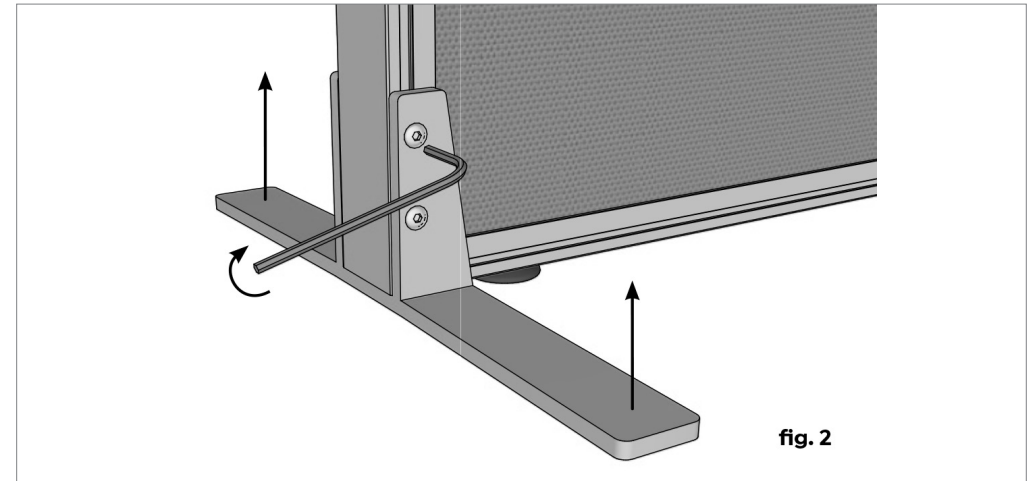
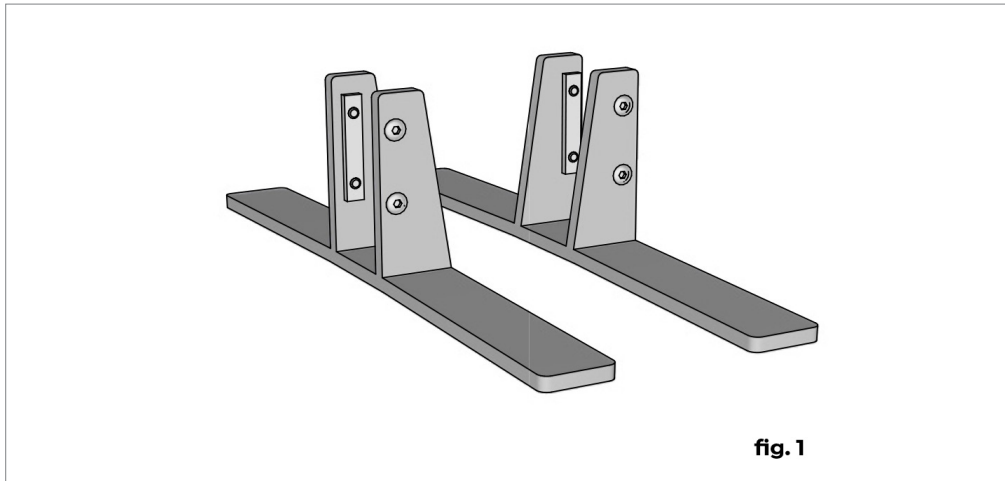

**STEP 1:** Lift screen and slide freestanding foot **fig 1** up on to screen from the bottom, as shown in **fig 2**.

**STEP 2:** Fully tighten bracket screws.





**Sydney** 02 8188 2732  
**Melbourne** 03 9111 0315  
**Brisbane** 07 3733 1923  
**Adelaide** 08 7111 0810  
**Perth** 08 9468 2707

[info@olgoffice.com](mailto:info@olgoffice.com)

[myolg.online](https://myolg.online) | [olgoffice.com](https://olgoffice.com) | [officedesigner.net](https://officedesigner.net) | [motionoffice.com](https://motionoffice.com)